

DSC-H2

SERVICE MANUAL

LEVEL 2

Ver. 1.1 2006.06

Revision History

How to use
Acrobat Reader

Internal memory
ON BOARD



*US Model
Canadian Model
AEP Model
UK Model
E Model
Australian Model
Chinese Model
Argentina Model
Hong Kong Model
Korea Model
Tourist Model*

Link

SPECIFICATIONS	BLOCK DIAGRAMS	PRINTED WIRING BOARDS
SERVICE NOTE	FRAME SCHEMATIC DIAGRAMS	REPAIR PARTS LIST
DISASSEMBLY	SCHEMATIC DIAGRAMS	

- [Precaution on Replacing the SY-150 board](#)

Note :

The components identified by mark \triangle or dotted line with mark \triangle are critical for safety. Replace only with part number specified.

Note :

Les composants identifiés par une marque \triangle sont critiques pour la sécurité. Ne les remplacer que par une pièce portant le numéro spécifié.

DIGITAL STILL CAMERA

SONY[®]

These specifications are extracted from instruction manual of DSC-H2 (2-673-166-11).



SPECIFICATIONS

Camera

[System]

Image device	7.18 mm (1/2.5 type) color CCD, Primary color filter
Total pixel number of camera	Approx. 6 183 000 pixels
Effective pixel number of camera	Approx. 6 003 000 pixels
Lens	Carl Zeiss Vario-Tessar 12× zoom lens f = 6.0 – 72.0 mm (36 – 432 mm when converted to a 35 mm still camera) F2.8 – 3.7
Exposure control	Automatic exposure, Shutter speed priority, Aperture priority, Manual exposure, Scene Selection (7 modes)
White balance	Automatic, Daylight, Cloudy, Fluorescent, Incandescent, Flash, One push
File format (DCF compliant)	Still images: Exif Ver. 2.21 JPEG compliant, DPOF compatible Movies: MPEG1 compliant (Monaural)
Recording media	Internal Memory (30 MB) “Memory Stick Duo”
Flash	Recommended distance (ISO set to Auto): approx. 0.3 m to 9.0 m (11 7/8 inches to 29 feet 6 3/8 inches) (W)/approx. 0.9 m to 6.8 m (35 1/2 inches to 22 feet 3 3/4 inches) (T)
Viewfinder	Electric viewfinder (color)

[Input and Output connectors]

A/V OUT jack (Monaural)	Minijack Video: 1 Vp-p, 75 Ω, unbalanced, sync negative Audio: 327 mV (at a 47 kΩ load) Output impedance 2.2 kΩ
USB jack	mini-B
USB communication	Hi-Speed USB (USB 2.0 compliant)

[LCD screen]

LCD panel	5.1 cm (2.0 type) TFT drive
Total number of dots	84 960 (35424 0) dots

[Finder]

Panel	0.5 cm (0.2 type) color
Total number of dots	Approx. 200 000 dots equivalent

[Power, general]

Power	HR 15/51:HR6 (size AA) Nickel-Metal Hydride batteries (2), 2.4 V R6 (size AA) alkaline batteries (2), 3 V ZR6 (size AA) Oxy Nickel Primary Battery (2), 3 V AC-LS5K AC Adaptor 4.2 V
Power consumption (during shooting with the LCD screen)	1.1 W
Operating temperature	0 to 40°C (32 to 104°F)
Storage temperature	–20 to +60°C (–4 to +140°F)
Dimensions	113.28 3,094.0 mm (4 1/2 inches×3 3/8 inches×3 3/4 inches) (W/H/D, excluding protrusions)
Mass	Approx. 537 g (1 lb 2.9 oz) (including two batteries, shoulder strap, adaptor ring, lens hood, lens cap, etc.)
Microphone	Electret condenser microphone
Speaker	Dynamic speaker
Exif Print	Compatible
PRINT Image Matching III	Compatible
PictBridge	Compatible

BC-CS2A/CS2B Ni-MH battery charger

Power requirements	AC 100 to 240 V, 50/60 Hz, 3 W
Output voltage	AA: DC 1.4V 400 mA × 2 AAA: DC 1.4 V 160 mA × 2
Operating temperature	0 to +40°C (+32 to +104°F)
Storage temperature	–20 to +60°C (–4 to +140°F)
Dimensions	Approx. 713091 mm (2 7/8×1 3/16×3 5/8 inches) (W/H/D)
Mass	Approx. 90 g (3 oz)

Design and specifications are subject to change without notice.

SAFETY CHECK-OUT

After correcting the original service problem, perform the following safety checks before releasing the set to the customer.

1. Check the area of your repair for unsoldered or poorly-soldered connections. Check the entire board surface for solder splashes and bridges.
2. Check the interboard wiring to ensure that no wires are "pinched" or contact high-wattage resistors.
3. Look for unauthorized replacement parts, particularly transistors, that were installed during a previous repair. Point them out to the customer and recommend their replacement.
4. Look for parts which, through functioning, show obvious signs of deterioration. Point them out to the customer and recommend their replacement.
5. Check the B+ voltage to see it is at the values specified.
6. Flexible Circuit Board Repairing
 - Keep the temperature of the soldering iron around 270°C during repairing.
 - Do not touch the soldering iron on the same conductor of the circuit board (within 3 times).
 - Be careful not to apply force on the conductor when soldering or unsoldering.

SAFETY-RELATED COMPONENT WARNING!!

COMPONENTS IDENTIFIED BY MARK \triangle OR DOTTED LINE WITH MARK \triangle ON THE SCHEMATIC DIAGRAMS AND IN THE PARTS LIST ARE CRITICAL TO SAFE OPERATION. REPLACE THESE COMPONENTS WITH SONY PARTS WHOSE PART NUMBERS APPEAR AS SHOWN IN THIS MANUAL OR IN SUPPLEMENTS PUBLISHED BY SONY.

CAUTION :

Danger of explosion if battery is incorrectly replaced.
Replace only with the same or equivalent type.

Unleaded solder

Boards requiring use of unleaded solder are printed with the lead-free mark (LF) indicating the solder contains no lead. (Caution: Some printed circuit boards may not come printed with the lead free mark due to their particular size.)



: LEAD FREE MARK

Unleaded solder has the following characteristics.

- Unleaded solder melts at a temperature about 40°C higher than ordinary solder.
Ordinary soldering irons can be used but the iron tip has to be applied to the solder joint for a slightly longer time.
Soldering irons using a temperature regulator should be set to about 350°C.
Caution: The printed pattern (copper foil) may peel away if the heated tip is applied for too long, so be careful!
- Strong viscosity
Unleaded solder is more viscous (sticky, less prone to flow) than ordinary solder so use caution not to let solder bridges occur such as on IC pins, etc.
- Usable with ordinary solder
It is best to use only unleaded solder but unleaded solder may also be added to ordinary solder.

ATTENTION AU COMPOSANT AYANT RAPPORT À LA SÉCURITÉ!

LES COMPOSANTS IDENTIFIÉS PAR UNE MARQUE \triangle SUR LES DIAGRAMMES SCHÉMATIQUES ET LA LISTE DES PIÈCES SONT CRITIQUES POUR LA SÉCURITÉ DE FONCTIONNEMENT. NE REMPLACER CES COMPOSANTS QUE PAR DES PIÈCES SONY DONT LES NUMÉROS SONT DONNÉS DANS CE MANUEL OU DANS LES SUPPLÉMENTS PUBLIÉS PAR SONY.

TABLE OF CONTENTS

1. SERVICE NOTE

- 1-1. DESCRIPTION ON SELF-DIAGNOSIS DISPLAY 1-1
- 1-2. METHOD FOR COPYING OR ERASING THE DATA IN INTERNAL MEMORY 1-2
- 1-3. PRECAUTION ON REPLACING THE SY-150 BOARD 1-3
- 1-4. VIDEO OUT DEFAULT DATA CHECK 1-3
- 1-5. INITIAL LANGUAGE DATA CHECK 1-3

2. DISASSEMBLY

- 2-1. DISASSEMBLY 2-3

3. BLOCK DIAGRAMS

- 3-1. OVERALL BLOCK DIAGRAM 3-1
- 3-2. POWER BLOCK DIAGRAM 3-5

4. PRINTED WIRING BOARDS AND SCHEMATIC DIAGRAMS

- 4-1. FRAME SCHEMATIC DIAGRAM 4-1
- 4-2. SCHEMATIC DIAGRAMS 4-5
- 4-3. PRINTED WIRING BOARDS 4-43
- 4-4. MOUNTED PARTS LOCATION 4-56

5. REPAIR PARTS LIST

- 5-1. EXPLODED VIEWS 5-3
- 5-2. ELECTRICAL PARTS LIST 5-10

1. SERVICE NOTE

1-1. DESCRIPTION ON SELF-DIAGNOSIS DISPLAY

Self-diagnosis display

The camera has a self-diagnosis display. This function displays the camera condition with five-digits (a combination of a letter and figures) on the LCD screen. If this occurs check the following code chart. The five-digits display informs you of the camera's current condition. The last two digits (indicated by □□) will differ depending on the state of the camera.

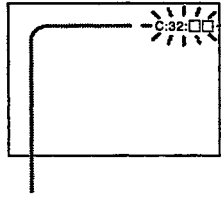

Self-diagnosis display

- C: □□: □□
The contents which can be handled by customer, are displayed.
- E: □□: □□
The contents which can be handled by engineer, are displayed.

Display Code	Countermeasure	Cause	Caution Display During Error
C:32:01	Turn off the main power then back on.	Trouble with hardware.	SYSTEM ERROR
C:13:01	Replace the memory stick. Format the memory stick with the DSC-H2.	<ul style="list-style-type: none"> • The type of memory stick that cannot be used by this machine, is inserted. • Data is damaged. • Unformatted memory stick is inserted. 	MS ERROR
E:91:01	Checking of flash unit or replacement of flash unit.	Abnormality when flash is being charged.	Flash LED Flash display Flashing at 3.2 Hz
E:61:00 *1	Checking of lens drive circuit	When failed in the focus initialization.	—
E:61:10 *1			
E:62:10 *1	Inspect angular velocity sensor peripheral circuits.	Steady shot function does not work well.	—
E:62:11 *1			

Note : The error code is cleared if the battery is removed, except defective flash unit.

*1: The error display is given in two ways.

1-2. METHOD FOR COPYING OR ERASING THE DATA IN INTERNAL MEMORY

The data can be copied/erased by the operations on the Setup screen. (When erasing the data, execute formatting the internal memory.)

Note: 1 When replacing the SY-150 board, erase the data in internal memory of the board before replacement.

Note: 2 When replacing the SY-150 board or the IC202 on the SY-150 board, execute formatting and initialize the internal memory after replacement.

Method for Copying the Data in Internal Memory

Copy

Copies all images in the internal memory to a "Memory Stick".

<input type="checkbox"/>	OK	See the following procedure.
<input checked="" type="checkbox"/>	Cancel	Cancels the copying.

- ① Insert a "Memory Stick" having 32 MB or larger capacity.
- ② Select [OK] with ▲ on the control button, then press ●.
The message "All data in internal memory will be copied Ready?" appears.
- ③ Select [OK] with ▲, then press ●.
Copying starts.

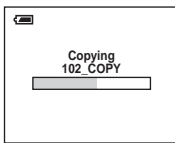

Use batteries with enough capacity or the AC Adaptor (not supplied). If you attempt to copy image files using batteries with little remaining capacity, the batteries may run out, causing copying to fail or possibly corrupting the data.

You cannot copy individual images.

The original images in the internal memory are retained even after copying. To delete the contents of the internal memory, remove the "Memory Stick" after copying, then execute the [Format] command in  Internal Memory Tool.

You cannot select a folder copied on a "Memory Stick".

The setting of  (Print order) marks is not copied even when you copy data.

Method for Formatting the Internal Memory

Format

Formats the internal memory.

Note that formatting irrevocably erases all data in the internal memory, including even protected images.

<input type="checkbox"/>	OK	See the following procedure.
<input checked="" type="checkbox"/>	Cancel	Cancels the formatting.

- ① Select [OK] with ▲ on the control button, then press ●.
The message "All data in internal memory will be erased Ready?" appears.
- ② Select [OK] with ▲, then press ●.
The format is complete.

• PROCESS AFTER FIXING FLASH ERROR

When "FLASH error" (Self-diagnosis Code E : 91 : **) occurs, to prevent any abnormal situation caused by high voltage, setting of the flash is changed automatically to disabling charge and flash setting.

After fixing, this setting needs to be deactivated. Flash error code can be initialized by the operations on the Setup screen.

Method for Initializing the Flash Error Code

Initialize

Initializes the setting to the default setting.

<input type="checkbox"/>	OK	See the following procedure.
<input checked="" type="checkbox"/>	Cancel	Cancels the resetting.

- ① Select [OK] with ▲ on the control button, then press ●.
The message "Initialize all settings Ready?" appears.
- ② Select [OK] with ▲, then press ●.
The settings are reset to the default setting.
Make sure that the power is not disconnected during resetting.

1-3. PRECAUTION ON REPLACING THE SY-150 BOARD

- The Repair Board has already been adjusted. Re-initialization or EVR data copy from the set before repair is not required.
- Perform “VIDEO OUT Default Data Check” and “Initial Language Data Check” mentioned below, and also the adjustment items necessary after SY Board replacement.

1-4. VIDEO OUT DEFAULT DATA CHECK

When you replace to the repairing board, the written data of repairing board also might be changed to original setting because of broadcast system (NTSC/PAL).

When the data has changed because of board replacing etc., check the default data of VIDEO OUT if destination code is right. If not, rewrite to the right value.

VIDEO OUT Default Data

Page	Address	Data	
		NTSC	PAL
4F	8D	00	01

Writing Method:

- 1) Select page: 00, address: 01, and set data: 01.
- 2) Select page: 4F, address: 8D, and set data: 00 (NTSC) or data: 01 (PAL).
- 3) Select page: 40, address: 38, and set data: 00.
- 4) Click **Save** on the SEUS screen.
- 5) Select page: 80, address: 34, and check that the data is “00”.
- 6) Select page: 80, address: 30, and check that the data is “00”.
- 7) Select page: 00, address: 01, and set data: 00.

1-5. INITIAL LANGUAGE DATA CHECK

If the SY-150 board was replaced, initial language setting may be changed. Accordingly, change the following data so as to set same initial language as that of the set distributing in each region.

Initial language: Language displayed at the next starting if the setting of Setup menu was reset.
It is different from the language setting selectable with the menu.

Initial Language Data

Page	Address	Data	Language	GP2	GP3	GP4
4F	8C	00	English	●	●	●
		04	Spanish		●	●
		08	Simplified Chinese			●
		0B	Russian		●	
		0D	Korean			●

Note: GP2 is fixed to English.
GP3 is either English, Spanish, or Russian.
GP4 is either English, Spanish, Simplified Chinese, or Korean.

Writing Method:

- 1) Select page: 00, address: 01, and set data: 01.
- 2) Select page: 4F, address: 8C, and set the Initial Language Data.
- 3) Select page: 40, address: 38, and set data: 00.
- 4) Click **Save** on the SEUS screen.
- 5) Select page: 80, address: 34, and check that the data is “00”.
- 6) Select page: 80, address: 30, and check that the data is “00”.
- 7) Select page: 00, address: 01, and set data: 00.
- 8) Turn off the camera.
- 9) Turn on the camera. Execute “Initialize” of Setup screen.
- 10) Check the language displayed when the camera starts.

2. DISASSEMBLY

Link

- [DISASSEMBLY](#)

- [HELP](#)

- [COMMON NOTE FOR DISASSEMBLY](#)

2. DISASSEMBLY

2. DISASSEMBLY

NOTE FOR REPAIR

Make sure that the flat cable and flexible board are not cracked or bent at the terminal.
Do not insert the cable insufficiently nor crookedly.

When remove a connector, don't pull at wire of connector.
Be in danger of the snapping of a wire.

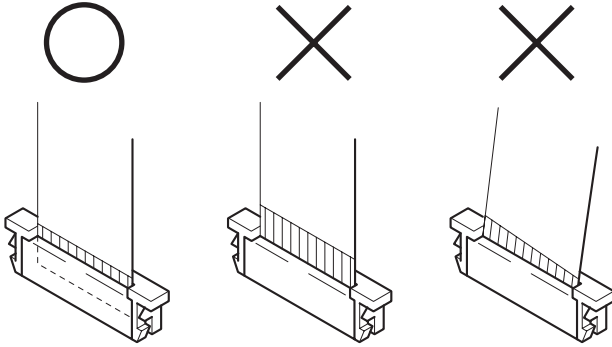

When installing a connector, don't press down at wire of connector.
Be in danger of the snapping of a wire.

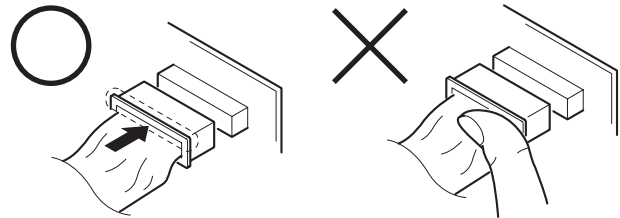

Cut and remove the part of gilt which comes off at the point.
(Take care that there are some pieces of gilt left inside)

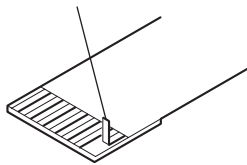

DISCHARGING OF THE FLASHLIGHT POWER SUPPLY CAPACITOR

The charging elect capacitor 320uF (330V) is charged up to the maximum 300 V potential.

There is a danger of electric shock by this high voltage when the capacitor is handled by hand. The electric shock is caused by the charged voltage which is kept without discharging when the main power of the DSC-H2 is simply turned off. Therefore, the remaining voltage must be discharged as described below.

Discharging the Capacitor

Short circuits between the positive and the negative terminals of charged capacitor with the short jig about 10 seconds.

Preparing the Short Jig

To preparing the short jig, a small clip is attached to each end of a resistor of 1 kW /1 W (1-215-869-11)

Wrap insulating tape fully around the leads of the resistor to prevent electrical shock.

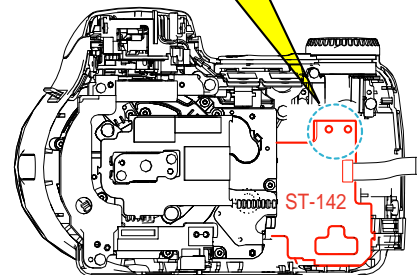
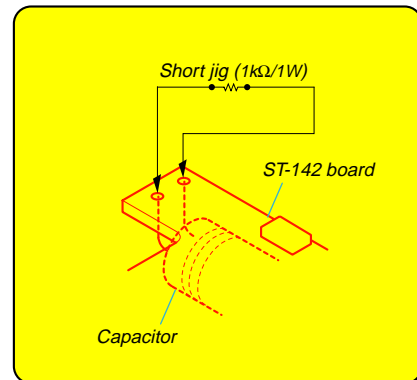
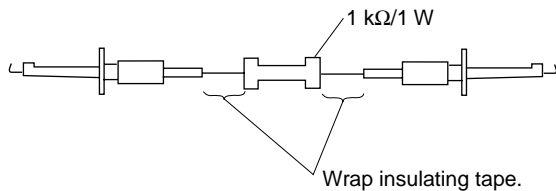

2. DISASSEMBLY

The following flow chart shows the disassembly procedure.

2-1. DISASSEMBLY

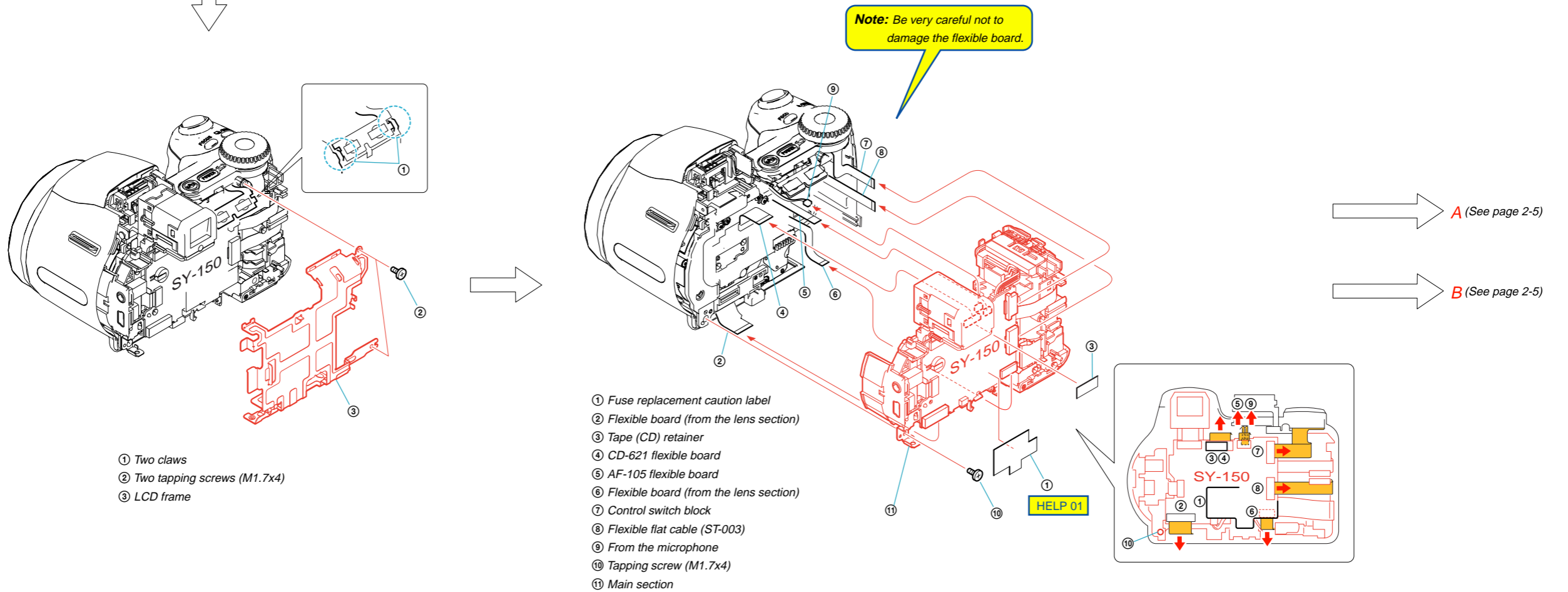
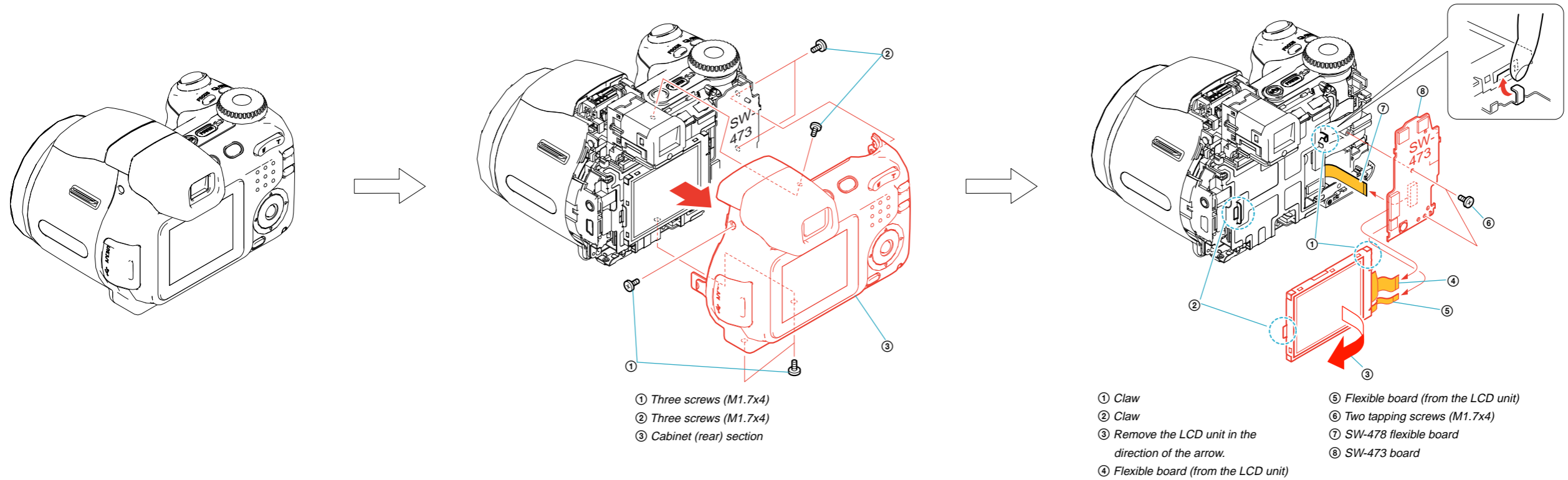

2. DISASSEMBLY

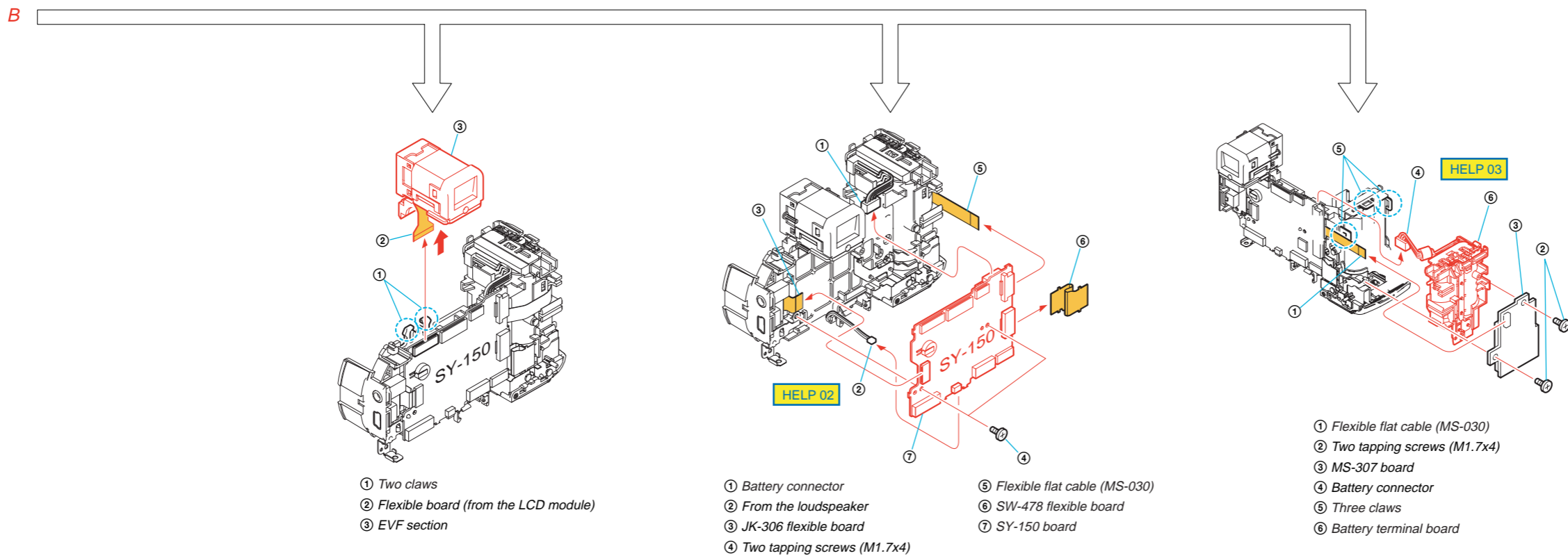
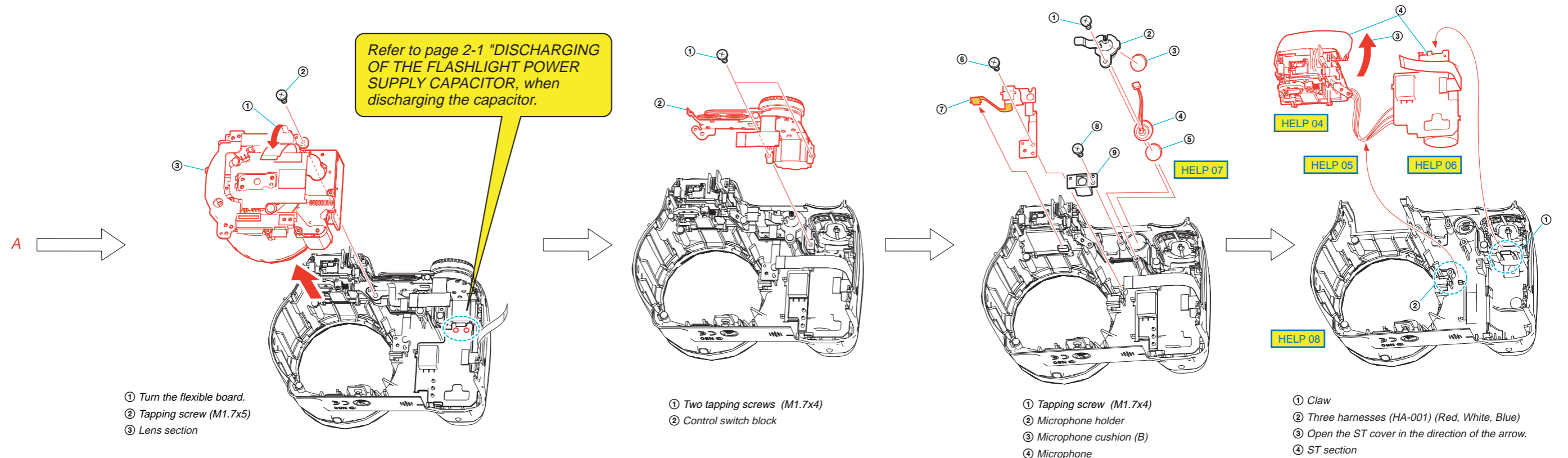

HELP

Disassembling and assembling procedures that require attention are described here.

HELP 01

When attaching the fuse replacement caution label to the SY-150 board, cover the harness of the loudspeaker with the fuse replacement caution label.

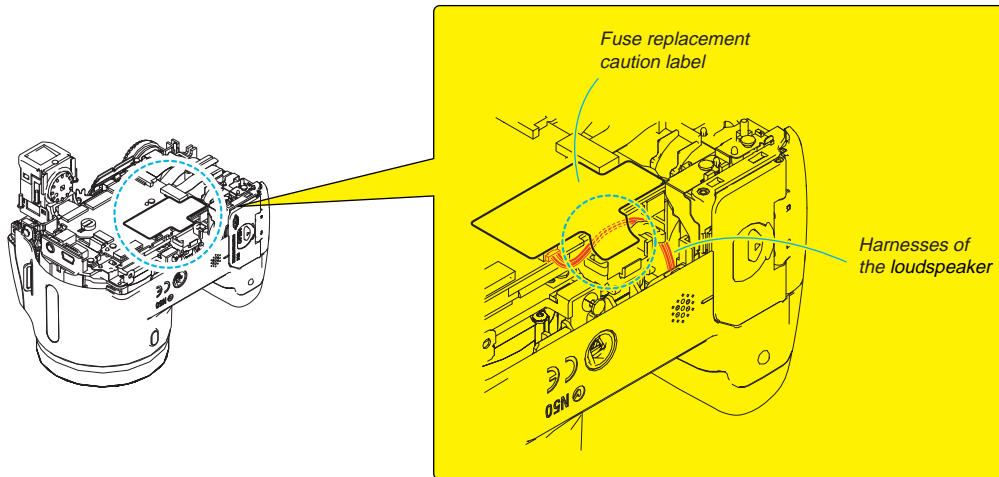

HELP 02

When installing the loudspeaker, route the harnesses of the loudspeaker as shown in the figure.

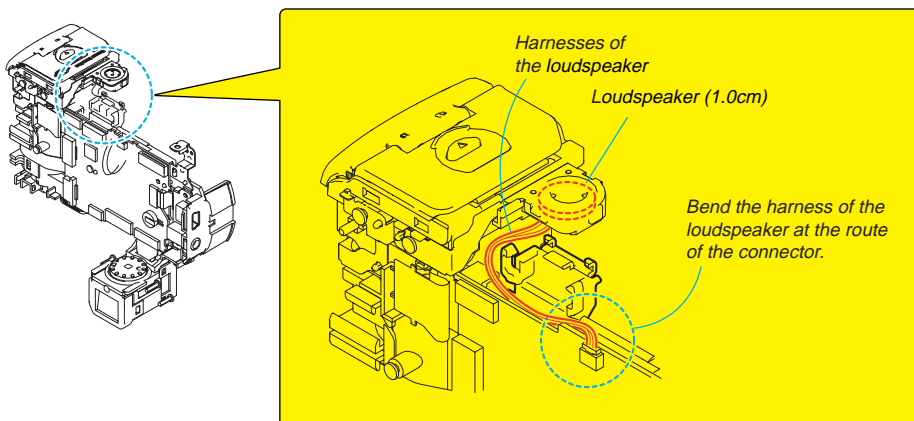

HELP 03

When installing the battery terminal board, route the harnesses of the battery terminal board as shown in the figure.

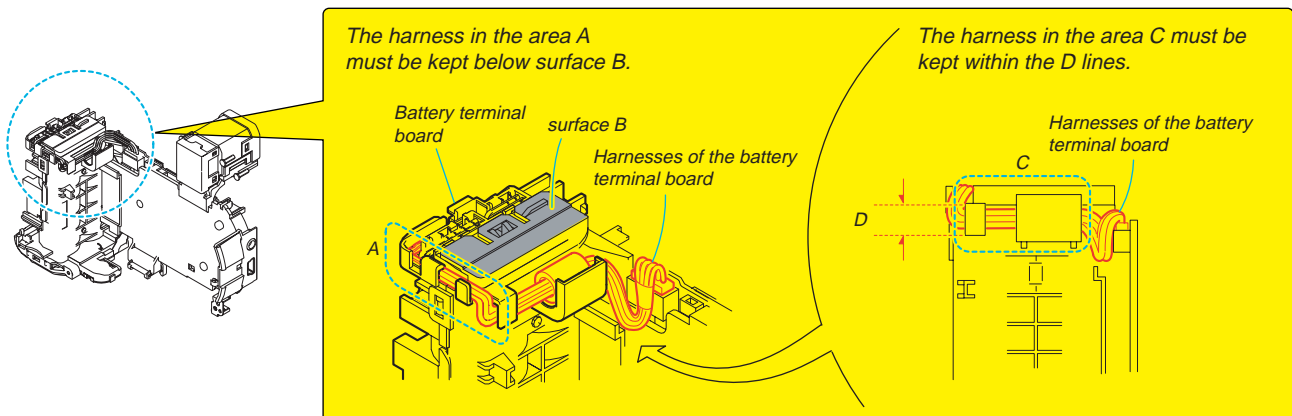

HELP 04

When installing the ST section, route the Harness (HA-004) (Blue), Harness (HA-004)(White), and Harness (HA-004) (Red) as shown in the figure.

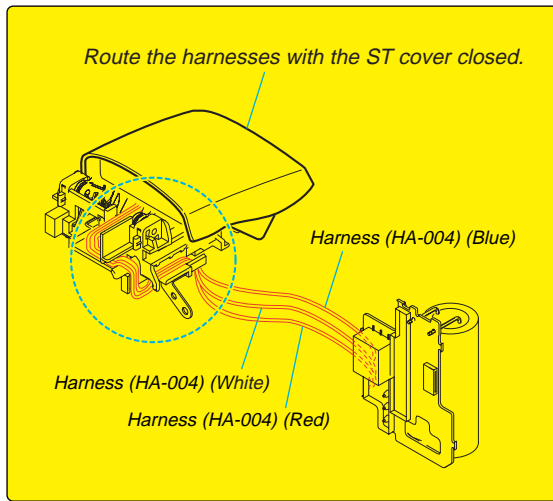

HELP 05

When installing the ST section, route the Harness (HA-004) (Blue), Harness (HA-004)(White), and Harness (HA-004) (Red) as shown in the figure.

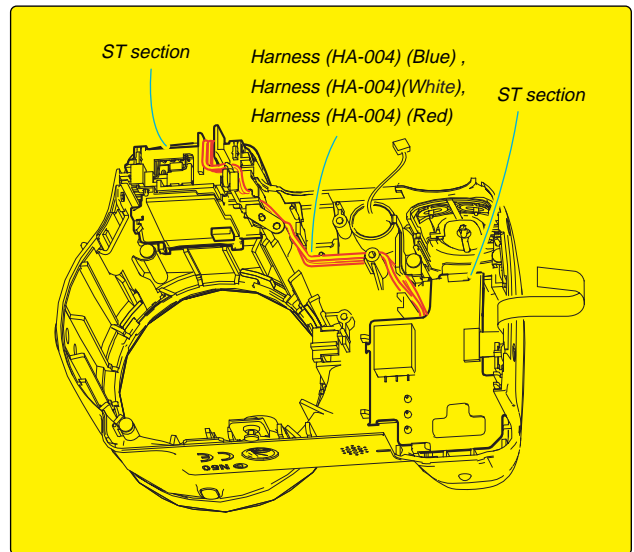

HELP 06

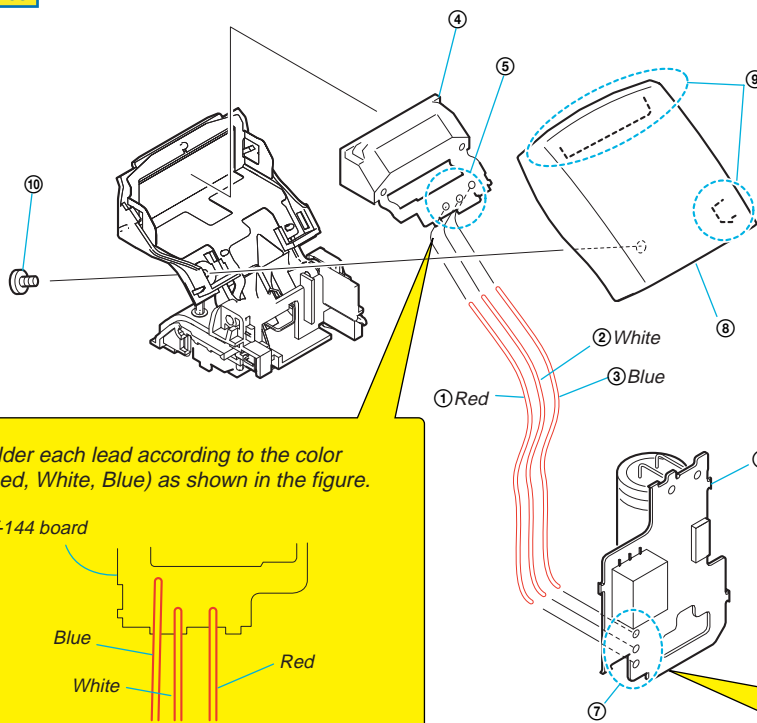

- ① Harness (H-004) (Red)
- ② Harness (H-004) (White)
- ③ Harness (H-004) (Blue)
- ④ Flash unit, ST-144 board
- ⑤ Apply the soldering in three points.
- ⑥ ST-142 board
- ⑦ Apply the soldering in three points.
- ⑧ ST cover
- ⑨ Two claws
- ⑩ Tapping screw (M1.7x4)

Solder each lead according to the color (Red, White, Blue) as shown in the figure.

ST-144 board

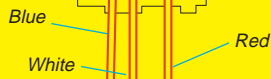

Solder each lead according to the color (Red, White, Blue) as shown in the figure.

ST-142 board

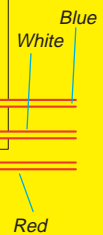

HELP 07

Install the microphone tilted as shown in the figure below.

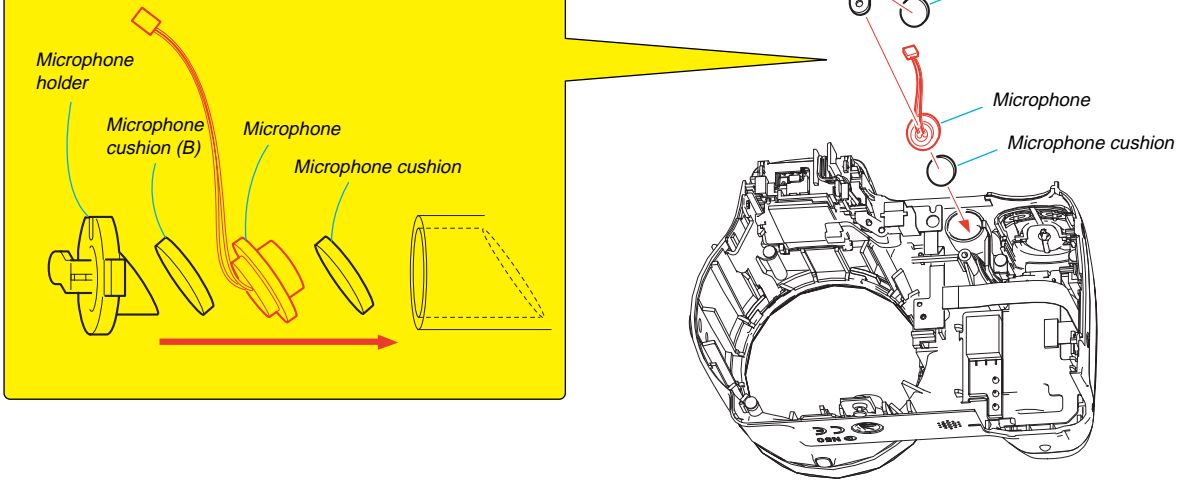

HELP 08

When removing the lens ring, remove the screw and strap sheet metal (R) first. Slide the cap lever in the direction of arrow (A) while taking care that the cap lever is not caught on the notch of the lens ring. Remove the lens ring by turning it in the direction of arrow (B).

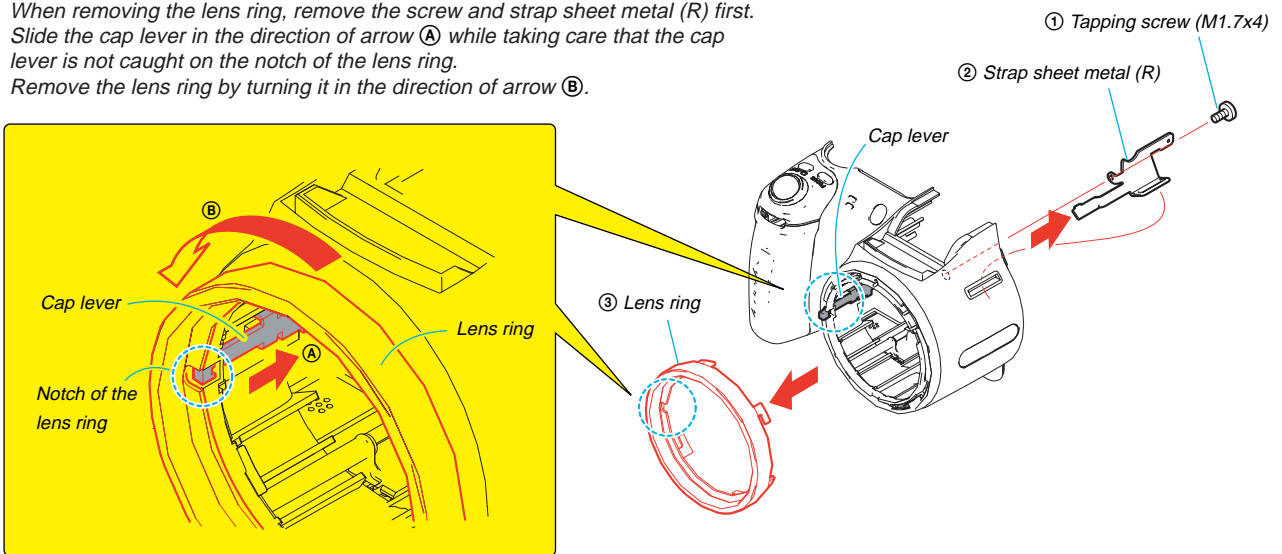

3. BLOCK DIAGRAMS

Link

OVERALL BLOCK DIAGRAM (1/2)	POWER BLOCK DIAGRAM (1/2)
OVERALL BLOCK DIAGRAM (2/2)	POWER BLOCK DIAGRAM (2/2)

3. BLOCK DIAGRAMS

3-1. OVERALL BLOCK DIAGRAM (1/2)

() : Number in parenthesis () indicates the division number of schematic diagram where the component is located.

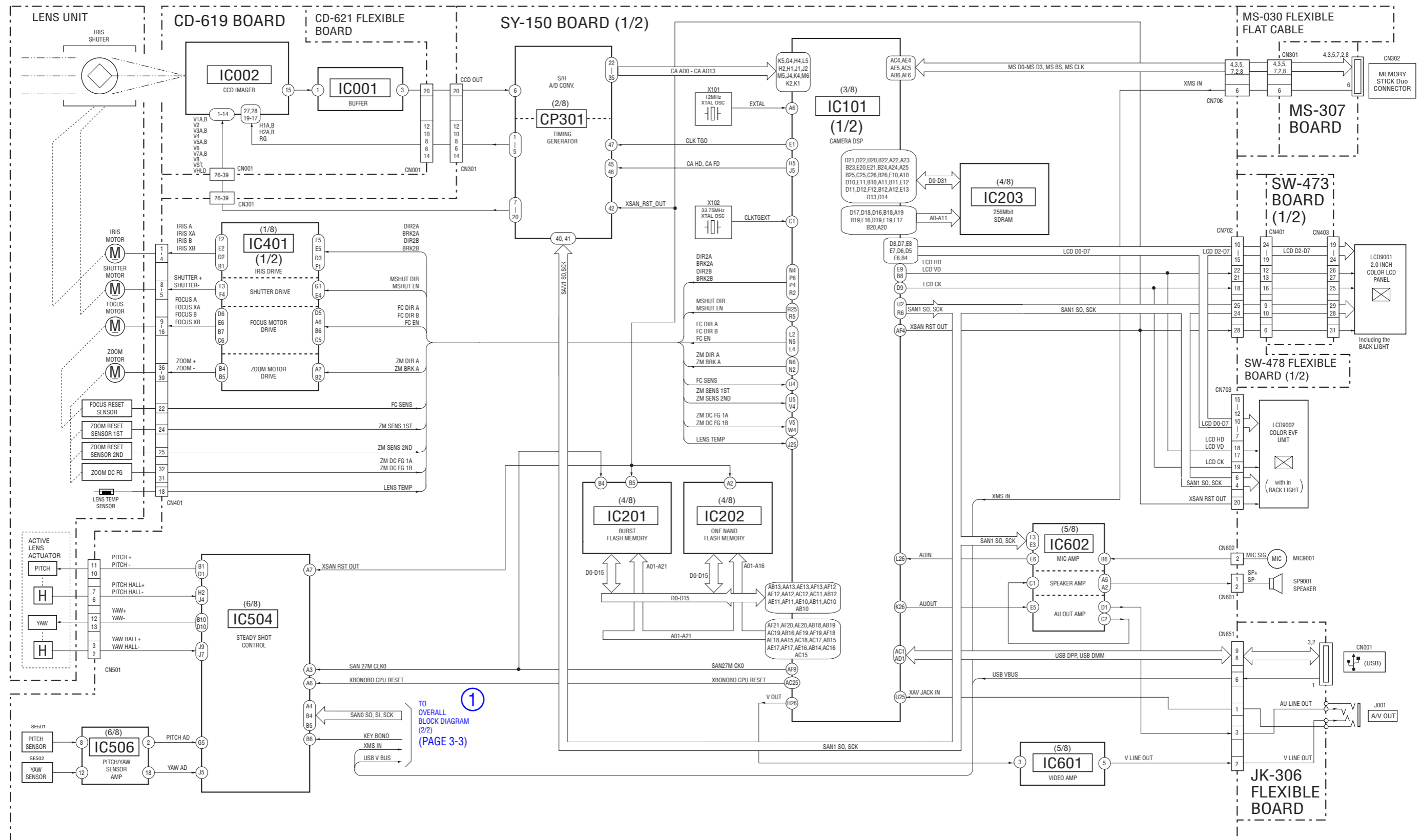

3-2. OVERALL BLOCK DIAGRAM (2/2)

() : Number in parenthesis () indicates the division number of schematic diagram where the component is located.

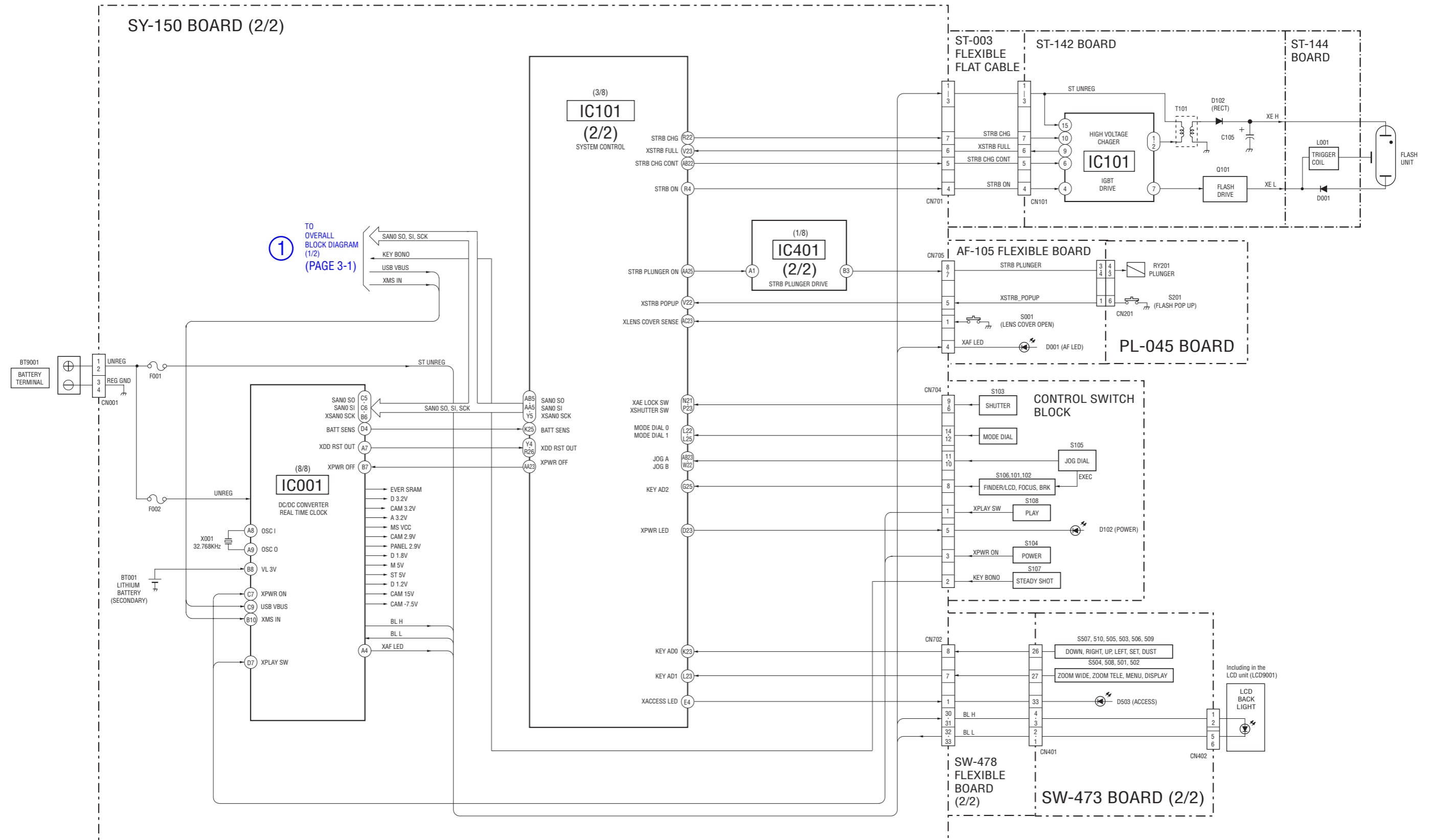

3-3. POWER BLOCK DIAGRAM (1/2)

() : Number in parenthesis () indicates the division number of schematic diagram where the component is located.

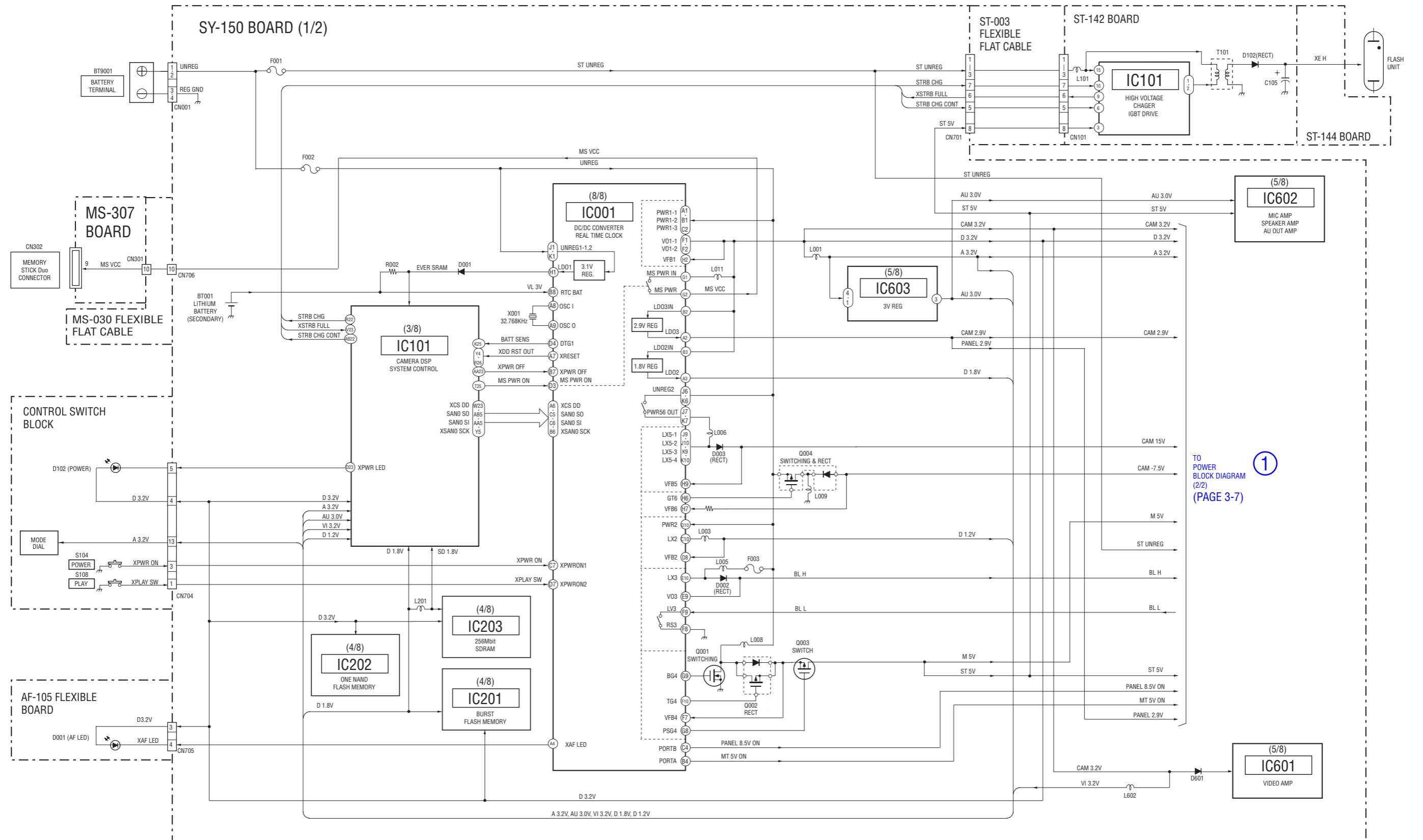

3-4. POWER BLOCK DIAGRAM (2/2)

() : Number in parenthesis () indicates the division number of schematic diagram where the component is located.

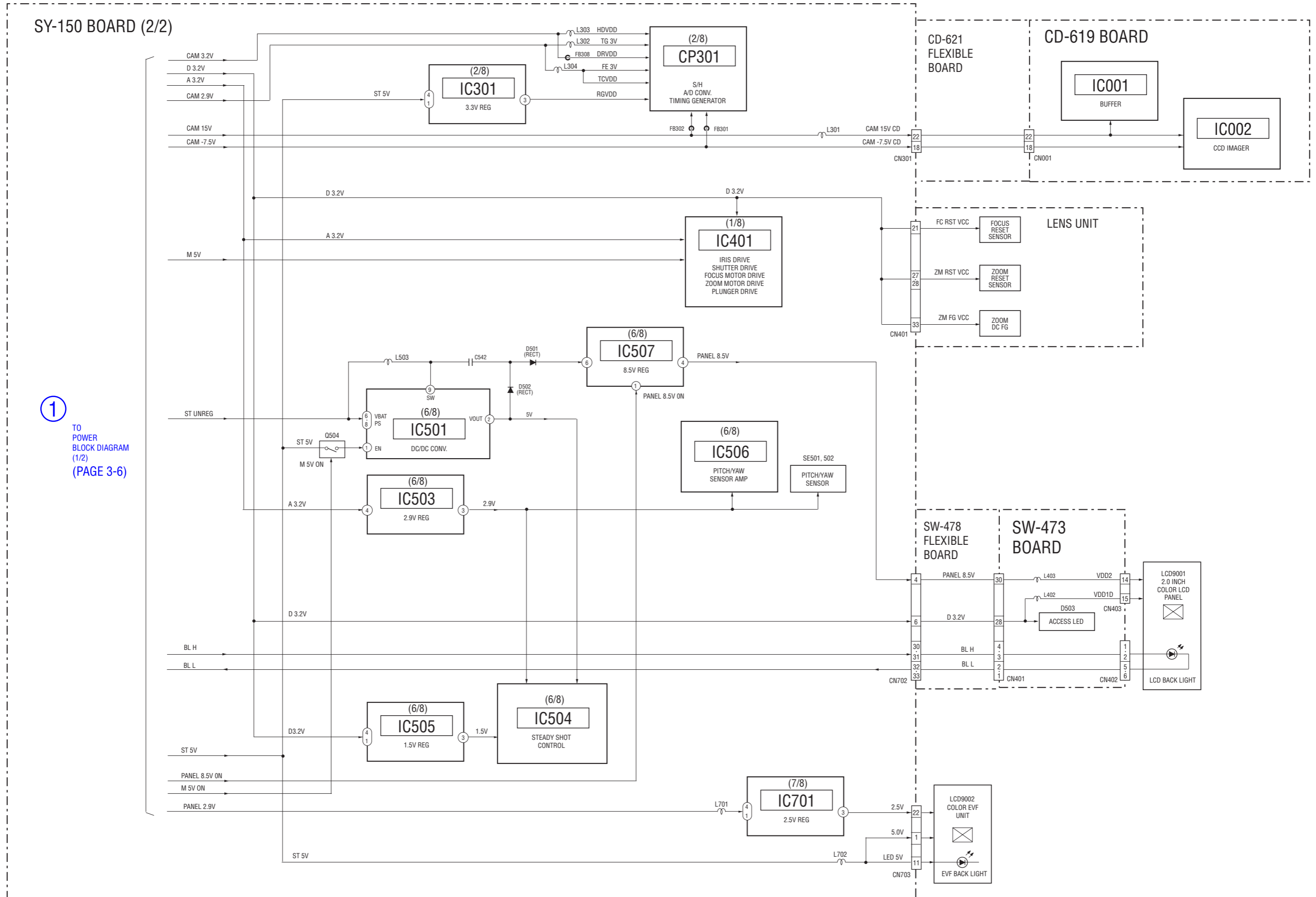

① TO POWER BLOCK DIAGRAM (1/2) (PAGE 3-6)

4. PRINTED WIRING BOARDS AND SCHEMATIC DIAGRAMS

4-1. FRAME SCHEMATIC DIAGRAM

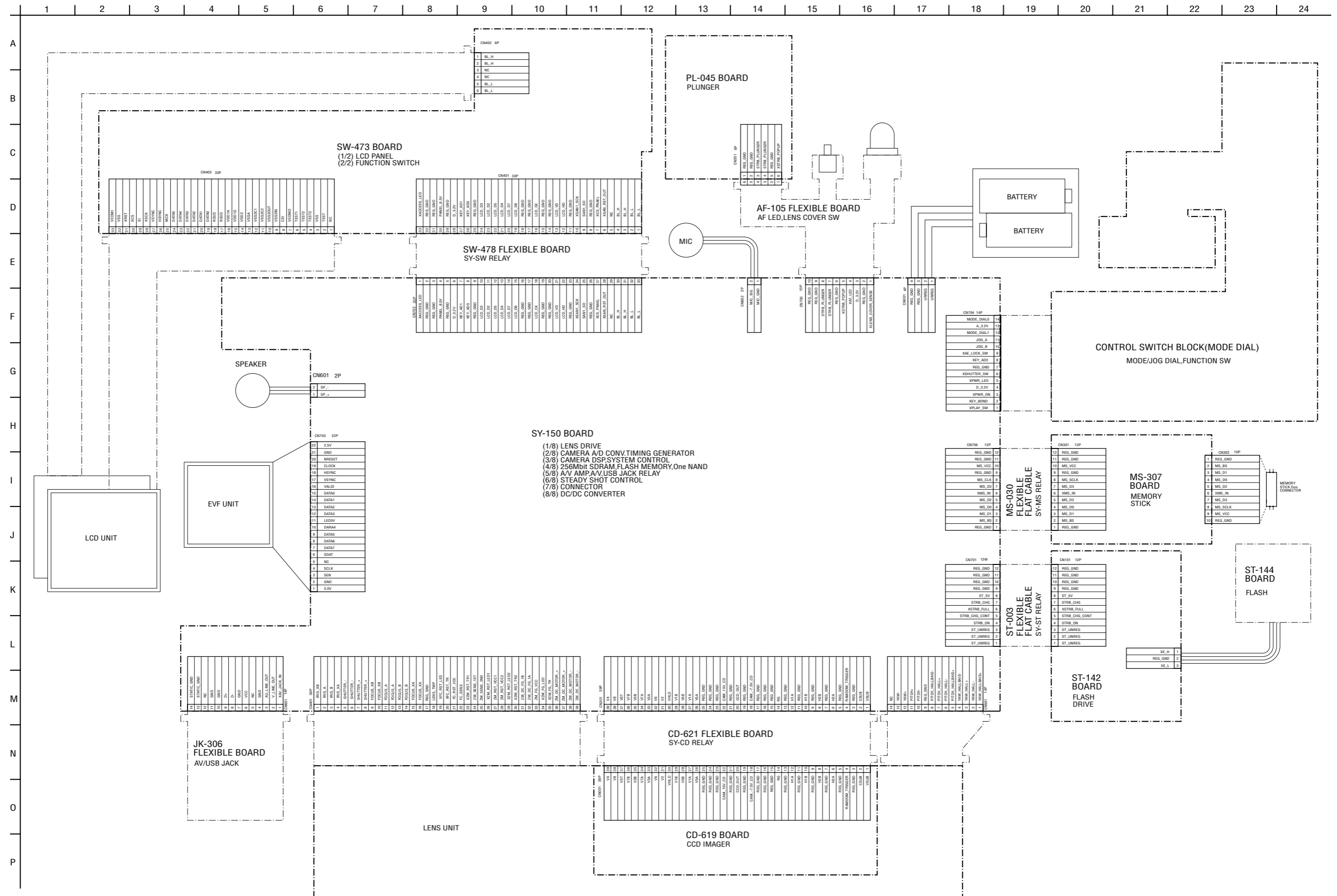

4-2. SCHEMATIC DIAGRAMS

Link

<ul style="list-style-type: none">• CD-619 BOARD (CCD IMAGER)	<ul style="list-style-type: none">• CONTROL SWITCH BLOCK (MODE/JOG DIAL, FUNCTION SW)
<ul style="list-style-type: none">• SW-473 BOARD (1/2) (LCD PANEL)	<ul style="list-style-type: none">• AF-105 FLEXIBLE BOARD (AF LED, LENS COVER SW)
<ul style="list-style-type: none">• SW-473 BOARD (2/2) (FUNCTION SWITCH)	<ul style="list-style-type: none">• JK-306 FLEXIBLE BOARD (AV/USB JACK)
<ul style="list-style-type: none">• ST-142 BOARD (FLASH DRIVE)	<ul style="list-style-type: none">• CD-621 FLEXIBLE BOARD (SY-CD RELAY)
<ul style="list-style-type: none">• ST-144 BOARD (FLASH)	<ul style="list-style-type: none">• SW-478 FLEXIBLE BOARD (SY-SW RELAY)
<ul style="list-style-type: none">• MS-307 BOARD (MEMORY STICK)	<ul style="list-style-type: none">• MS-030 FLEXIBLE FLAT CABLE (SY-MS RELAY)
<ul style="list-style-type: none">• PL-045 BOARD (PLUNGER)	<ul style="list-style-type: none">• ST-003 FLEXIBLE FLAT CABLE (SY-ST RELAY)

- COMMON NOTE FOR SCHEMATIC DIAGRAMS

4-2. SCHEMATIC DIAGRAMS

4-2. SCHEMATIC DIAGRAMS

THIS NOTE IS COMMON FOR SCHEMATIC DIAGRAMS
(In addition to this, the necessary note is printed in each block)

(For schematic diagrams)

- All capacitors are in μF unless otherwise noted. pF : μF . 50 V or less are not indicated except for electrolytics and tantalums.
- Chip resistors are 1/10 W unless otherwise noted. $\text{k}\Omega=1000 \Omega$, $\text{M}\Omega=1000 \text{k}\Omega$.
- Caution when replacing chip parts. New parts must be attached after removal of chip. Be careful not to heat the minus side of tantalum capacitor, Because it is damaged by the heat.
- Some chip part will be indicated as follows.

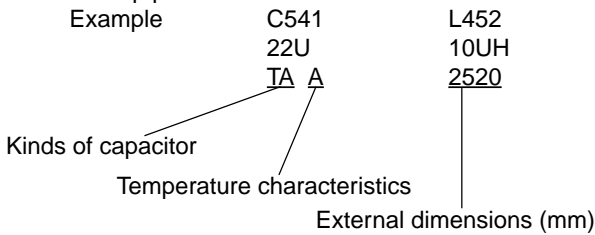

- Constants of resistors, capacitors, ICs and etc with XX indicate that they are not used. In such cases, the unused circuits may be indicated.
- Parts with * differ according to the model/destination. Refer to the mount table for each function.
- All variable and adjustable resistors have characteristic curve B, unless otherwise noted.
- Signal name
XEDIT → EDIT PB/XREC → PB/REC
- : non flammable resistor
- : fusible resistor
- : panel designation
- : B+ Line
- : B- Line
- : IN/OUT direction of (+,-) B LINE.
- : adjustment for repair.

(Measuring conditions voltage)

- Voltages are measured between the measurement points and ground when camera shoots color bar chart of pattern box. They are reference values. (VOM of DC 10 $\text{M}\Omega$ input impedance is used)
- Voltage values change depending upon input impedance of VOM used.)

Precautions for Replacement of imager

- If the imager has been replaced, carry out all the adjustments for the camera section.
- As the imager may be damaged by static electricity from its structure, handle it carefully like for the MOS IC. In addition, ensure that the receiver is not covered with dusts nor exposed to strong light.

1. Connection

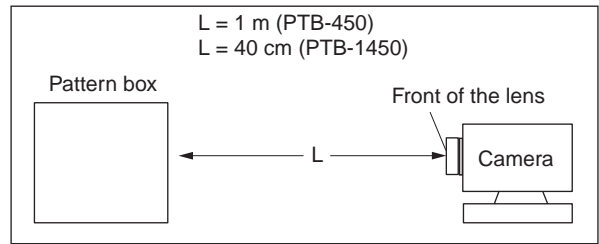
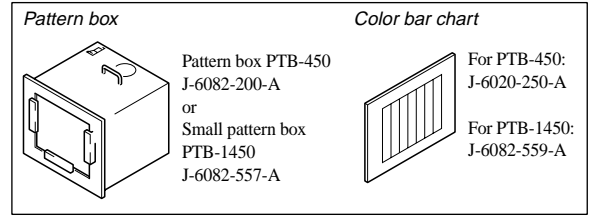

2. Adjust the distance so that the output waveform of Fig. a and the Fig. b can be obtain.

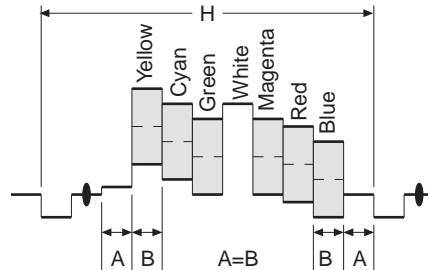

Fig. a (Video output terminal output waveform)

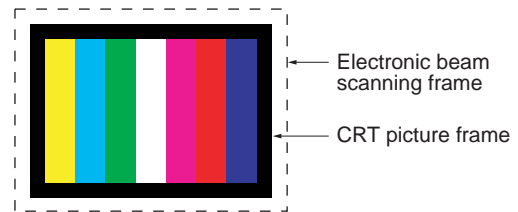

Fig. b (Picture on monitor TV)

When indicating parts by reference number, please include the board name.

Note :
The components identified by mark \triangle or dotted line with mark \triangle are critical for safety. Replace only with part number specified.

Note :
Les composants identifiés par une marque \triangle sont critiques pour la sécurité. Ne les remplacer que par une pièce portant le numéro spécifié.

4-2. SCHEMATIC DIAGRAMS

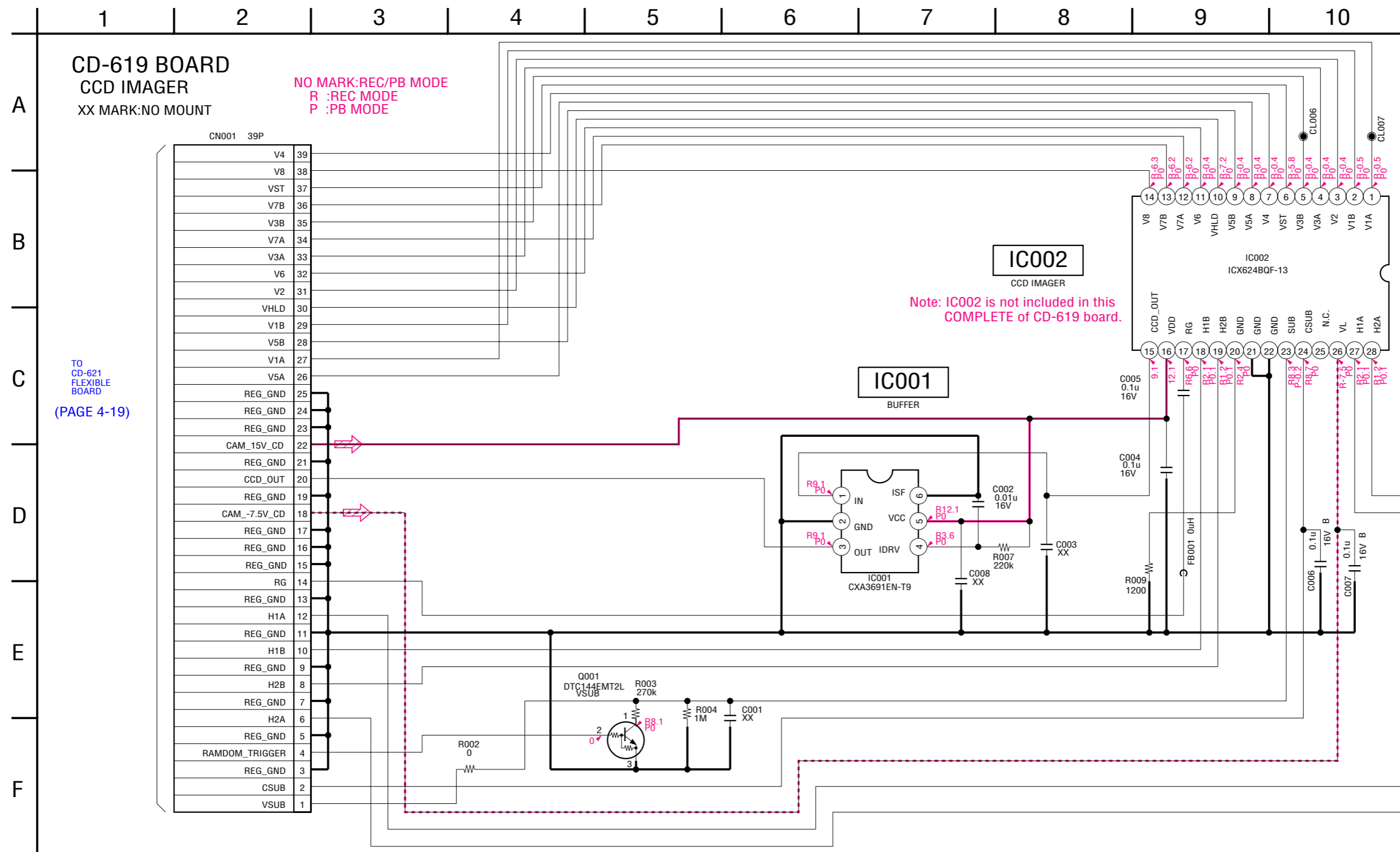

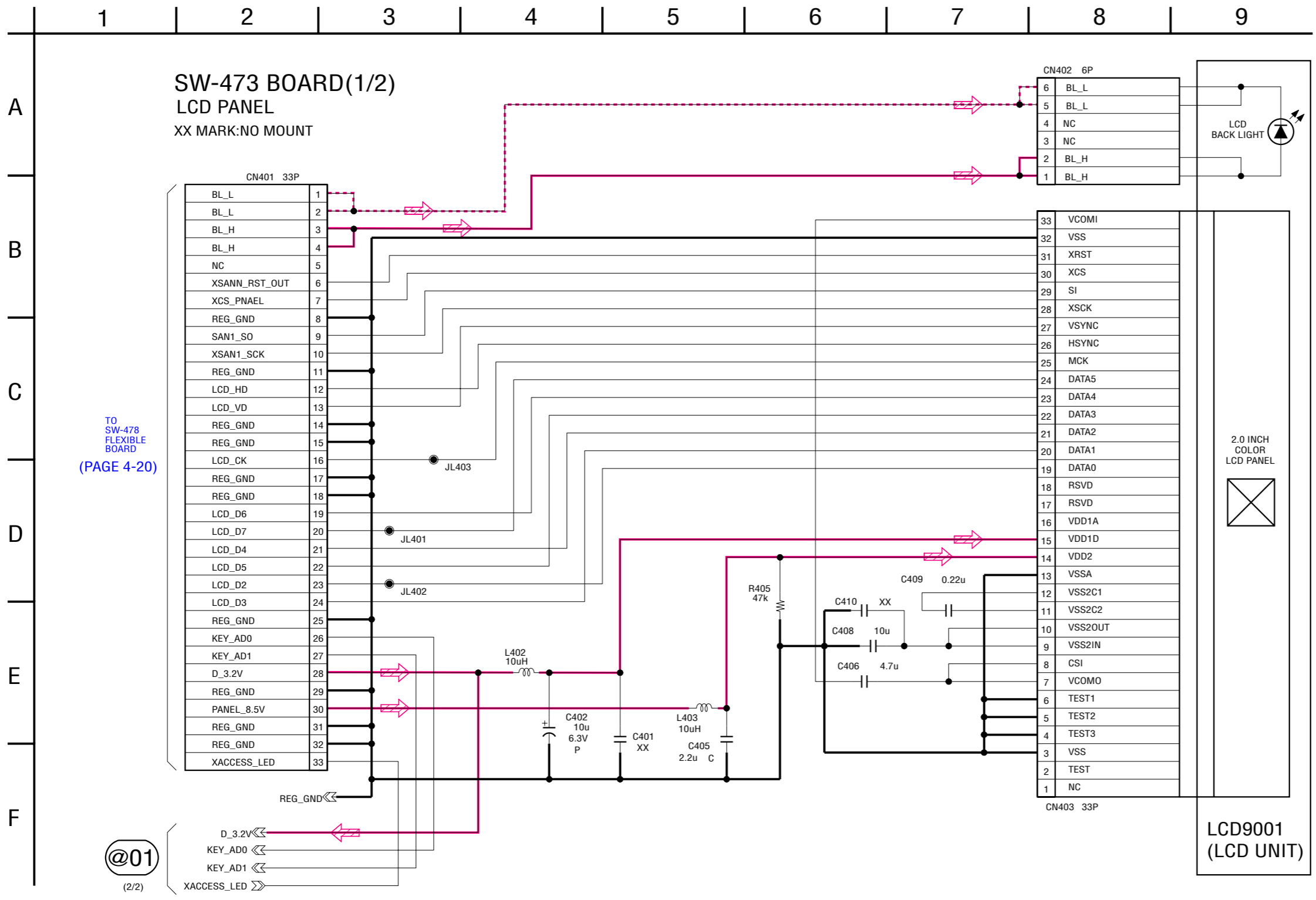

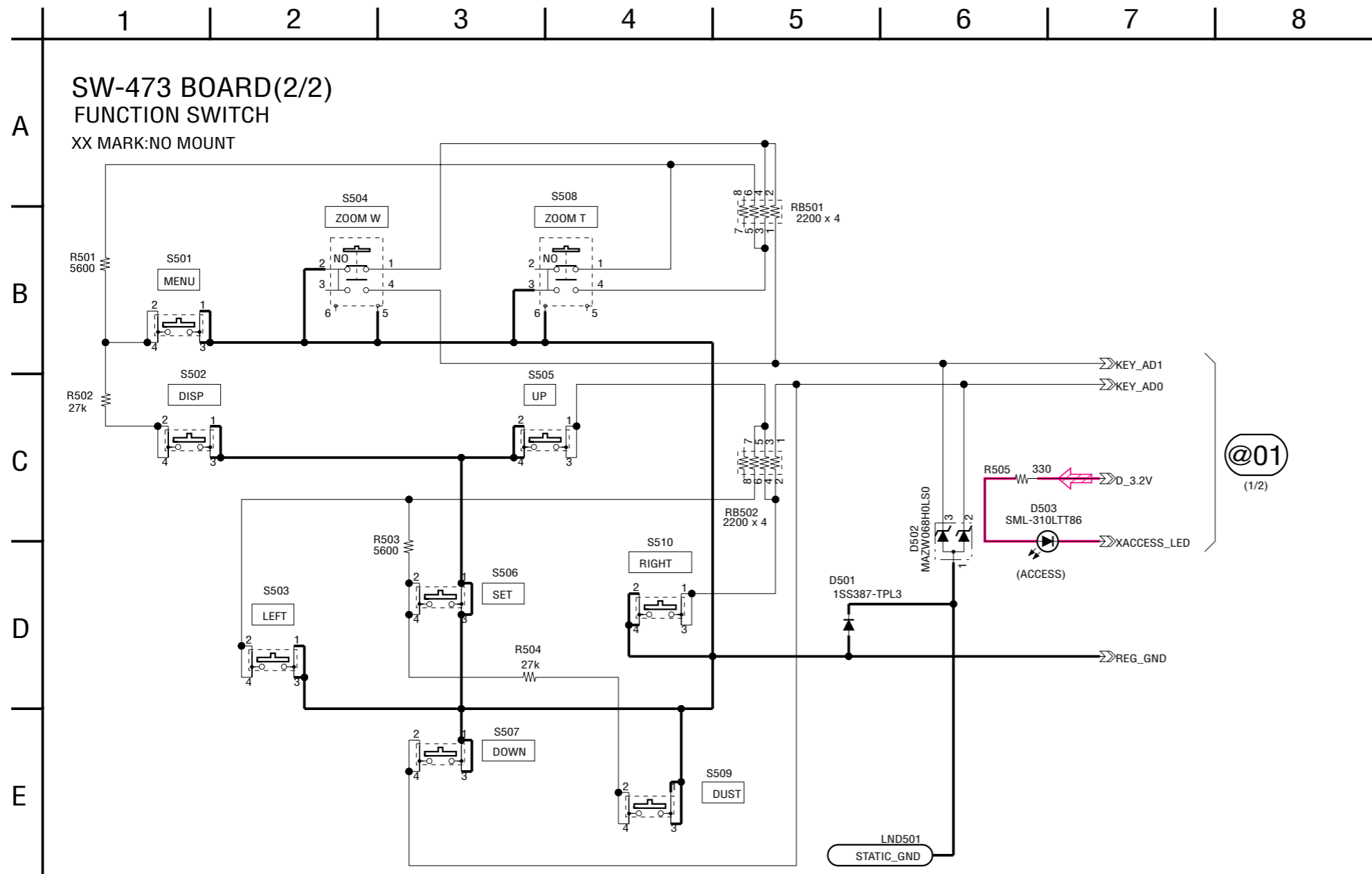

• Refer to page 4-3 for mark Δ .

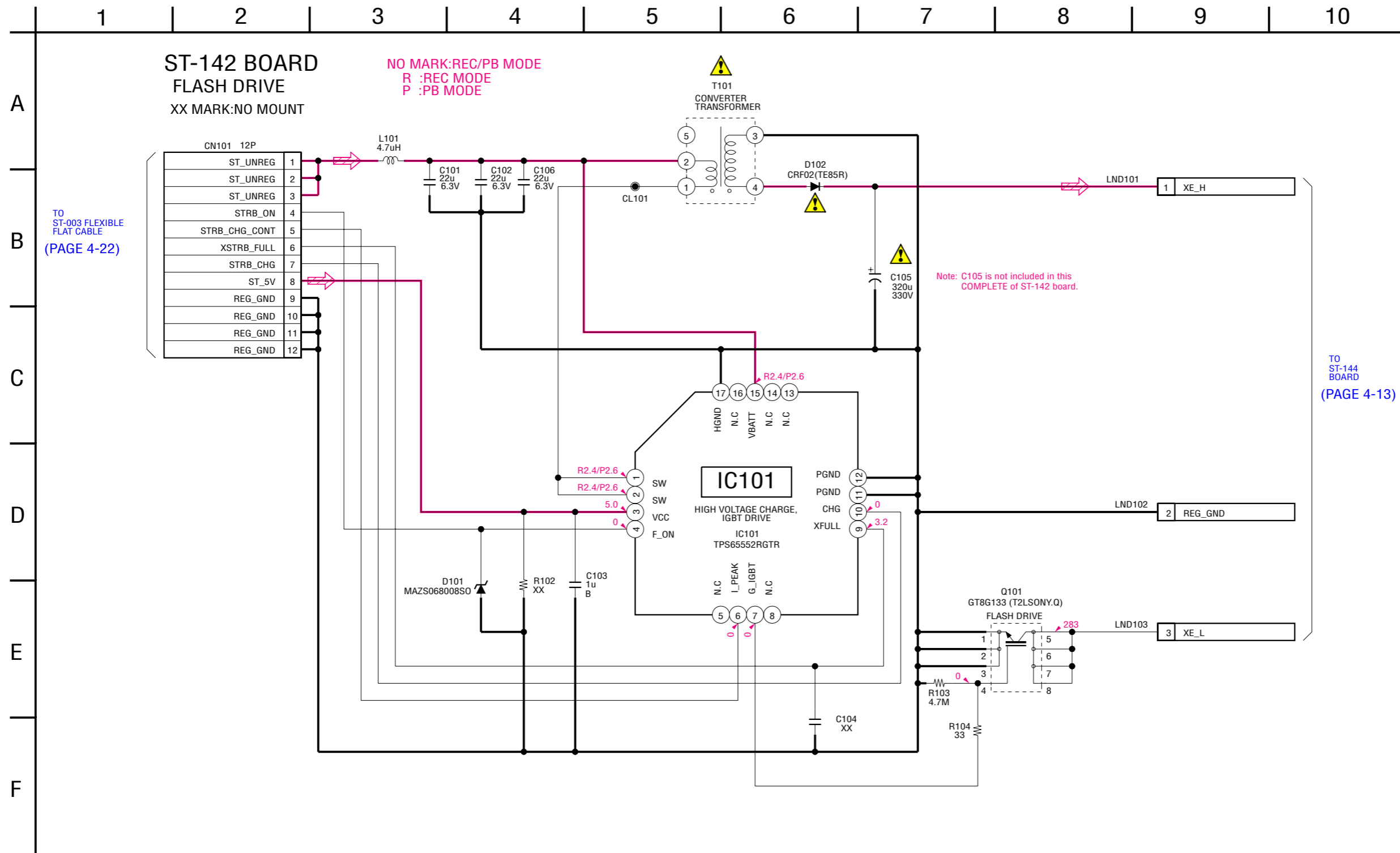

• Refer to page 4-3 for mark ▲.

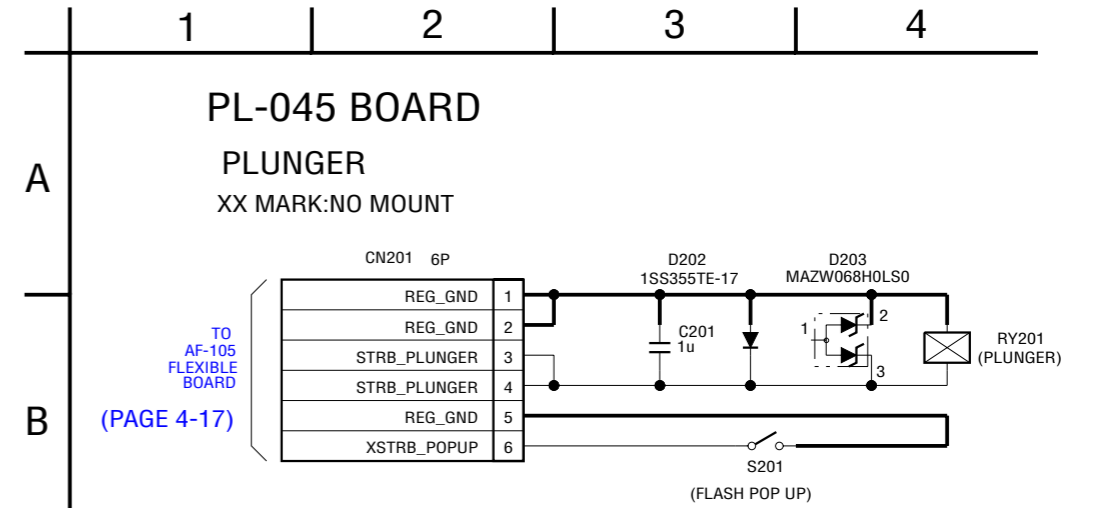
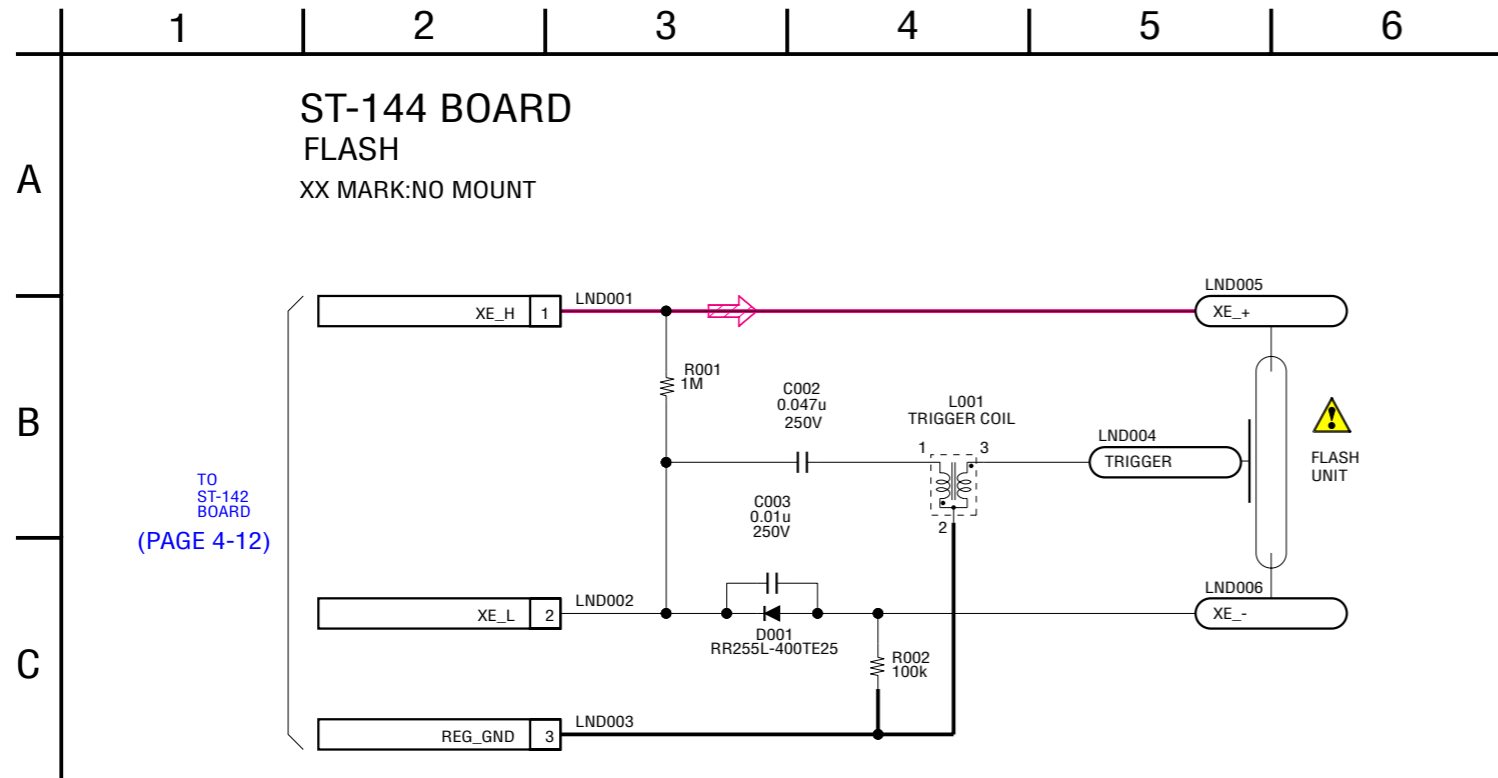

NOTE:
RY201 is not included in this COMPLETE of PL-045 board.

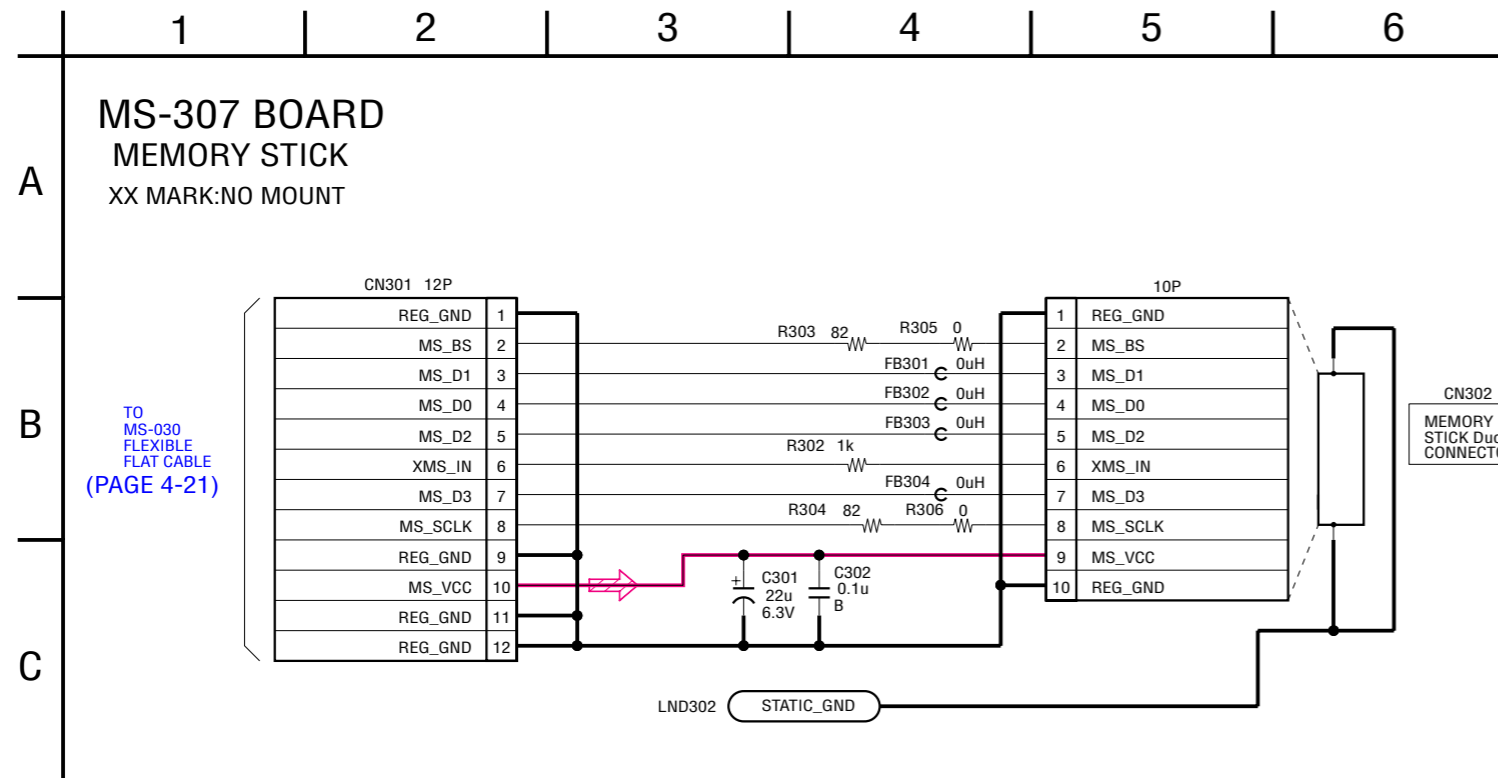

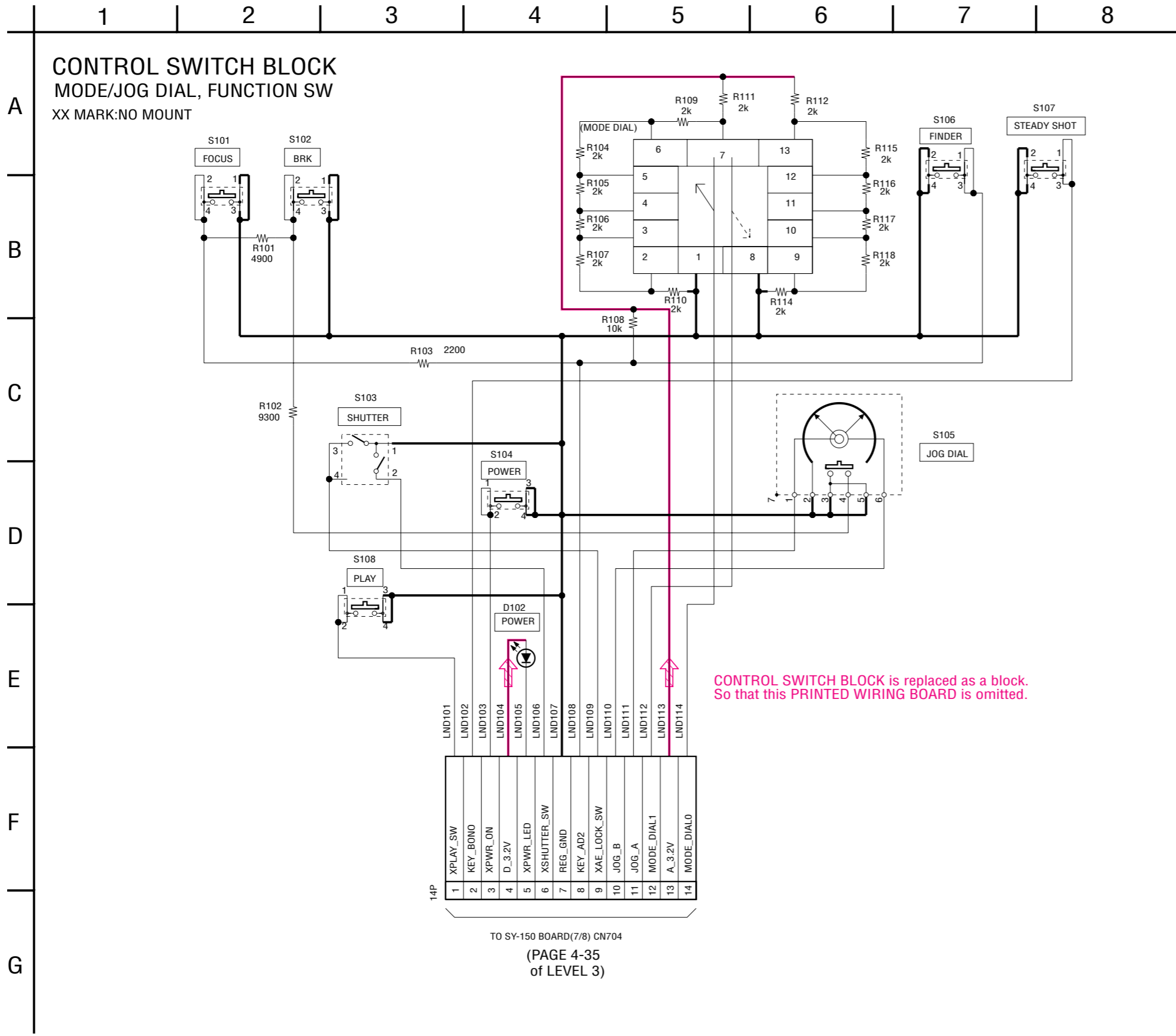

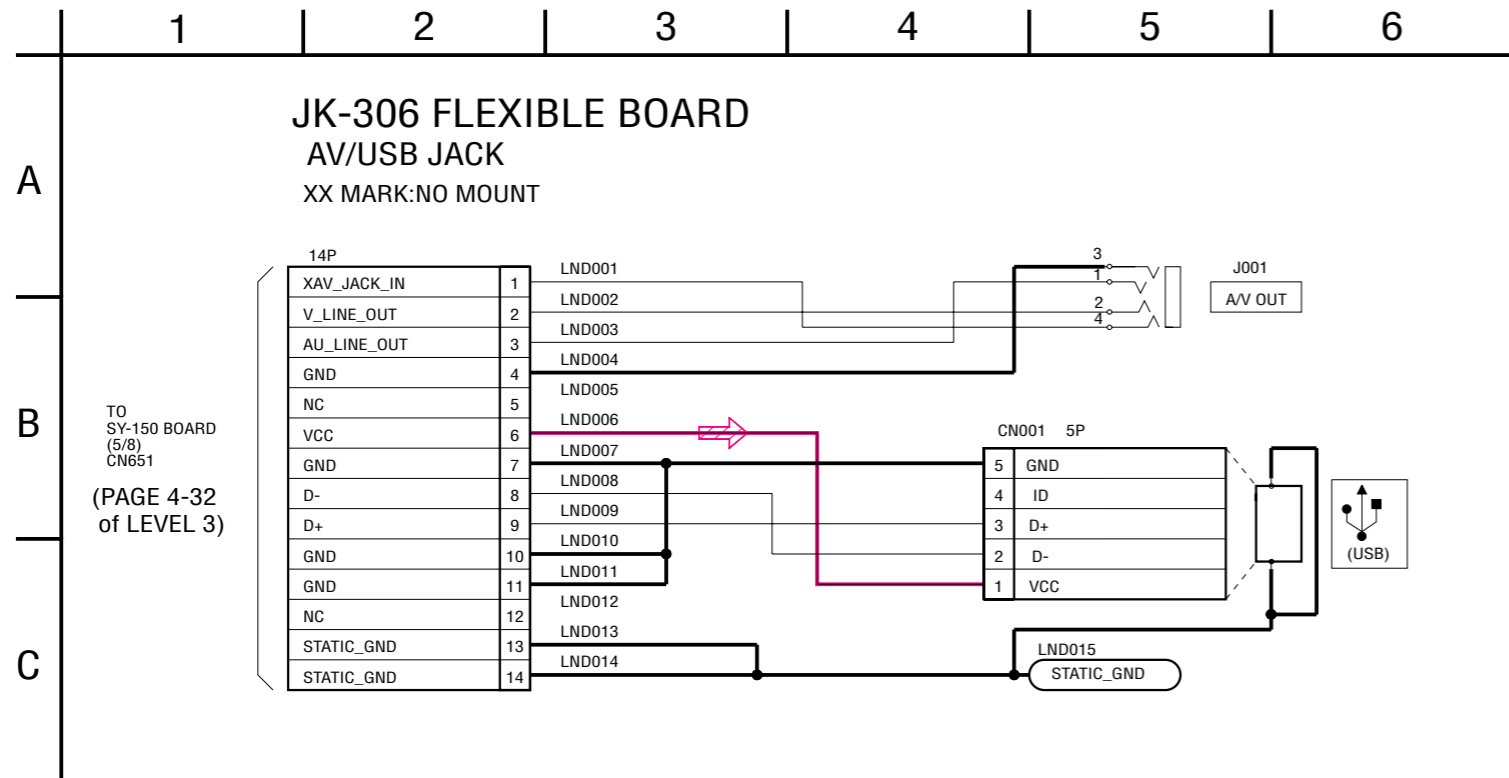
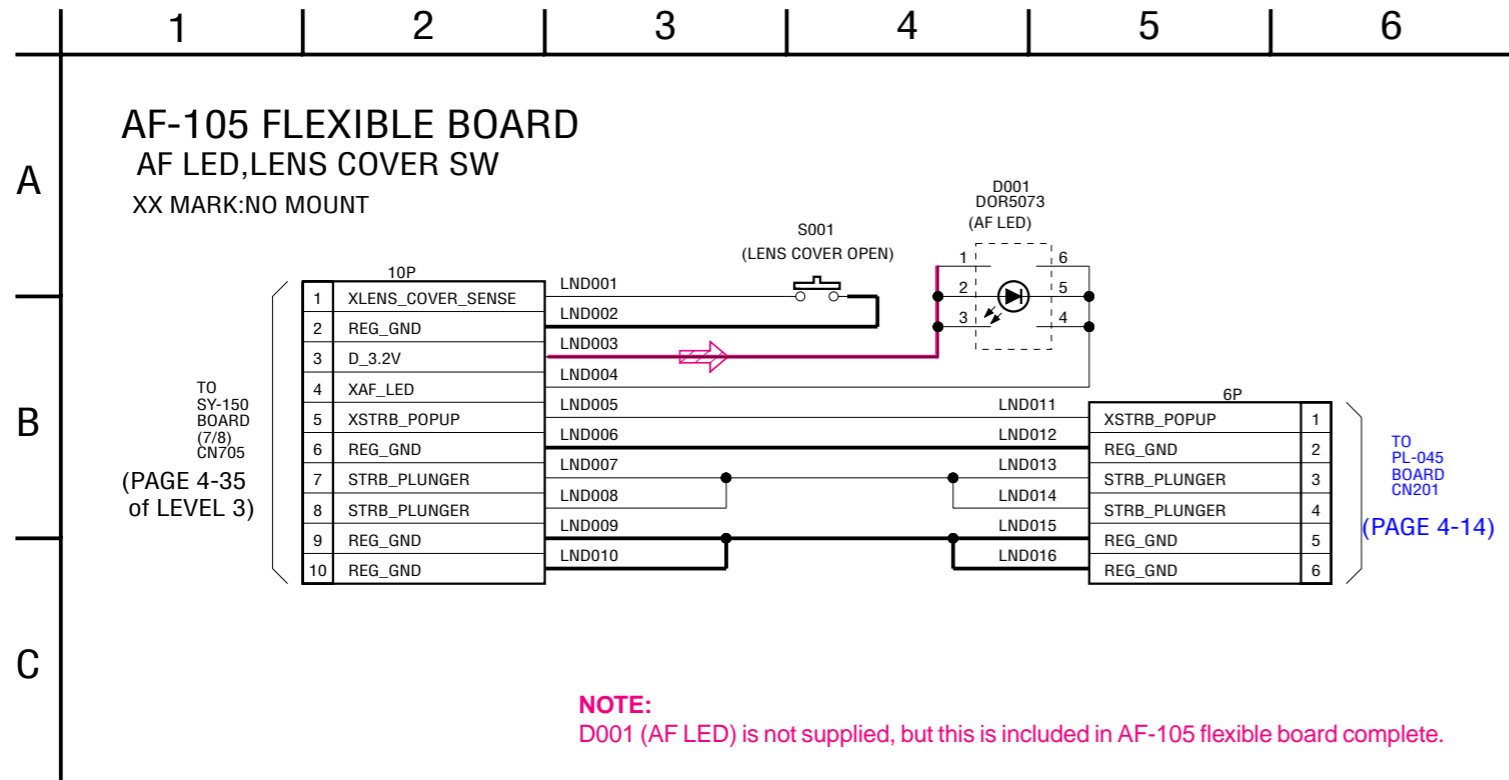

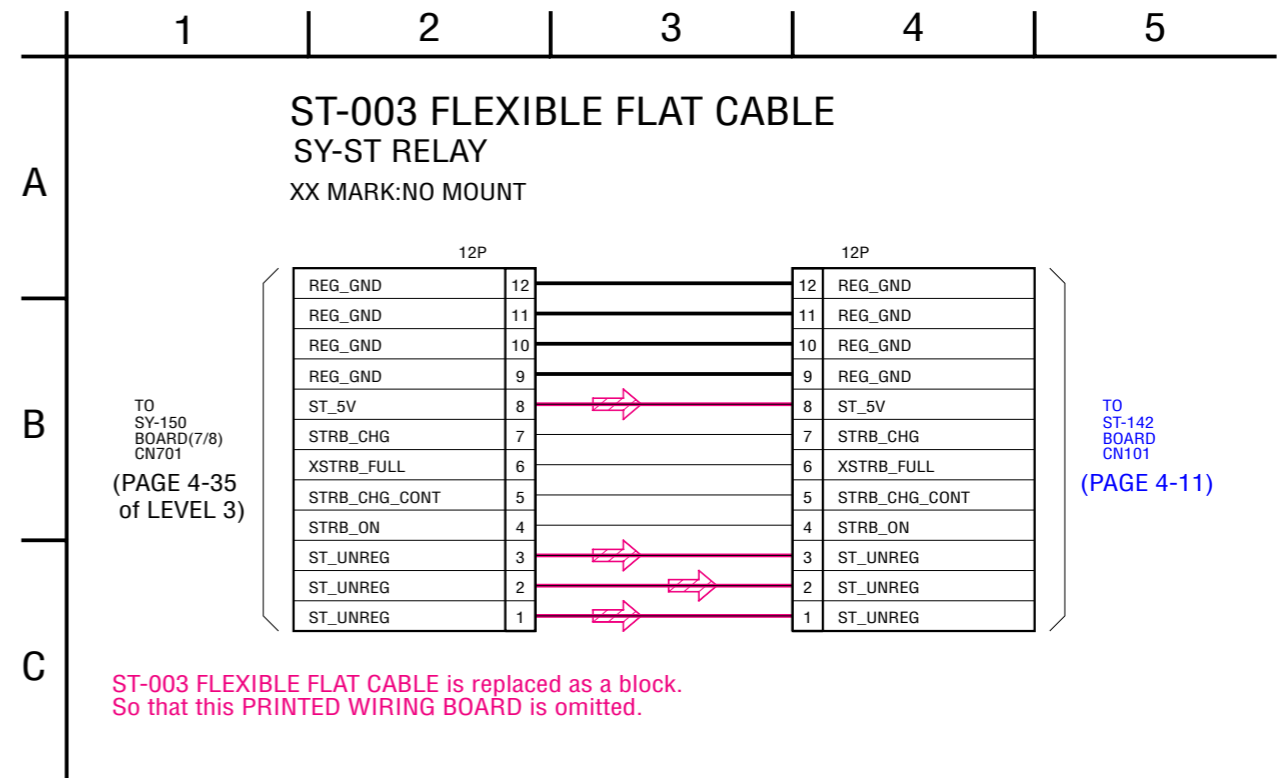
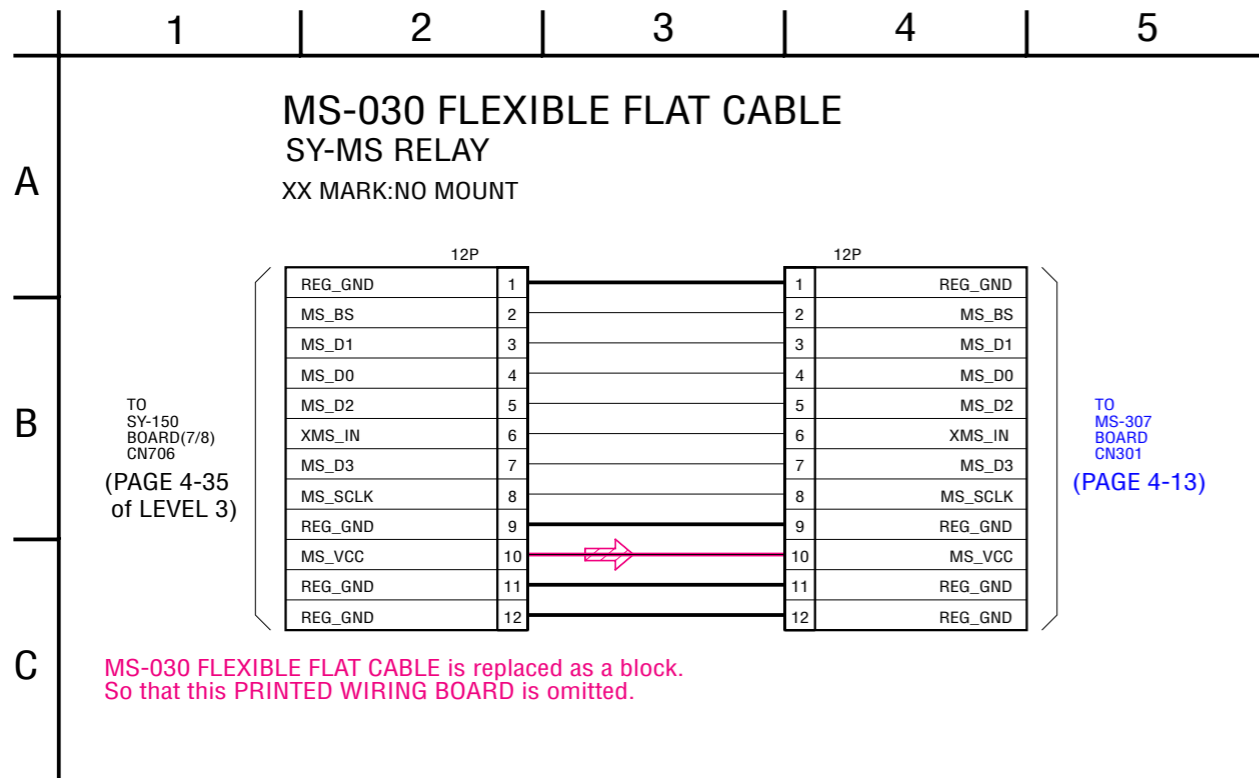

Schematic diagram of the SY-150 board and CH-169 board are not shown.
 Pages from 4-23 to 4-40 are not shown.

4-3. PRINTED WIRING BOARDS

Link

• CD-619 BOARD	• PL-045 BOARD
• SW-473 BOARD	• AF-105 FLEXIBLE BOARD
• ST-142 BOARD	• JK-306 FLEXIBLE BOARD
• ST-144 BOARD	• CD-621 FLEXIBLE BOARD
• MS-307 BOARD	• SW-478 FLEXIBLE BOARD



• COMMON NOTE FOR PRINTED WIRING BOARDS	• MOUNTED PARTS LOCATION
---	--

4-3. PRINTED WIRING BOARDS

4-3. PRINTED WIRING BOARDS

THIS NOTE IS COMMON FOR WIRING BOARDS
(In addition to this, the necessary note is printed in each block)

(For printed wiring boards)

-  : Uses unleaded solder.
-  : Pattern from the side which enables seeing.
 (The other layers' patterns are not indicated)
- Through hole is omitted.
- There are a few cases that the part printed on diagram isn't mounted in this model.
-  : panel designation

• Chip parts.

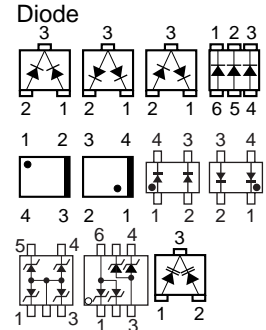
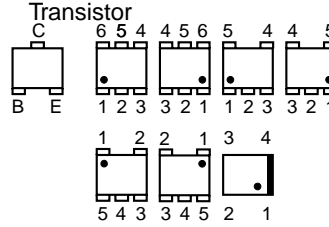

4-3. PRINTED WIRING BOARDS

CD-619 (4 layers)

•  : Uses unleaded solder.

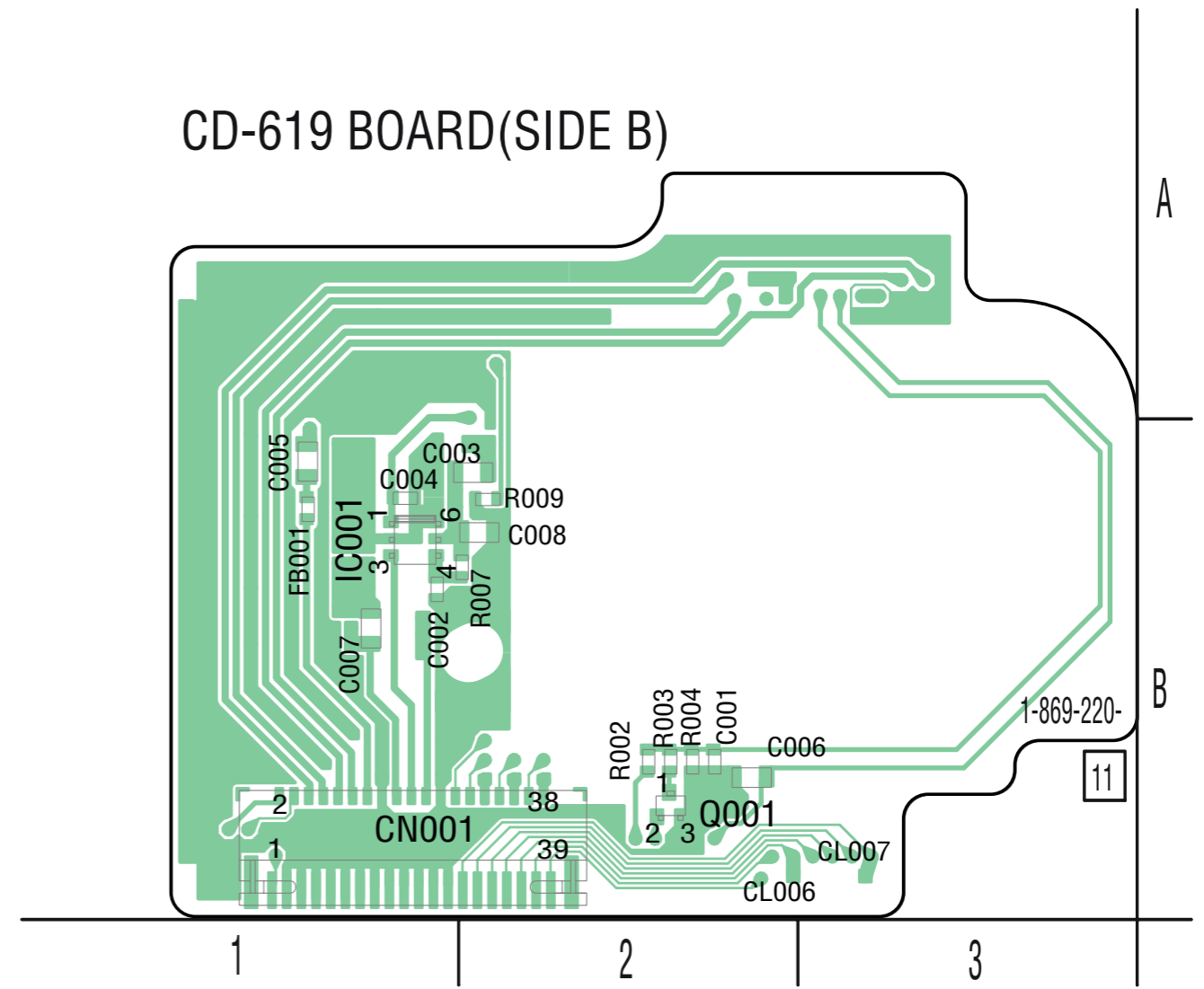
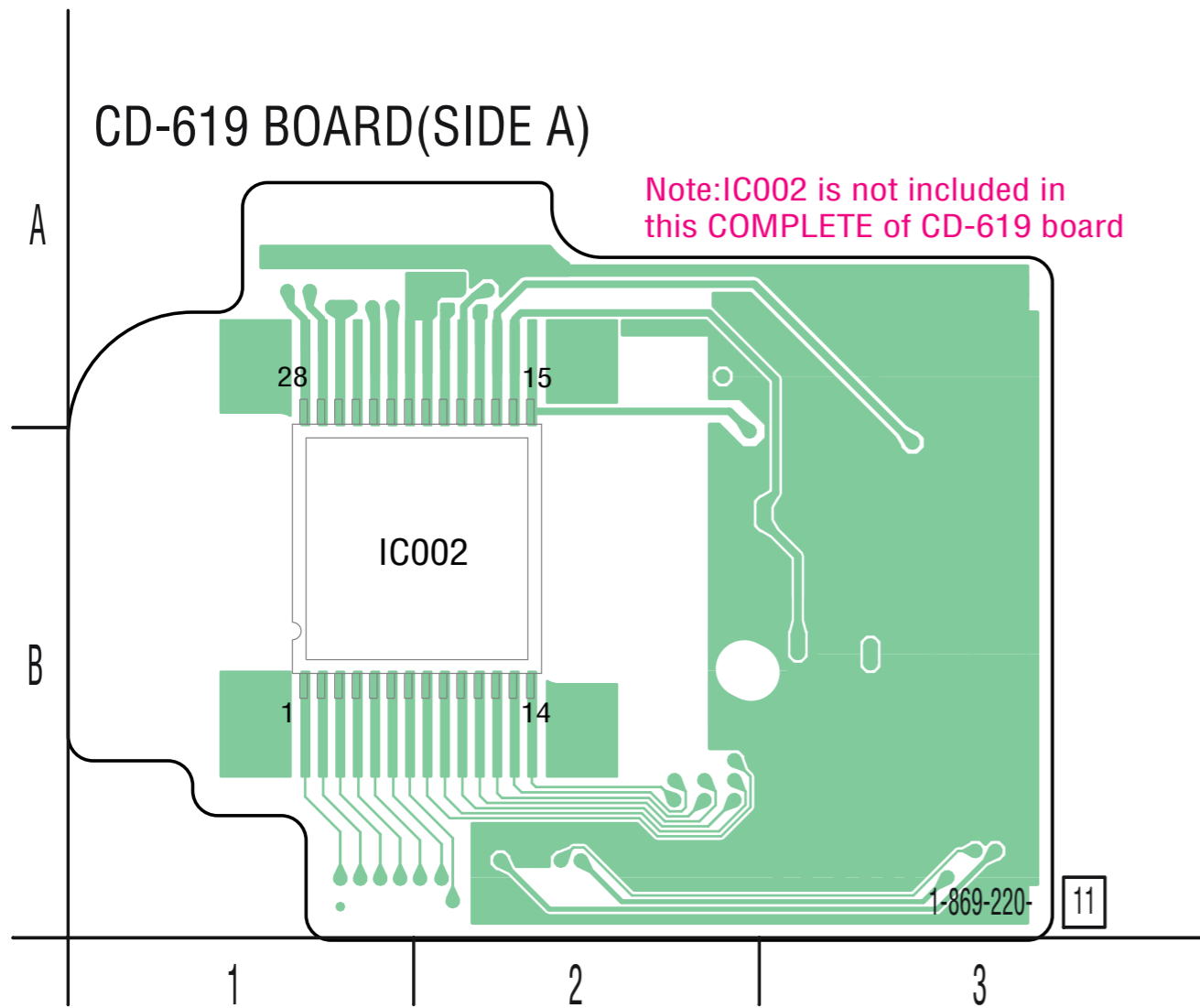

SW-473 BOARD(SIDE A)

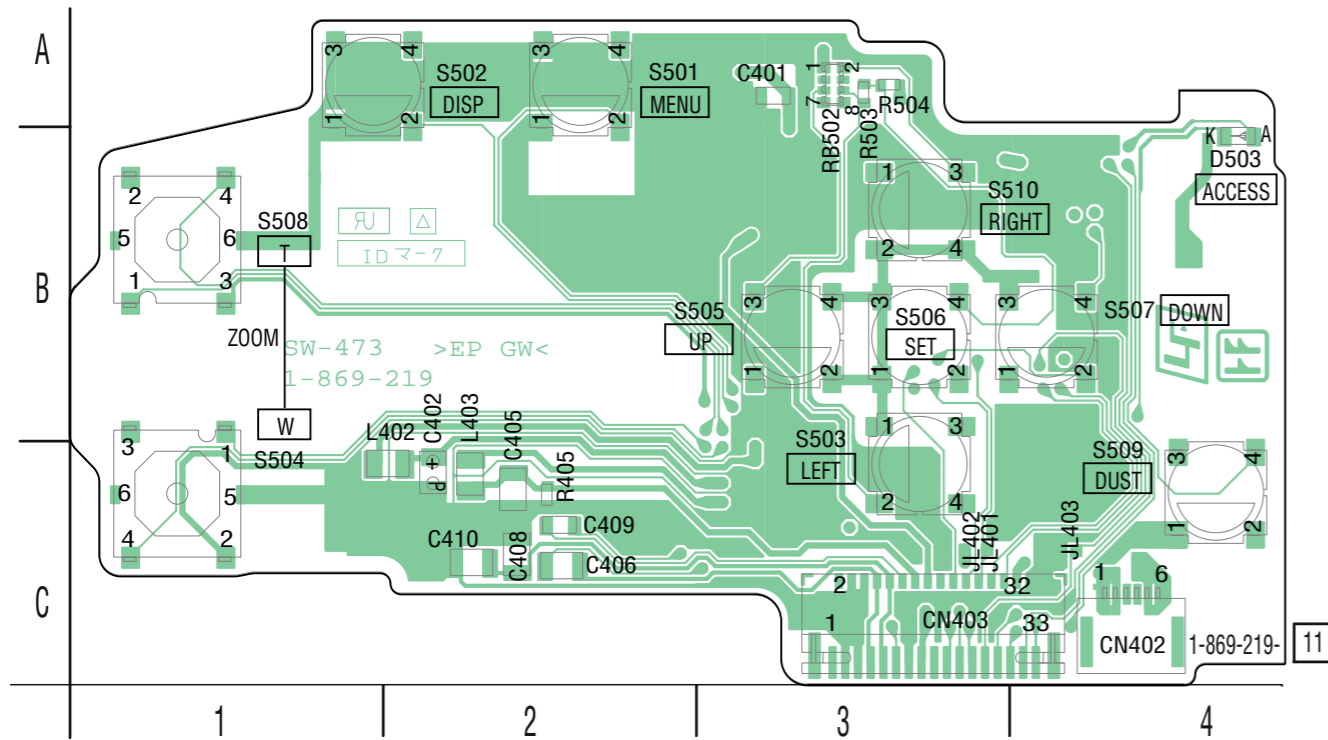

SW-473 BOARD(SIDE B)

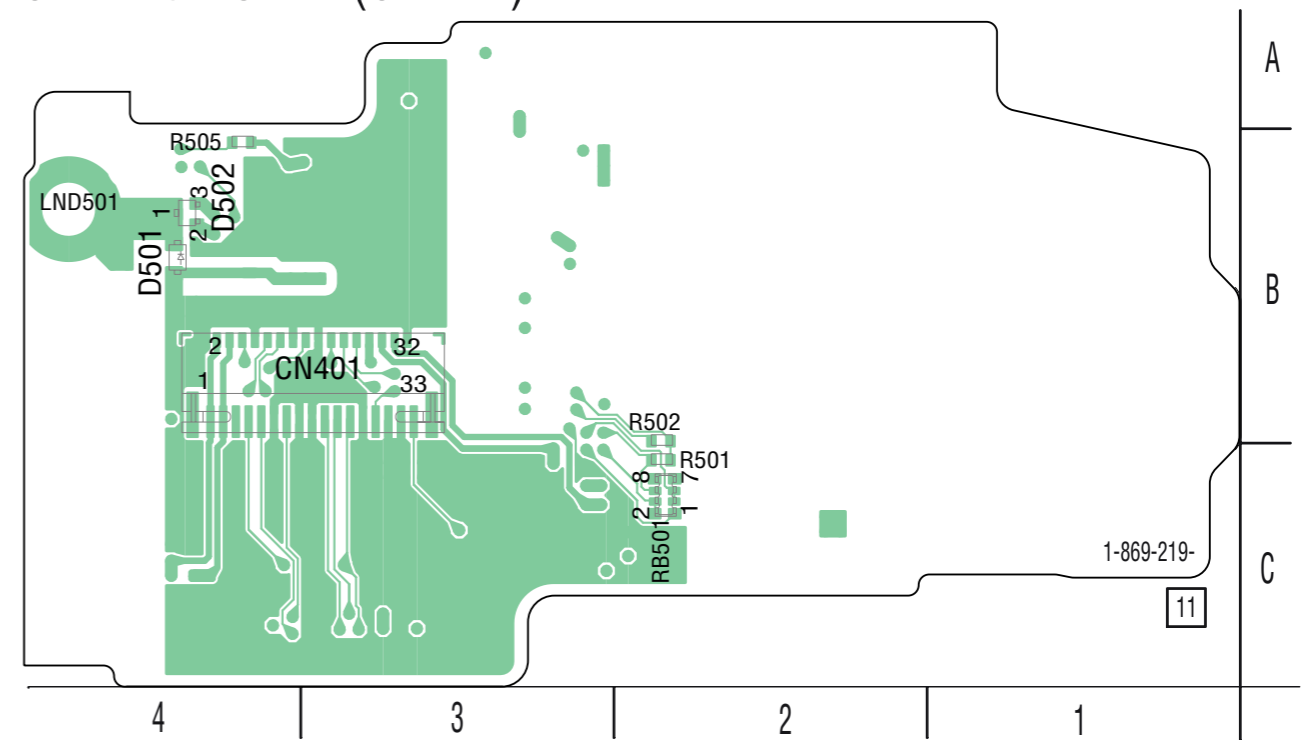

ST-142 BOARD(SIDE A)

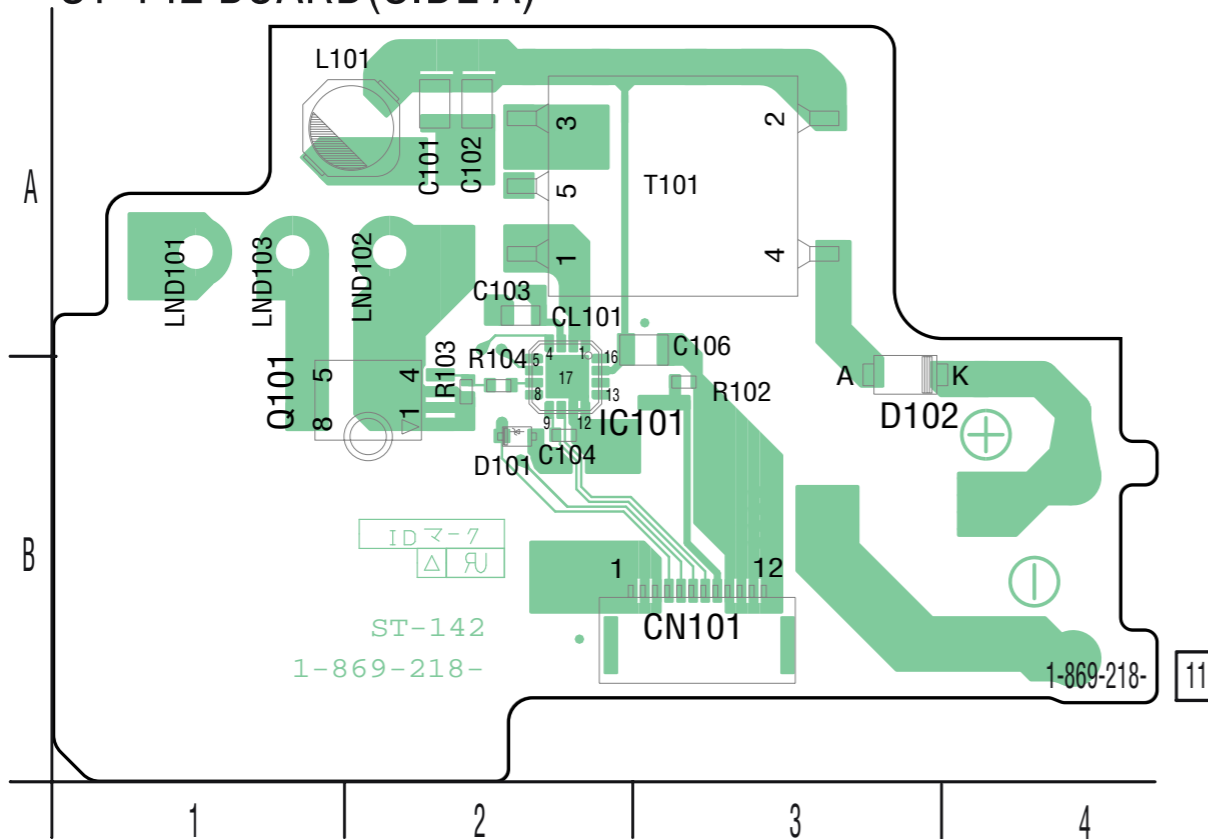

ST-142 BOARD(SIDE B)

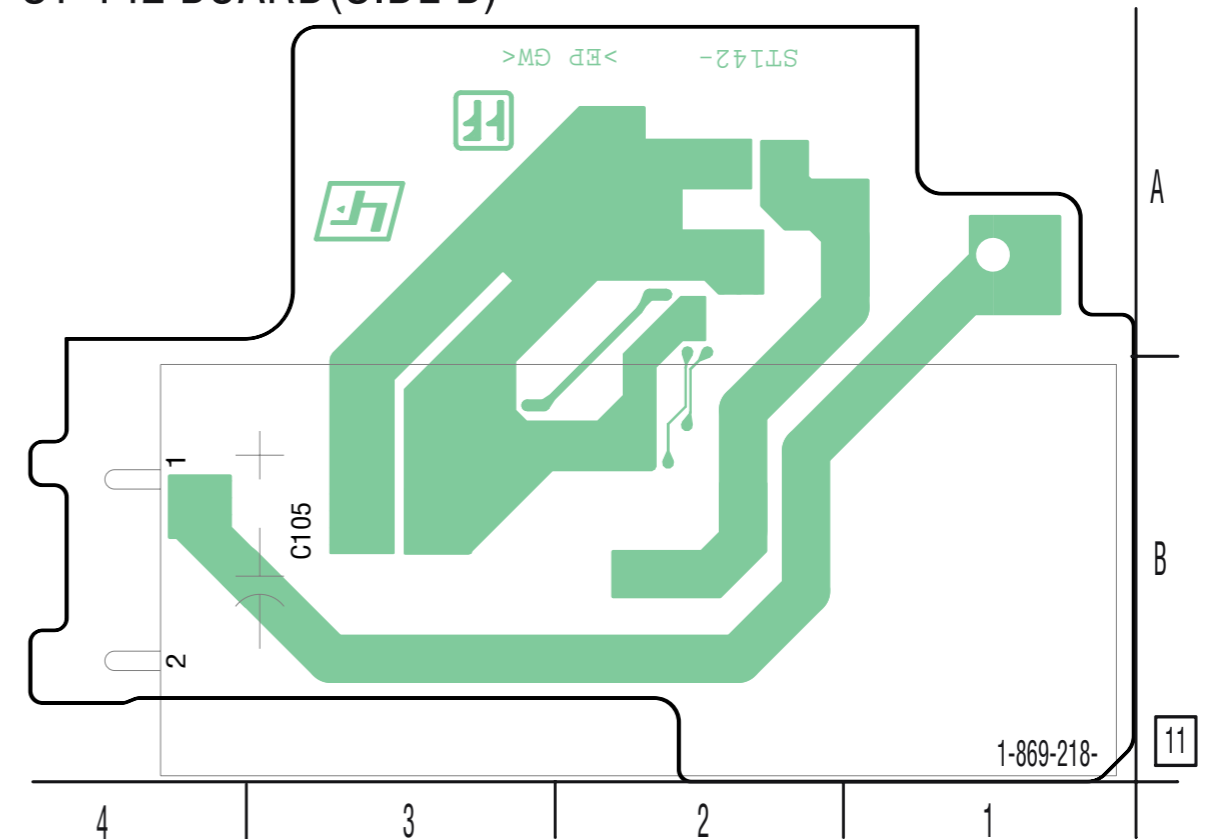

ST-144 (1 layer), MS-307 (4 layers), PL-045 (2 layers)

•  : Uses unleaded solder.

ST-144 BOARD

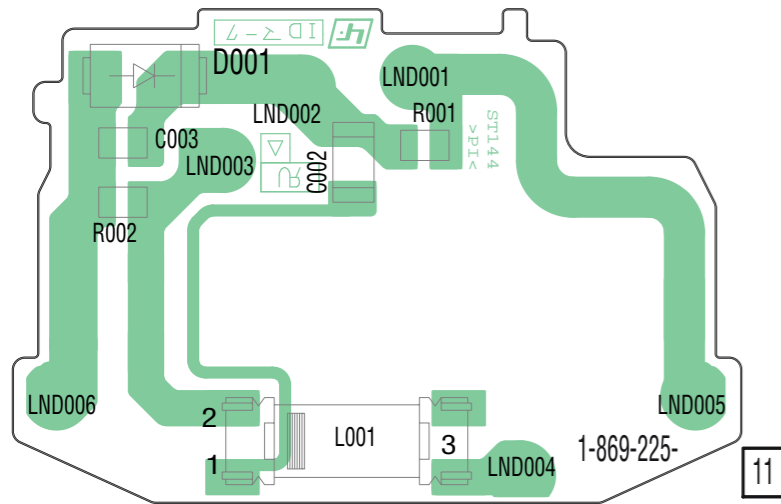

PL-045 BOARD (SIDE A)

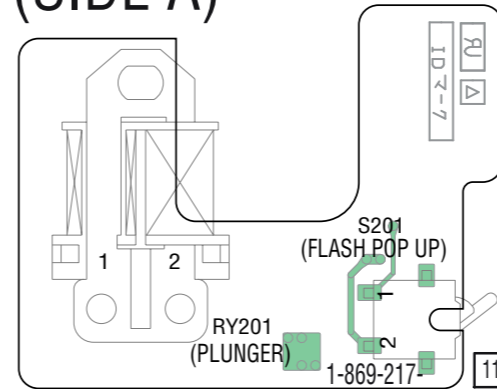

PL-045 BOARD (SIDE B)

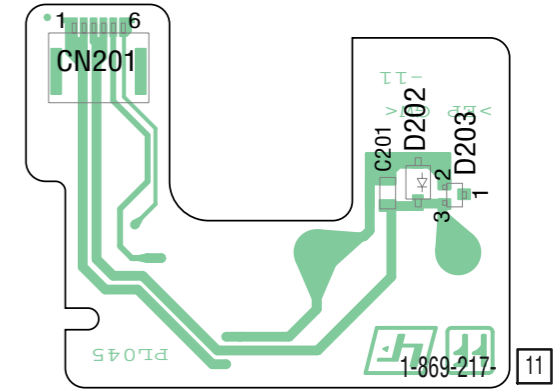

NOTE:
RY201 is not included in this COMPLETE of PL-045 board.

MS-307 BOARD(SIDE A)

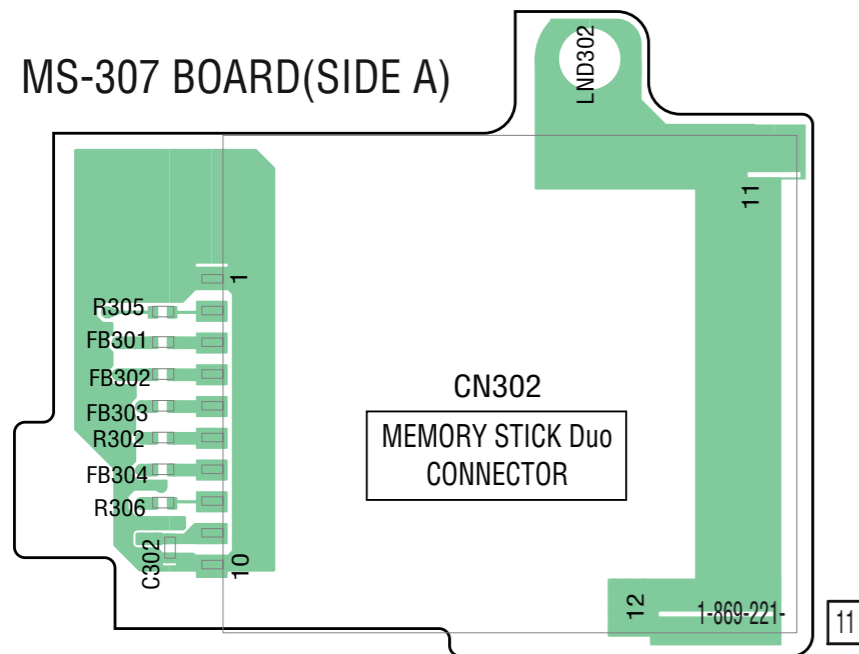

MS-307 BOARD(SIDE B)

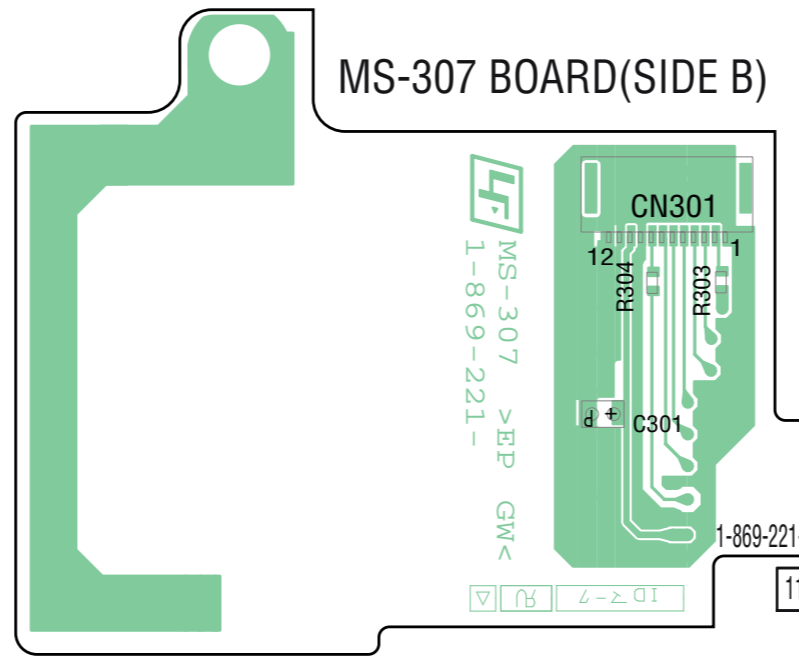

AF-105 FLEXIBLE (1 layer), JK-306 FLEXIBLE (1 layer), CD-621 FLEXIBLE (2 layers), SW-478 FLEXIBLE (1 layer) •  : Uses unleaded solder.

AF-105 FLEXIBLE BOARD

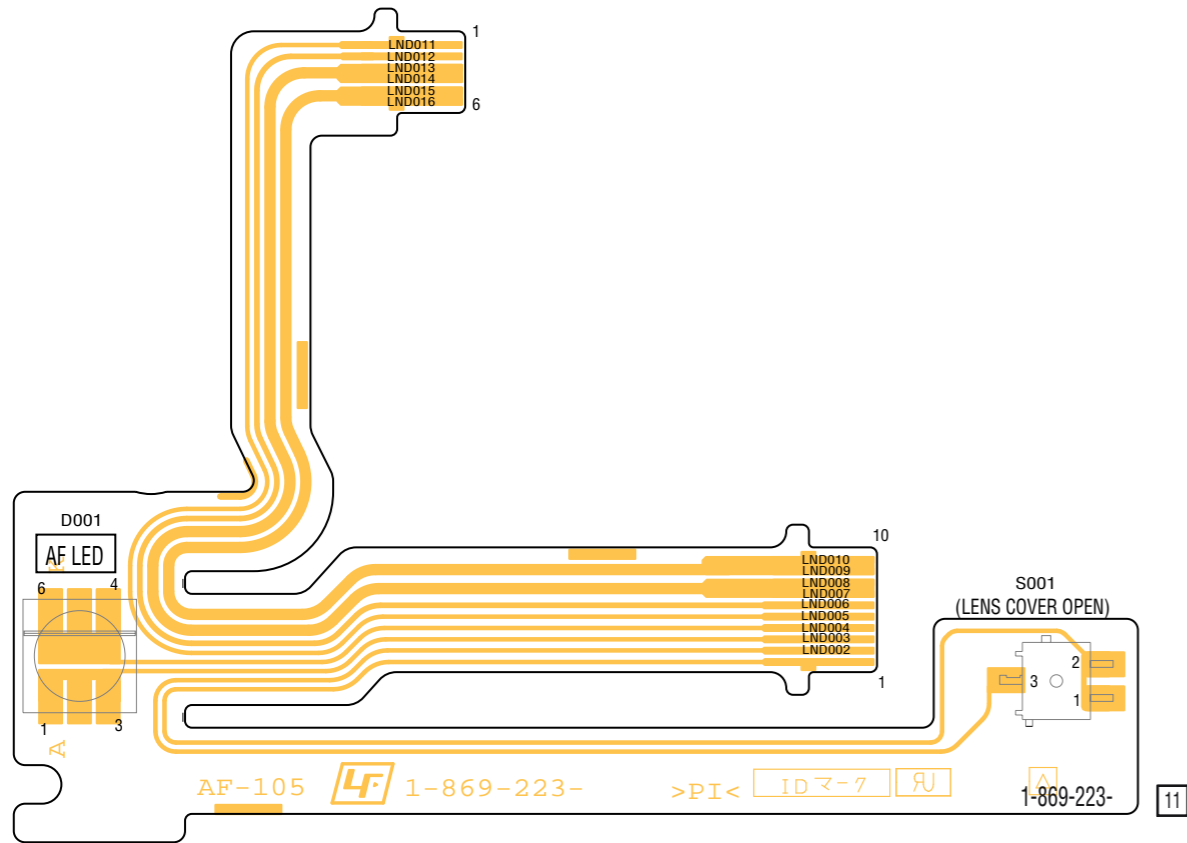

NOTE:
D001 (AF LED) is not supplied, but this is included in AF-105 flexible board complete.

JK-306 FLEXIBLE BOARD

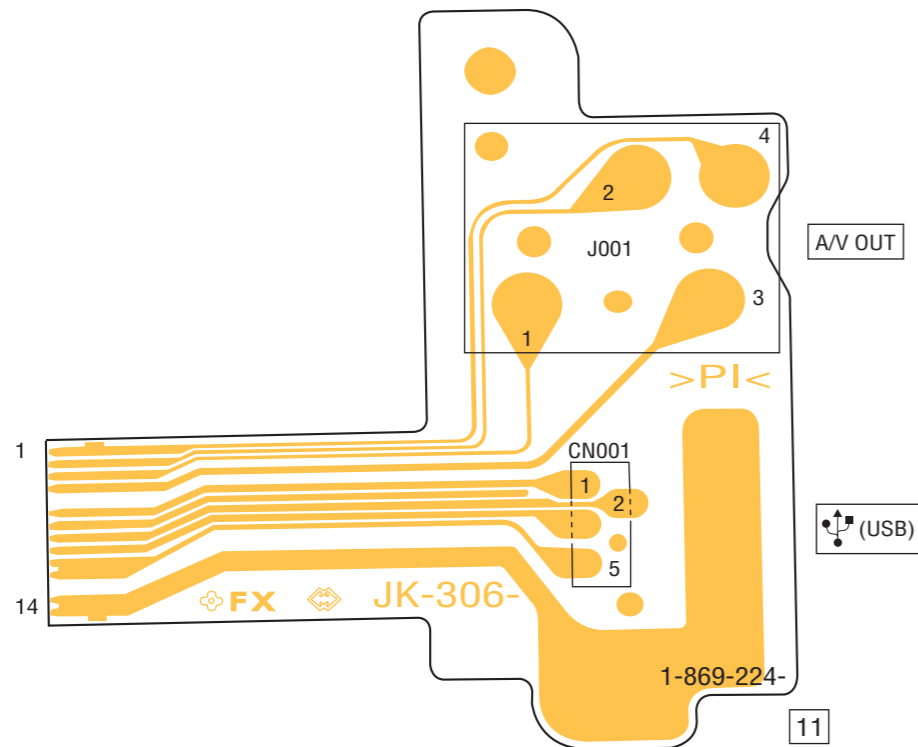

CD-621 FLEXIBLE BOARD

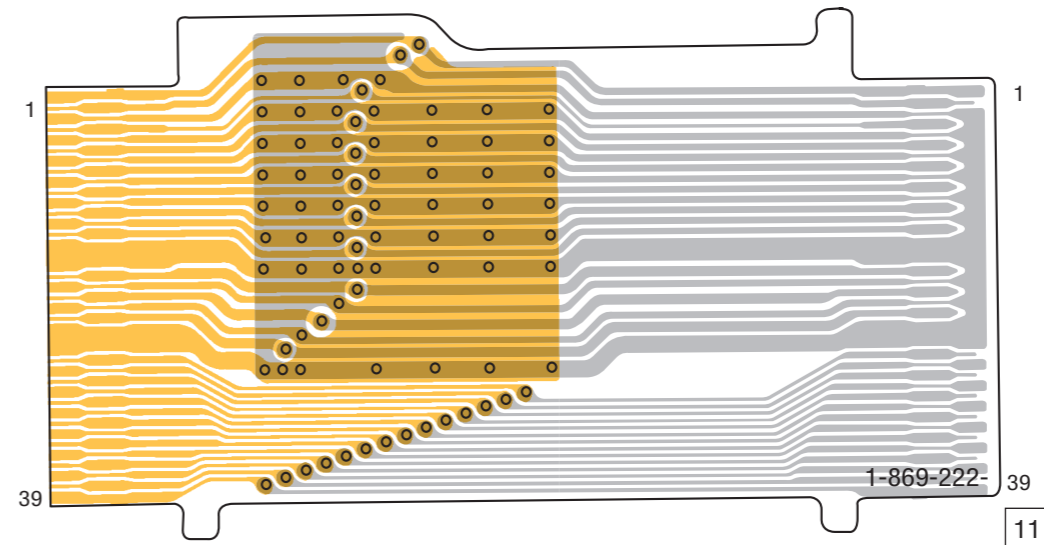

SW-478 FLEXIBLE BOARD

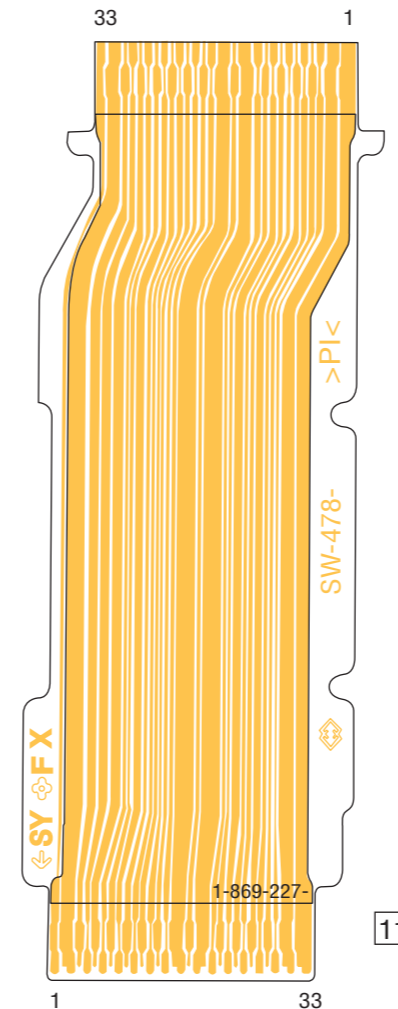

Printed wiring board of the SY-150 board and CH-169 board are not shown.
Pages from 4-51 to 4-55 are not shown.

4-3. PRINTED WIRING BOARDS

4-4. MOUNTED PARTS LOCATION

no mark : side A
* mark : side B

CD-619 BOARD

* C001 B-2
* C002 B-1
* C003 B-1
* C004 B-1
* C005 B-1
* C006 B-2
* C007 B-1
* C008 B-2

* CL006 B-2
* CL007 B-3

* CN001 B-1

* FB001 B-1

* IC001 B-1
IC002 B-2

* Q001 B-2

* R002 B-2
* R003 B-2
* R004 B-2
* R007 B-1
* R009 B-2

SW-473 BOARD

C401 A-3
C402 B-2
C405 B-2
C406 C-2
C408 C-2
C409 C-2
C410 C-2

* CN401 B-4
CN402 C-4
CN403 C-3

* D501 B-4
* D502 B-4
D503 B-4

JL401 C-3
JL402 C-3
JL403 C-4

L402 B-2
L403 B-2

* LND501 B-4

R405 C-2
* R501 C-2
* R502 C-2
R503 B-3
R504 A-3
* R505 B-4

* RB501 C-2
RB502 B-3

S501 A-2
S502 A-2
S503 B-3
S504 C-1
S505 B-2
S506 B-3
S507 B-4
S508 B-1
S509 B-4
S510 B-3

ST-142 BOARD

C101 A-2
C102 A-2
C103 A-2
C104 B-2
* C105 B-3
C106 B-3

CL101 A-2

CN101 B-3

D101 B-2
D102 B-3

IC101 B-3

L101 A-1

LND101 A-1
LND102 A-2
LND103 A-1

Q101 B-1

R102 B-3
R103 B-2
R104 B-2

T101 A-3

Mounted parts location of the SY-150 board is not shown.
Page 4-57 is not shown.

5. REPAIR PARTS LIST

NOTE: Characters **A** to **Z** of the electrical parts list indicate location of exploded views in which the desired part is shown.

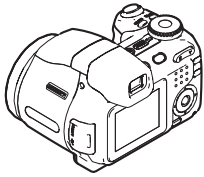
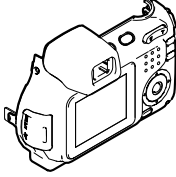
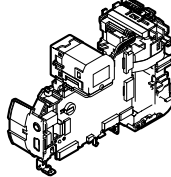
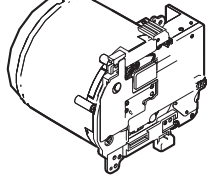
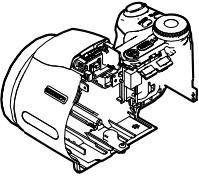
Link	EXPLODED VIEWS		
 F		 I C B	 D
OVERALL SECTION	CABINET (REAR) SECTION	MAIN SECTION	LENS SECTION
 A	 H C E		
CABINET (FRONT) SECTION	ST SECTION		

Link	ELECTRICAL PARTS LIST		ACCESSORIES
• AF-105 FLEXIBLE BOARD A	• MS-307 BOARD B	• ST-144 BOARD C	
• CD-619 BOARD D	• PL-045 BOARD E	• SW-473 BOARD F	
• JK-306 FLEXIBLE BOARD G	• ST-142 BOARD H	• SY-150 BOARD I	

5. REPAIR PARTS LIST

5. REPAIR PARTS LIST

NOTE:

- -XX, -X mean standardized parts, so they may have some differences from the original one.
- Items marked “*” are not stocked since they are seldom required for routine service. Some delay should be anticipated when ordering these items.
- The mechanical parts with no reference number in the exploded views are not supplied.
- Due to standardization, replacements in the parts list may be different from the parts specified in the diagrams or the components used on the set.
- **CAPACITORS:**
 uF: μ F
 COILS
 uH: μ H
- **RESISTORS**
 All resistors are in ohms.
 METAL: metal-film resistor
 METAL OXIDE: Metal Oxide-film resistor
 F: nonflammable
- **SEMICONDUCTORS**
 In each case, u: μ , for example:
 uA...: μ A..., uPA..., μ PA...,
 uPB..., μ PB..., uPC..., μ PC...,
 uPD..., μ PD...

When indicating parts by reference number, please include the board name.

The components identified by mark Δ or dotted line with mark Δ are critical for safety. Replace only with part number specified.

Les composants identifiés par une marque Δ sont critiques pour la sécurité. Ne les remplacer que par une pièce portant le numéro spécifié.

Language that can be selected about SY-150 board

	Area	English	French	German	Spanish	Italian	Portugal	Simplified Chinese	Traditional Chinese	Arabic	Dutch	Russian	Swedish	Korean	Norwegian	Danish	Finnish	Polish	Hungarian	Czech	Persian	Thai	
GP2	US CND AUS Vietnam	●	●		●	●		●	●														
GP3	AEP UK	●	●	●	●	●	●				●	●	●		●	●	●	●	●	●	●		
GP4	E AR JE HK CH KR	●			●		●	●	●	●				●								●	●

- Abbreviation
 AR : Argentine model
 AUS : Australian model
 CH : Chinese model
 CND : Canadian model
 HK : Hong Kong model
 JE : Tourist model
 KR : Korea model

5. REPAIR PARTS LIST

5-1. EXPLODED VIEWS

5-1-1. OVERALL SECTION

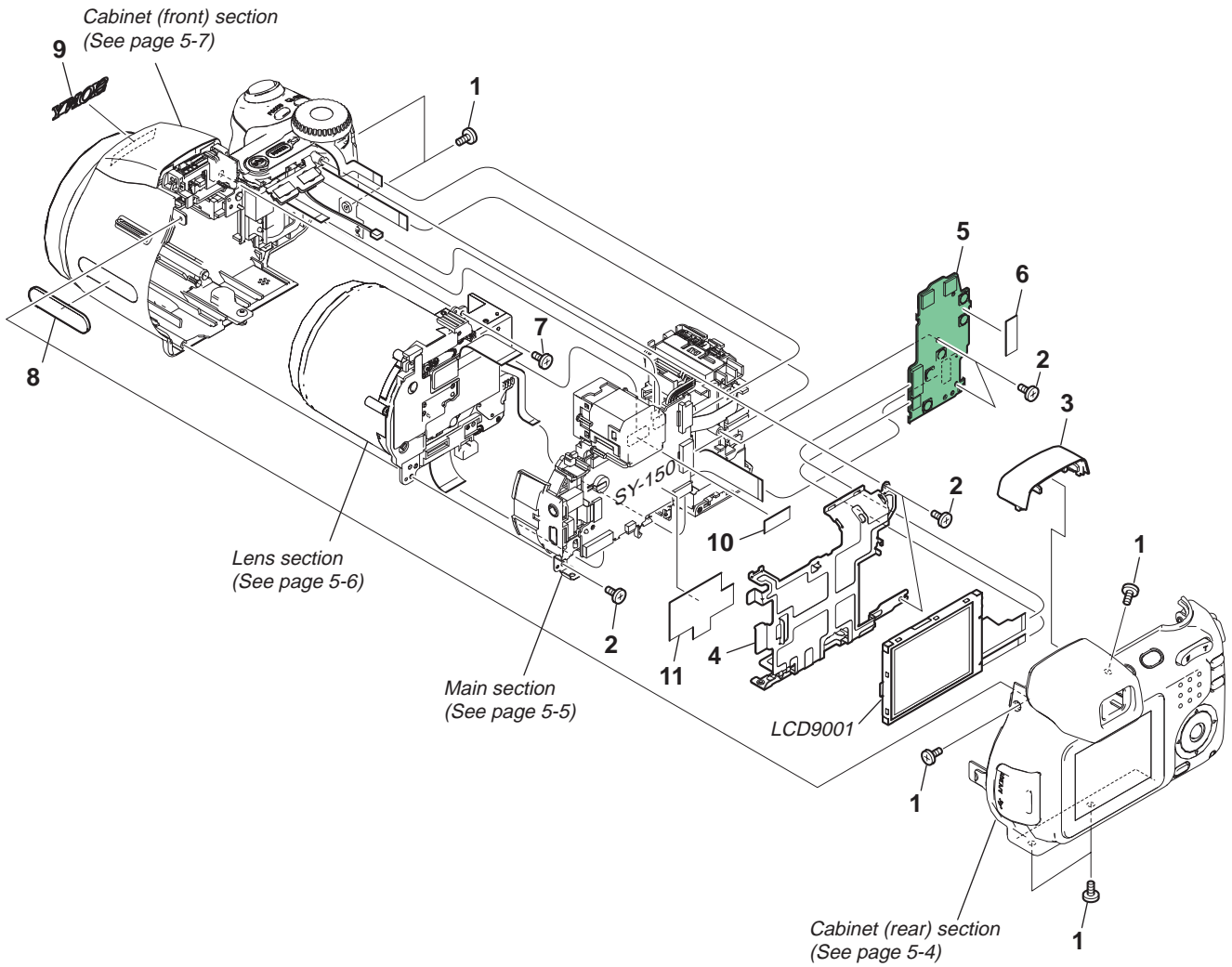

Ref. No.	Part No.	Description
1	2-655-582-11	SCREW 0+P2 M2 NEWTRU-STAR
2	3-080-204-11	SCREW, TAPPING, P2
3	2-673-327-01	CABINET (UPPER)
* 4	2-673-307-01	FRAME, LCD
5	A-1176-910-A	SW-473 BOARD, COMPLETE
* 6	2-678-099-01	SHEET, SW MUFFLE

Ref. No.	Part No.	Description
7	2-666-551-21	SCREW, TAPPING, P2
8	2-673-346-01	PLATE, ORNAMENTAL
9	2-673-341-01	EMBLEM (320), ST
* 10	2-685-307-01	RETAINER, TAPE (CD)
* 11	2-673-339-01	LABEL, FUSE REPLACEMENT CAUTION
LCD9001	8-753-248-51	ACX351AKM-3

5. REPAIR PARTS LIST

5-1-2. CABINET (REAR) SECTION

ns : not supplied

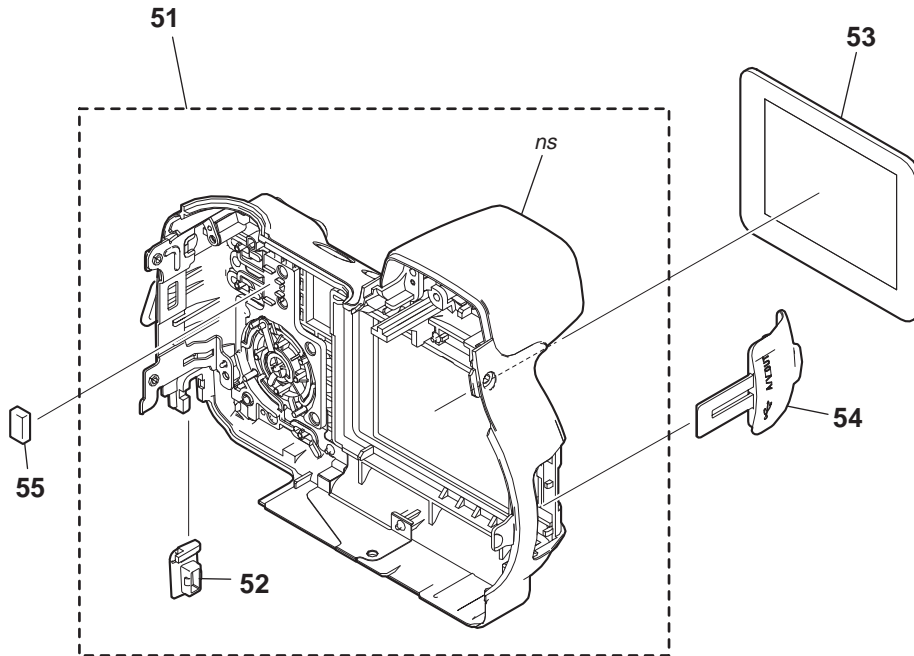

Ref. No.	Part No.	Description
51	X-2108-908-1	CABINET (REAR) ASSY
52	2-673-247-01	LID, DC
53	2-673-333-01	WINDOW, LCD

Ref. No.	Part No.	Description
54	2-673-303-01	LID, JK
* 55	2-685-484-01	CUSHION (REAR)

5. REPAIR PARTS LIST

5-1-3. MAIN SECTION

ns : not supplied

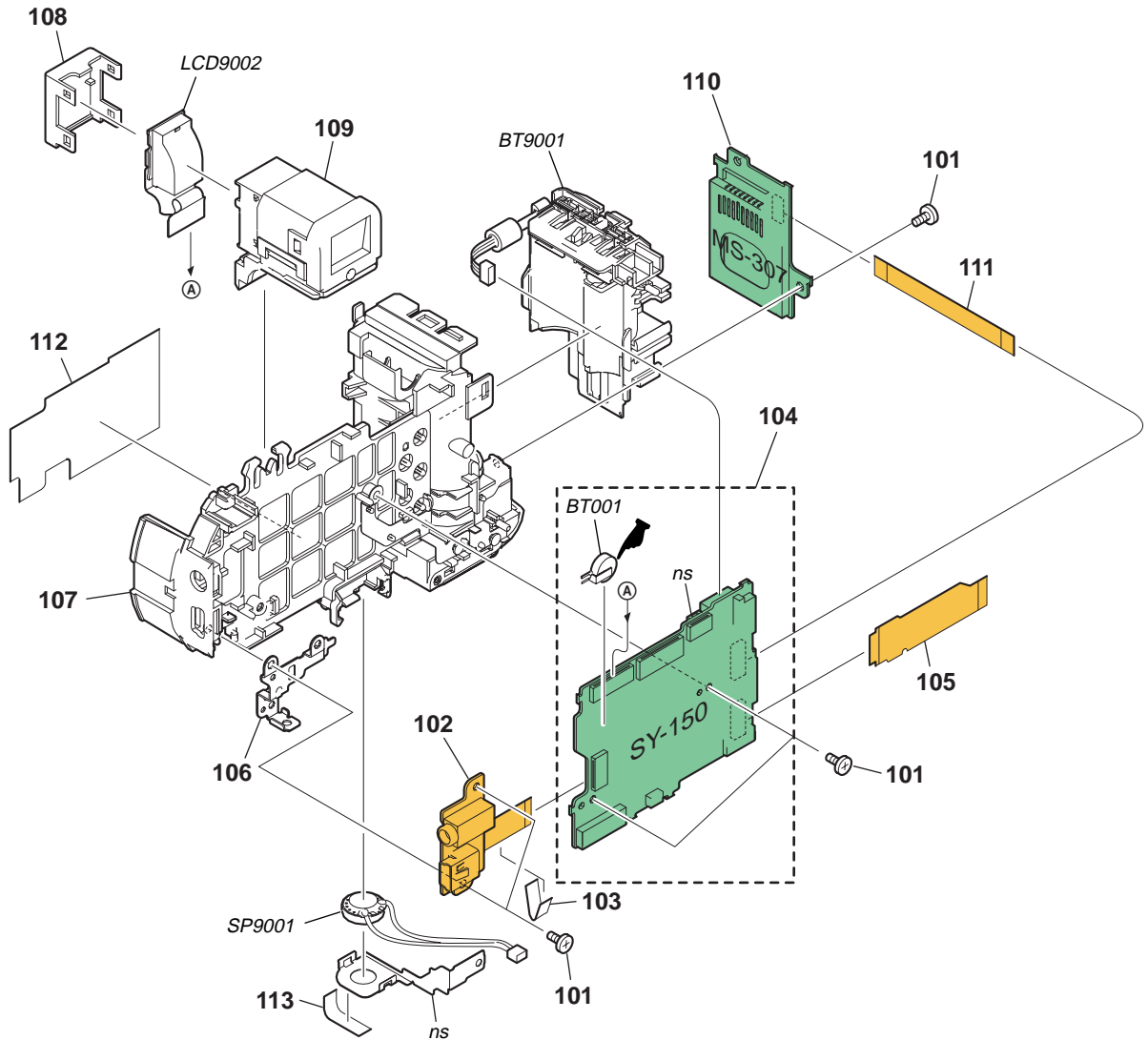

: BT001 (Lithium battery) SY-150 board on the mount position. (See page 4-52)

Ref. No.	Part No.	Description
101	3-080-204-11	SCREW, TAPPING, P2
102	A-1176-915-A	JK-306 FLEXIBLE BOARD
* 103	2-672-564-01	SHEET (JK), RADIATION
104	A-1176-916-A	SY-150 BOARD, COMPLETE (SERVICE) (GP2)
104	A-1176-917-A	SY-150 BOARD, COMPLETE (SERVICE) (GP3)
104	A-1176-918-A	SY-150 BOARD, COMPLETE (SERVICE) (GP4)
105	1-869-227-11	SW-478 FLEXIBLE BOARD
* 106	2-673-306-01	PLATE, JK GROUND
107	X-2108-910-1	HOLDER ASSY, BATTERY
* 108	2-673-337-01	RETAINER, MODULE

Ref. No.	Part No.	Description
109	X-2108-913-1	ASSY, VF
110	A-1176-912-A	MS-307 BOARD, COMPLETE
111	1-831-557-11	FLEXIBLE FLAT CABLE (MS-030)
* 112	2-677-004-01	SHEET (INR), RADIATION
* 113	2-684-446-01	SPACER, SP
△ BT001	1-756-539-21	BATTERY, LITHIUM SECONDARY
* BT9001	1-780-338-11	TERMINAL BOARD, BATTERY
LCD9002	1-802-033-11	LCD MODULE
SP9001	1-826-403-21	LOUDSPEAKER (1.0CM)

CAUTION :
 Danger of explosion if battery is incorrectly replaced.
 Replace only with the same or equivalent type.

5. REPAIR PARTS LIST

5-1-4. LENS SECTION

ns : not supplied

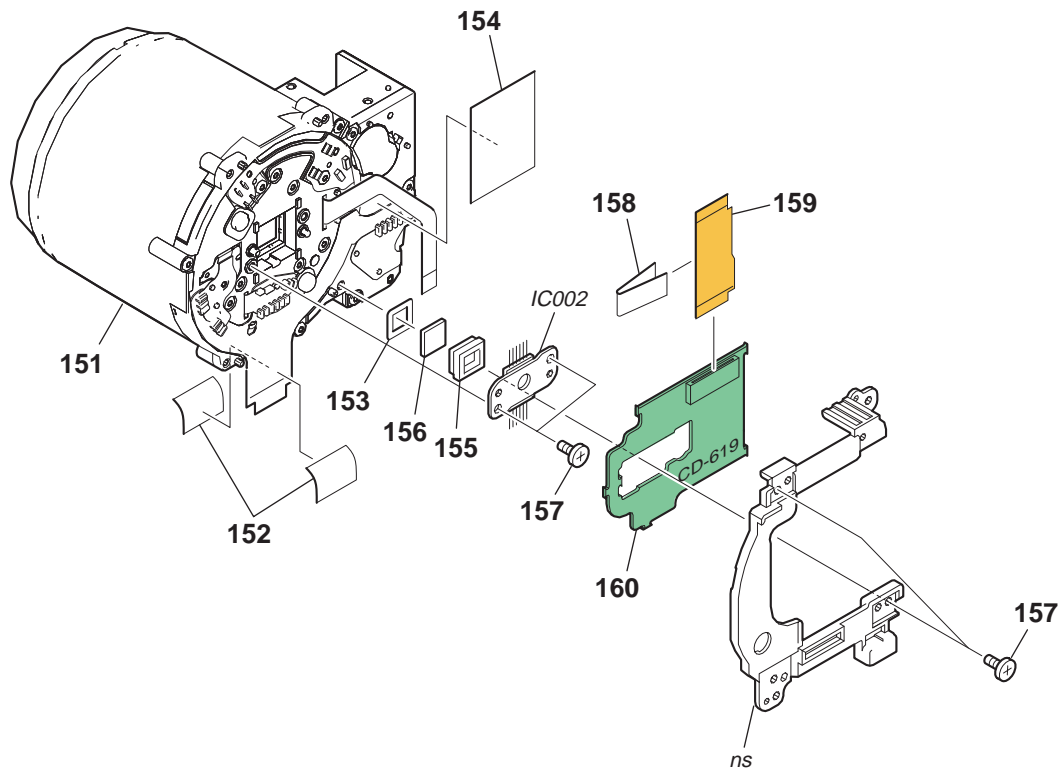

Ref. No.	Part No.	Description	Ref. No.	Part No.	Description
151	A-1177-128-A	OPTICS UNIT (B191A) (SERVICE)	157	2-666-551-21	SCREW, TAPPING, P2
* 152	2-672-563-01	SHEET (LNS), RADIATION	* 158	2-672-562-01	SHEET (CD), RADIATION
153	2-592-693-01	PLATE (T), LIGHT INTERCEPTION	159	1-869-222-11	CD-621 FLEXIBLE BOARD
* 154	2-672-565-01	SHEET (TB), RADIATION	160	A-1176-911-A	CD-619 BOARD, COMPLETE (IC002 is not included in this COMPLETE board.)
155	2-592-605-01	RUBBER (TM), SEAL	IC002	A-1176-034-A	CCD BLOCK ASSY (CCD IMAGER) (IC002 is not included in this COMPLETE board of CD-619.)
156	1-788-338-11	OPTICAL FILTER BLOCK			

Be sure to read "Precautions upon replacing CCD imager" on page 4-3 when changing the CCD imager.

5. REPAIR PARTS LIST

5-1-5. CABINET (FRONT) SECTION

ns : not supplied

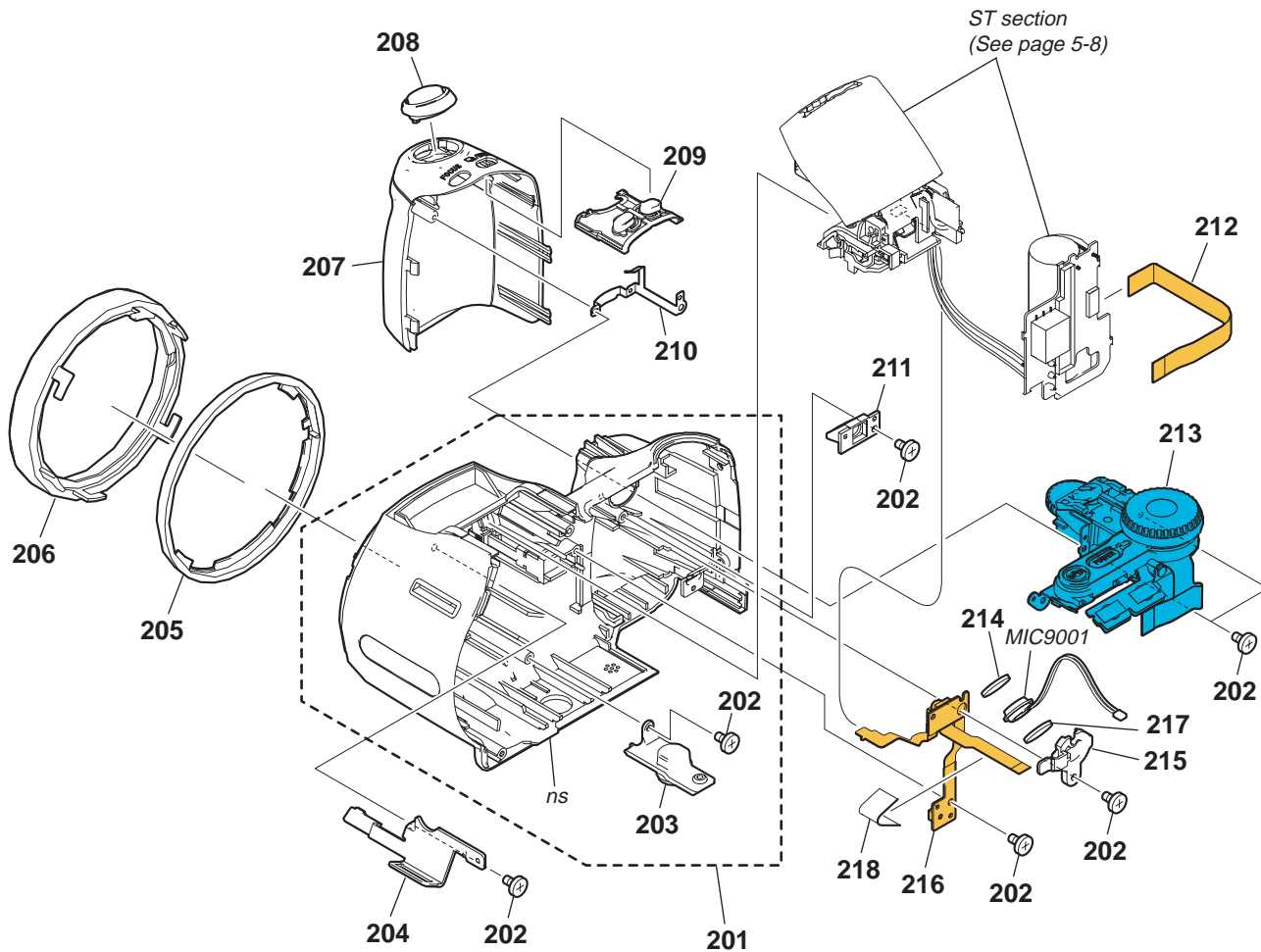

Ref. No.	Part No.	Description
201	X-2108-906-1	CABINET (FRONT) ASSY
202	3-080-204-11	SCREW, TAPPING, P2
203	2-673-230-01	SCREW, TRIPOD
* 204	2-673-328-01	SHEET METAL (R), STRAP
205	2-673-324-01	RING, ORNAMENTAL
206	2-673-323-01	RING, LENS
207	2-673-325-01	GRIP
208	X-2108-325-1	RELEASE ASSY
209	2-673-301-01	BUTTON, FB
* 210	2-673-305-01	PLATE, GRIP GROUND

Ref. No.	Part No.	Description
* 211	2-673-302-01	HOLDER, AF
212	1-831-558-11	FLEXIBLE FLAT CABLE (ST-003)
213	1-479-699-11	SWITCH BLOCK, CONTROL
* 214	2-673-335-01	CUSHION, MICROPHONE
* 215	2-673-334-01	HOLDER, MICROPHONE
216	A-1176-913-A	AF-105 FLEXIBLE BOARD
* 217	2-678-097-01	CUSHION (B), MICROPHONE
* 218	2-672-563-01	SHEET (LNS), RADIATION
MIC9001	1-542-618-21	MICROPHONE

5. REPAIR PARTS LIST

5-1-6. ST SECTION

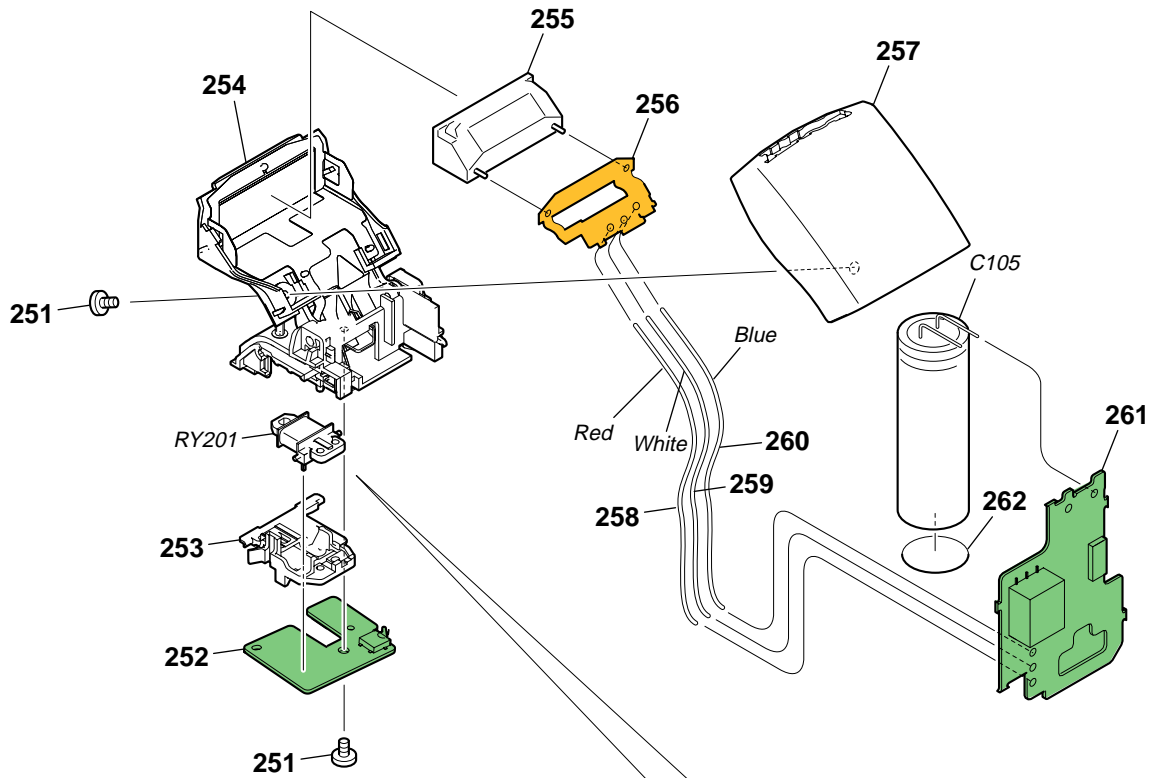

PRECAUTION DURING SOLENOID PLUNGER INSTALLATION

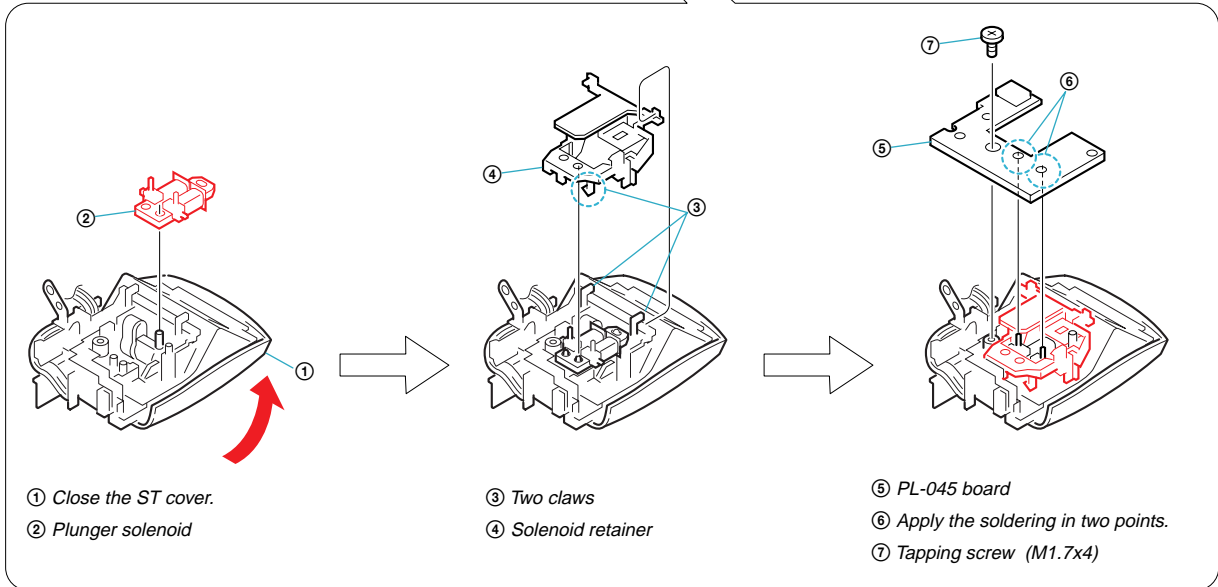

Ref. No.	Part No.	Description
251	3-080-204-11	SCREW, TAPPING, P2
252	A-1176-908-A	PL-045 BOARD, COMPLETE
253	2-629-818-01	RETAINER, SOLENOID
254	X-2108-912-1	BASE ASSY, ST
△ 255	1-479-553-11	FLASH UNIT
256	A-1176-914-A	ST-144 BOARD, COMPLETE
257	2-673-326-01	COVER, ST

Ref. No.	Part No.	Description
258	1-964-411-11	HARNESS (HA-004) (RED)
259	1-964-411-21	HARNESS (HA-004) (WHITE)
260	1-964-411-31	HARNESS (HA-004) (BLUE)
261	A-1176-909-A	ST-142 BOARD, COMPLETE
* 262	2-678-098-01	SHEET, ST ELECTROSTATIC
△ C105	1-112-763-11	CAP, ELECT 320uF 330V
RY201	1-455-038-11	SOLENOID, PLUNGER

5. REPAIR PARTS LIST

Checking supplied accessories.

Make sure that the following accessories are supplied with your camcorder.

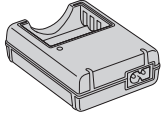

- △ Ni-MH battery charger BC-CS2A/CS2B (1)
(US,CND,JE model)
1-479-378-11
- △ Ni-MH battery charger BC-CS2A/CS2B (1)
(AEP,UK,E,AUS,HK,AR model)
1-479-378-21
- △ Ni-MH battery charger BC-CS2A/CS2B (1)
(KR,CH model)
1-479-378-31

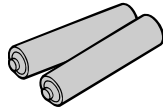

HR6 (size AA) Nickel-Metal
Hydride batteries (2)
(not supplied)



Adaptor ring (1)
2-629-861-01

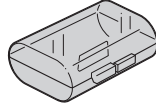

Battery case (1)
3-074-757-01

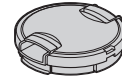

Lens cap (1)
X-2055-960-1

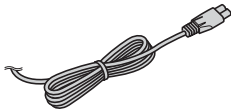

- △ Power cord (Mains lead) (1)
(US,CND model)
1-790-107-51
- △ Power cord (Mains lead) (1)
(AEP,E model)
1-824-910-31
- △ Power cord (Mains lead) (1)
(AUS model)
1-827-945-41
- △ Power cord (Mains lead) (1)
(KR model)
1-823-947-51
- △ Power cord (Mains lead) (1)
(UK model)
1-827-269-22
- △ Power cord (Mains lead) (1)
(HK model)
1-783-374-22
- △ Power cord (Mains lead) (1)
(AR model)
1-783-952-51
- △ Power cord (Mains lead) (1)
(CH model)
1-782-476-41
- △ Power cord (Mains lead) (1)
(JE model)
1-792-549-31

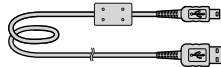

USB cable (1)
1-829-868-41



Lens cap strap (1)
3-979-194-31

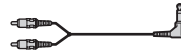

AV cable (1)
1-824-519-11

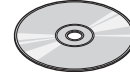

CD-ROM
(Cyber-shot application software) (1)
2-666-673-01

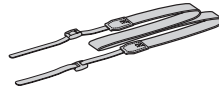

Shoulder strap (1)
2-629-892-01

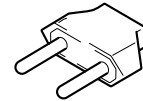

2-pin conversion adaptor (1)
(JE model)
1-569-007-12

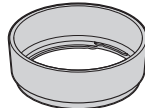

Lens hood (1)
2-629-860-01

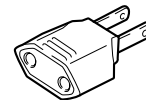

2-pin conversion adaptor (1)
(E model)
1-569-008-12

Other accessories

- | | |
|---|--|
| <p>2-673-164-11 INSTRUCTION (READ THIS FIRST) (ENGLISH)
(US,CND,AEP,UK,E,HK,AUS,JE)</p> <p>2-673-164-21 INSTRUCTION (READ THIS FIRST)
(FRENCH/ITALIAN)(CND,AEP)</p> <p>2-673-164-31 INSTRUCTION (READ THIS FIRST)
(SPANISH/PORTUGUESE)(AEP,E,AR,JE)</p> <p>2-673-164-41 INSTRUCTION (READ THIS FIRST) (GERMAN/DUTCH)
(AEP)</p> <p>2-673-164-51 INSTRUCTION (READ THIS FIRST)
(TRADITIONAL CHINESE/SIMPLIFIED CHINESE)(E,HK,CH,JE)</p> <p>2-673-164-61 INSTRUCTION (READ THIS FIRST) (RUSSIAN)(AEP)</p> <p>2-673-164-71 INSTRUCTION (READ THIS FIRST) (ARABIC/PERSIAN)(E)</p> <p>2-673-164-81 INSTRUCTION (READ THIS FIRST) (KOREAN)(KR,JE)</p> <p>2-673-164-91 INSTRUCTION (READ THIS FIRST) (CZECH/POLISH)
(AEP)</p> <p>2-673-165-11 INSTRUCTION (READ THIS FIRST)
(HUNGARIAN/SLOVAK)(AEP)</p> <p>2-673-165-21 INSTRUCTION (READ THIS FIRST) (SWEDISH/FINNISH)
(AEP)</p> <p>2-673-165-31 INSTRUCTION (READ THIS FIRST)
(NORWEGIAN/DANISH)(AEP)</p> | <p>2-673-166-11 INSTRUCTION (USER'S GUIDE) (ENGLISH)
(US,CND,AEP,UK,E,HK,AUS,JE)</p> <p>2-673-166-21 INSTRUCTION (USER'S GUIDE) (FRENCH/ITALIAN)
(CND,AEP)</p> <p>2-673-166-31 INSTRUCTION (USER'S GUIDE)
(SPANISH/PORTUGUESE)(AEP,E,AR,JE)</p> <p>2-673-166-41 INSTRUCTION (USER'S GUIDE) (GERMAN/DUTCH)(AEP)</p> <p>2-673-166-51 INSTRUCTION (USER'S GUIDE)
(TRADITIONAL CHINESE/SIMPLIFIED CHINESE)(E,HK,CH,JE)</p> <p>2-673-166-61 INSTRUCTION (USER'S GUIDE) (RUSSIAN)(AEP)</p> <p>2-673-166-71 INSTRUCTION (USER'S GUIDE) (ARABIC/PERSIAN)(E)</p> <p>2-673-166-81 INSTRUCTION (USER'S GUIDE) (KOREAN)(KR,JE)</p> <p>2-673-166-91 INSTRUCTION (USER'S GUIDE) (POLISH/CZECH)(AEP)</p> <p>2-673-167-11 INSTRUCTION (USER'S GUIDE) (HUNGARIAN/SLOVAK)
(AEP)</p> <p>2-673-167-21 INSTRUCTION (USER'S GUIDE) (SWEDISH/FINNISH)
(AEP)</p> <p>2-673-167-31 INSTRUCTION (USER'S GUIDE) (NORWEGIAN/DANISH)
(AEP)</p> |
|---|--|

AF-105

CD-619

JK-306

MS-307

PL-045

ST-142

5-2. ELECTRICAL PARTS LIST

Ref. No.	Part No.	Description
	A-1176-913-A	AF-105 FLEXIBLE BOARD, COMPLETE ***** (D001 (AF LED) is not supplied, but this is included in AF-105 flexible board complete.) < DIODE >
D001	Not supplied	DIODE DOR5073 (AF LED) (D001 (AF LED) is not supplied, but this is included in AF-105 flexible board complete.) < SWITCH >
S001	1-762-805-21	SWITCH, PUSH (1 KEY) (LENS COVER OPEN)
	A-1176-911-A	CD-619 BOARD, COMPLETE ***** (IC002 is not included in this COMPLETE board.) < CAPACITOR >
C002	1-164-943-81	CERAMIC CHIP 0.01uF 10% 16V
C004	1-107-826-11	CERAMIC CHIP 0.1uF 10% 16V
C005	1-107-826-11	CERAMIC CHIP 0.1uF 10% 16V
C006	1-107-826-11	CERAMIC CHIP 0.1uF 10% 16V
C007	1-107-826-11	CERAMIC CHIP 0.1uF 10% 16V
		< CONNECTOR >
* CN001	1-816-057-51	CONNECTOR, FPC (ZIF) 39P < FERRITE BEAD >
FB001	1-400-620-21	INDUCTOR, FERRITE BEAD (1005) < IC >
IC001	8-753-230-85	IC CXA3691EN-T9
IC002	A-1176-034-A	CCD BLOCK ASSY (CCD IMAGER) (IC002 is not included in this COMPLETE of CD-619 board.) < TRANSISTOR >
Q001	6-550-119-01	TRANSISTOR DTC144EMT2L < RESISTOR >
R002	1-218-990-81	SHORT CHIP 0
R003	1-218-982-11	RES-CHIP 270K 5% 1/16W
R004	1-218-989-11	RES-CHIP 1M 5% 1/16W
R007	1-218-981-11	RES-CHIP 220K 5% 1/16W
R009	1-218-954-11	RES-CHIP 1.2K 5% 1/16W

A-1176-915-A JK-306 FLEXIBLE BOARD, COMPLETE

< CONNECTOR >

CN001 1-794-962-11 CONNECTOR, SQUARE TYPE (USB 5P)

< JACK >

J001 1-793-620-41 JACK (A/V OUT)

Ref. No.	Part No.	Description
	A-1176-912-A	MS-307 BOARD, COMPLETE ***** < CAPACITOR >
C301	1-100-786-91	TANTAL. CHIP 22uF 20% 6.3V
C302	1-125-777-11	CERAMIC CHIP 0.1uF 10% 10V
		< CONNECTOR >
* CN301	1-816-644-51	FFC/FPC CONNECTOR (LIF) 12P
CN302	1-817-827-11	MEMORY STICK DUO CONNECTOR < FERRITE BEAD >
FB301	1-469-581-21	INDUCTOR, FERRITE BEAD (1005)
FB302	1-469-581-21	INDUCTOR, FERRITE BEAD (1005)
FB303	1-469-581-21	INDUCTOR, FERRITE BEAD (1005)
FB304	1-469-581-21	INDUCTOR, FERRITE BEAD (1005)
		< RESISTOR >
R302	1-218-953-11	RES-CHIP 1K 5% 1/16W
R303	1-218-940-11	RES-CHIP 82 5% 1/16W
R304	1-218-940-11	RES-CHIP 82 5% 1/16W
R305	1-218-990-81	SHORT CHIP 0
R306	1-218-990-81	SHORT CHIP 0
	A-1176-908-A	PL-045 BOARD, COMPLETE ***** (RY201 is not included in this COMPLETE of PL-045 board.) < CAPACITOR >
C201	1-165-908-11	CERAMIC CHIP 1uF 10% 10V
		< CONNECTOR >
* CN201	1-816-654-51	FFC/FPC CONNECTOR (LIF) 6P < DIODE >
D202	8-719-988-61	DIODE 1SS355TE-17
D203	6-500-776-01	DIODE MAZW068H0LS0
		< RELAY >
RY201	1-455-038-11	SOLENOID, PLANGER < SWITCH >
S201	1-786-179-31	SWITCH, PUSH (1KEY)(FLASH POP UP)
	A-1176-909-A	ST-142 BOARD, COMPLETE ***** (C105 is not included in this COMPLETE of ST-142 board.) < CAPACITOR >
C101	1-100-611-91	CERAMIC CHIP 22uF 20% 6.3V
C102	1-100-611-91	CERAMIC CHIP 22uF 20% 6.3V
C103	1-165-908-11	CERAMIC CHIP 1uF 10% 10V
△C105	1-112-763-11	ELECT 320uF 330V
C106	1-100-611-91	CERAMIC CHIP 22uF 20% 6.3V

Be sure to read "Precautions upon replacing CCD imager"
on page 4-3 when changing the CCD imager.

• Refer to page 5-1 for mark △.

Ref. No.	Part No.	Description
		< CONNECTOR >
* CN101	1-816-644-51	FFC/FPC CONNECTOR (LIF) 12P
		< DIODE >
D101	8-719-056-54	DIODE MAZS068008SO
△D102	6-501-096-01	DIODE CRF02 (TE85R)
		< IC >
IC101	6-707-555-01	IC TPS65552RGTR
		< COIL >
L101	1-456-995-22	INDUCTOR 4.7uH
		< TRANSISTOR >
Q101	6-550-891-01	TRANSISTOR GT8G133 (T2LSONY.Q)
		< RESISTOR >
R103	1-243-975-11	METAL CHIP 4.7M 5% 1/16W
R104	1-218-935-11	RES-CHIP 33 5% 1/16W
		< TRANSFORMER >
△T101	1-443-850-21	DC-DC CONVERTER TRANSFORMER
	A-1176-914-A	ST-144 BOARD, COMPLETE *****
		< CAPACITOR >
C002	1-100-758-11	CERAMIC CHIP 0.047uF 10% 250V
C003	1-100-761-21	CERAMIC CHIP 0.01uF 10% 250V
		< DIODE >
D001	6-500-811-01	DIODE RR255L-400TE25
		< COIL >
L001	1-456-193-11	COIL, TRIGGER
		< RESISTOR >
R001	1-216-121-11	RES-CHIP 1M 5% 1/10W
R002	1-216-097-11	RES-CHIP 100K 5% 1/10W
	A-1176-910-A	SW-473 BOARD, COMPLETE *****
		< CAPACITOR >
C402	1-117-919-11	TANTAL. CHIP 10uF 20% 6.3V
C405	1-100-743-91	CERAMIC CHIP 2.2uF 20% 16V
C406	1-127-760-11	CERAMIC CHIP 4.7uF 10% 6.3V
C408	1-100-966-91	CERAMIC CHIP 10uF 20% 10V
C409	1-115-467-11	CERAMIC CHIP 0.22uF 10% 10V
		< CONNECTOR >
* CN401	1-815-333-51	CONNECTOR, FPC (ZIF) 33P
* CN402	1-816-654-51	FFC/FPC CONNECTOR (LIF) 6P
* CN403	1-815-333-51	CONNECTOR, FPC (ZIF) 33P

Ref. No.	Part No.	Description
		< DIODE >
D501	8-719-056-23	DIODE MA2S111-(K8).SO
D502	6-500-776-01	DIODE MAZW068H0LS0
D503	8-719-064-07	DIODE SML-310LTT86 (ACCESS)
		< COIL >
L402	1-400-588-11	INDUCTOR 10uH
L403	1-400-588-11	INDUCTOR 10uH
		< RESISTOR >
R405	1-218-973-11	RES-CHIP 47K 5% 1/16W
R501	1-218-962-11	RES-CHIP 5.6K 5% 1/16W
R502	1-218-970-11	RES-CHIP 27K 5% 1/16W
R503	1-218-962-11	RES-CHIP 5.6K 5% 1/16W
R504	1-218-970-11	RES-CHIP 27K 5% 1/16W
R505	1-208-671-11	METAL CHIP 330 0.5% 1/16W
		< COMPOSITION CIRCUIT BLOCK >
RB501	1-234-376-11	RES, NETWORK 2.2K (1005X4)
RB502	1-234-376-11	RES, NETWORK 2.2K (1005X4)
		< SWITCH >
S501	1-786-157-11	SWITCH, TACTILE (MENU)
S502	1-786-157-11	SWITCH, TACTILE (DISP)
S503	1-786-157-11	SWITCH, TACTILE (LEFT)
S504	1-786-525-31	TACTILE SWITCH (ZOOM W)
S505	1-786-157-11	SWITCH, TACTILE (UP)
S506	1-786-157-11	SWITCH, TACTILE (SET)
S507	1-786-157-11	SWITCH, TACTILE (DOWN)
S508	1-786-525-31	TACTILE SWITCH (ZOOM T)
S509	1-786-157-31	SWITCH, TACTILE (DUST)
S510	1-786-157-11	SWITCH, TACTILE (RIGHT)

SY-150 BOARD, COMPLETE

Electrical parts list of the SY-150 board is not shown.
 Pages from 5-12 to 5-15 are not shown.

• Refer to page 5-1 for mark △.

[Description of main button functions on toolbar of the Adobe Acrobat Reader Ver5.0 (for Windows)]

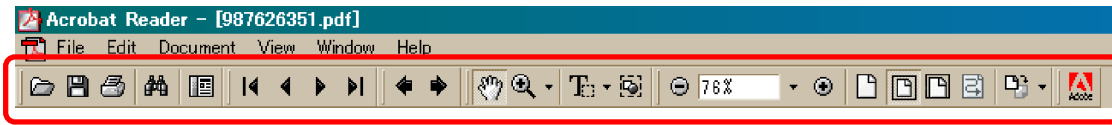

Toolbar



Printing a text

1. Click the Print button .
2. Specify a printer, print range, number of copies, and other options, and then click [OK].

Application of printing:

To set a range to be printed within a page, select the graphic selection tool  and drag on the page to enclose a range to be printed, and then click the Print button.

Reversing the screens displayed once

- To reverse the previous screens (operation) one by one, click the .
- To advance the reversed screens (operation) one by one, click the .

Application to the Service Manual:

This function allows you to go and back between circuit diagram and printed circuit board diagram, and accordingly it will be convenient for the voltage check.

Finding a text

1. Click the Find button .
2. Enter a character string to be found into a text box, and click the [Find]. (Specify the find options as necessary)

Application to the Service Manual:

To execute “find” from current page toward the previous pages, select the check box “Find Backwards” and then click the “Find”.

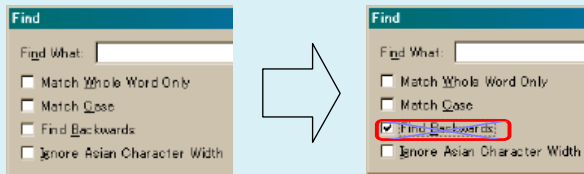





3. Open the find dialog box again, and click the [Find Again] and you can find the matched character strings displayed next. (Character strings entered previously are displayed as they are in the text box.)

Application to the Service Manual:

The parts on the drawing pages (block diagrams, circuit diagrams, printed circuit boards) and parts list pages in a text can be found using this find function. For example, find a Ref. No. of IC on the block diagram, and click the [Find Again] continuously, so that you can move to the Ref. No. of IC on the circuit diagram or printed circuit board diagram successively.

Note: The find function may not be applied to the Service Manual depending on the date of issue.

Moving with link

1. Select either palm tool , zoom tool , text selection tool , or graphic selection tool .
2. Place the pointer in the position in a text where the link exists (such as a button on cover and the table of contents page, or blue characters on the removal flowchart page or drawing page), and the pointer will change to the forefinger form .
3. Then, click the link. (You will go to the link destination.)

Moving with bookmark:

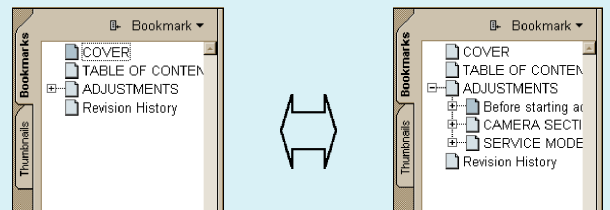

Click an item (text) on the bookmark pallet. and you can move to the link destination. Also, clicking  can display the hidden items.

(To go back to original state, click )



Zooming or rotating the screen display

“Zoom in/out”

- Click the triangle button in the zoom control box to select the display magnification. Or, you may click  or  for zooming in or out.

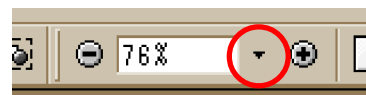





“Rotate”

- Click rotate tool , and the page then rotates 90 degrees each.

Application to the Service Manual:

The printed circuit board diagram you see now can be changed to the same direction as the set.

Switching a page

- To move to the first page, click the .
- To move to the last page, click the .
- To move to the previous page, click the .
- To move to the next page, click the .

