

CDX-GT20W/GT200/GT200E/ GT200S/GT250S

SERVICE MANUAL

Ver. 1.0 2005. 09

US Model
Canadian Model
CDX-GT20W/GT200
AEP Model
UK Model
CDX-GT200/GT200E/GT200S
E Model
CDX-GT250S



- The tuner and CD sections have no adjustments.

AUDIO POWER SPECIFICATIONS (US MODEL)

POWER OUTPUT AND TOTAL HARMONIC DISTORTION
23.2 watts per channel minimum continuous average power into
4 ohms, 4 channels driven from 20 Hz to 20 kHz with no more
than 5% total harmonic distortion.

Model Name Using Similar Mechanism	NEW
CD Drive Mechanism Type	MG-611WA-186/C
Optical Pick-up Name	KSS1000E

CD Player section

Signal-to-noise ratio: 120 dB
Frequency response: 10 – 20,000 Hz
Wow and flutter: Below measurable limit

Tuner section

FM

Tuning range: CDX-GT20W/GT200 (US, Canadian):
87.5 – 107.9 MHz
CDX-GT200 (AEP, UK)/GT200E/GT200S:
87.5 – 108.0 MHz
CDX-GT250S:
87.5 – 108.0 MHz (at 50 kHz step)
87.5 – 107.9 MHz (at 200 kHz step)

FM tuning interval (CDX-GT250S only):
50 kHz/200 kHz switchable

Antenna terminal: External antenna connector
Intermediate frequency: 10.7 MHz/450 kHz
Usable sensitivity: 9 dBf
Selectivity: 75 dB at 400 kHz
Signal-to-noise ratio: 67 dB (stereo), 69 dB (mono)
Harmonic distortion at 1 kHz:
0.5 % (stereo), 0.3 % (mono)
Separation: 35 dB at 1 kHz
Frequency response: 30 – 15,000 Hz

AM (CDX-GT20W/GT200 (US, Canadian)/GT250S)

Tuning range: CDX-GT20W/GT200 (US, Canadian):
530 – 1,710 kHz
CDX-GT250S:
531 – 1,602 kHz (at 9 kHz step)
530 – 1,710 kHz (at 10 kHz step)

SPECIFICATIONS

AM tuning interval (CDX-GT250S only):

9 kHz/10 kHz switchable
Antenna terminal: External antenna connector
Intermediate frequency: 10.7 MHz/450 kHz
Sensitivity: 30 µV

MW/LW (CDX-GT200 (AEP, UK)/GT200E/GT200S)

Tuning range: MW: 531 – 1,602 kHz
LW: 153 – 279 kHz
Aerial terminal: External aerial connector
Intermediate frequency: 10.7 MHz/450 kHz
Sensitivity: MW: 30 µV, LW: 40 µV

Power amplifier section

Outputs: Speaker outputs (sure seal connectors)
Speaker impedance: 4 – 8 ohms
Maximum power output: CDX-GT20W/GT200 (US, Canadian)/GT250S:
52 W × 4 (at 4 ohms)
CDX-GT200 (AEP, UK)/GT200E/GT200S:
50 W × 4 (at 4 ohms)

– Continued on next page –

FM/AM COMPACT DISC PLAYER
CDX-GT20W/GT200: US, CND/GT250S

FM/MW/LW COMPACT DISC PLAYER
CDX-GT200: AEP, UK/GT200E/GT200S

9-879-862-01
2005I04-1
© 2005. 09

Sony Corporation
e Vehicle Group
Published by Sony Engineering Corporation

SONY®

CDX-GT20W/GT200/GT200E/GT200S/GT250S

General

Outputs:	Audio outputs terminal (sub/rear switchable) Power antenna relay control terminal Power amplifier control terminal
Inputs:	Antenna input terminal AUX input jack (stereo mini jack)
Tone controls:	Low: ± 10 dB at 60 Hz (XPLOD) Mid: ± 10 dB at 1 kHz (XPLOD) High: ± 10 dB at 10 kHz (XPLOD)
Power requirements:	12 V DC car battery (negative ground)
Dimensions:	Approx. 178 × 50 × 179 mm (7 1/8 × 2 × 7 1/8 in) (w/h/d)
Mounting dimensions:	Approx. 182 × 53 × 161 mm (7 1/4 × 2 1/8 × 6 3/8 in) (w/h/d)
Mass:	Approx. 1.2 kg (2 lb 11 oz)
Supplied accessories:	Parts for installation and connections (1 set) Card remote commander: RM-X151 (CDX-GT20W/ GT200/GT250S)

Design and specifications are subject to change without notice.

SERVICE NOTES

CAUTION

Use of controls or adjustments or performance of procedures other than those specified herein may result in hazardous radiation exposure.

Case of CDX-GT200: AEP, UK/GT200E/GT200S/GT250S

This compact disc player is classified as a CLASS 1 LASER product. The CLASS 1 LASER PRODUCT label is located on the exterior.

**CLASS 1
LASER PRODUCT**

This label is located on the bottom of the chassis.

NOTES ON HANDLING THE OPTICAL PICK-UP BLOCK OR BASE UNIT

The laser diode in the optical pick-up block may suffer electrostatic breakdown because of the potential difference generated by the charged electrostatic load, etc. on clothing and the human body.

During repair, pay attention to electrostatic breakdown and also use the procedure in the printed matter which is included in the repair parts.

The flexible board is easily damaged and should be handled with care.

NOTES ON LASER DIODE EMISSION CHECK

The laser beam on this model is concentrated so as to be focused on the disc reflective surface by the objective lens in the optical pick-up block. Therefore, when checking the laser diode emission, observe from more than 30 cm away from the objective lens.

Notes on Chip Component Replacement

- Never reuse a disconnected chip component.
- Notice that the minus side of a tantalum capacitor may be damaged by heat.

If the optical pick-up block is defective, please replace the whole optical pick-up block.

Never turn the semi-fixed resistor located at the side of optical pick-up block.

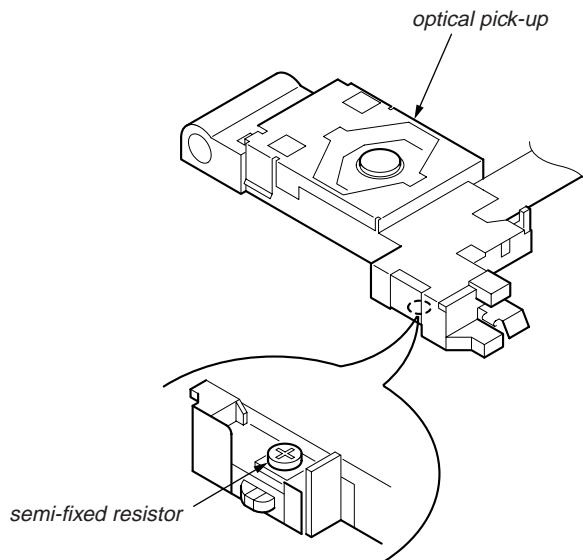

TEST DISCS

This set can playback CD-R and CD-ROM discs. The following test discs should be used to check the capability:

- CD-R test disc TCD-R082LMT (Part No. J-2502-063-1)
- CD-RW test disc TCD-W082L (Part No. J-2502-063-2)

SAFETY-RELATED COMPONENT WARNING!!







COMPONENTS IDENTIFIED BY MARK \triangle OR DOTTED LINE WITH MARK \triangle ON THE SCHEMATIC DIAGRAMS AND IN THE PARTS LIST ARE CRITICAL TO SAFE OPERATION. REPLACE THESE COMPONENTS WITH SONY PARTS WHOSE PART NUMBERS APPEAR AS SHOWN IN THIS MANUAL OR IN SUPPLEMENTS PUBLISHED BY SONY.

ATTENTION AU COMPOSANT AYANT RAPPORT À LA SÉCURITÉ!!

LES COMPOSANTS IDENTIFIÉS PAR UNE MARQUE \triangle SUR LES DIAGRAMMES SCHÉMATIQUES ET LA LISTE DES PIÈCES SONT CRITIQUES POUR LA SÉCURITÉ DE FONCTIONNEMENT. NE REMPLACER CES COMPOSANTS QUE PAR DES PIÈCES SONY DONT LES NUMÉROS SONT DONNÉS DANS CE MANUEL OU DANS LES SUPPLÉMENTS PUBLIÉS PAR SONY.

• **CD playback**

You can play CD-DA (also containing CD TEXT*), CD-R/CD-RW (MP3/WMA files also containing Multi Session and ATRAC CD (ATRAC3 and ATRAC3plus format).

Type of discs	Label on the disc
CD-DA	 
MP3 WMA ATRAC CD	   

* A CD TEXT disc is a CD-DA that includes information such as disc, artist and track name.

EXTENSION CABLE AND SERVICE POSITION

When repairing or servicing this set, connect the jig (extension cable) as shown below.

- Connect the MAIN board (CNP301) and the SERVO board (CN2) with the extension cable (Part No. J-2502-076-1).

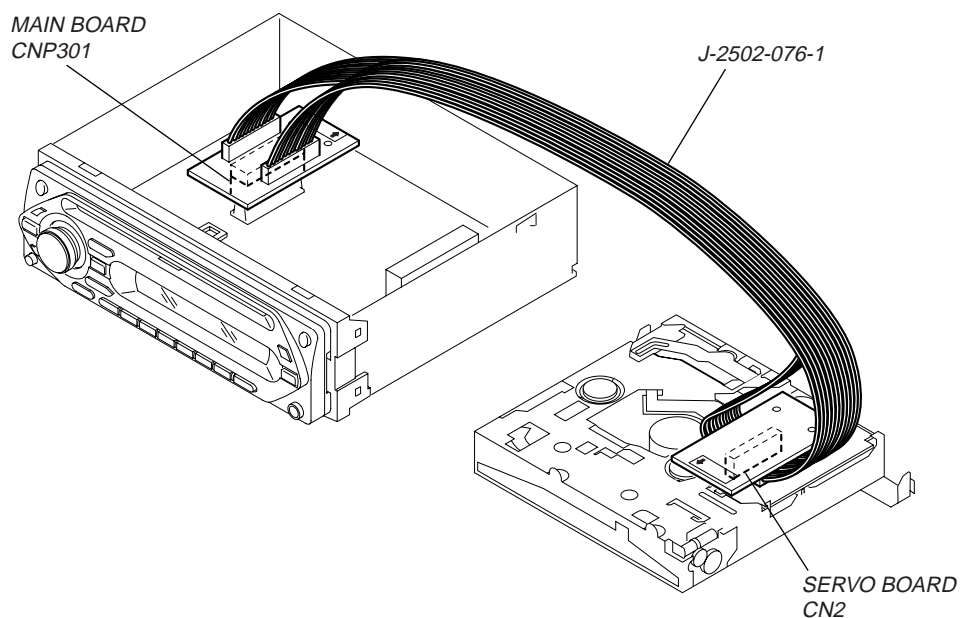

• **UNLEADED SOLDER**

Boards requiring use of unleaded solder are printed with the lead free mark (LF) indicating the solder contains no lead. (Caution: Some printed circuit boards may not come printed with the lead free mark due to their particular size.)

LF : LEAD FREE MARK

Unleaded solder has the following characteristics.

- Unleaded solder melts at a temperature about 40°C higher than ordinary solder. Ordinary soldering irons can be used but the iron tip has to be applied to the solder joint for a slightly longer time. Soldering irons using a temperature regulator should be set to about 350°C. Caution: The printed pattern (copper foil) may peel away if the heated tip is applied for too long, so be careful!
- Strong viscosity Unleaded solder is more viscous (sticky, less prone to flow) than ordinary solder so use caution not to let solder bridges occur such as on IC pins, etc.
- Usable with ordinary solder It is best to use only unleaded solder but unleaded solder may also be added to ordinary solder.

TABLE OF CONTENTS

1. GENERAL

Location of controls and basic operations 5
 Connections 7

2. DISASSEMBLY

2-1. Sub Panel Assy 10
 2-2. CD Mechanism Block 10
 2-3. Main Board 11
 2-4. Chassis (T) Sub Assy 11
 2-5. Roller Arm Assy 12
 2-6. Chassis (OP) Assy 12
 2-7. Optical Pick-up 13
 2-8. SL Motor Assy (M902) 13
 2-9. LE Motor Assy (M903) 14
 2-10. Servo Board 14

3. DIAGRAMS

3-1. Block Diagram – CD Section – 15
 3-2. Block Diagram – Main Section – 16
 3-3. Block Diagram – Display Section – 17
 3-4. Circuit Boards Location 17
 3-5. Printed Wiring Boards – CD Mechanism Section – 19
 3-6. Schematic Diagram – CD Mechanism Section (1/2) – 20
 3-7. Schematic Diagram – CD Mechanism Section (2/2) – 21
 3-8. Printed Wiring Board – Main Section – 22
 3-9. Schematic Diagram – Main Section (1/3) – 23
 3-10. Schematic Diagram – Main Section (2/3) – 24
 3-11. Schematic Diagram – Main Section (3/3) – 25
 3-12. Printed Wiring Boards – Key Section – 26
 3-13. Schematic Diagram – Key Section – 27

4. EXPLODED VIEWS

4-1. Main Section 34
 4-2. Front Panel Section 35
 4-3. CD Mechanism Section (1) (MG-611WA-186/C) 36
 4-4. CD Mechanism Section (2) (MG-611WA-186/C) 37
 4-5. CD Mechanism Section (3) (MG-611WA-186/C) 38
 4-6. CD Mechanism Section (4) (MG-611WA-186/C) 39

5. ELECTRICAL PARTS LIST 40

CDX-GT20W/GT200/GT200E/GT200S/GT250S

SECTION 1

GENERAL

This section is extracted from instruction manual.

• CDX-GT20W/GT200: US, Canadian

Location of controls and basic operations

Main unit

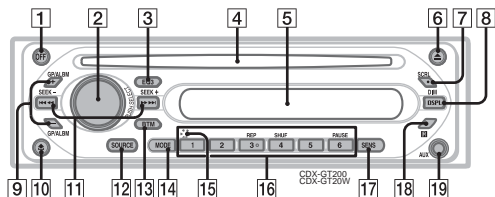

Card remote commander RM-X151 (CDX-GT200 only)

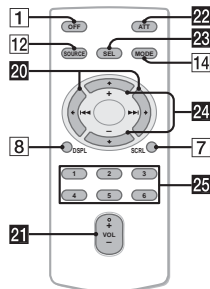

Refer to the pages listed for details.

- 1 **OFF button**
To power off; stop the source.
- 2 **Volume control dial/select button 9**
To adjust volume (rotate); select setup items (press and rotate).
- 3 **EQ3 (equalizer) button 9**
To select an equalizer type (XPLOD, VOCAL, CLUB, JAZZ, NEW AGE, ROCK, CUSTOM or OFF).
- 4 **Disc slot**
To insert the disc (label side up), playback starts.
- 5 **Display window**
- 6 **▲ (eject) button**
To eject the disc.
- 7 **SCRL (scroll) button 8**
To scroll the display item.
- 8 **DSPL (display)/DIM (dimmer) button 4, 8**
To change display items (press); change the display brightness (press and hold).
- 9 **GP*/ALBM*2 +/- buttons**
To skip groups/albums (press); skip groups/albums continuously (press and hold).
- 10 **⏏ (front panel release) button 4**

11 SEEK -/+ buttons

CD:
To skip tracks (press); skip tracks continuously (press, then press again within about 1 second and hold); reverse/fast-forward a track (press and hold).
Radio:
To tune in stations automatically (press); find a station manually (press and hold).

12 SOURCE button

To power on; change the source (Radio/CD/AUX).

13 BTM button 8

To start the BTM function (press and hold).

14 MODE button 8

To select the radio band (FM/AM).

15 RESET button (located behind the front panel) 4

16 Number buttons

CD:
③: REP 8
④: SHUF 8
⑥: PAUSE
To pause playback. To cancel, press again.

Radio:
To receive stored stations (press); store stations (press and hold).

17 SENS button

To improve weak reception: LOCAL/MONO.

18 Receptor for the card remote commander 10

19 AUX input jack 10

To connect a portable audio device.

The following buttons on the card remote commander have also different buttons/functions from the unit.

20 ◀ (◀◀) / ▶ (▶▶) buttons

CD:
To control CD/Radio, the same as (SEEK) +/- on the unit.

21 VOL (volume) +/- button

To adjust volume.

22 ATT (attenuate) button

To attenuate the sound. To cancel, press again.

23 SEL (select) button

To select items.

24 ▲ (+) / ▼ (-) buttons

To control CD, the same as (GP/ALBM) +/- on the unit.

25 Number buttons

To receive stored stations (press); store stations (press and hold).

*1 When an ATRAC CD is played.
*2 When an MP3/WMA is played.

Note
If the unit is turned off and the display disappears, it cannot be operated with the card remote commander unless (SOURCE) on the unit is pressed, or a disc is inserted to activate the unit first.

Tip
For details on how to replace the battery, see "Replacing the lithium battery" on page 12.

• CDX-GT200: AEP, UK/GT200S

Location of controls and basic operations

Main unit

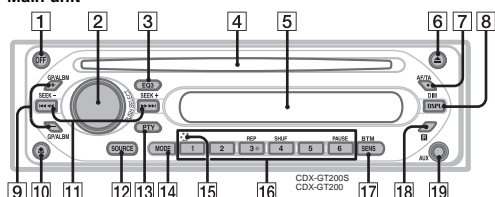

Refer to the pages listed for details.

- 1 **OFF button**
To power off; stop the source.
- 2 **Volume control dial/select button 9**
To adjust volume (rotate); select setup items (press and rotate).
- 3 **EQ3 (equalizer) button 9**
To select an equalizer type (XPLOD, VOCAL, CLUB, JAZZ, NEW AGE, ROCK, CUSTOM or OFF).
- 4 **Disc slot**
To insert the disc (label side up), playback starts.
- 5 **Display window**
- 6 **▲ (eject) button**
To eject the disc.
- 7 **AF (Alternative Frequencies)/TA (Traffic Announcement) button 7**
To set AF and TA/TP in RDS.
- 8 **DSPL (display)/DIM (dimmer) button 4, 6**
To change display items (press); change the display brightness (press and hold).
- 9 **GP*/ALBM*2 +/- buttons**
To skip groups/albums (press); skip groups/albums continuously (press and hold).
- 10 **⏏ (front panel release) button 4**
- 11 **SEEK -/+ buttons**
CD:
To skip tracks (press); skip tracks continuously (press, then press again within about 1 second and hold); reverse/fast-forward a track (press and hold).
- 12 **SOURCE button**
To power on; change the source (Radio/CD/AUX).
- 13 **PTY (Programme Type) button 8**
To select PTY in RDS.
- 14 **MODE button 6**
To select the radio band (FM/MW/LW).
- 15 **RESET button (located behind the front panel) 4**
- 16 **Number buttons**
CD:
③: REP 6
④: SHUF 6
⑥: PAUSE
To pause playback. To cancel, press again.
Radio:
To receive stored stations (press); store stations (press and hold).
- 17 **SENS/BTM button**
To improve weak reception: LOCAL/MONO (press); start the BTM function (press and hold).
- 18 **Receptor for the card remote commander 10**
- 19 **AUX input jack 10**
To connect a portable audio device.
*1 When an ATRAC CD is played.
*2 When an MP3/WMA is played.

• CDX-GT200E

Location of controls and basic operations

Main unit

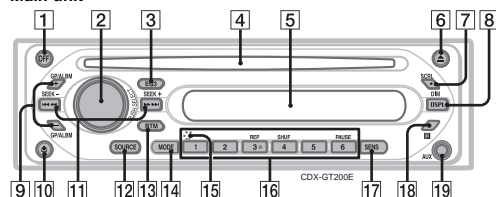

Refer to the pages listed for details.

- 1 **OFF button**
To power off; stop the source.
- 2 **Volume control dial/select button 7**
To adjust volume (rotate); select setup items (press and rotate).
- 3 **EQ3 (equalizer) button 7**
To select an equalizer type (XPLOD, VOCAL, CLUB, JAZZ, NEW AGE, ROCK, CUSTOM or OFF).
- 4 **Disc slot**
To insert the disc (label side up), playback starts.
- 5 **Display window**
- 6 **▲ (eject) button**
To eject the disc.
- 7 **SCRL (scroll) button 6**
To scroll the display item.
- 8 **DSPL (display)/DIM (dimmer) button 4, 6**
To change display items (press); change the display brightness (press and hold).
- 9 **GP*/ALBM*2 +/- buttons**
To skip groups/albums (press); skip groups/albums continuously (press and hold).
- 10 **⏏ (front panel release) button 4**
- 11 **SEEK -/+ buttons**
CD:
To skip tracks (press); skip tracks continuously (press, then press again within about 1 second and hold); reverse/fast-forward a track (press and hold).
- 12 **SOURCE button**
To power on; change the source (Radio/CD/AUX).
- 13 **BTM button 6**
To start the BTM function (press and hold).
- 14 **MODE button 6**
To select the radio band (FM/MW/LW).
- 15 **RESET button (located behind the front panel) 4**
- 16 **Number buttons**
CD:
③: REP 6
④: SHUF 6
⑥: PAUSE
To pause playback. To cancel, press again.
Radio:
To receive stored stations (press); store stations (press and hold).
- 17 **SENS button**
To improve weak reception: LOCAL/MONO.
- 18 **Receptor for the card remote commander 8**
- 19 **AUX input jack 8**
To connect a portable audio device.
*1 When an ATRAC CD is played.
*2 When an MP3/WMA is played.

• CDX-GT250S

Location of controls and basic operations

Main unit

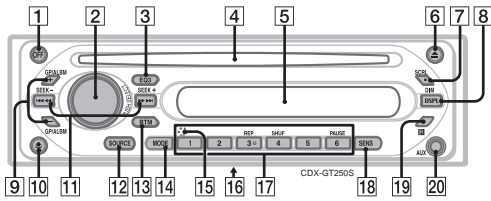

Card remote commander RM-X151

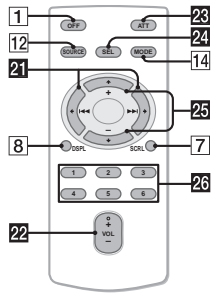

Refer to the pages listed for details. The corresponding buttons on the card remote commander control the same functions as those on the unit.

- 1 **OFF button**
To power off; stop the source.
- 2 **Volume control dial/select button 9**
To adjust volume (rotate); select setup items (press and rotate).
- 3 **EQ3 (equalizer) button 9**
To select an equalizer type (XPLOD, VOCAL, CLUB, JAZZ, NEW AGE, ROCK, CUSTOM or OFF).
- 4 **Disc slot**
To insert the disc (label side up), playback starts.
- 5 **Display window**
- 6 **(eject) button**
To eject the disc.
- 7 **SCRL (scroll) button 8**
To scroll the display item.
- 8 **DSPL (display)/DIM (dimmer) button 4, 8**
To change display items (press); change the display brightness (press and hold).
- 9 **GP*/ALBM*2 -/+ buttons**
To skip groups/albums (press); skip groups/albums continuously (press and hold).
- 10 **(front panel release) button 4**

11 SEEK +/- buttons

CD:
To skip tracks (press); skip tracks continuously (press, then press again within about 1 second and hold); reverse/fast-forward a track (press and hold).
Radio:
To tune in stations automatically (press); find a station manually (press and hold).

12 SOURCE button

To power on; change the source (Radio/CD/AUX).

13 BTM button 8

To start the BTM function (press and hold).

14 MODE button 8

To select the radio band (FM/AM).

15 RESET button (located behind the front panel) 4

16 Frequency select switch (located on the bottom of the unit)

See "Frequency select switch" in the supplied installation/connections manual.

17 Number buttons

CD:
③: **REP 8**
④: **SHUF 8**
⑥: **PAUSE 8**
To pause playback. To cancel, press again.
Radio:
To receive stored stations (press); store stations (press and hold).

18 SENS button

To improve weak reception: LOCAL/MONO.

19 Receptor for the card remote commander

20 AUX input jack 10

To connect a portable audio device.

The following buttons on the card remote commander have also different buttons/functions from the unit.

21 (◀◀) (▶▶) buttons

To control CD/Radio, the same as **(SEEK -/+)** on the unit.

22 VOL (volume) +/- button

To adjust volume.

23 ATT (attenuate) button

To attenuate the sound. To cancel, press again.

24 SEL (select) button

To select items.

25 (+) (-) buttons

To control CD, the same as **(GP/ALBM -/+)** on the unit.

26 Number buttons

To receive stored stations (press); store stations (press and hold).

*1 When an ATRAC CD is played.

*2 When an MP3/WMA is played.

Note

If the unit is turned off and the display disappears, it cannot be operated with the card remote commander unless **(SOURCE)** on the unit is pressed, or a disc is inserted to activate the unit first.

Tip

For details on how to replace the battery, see "Replacing the lithium battery of the card remote commander" on page 12.

• CONNECTIONS
 • CDX-GT20W/GT200: US, Canadian/GT250S

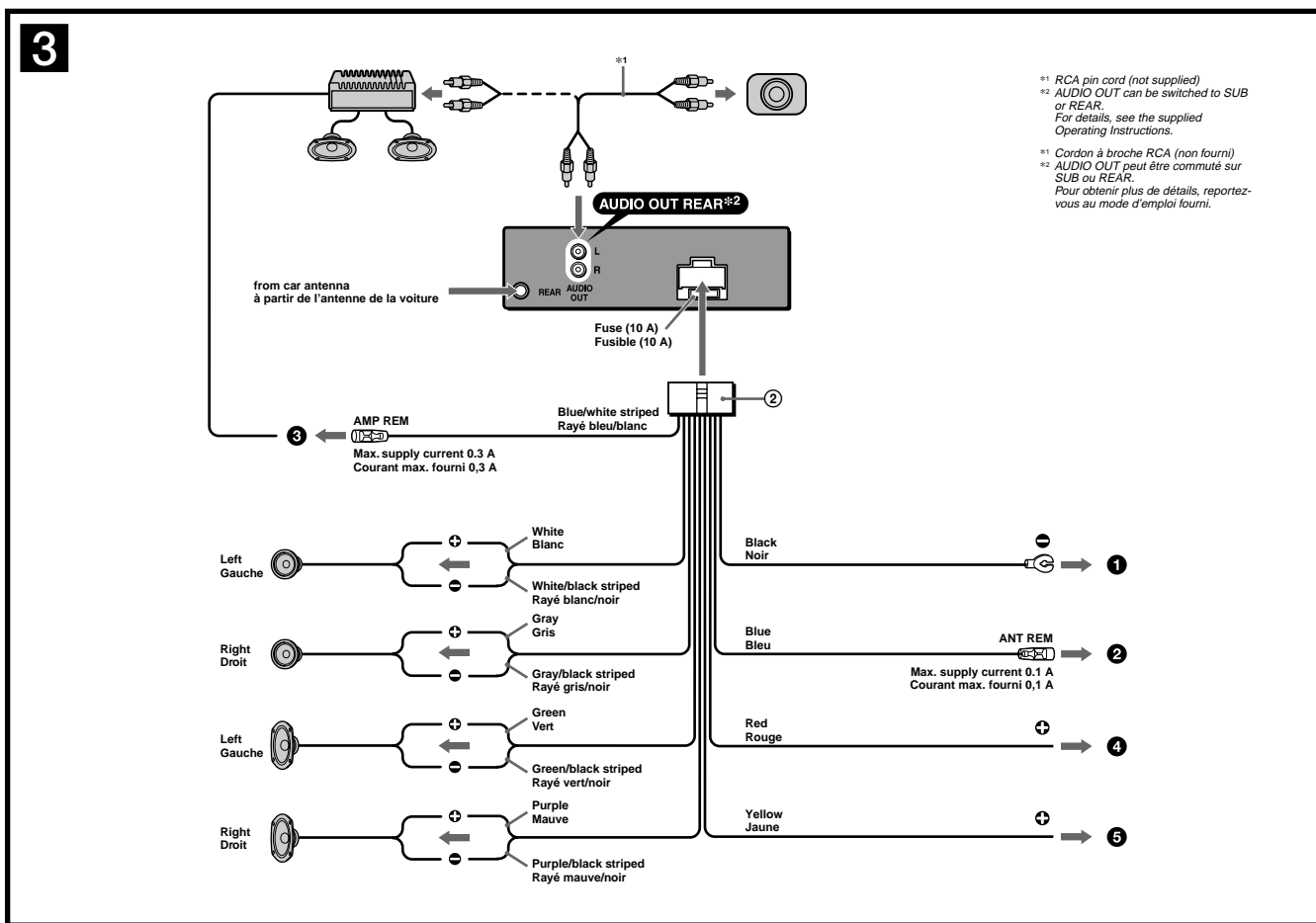

Connection diagram 3

- 1 To a metal surface of the car
 First connect the black ground lead, then connect the yellow and red power input leads.
- 2 To the power antenna control lead or power supply lead of antenna booster amplifier
 Notes
 • It is not necessary to connect this lead if there is no power antenna or antenna booster, or with a manually-operated telescopic antenna.
 • When your car has a built-in FM/AM antenna in the rear/side glass, see "Notes on the control and power supply leads."
- 3 To AMP REMOTE IN of an optional power amplifier
 This connection is only for amplifiers. Connecting any other system may damage the unit.
- 4 To the +12V power terminal which is energized in the accessory position of the ignition key switch
 Notes
 • If there is no accessory position, connect to the +12 V power (battery) terminal which is energized at all times. Be sure to connect the black ground lead to a metal surface of the car first.
 • When your car has a built-in FM/AM antenna in the rear/side glass, see "Notes on the control and power supply leads."
- 5 To the +12V power terminal which is energized at all times
 Be sure to connect the black ground lead to a metal surface of the car first.
 Notes on the control and power supply leads
 • The power antenna control lead (blue) supplies +12 V DC when you turn on the tuner.
 • When your car has built-in FM/AM antenna in the rear/side glass, connect the power antenna control lead (blue) or the accessory power input lead (red) to the power terminal of the existing antenna booster. For details, consult your dealer.
 • A power antenna without a relay box cannot be used with this unit.
 Memory hold connection
 When the yellow power input lead is connected, power will always be supplied to the memory circuit even when the ignition switch is turned off.
 Notes on speaker connection
 • Before connecting the speakers, turn the unit off.
 • Use speakers with an impedance of 4 to 8 ohms, and with adequate power handling capacities to avoid its damage.
 • Do not connect the speaker terminals to the car chassis, or connect the terminals of the right speakers with those of the left speaker.
 • Do not connect the ground lead of this unit to the negative (-) terminal of the speaker.
 • Do not attempt to connect the speakers in parallel.
 • Connect only passive speakers. Connecting active speakers (with built-in amplifiers) to the speaker terminals may damage the unit.
 • To avoid a malfunction, do not use the built-in speaker leads installed in your car if the unit shares a common negative (-) lead for the right and left speakers.
 • Do not connect the unit's speaker leads to each other.
 Note on connection
 If speaker and amplifier are not connected correctly, "FAILURE" appears in the display. In this case, make sure the speaker and amplifier are connected correctly.

Schéma de raccordement 3

- 1 À un point métallique de la voiture
 Branchez d'abord le câble de mise à la masse noir et, ensuite, les câbles d'entrée d'alimentation jaune et rouge.
- 2 Vers le câble de commande d'antenne électrique ou le câble d'alimentation de l'amplificateur d'antenne
 Remarques
 • Il n'est pas nécessaire de raccorder ce câble s'il n'y a pas d'antenne électrique ni d'amplificateur d'antenne, ou avec une antenne télescopique manuelle.
 • Si votre voiture est équipée d'une antenne FM/AM intégrée dans la vitre arrière/latérale, voir « Remarques sur les câbles de commande et d'alimentation ».
- 3 Au niveau de AMP REMOTE IN de l'amplificateur de puissance en option
 Ce raccordement s'applique uniquement aux amplificateurs. Le branchement de tout autre système risque d'endommager l'appareil.
- 4 À la borne +12 V qui est alimentée quand la clé de contact est sur la position accessoires
 Remarques
 • S'il n'y a pas de position accessoires, raccordez la borne d'alimentation (batterie) +12 V qui est alimentée en permanence.
 Raccordez d'abord le câble de mise à la masse noir à un point métallique du véhicule.
 • Si votre voiture est équipée d'une antenne FM/AM intégrée dans la vitre arrière/latérale, voir « Remarques sur les câbles de commande et d'alimentation ».
- 5 À la borne +12 V qui est alimentée en permanence
 Raccordez d'abord le câble de mise à la masse noir à un point métallique du véhicule.
 Remarques sur les câbles de commande et d'alimentation
 • Le câble de commande d'antenne électrique (bleu) fournit une alimentation de +12 V CC lorsque vous mettez la radio sous tension.
 • Lorsque votre voiture est équipée d'une antenne FM/AM intégrée dans la vitre arrière/latérale, raccordez le câble de commande d'antenne (bleu) ou l'entrée d'alimentation des accessoires (rouge) à la borne d'alimentation de l'amplificateur d'antenne existant. Pour plus de détails, consultez votre détaillant.
 • Une antenne électrique sans boîtier de relais ne peut pas être utilisée avec cet appareil.
 Raccordement pour la conservation de la mémoire
 Lorsque le câble d'entrée d'alimentation jaune est raccordé, le circuit de la mémoire est alimenté en permanence même si la clé de contact est sur la position d'arrêt.
 Remarques sur le raccordement des haut-parleurs
 • Avant de raccorder les haut-parleurs, mettez l'appareil hors tension.
 • Utilisez des haut-parleurs ayant une impédance de 4 à 8 ohms avec une capacité électrique adéquate pour éviter de les endommager.
 • Ne raccordez pas les bornes du système de haut-parleurs au châssis de la voiture et ne raccordez pas les bornes des haut-parleurs droit à celles du haut-parleur gauche.
 • Ne raccordez pas le câble de mise à la masse de cet appareil à la borne négative (-) du haut-parleur.
 • N'essayez pas de raccorder les haut-parleurs en parallèle.
 • Raccordez uniquement des haut-parleurs passifs. Le raccordement de haut-parleurs actifs (avec amplificateurs intégrés) aux bornes des haut-parleurs peut endommager l'appareil.
 • Pour éviter tout dysfonctionnement, n'utilisez pas les câbles des haut-parleurs intégrés installés dans votre voiture si l'appareil partage un câble négatif commun (-) pour les haut-parleurs droit et gauche.
 • Ne raccordez pas entre eux les cordons des haut-parleurs de l'appareil.
 Remarque sur le raccordement
 Si les haut-parleurs et l'amplificateur ne sont pas raccordés correctement, le message « FAILURE » s'affiche. Dans ce cas, assurez-vous que les haut-parleurs et l'amplificateur sont bien raccordés.

CDX-GT20W/GT200/GT200E/GT200S/GT250S
SECTION 2
DISASSEMBLY

Note : This set can be disassemble according to the following sequence.

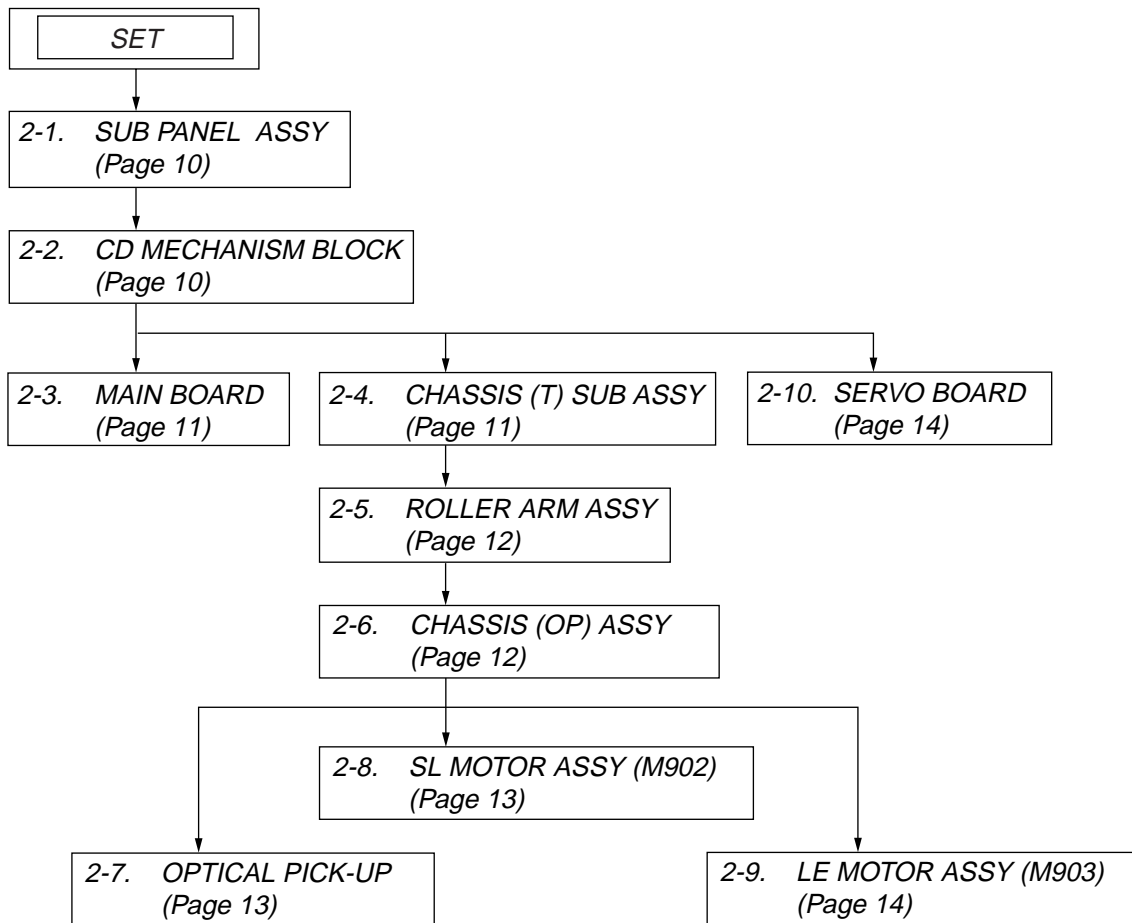

CDX-GT20W/GT200/GT200E/GT200S/GT250S

Note : Follow the disassembly procedure in the numerical order given.

2-1. SUB PANEL ASSY

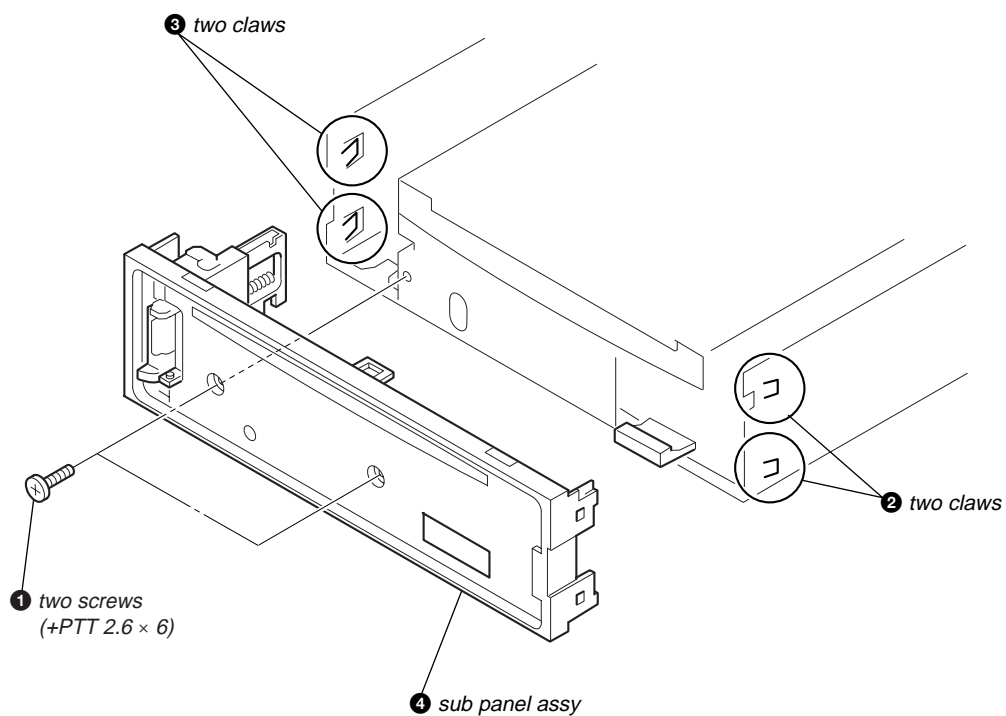

2-2. CD MECHANISM BLOCK

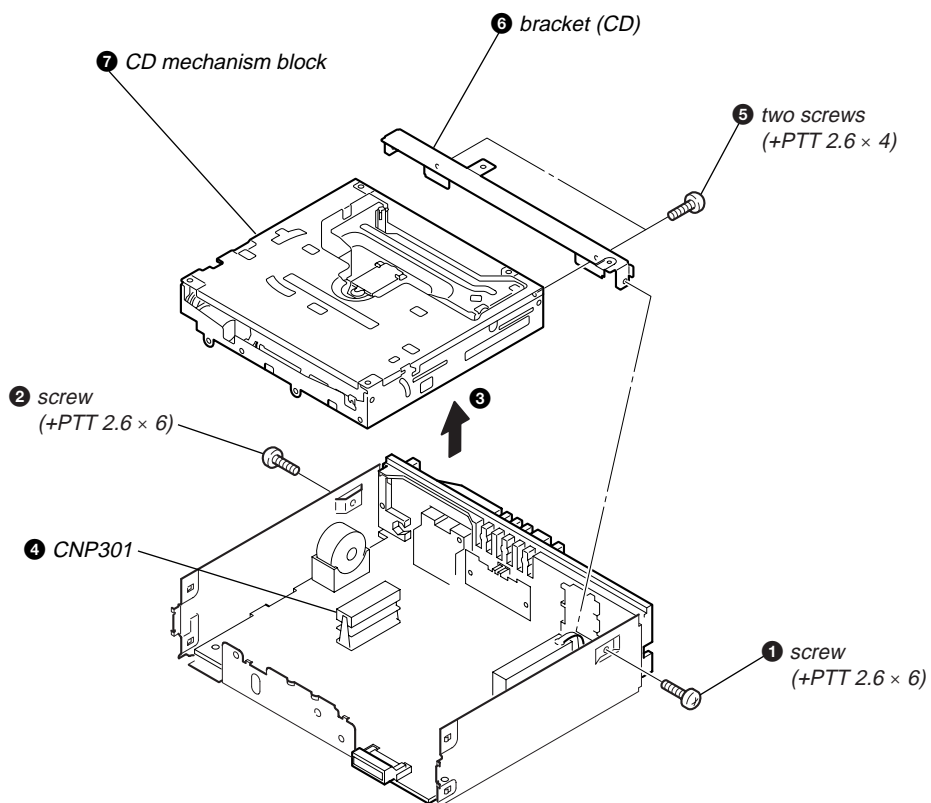

2-3. MAIN BOARD

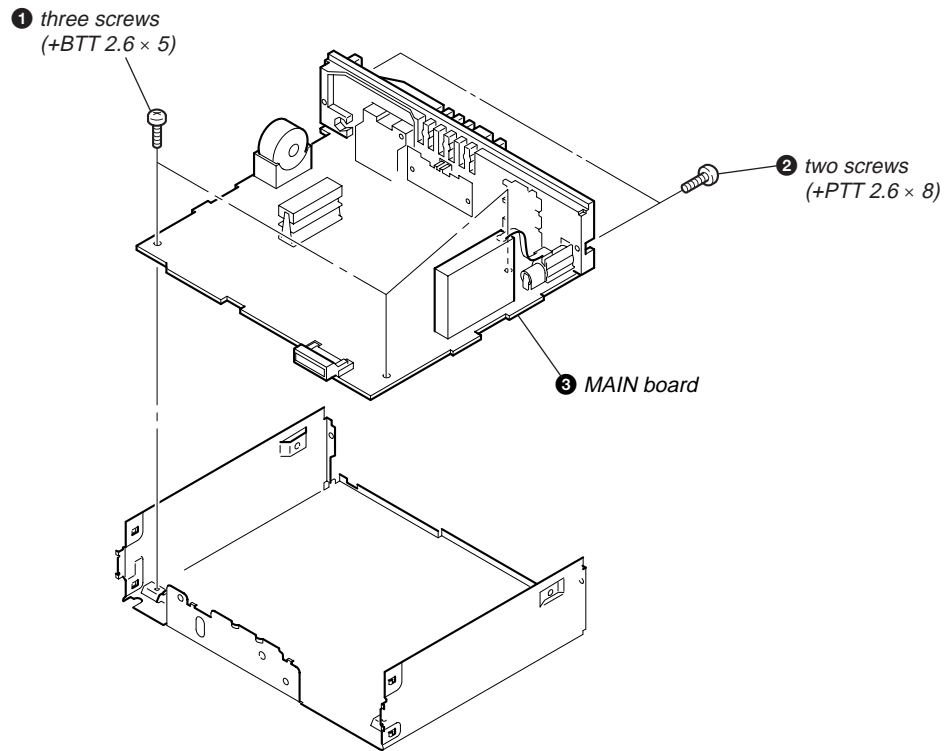

2-4. CHASSIS (T) SUB ASSY

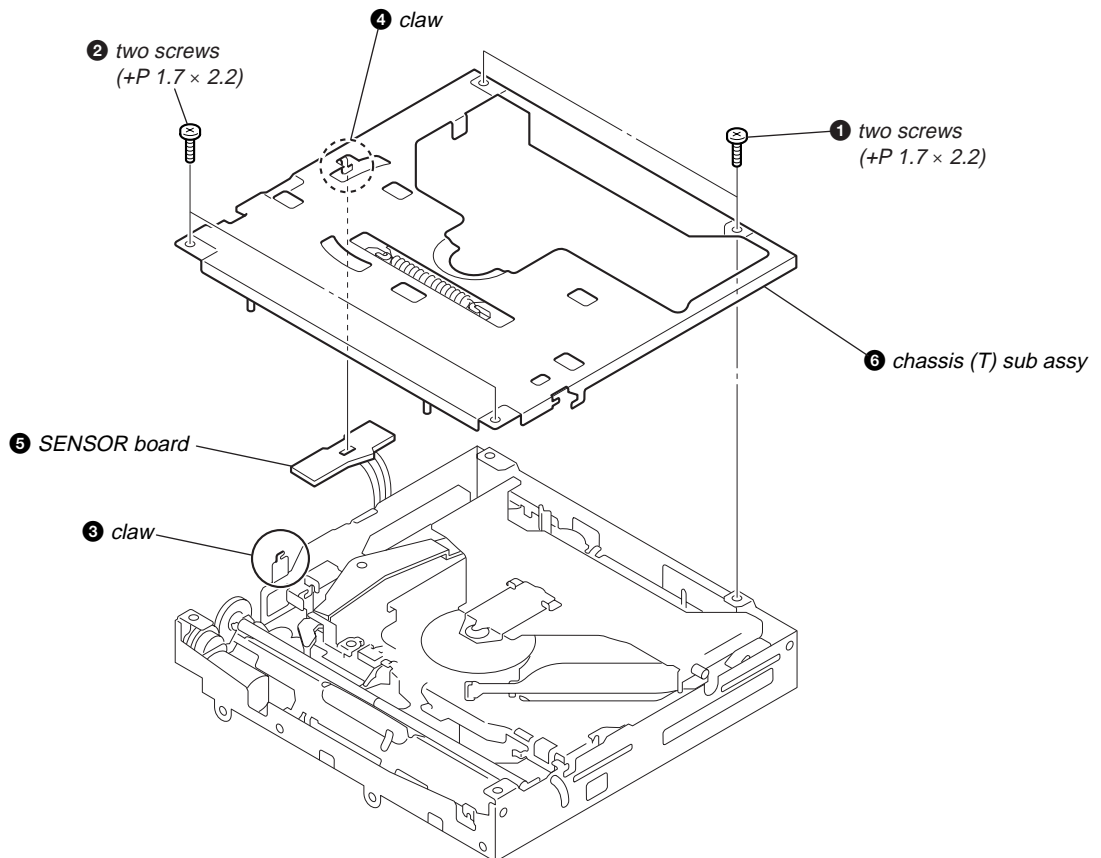

2-5. ROLLER ARM ASSY

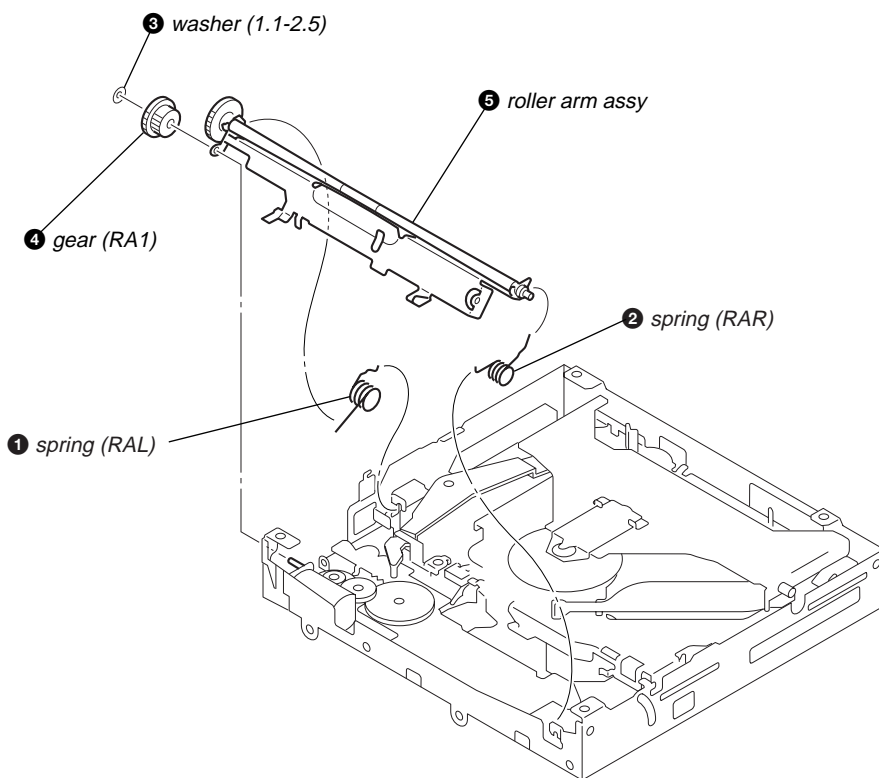

2-6. CHASSIS (OP) ASSY

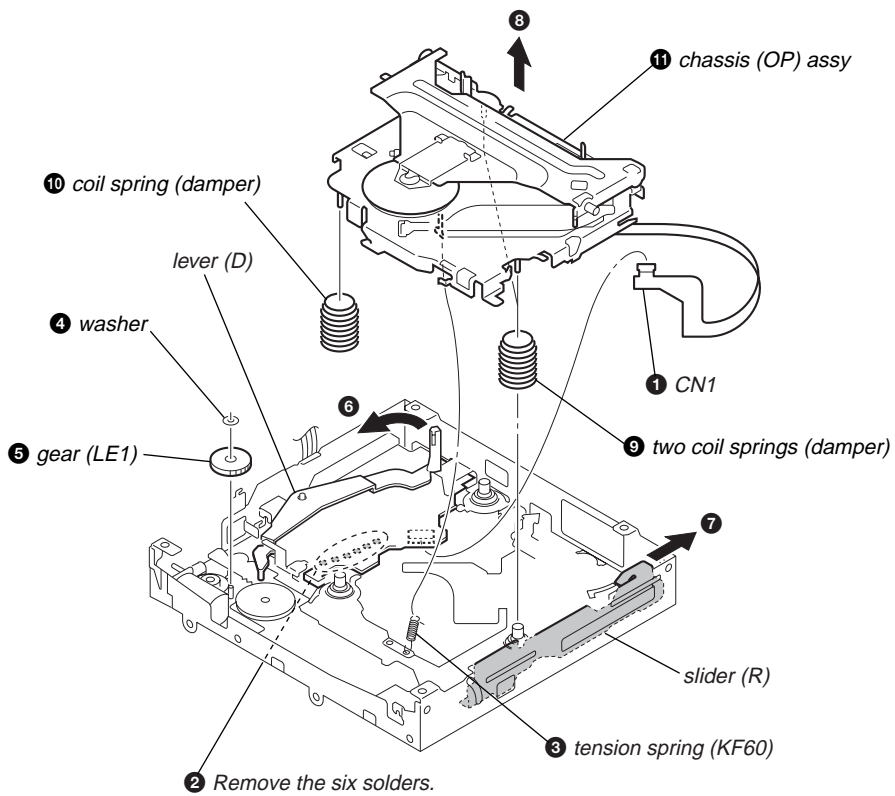

2-7. OPTICAL PICK-UP

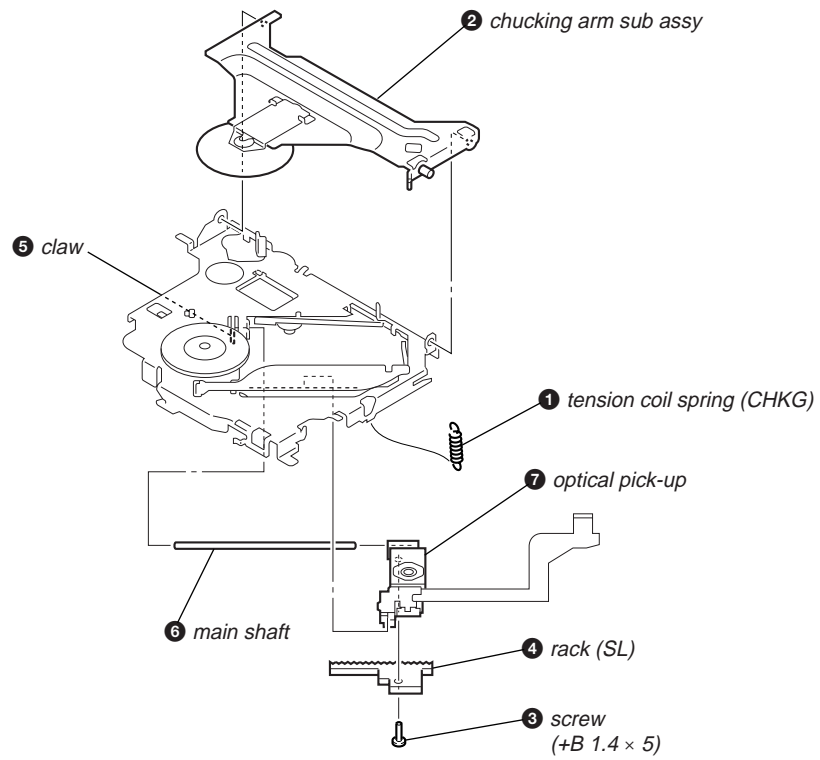

2-8. SL MOTOR ASSY (M902)

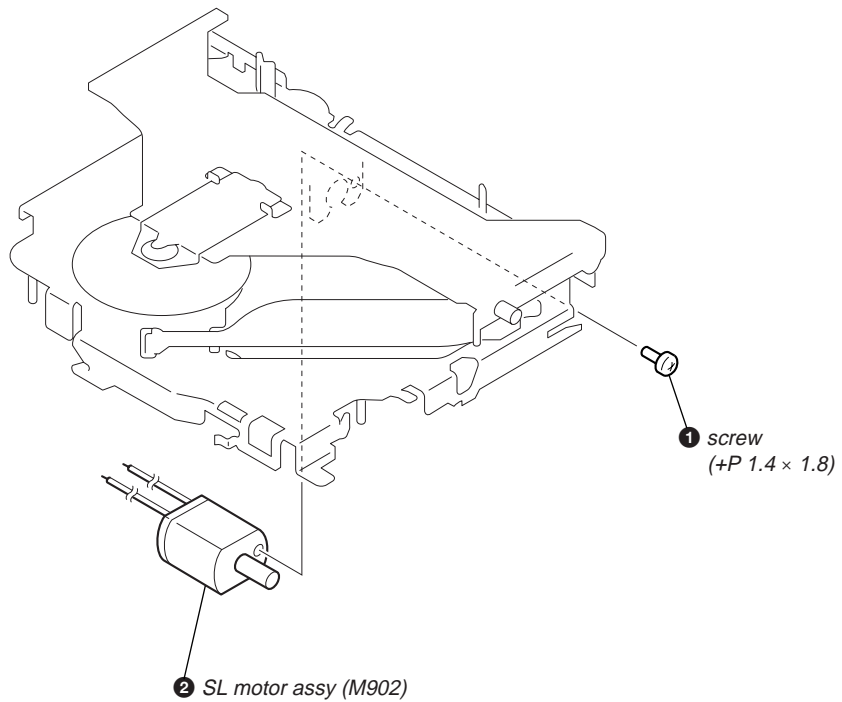

2-9. LE MOTOR ASSY (M903)

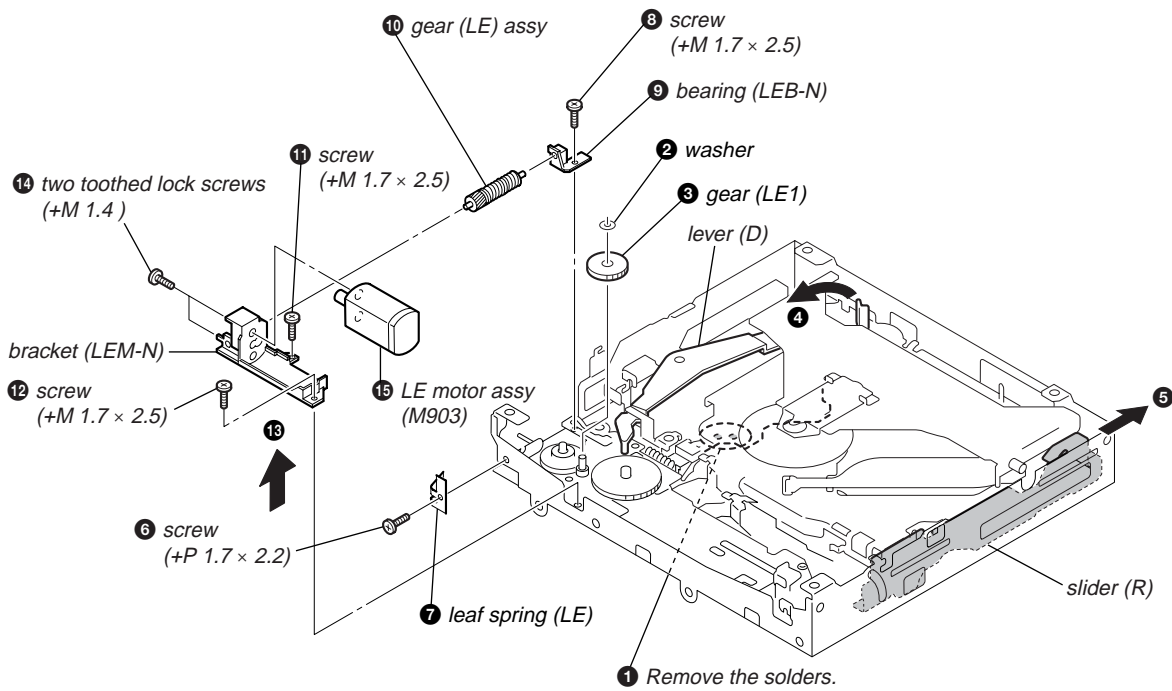

2-10. SERVO BOARD

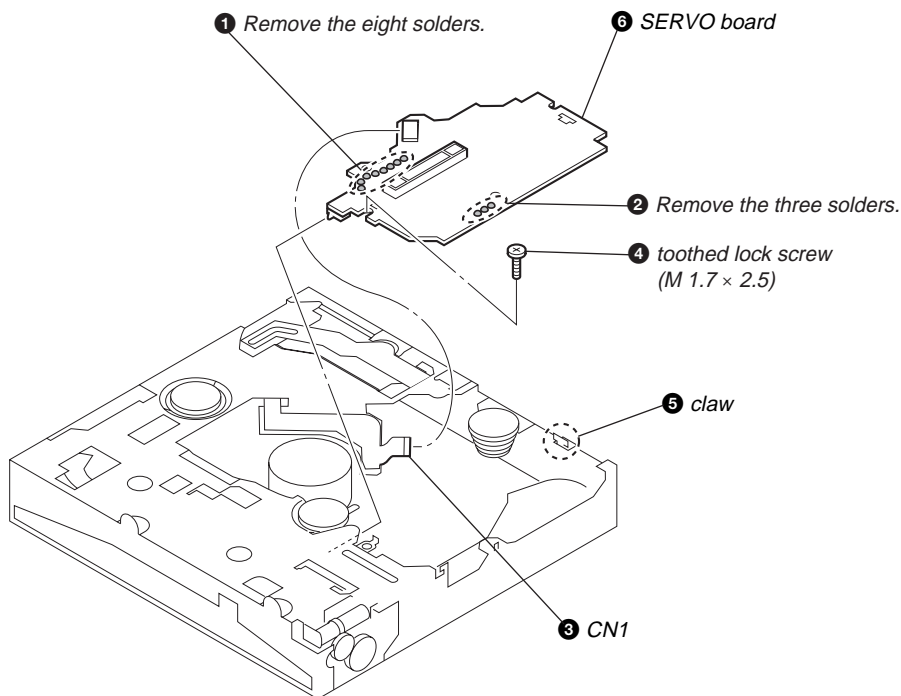

SECTION 3
DIAGRAMS

3-1. BLOCK DIAGRAM — CD SECTION —

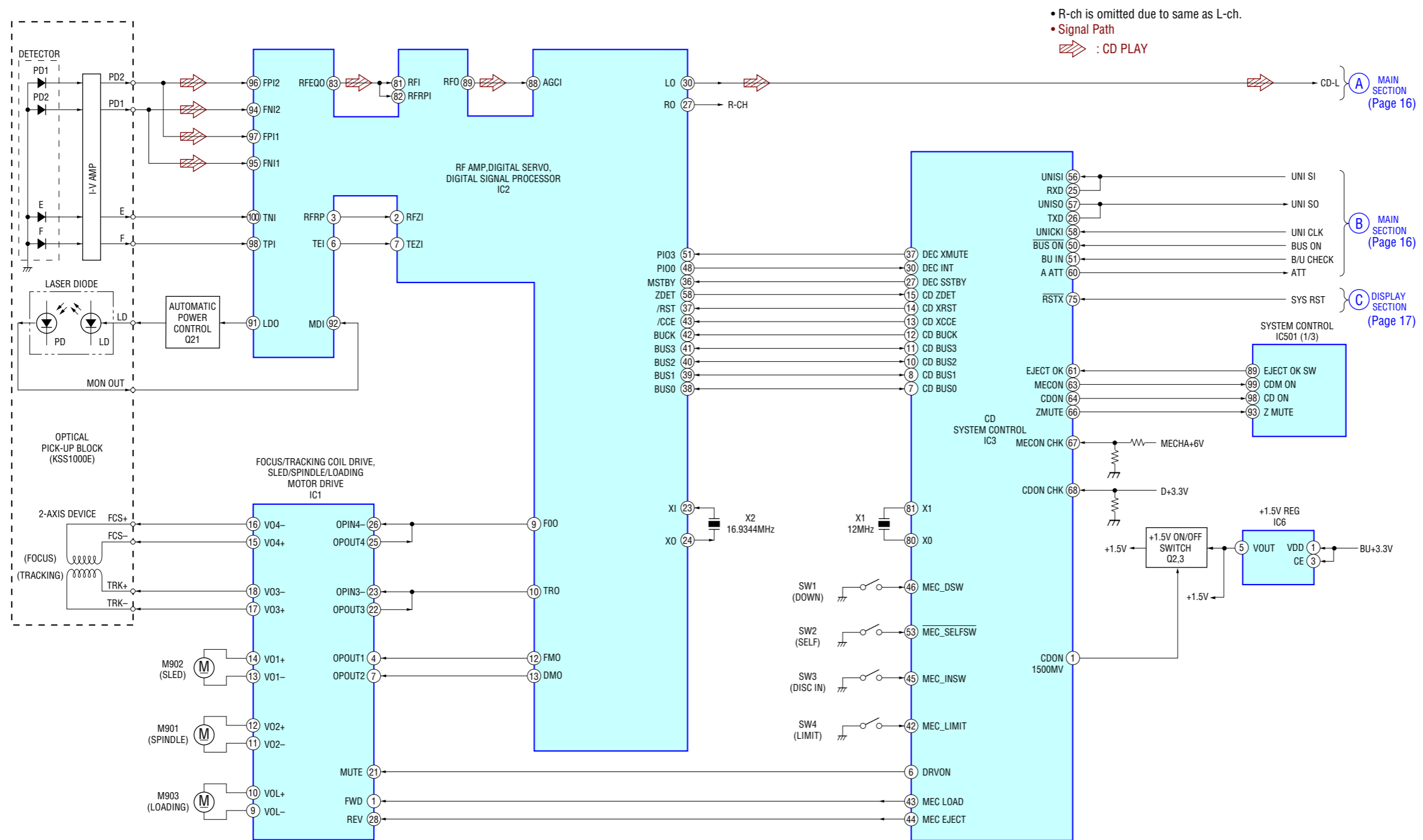

3-2. BLOCK DIAGRAM — MAIN SECTION —

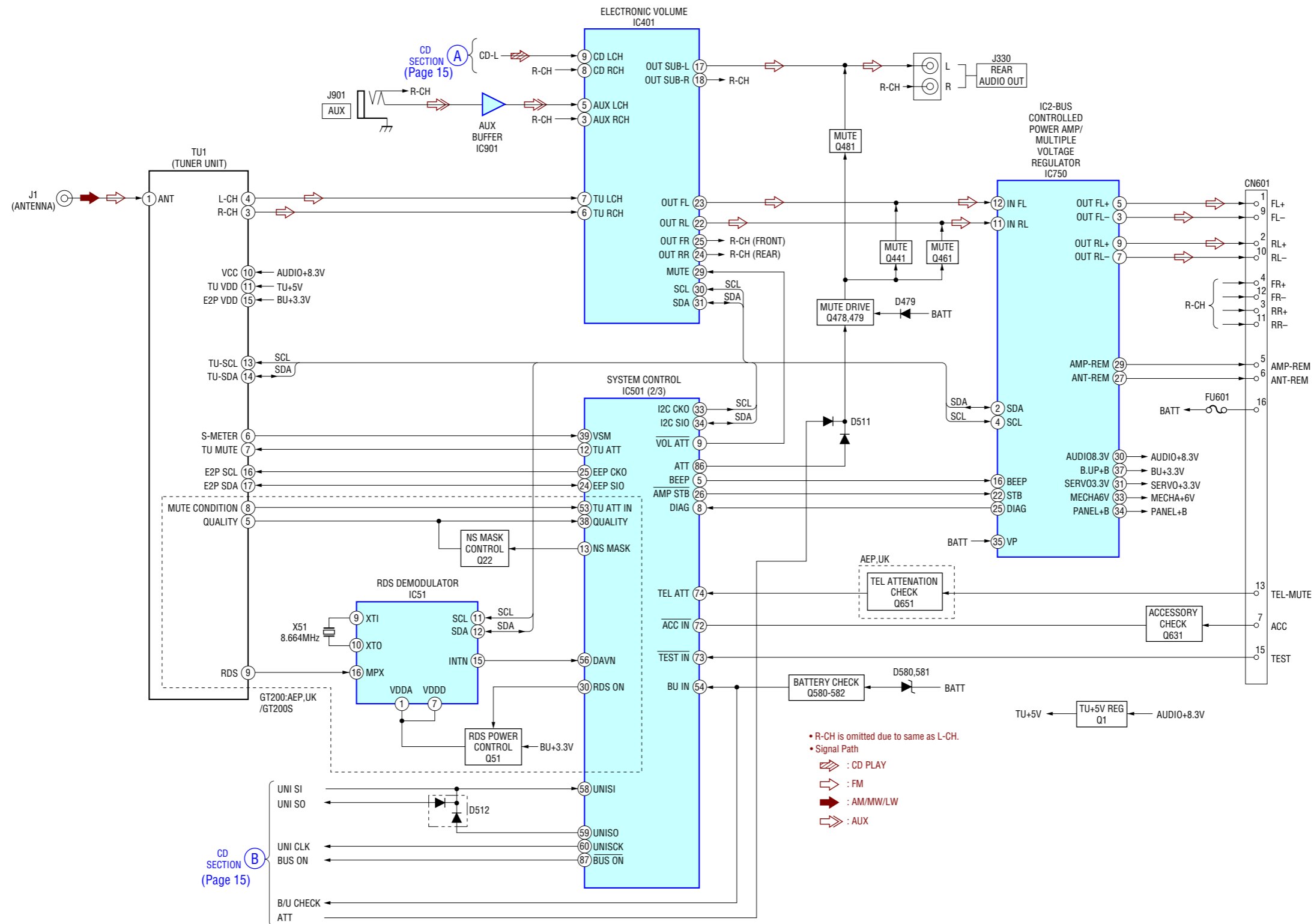

3-3. BLOCK DIAGRAM — DISPLAY SECTION —

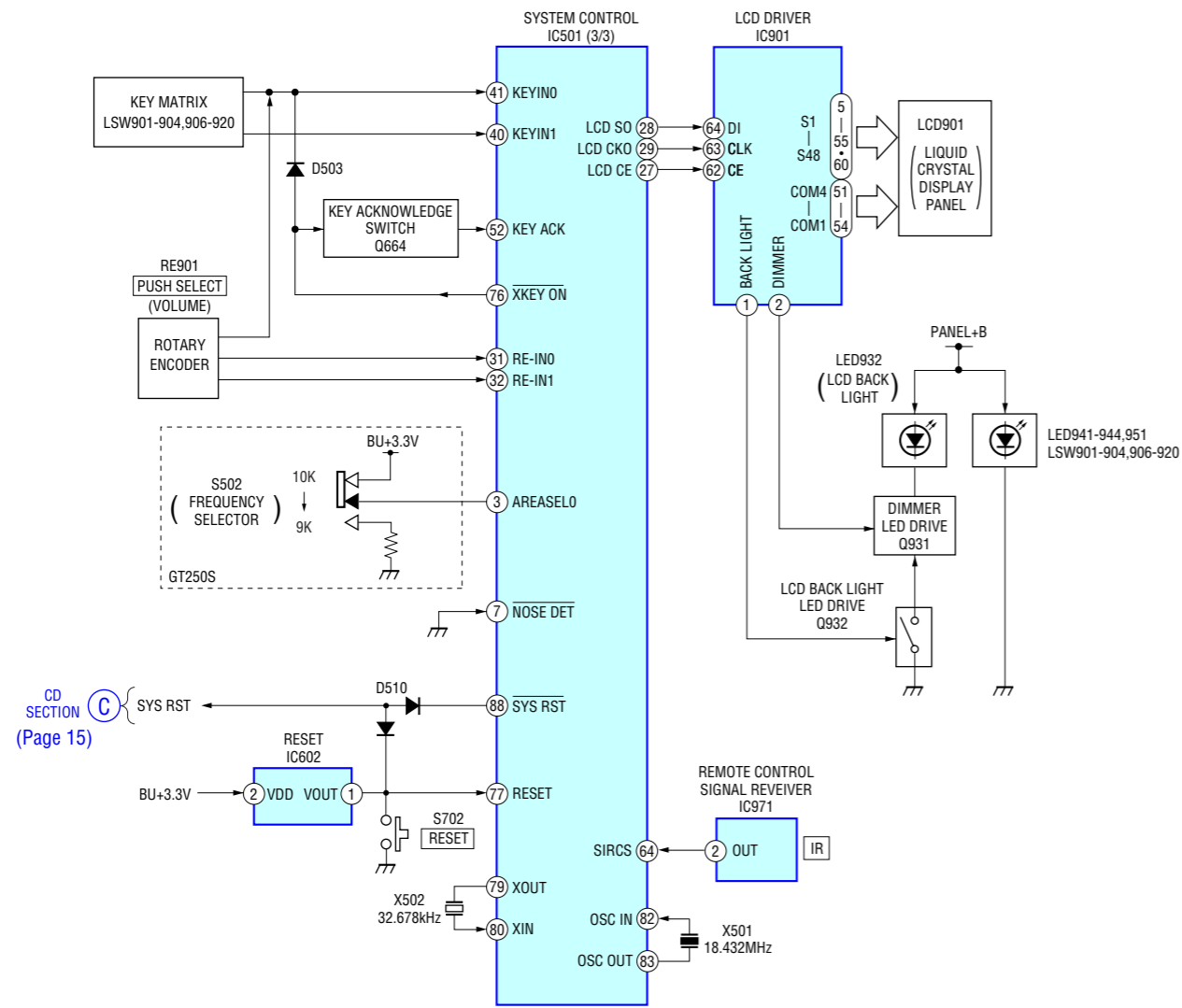

3-4. CIRCUIT BOARDS LOCATION

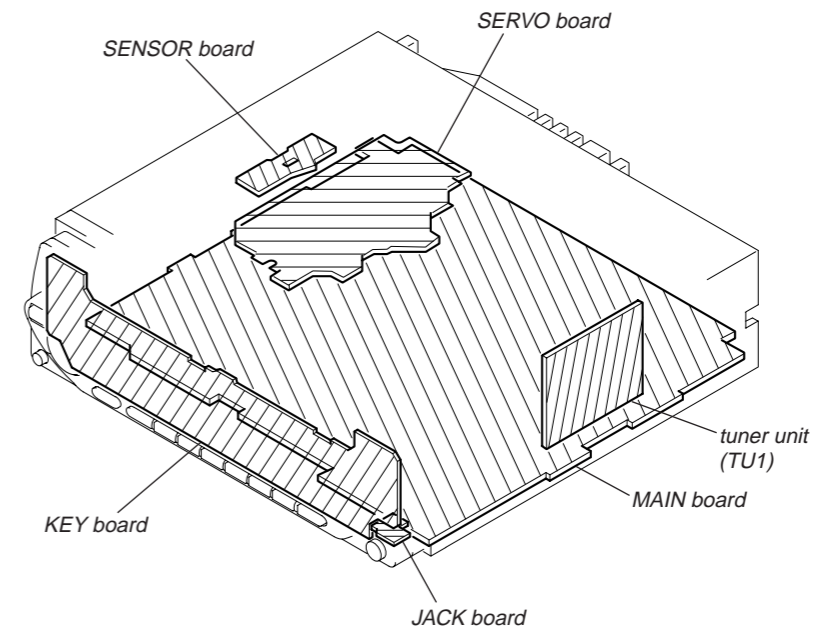

• NOTE FOR PRINTED WIRING BOARDS AND SCHEMATIC DIAGRAMS

THIS NOTE IS COMMON FOR PRINTED WIRING BOARDS AND SCHEMATIC DIAGRAMS.
(In addition to this, the necessary note is printed in each block.)

For schematic diagrams.

- Note:**
- All capacitors are in μF unless otherwise noted. (p: pF) 50 WV or less are not indicated except for electrolytics and tantalums.
 - All resistors are in Ω and $\frac{1}{4}W$ or less unless otherwise specified.
 - Δ : internal component.
 - \square : panel designation.

Note:
The components identified by mark Δ or dotted line with mark Δ are critical for safety. Replace only with part number specified.

Note:
Les composants identifiés par une marque Δ sont critiques pour la sécurité. Ne les remplacer que par une pièce portant le numéro spécifié.

- : B+ Line.
- : B- Line.
- : adjustment for repair.
- Voltages and waveforms are dc with respect to ground under no-signal (detuned) conditions.
- CD mechanism (1/2) and (2/2) sections no mark : CD PLAY
- Main (1/3), (2/3), (3/3) and Key sections no mark : FM
- () : AM/MW/LW
- < > : CD PLAY
- * : Impossible to measure
- Voltages are taken with a VOM (Input impedance 10 M Ω). Voltage variations may be noted due to normal production tolerances.
- Waveforms are taken with an oscilloscope. Voltage variations may be noted due to normal production tolerances.
- Circled numbers refer to waveforms.
- Signal path.
- : CD PLAY
- : FM
- : AM/MW/LW
- : AUX

For printed wiring boards.

- Note:**
- : parts extracted from the component side.
 - : parts extracted from the conductor side.
 - \circ : Through hole.
 - : Pattern from the side which enables seeing. (The other layers' patterns are not indicated.)

Caution:
Pattern face side: Parts on the pattern face side seen from the (Side B) pattern face are indicated.
Parts face side: Parts on the parts face side seen from the (Side A) parts face are indicated.

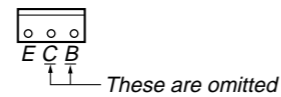
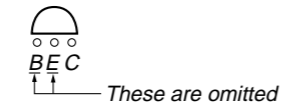
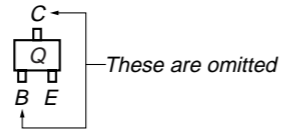

• WAVEFORMS

— SERVO BOARD — (CD PLAY)

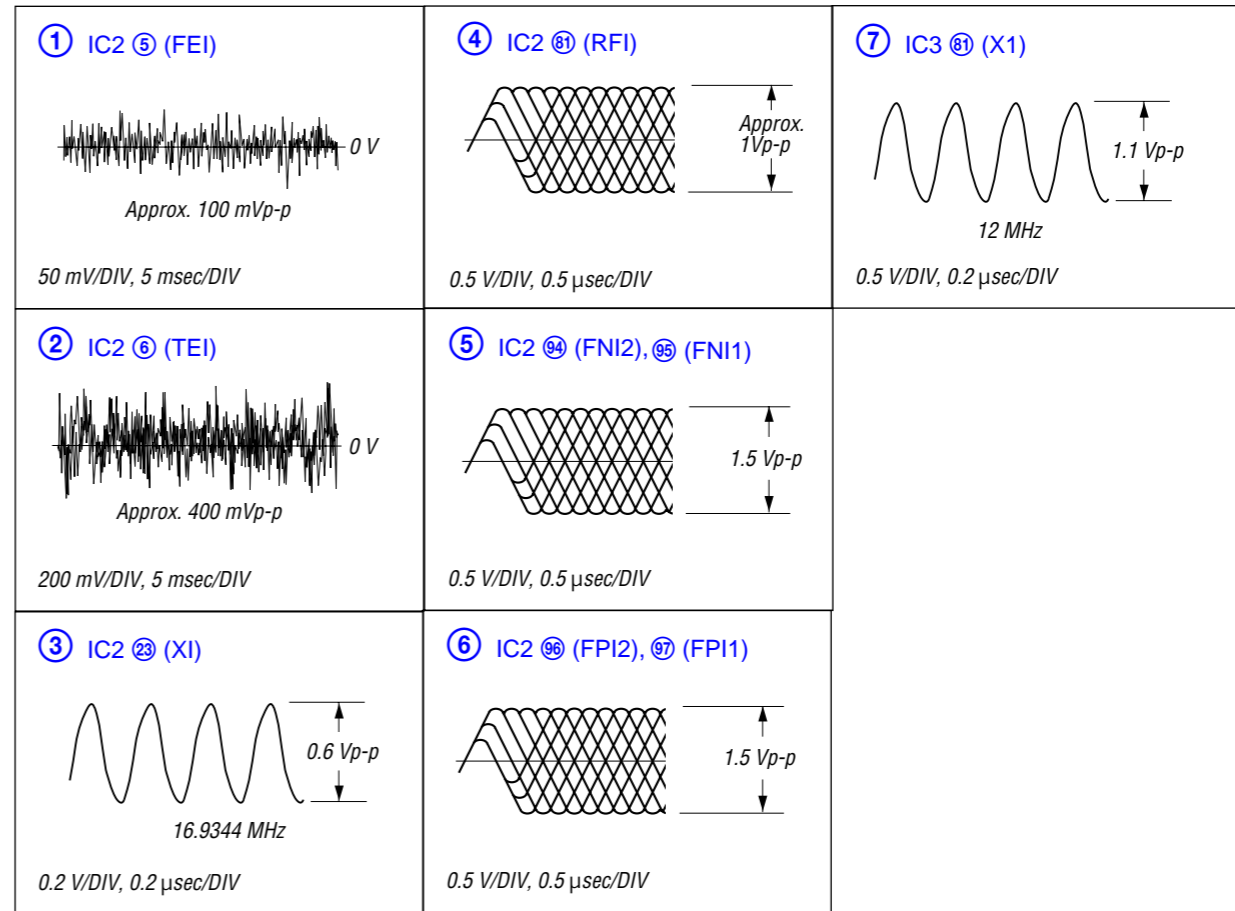

— MAIN BOARD —

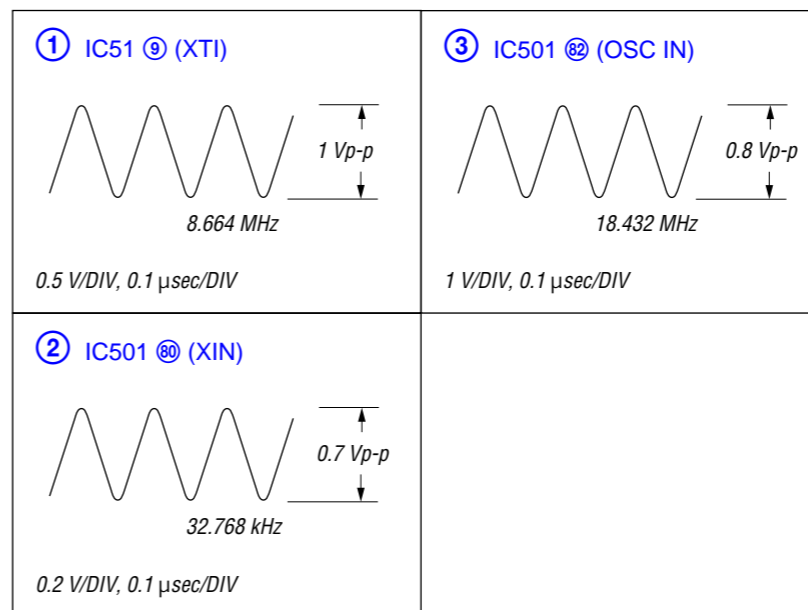

3-5. PRINTED WIRING BOARDS — CD MECHANISM SECTION — • Refer to page 17 for Circuit Boards Location.  : Uses unleaded solder.

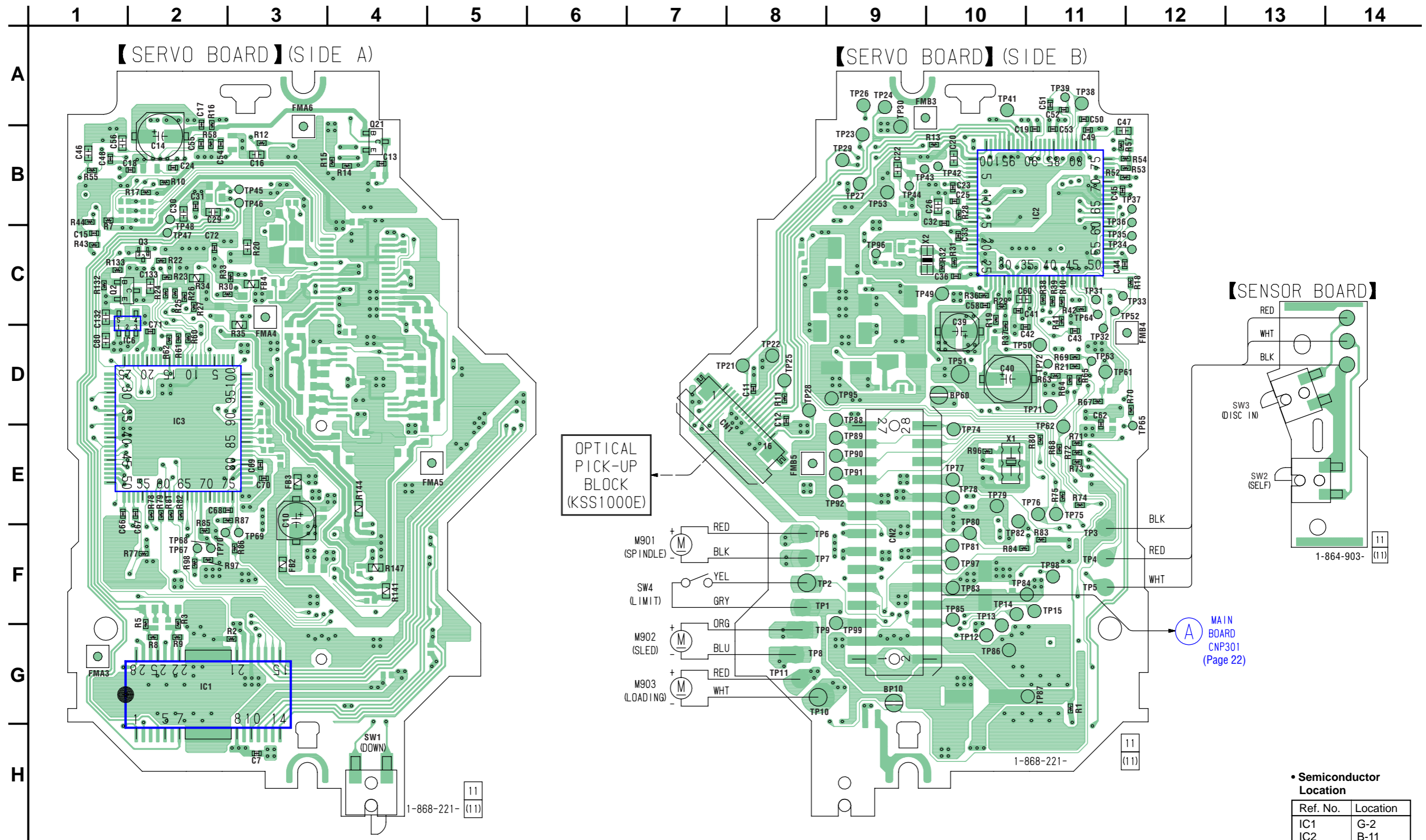

OPTICAL PICK-UP BLOCK (KSS1000E)

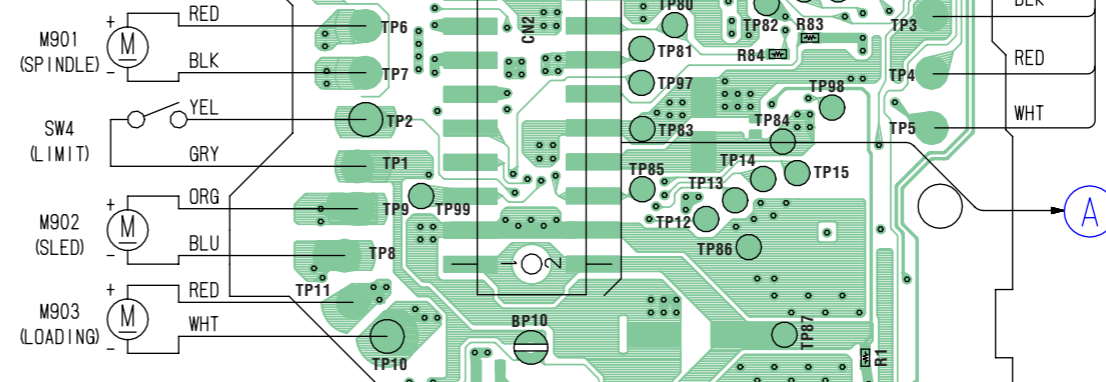

MAIN BOARD CNP301 (Page 22)

• Semiconductor Location

Ref. No.	Location
IC1	G-2
IC2	B-11
IC3	D-2
IC6	D-2
Q2	C-1
Q3	C-2
Q21	B-4

3-6. SCHEMATIC DIAGRAM — CD MECHANISM SECTION (1/2) — • Refer to page 18 for Waveforms.

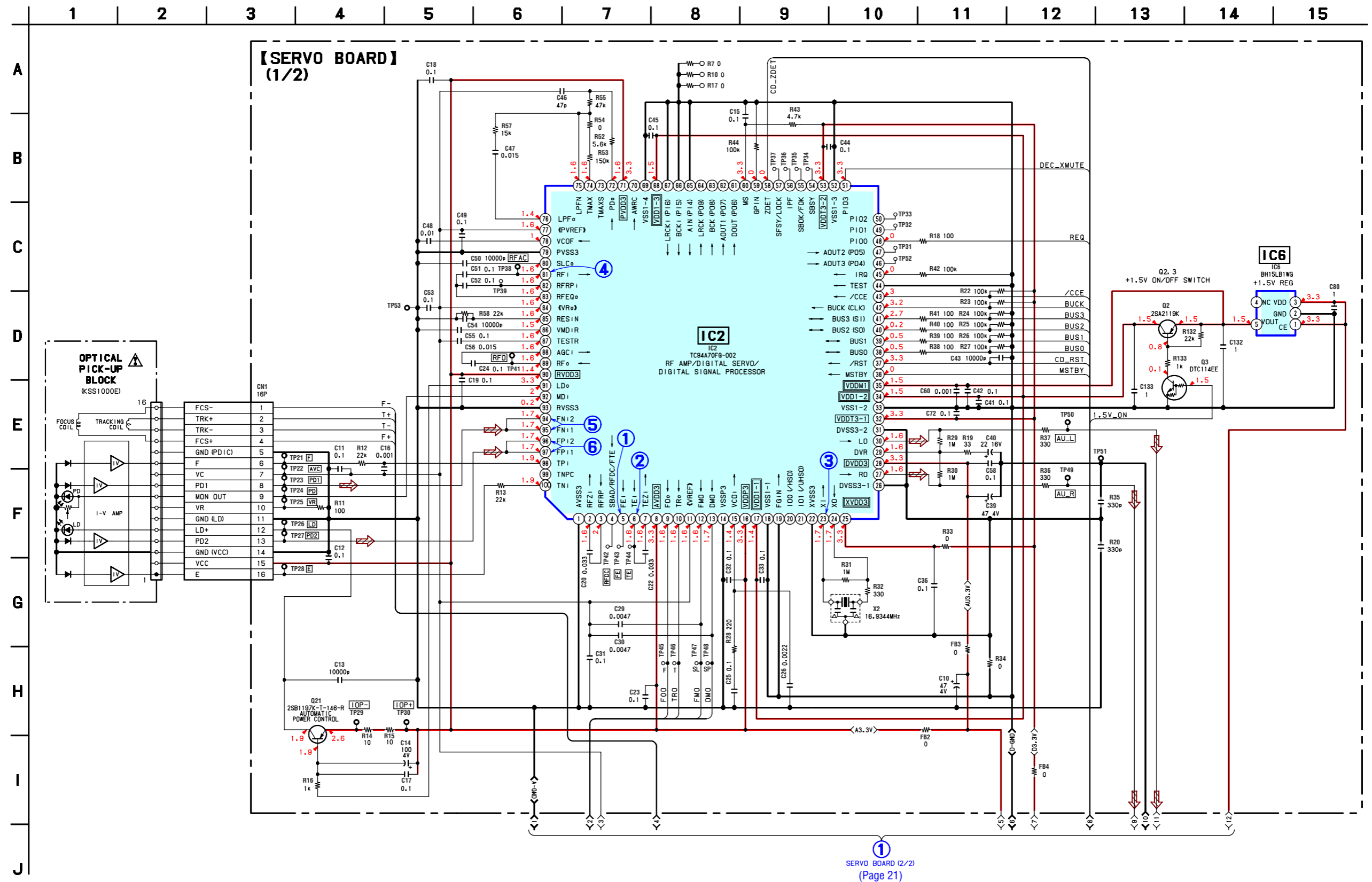

3-7. SCHEMATIC DIAGRAM — CD MECHANISM SECTION (2/2) —

- Refer to page 18 for Waveforms.
- Refer to page 28 for IC Block Diagrams.
- Refer to page 30 for IC Pin Descriptions.

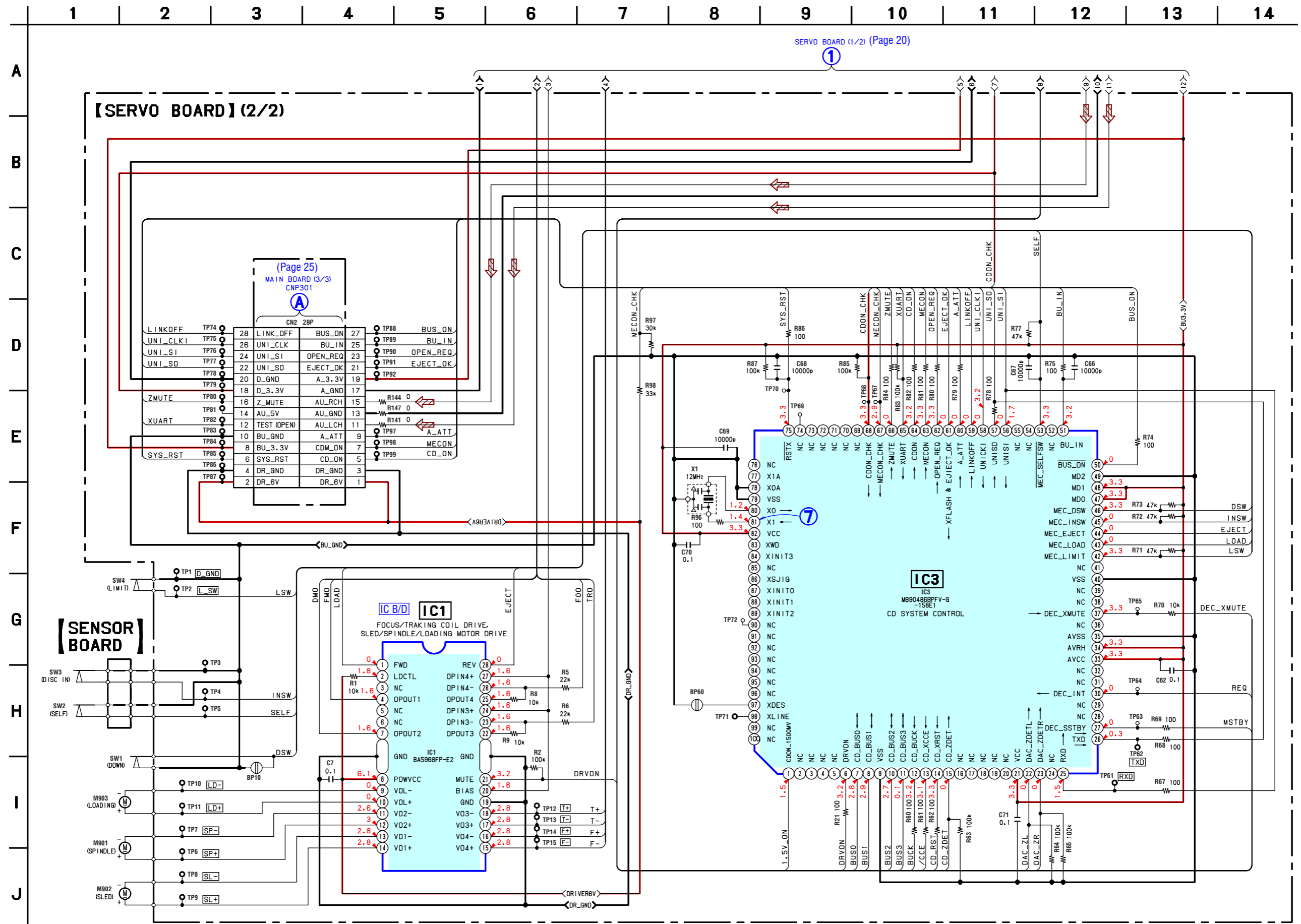

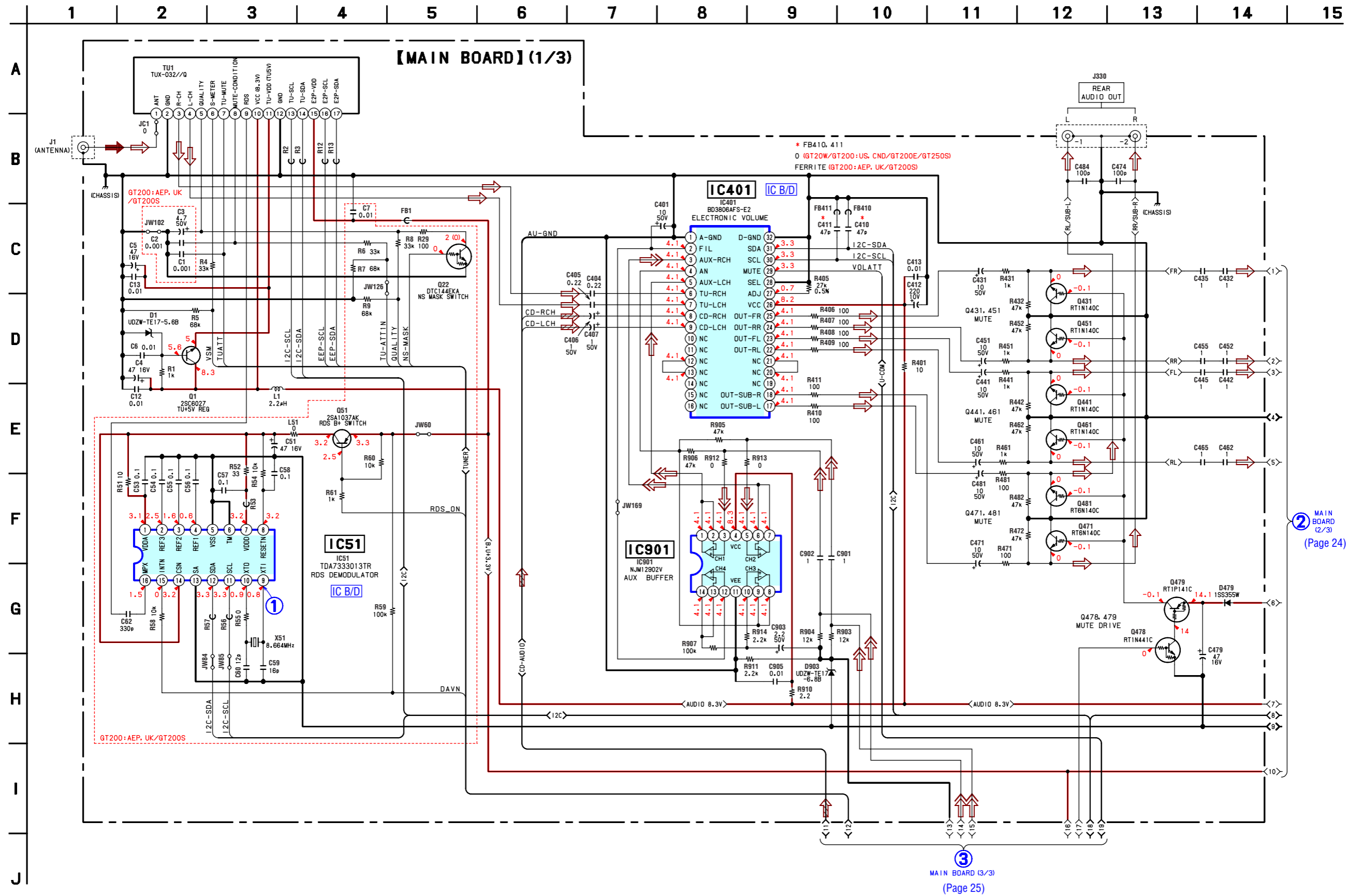

3-9. SCHEMATIC DIAGRAM — MAIN SECTION (1/3) —

- Refer to page 18 for Waveforms.
- Refer to page 28 for IC Block Diagrams.

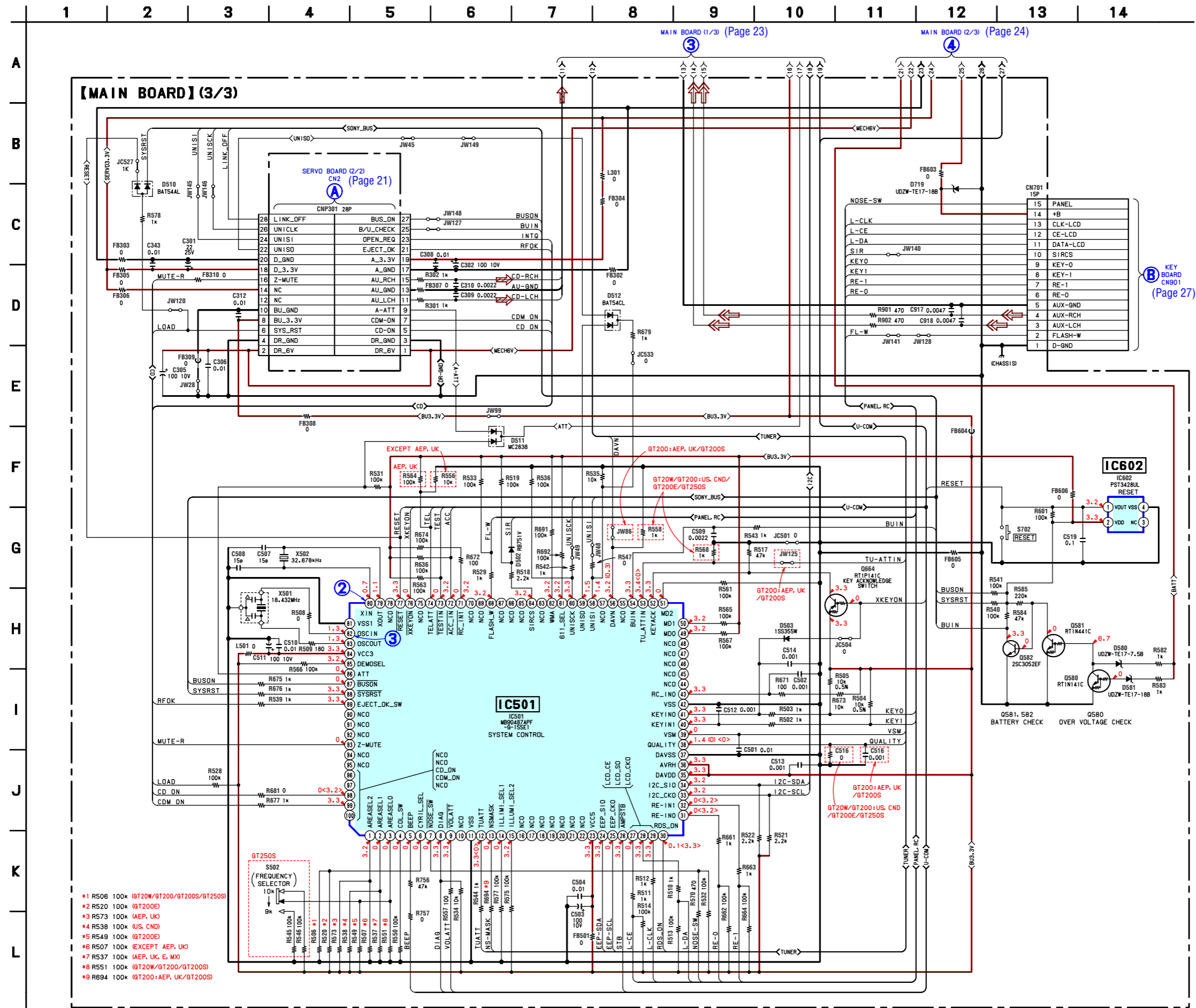

3-11. SCHEMATIC DIAGRAM — MAIN SECTION (3/3) — • Refer to page 18 for Waveforms. • Refer to page 32 for IC Pin Descriptions.



3-12. PRINTED WIRING BOARDS — KEY SECTION — • Refer to page 17 for Circuit Boards Location.  : Uses unleaded solder.

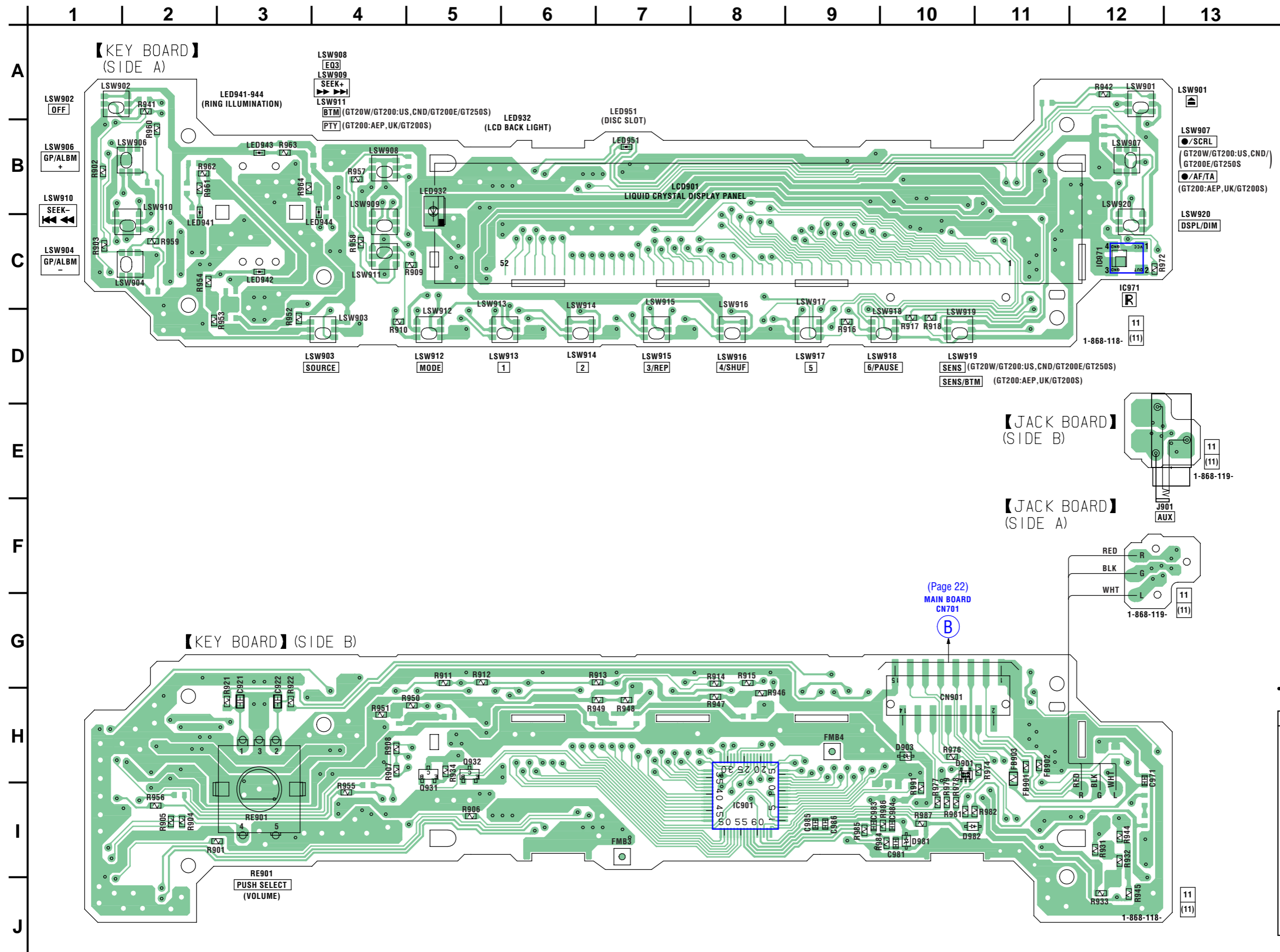

• Semiconductor Location

Ref. No.	Location
D901	H-10
D903	H-10
D981	I-10
D982	I-10
IC901	I-8
IC971	C-12
LED932	B-5
LED941	C-2
LED942	C-3
LED943	B-3
LED944	C-4
LED951	B-7
Q931	H-5
Q932	H-5

3-13. SCHEMATIC DIAGRAM — KEY SECTION —

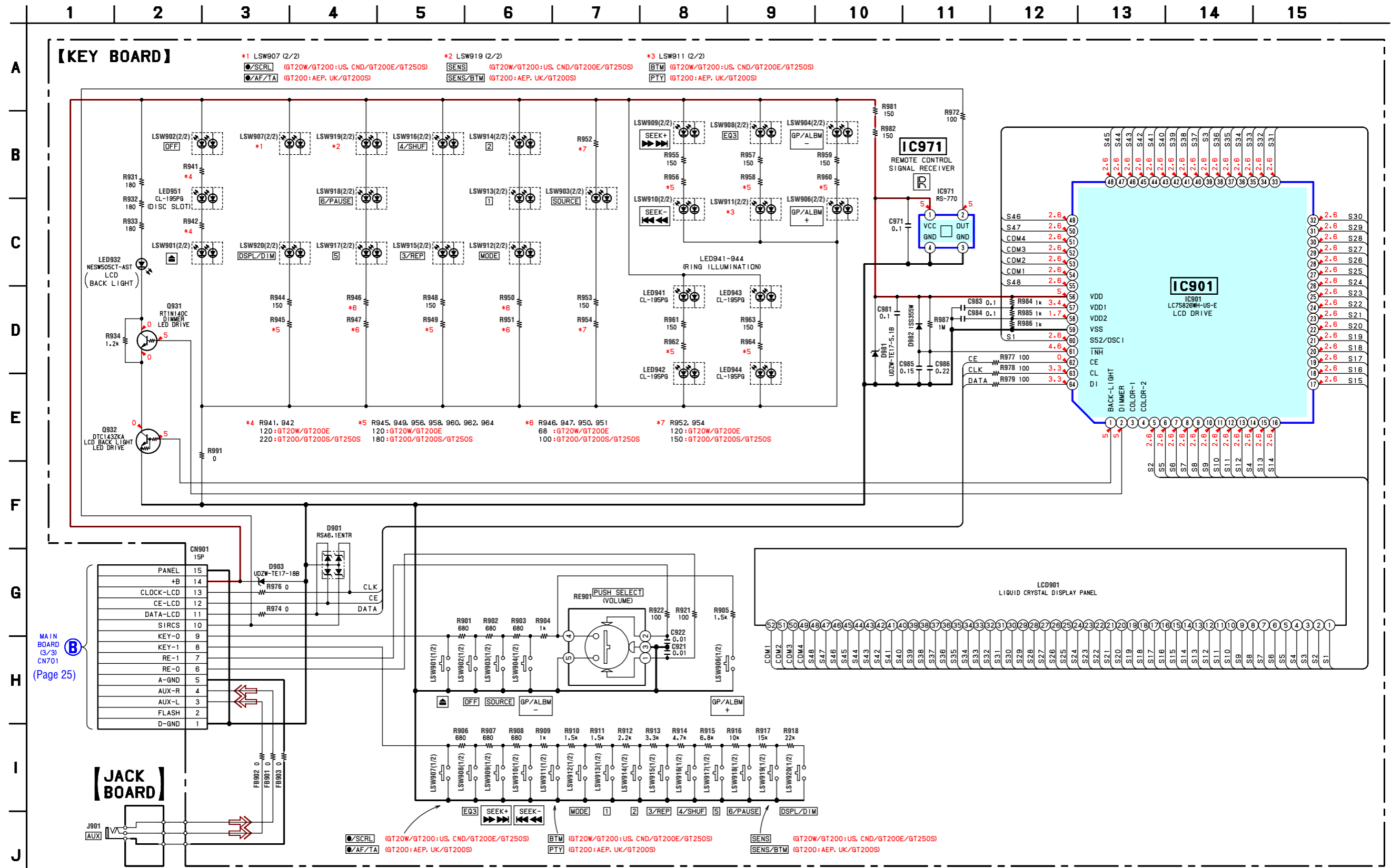

• IC BLOCK DIAGRAMS

IC1 BA5968FP-E2 (SERVO Board (2/2))

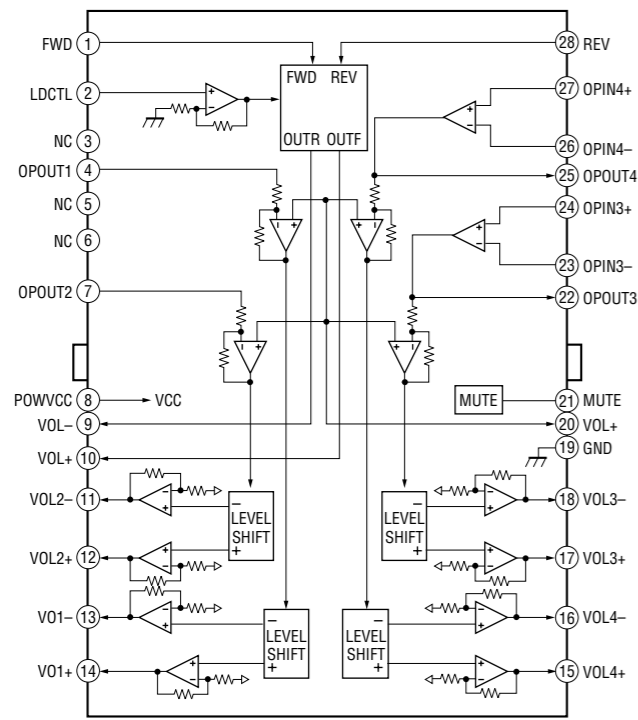

IC51 TDA7333013TR (MAIN Board (1/3))

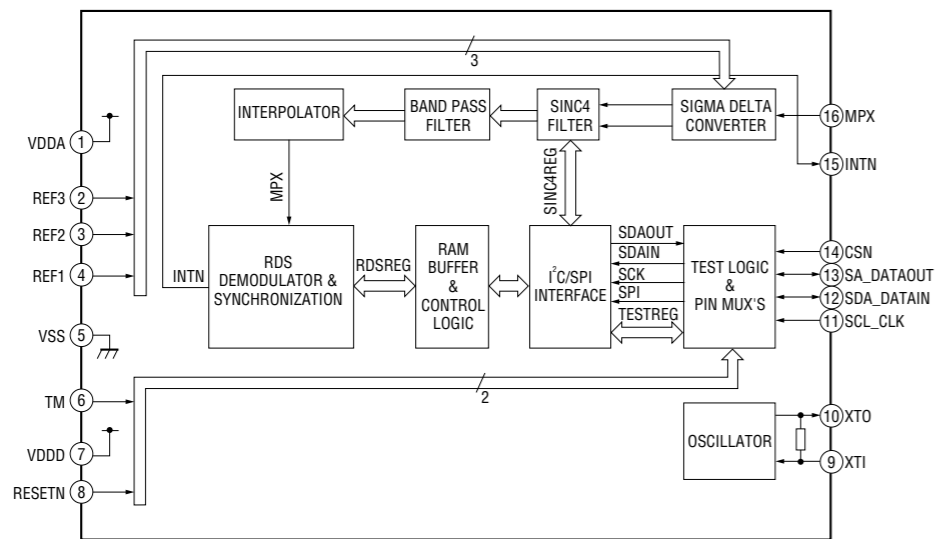

IC401 BD3806AFS-E2 (MAIN Board (1/3))

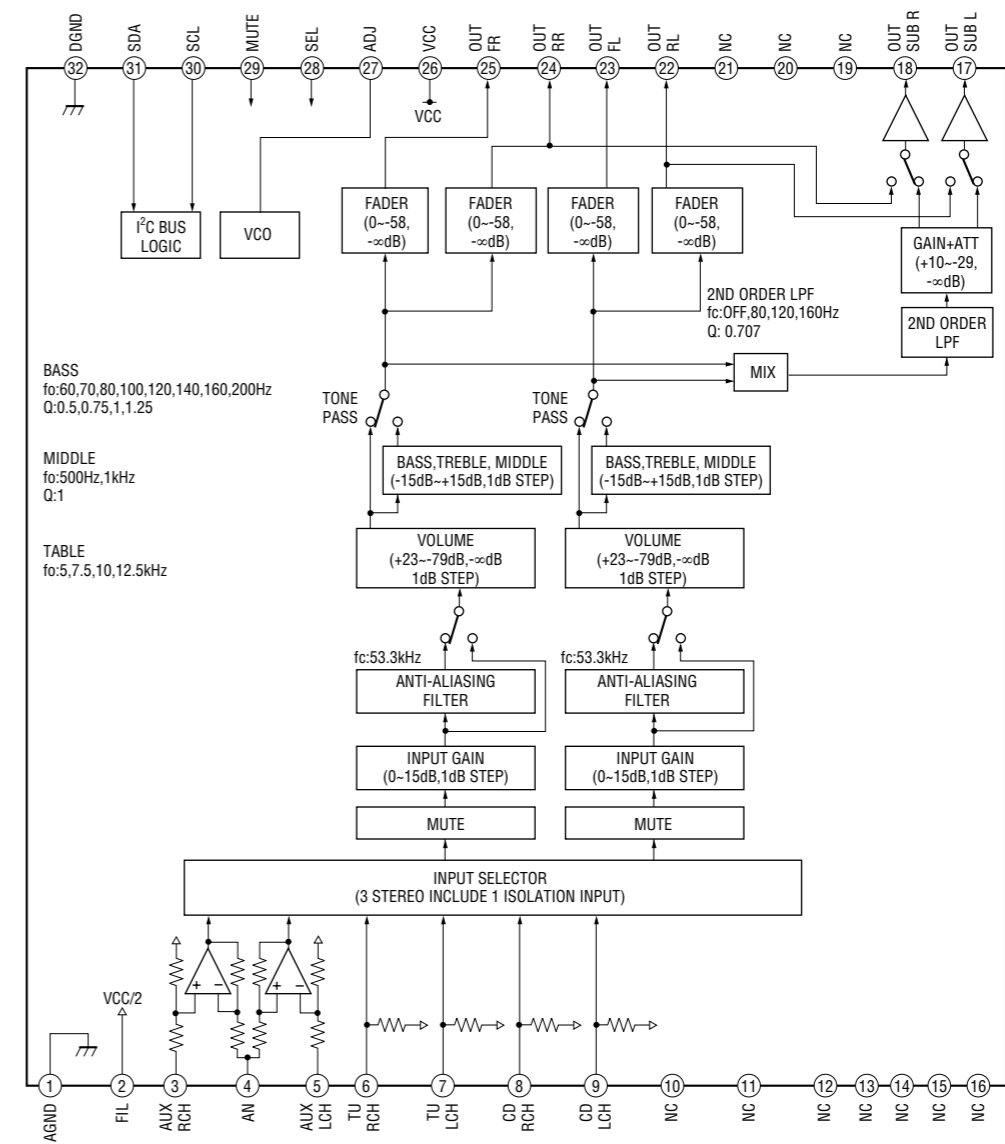

IC750 TDA8588BJ/N2/R1 (MAIN Board (2/3))

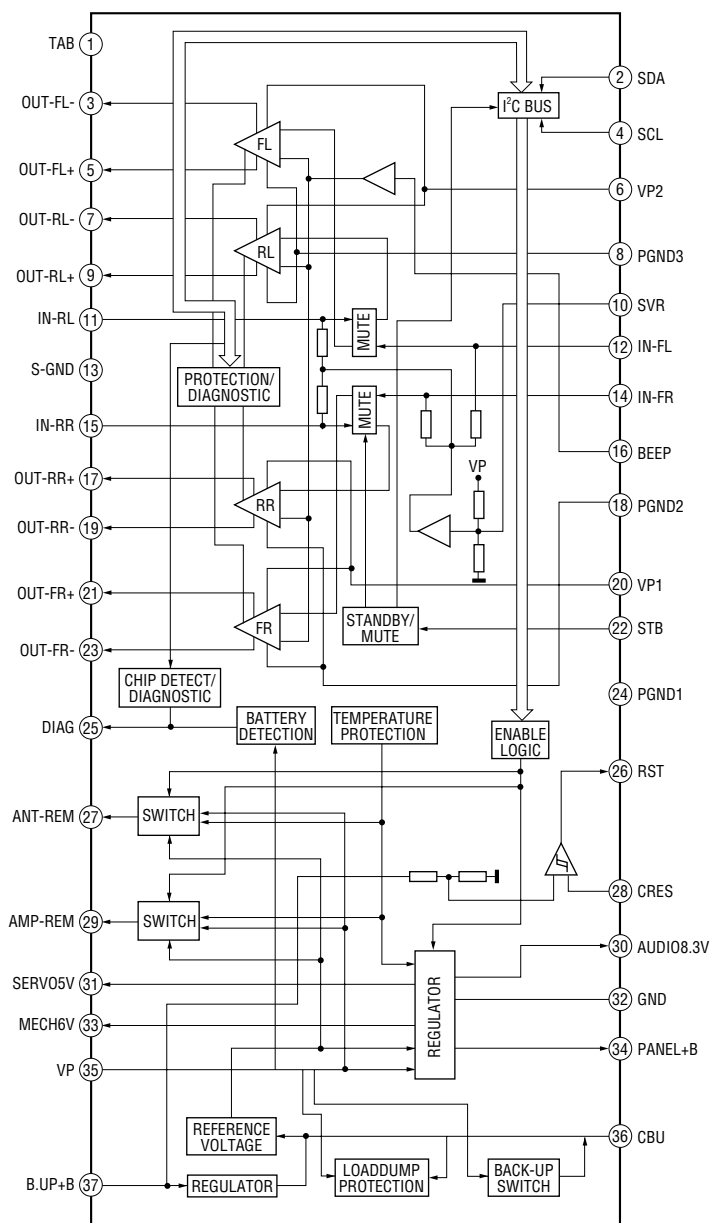

CDX-GT20W/GT200/GT200E/GT200S/GT250S

• IC Pin Descriptions

IC3 MB90486BPFV-G-158E1 (CD SYSTEM CONTROL) (SERVO BOARD (2/2))

Pin No.	Pin Name	I/O	Pin Description
1	CDON 1500MV	O	Servo 1.5 V power supply control signal output
2 to 5	NC	—	Not used. (Open)
6	DRVON	O	Motor drive on/off control signal output
7	CD BUS0	I/O	Bus data signal input/output 0
8	CD BUS1	I/O	Bus data signal input/output 1
9	VSS	—	Ground pin
10	CD BUS2	I/O	Bus data signal input/output 2
11	CD BUS3	I/O	Bus data signal input/output 3
12	CD BUCK	O	Bus clock signal output
13	CD XCCE	O	Chip enable signal output
14	CD XRST	O	Reset signal output
15	CD ZDET	I	Zero detection signal input
16 to 20	NC	—	Not used. (Open)
21	VCC	—	Power supply pin (+3.3 V)
22	DAC ZDETL	I	Zero data detection signal input (L-ch)
23	DAC ZDETR	I	Zero data detection signal input (R-ch)
24	NC	—	Not used. (Open)
25	RXD	I	UART RXD data signal input (MCBUS/Flash data input)
26	TXD	O	UART TXD data signal output (MCBUS/Flash data output)
27	DEC SSTBY	O	SRAM STANDBY mode control signal output
28, 29	NC	—	Not used. (Open)
30	DEC INT	I	Request signal input
31, 32	NC	—	Not used. (Open)
33	AVCC	—	Power supply pin (+3.3 V) for A/D converter
34	AVRH	—	External reference voltage for A/D converter
35	AVSS	—	Ground pin
36	NC	—	Not used. (Open)
37	DEC XMUTE	O	Mute signal output L: mute
38, 39	NC	—	Not used. (Open)
40	VSS	—	Ground pin
41	NC	—	Not used. (Open)
42	MEC LIMIT	I	Sled limit in detection switch signal input
43	MEC LOAD	O	Loading motor signal output (Load direction)
44	MEC EJECT	O	Loading motor signal output (Eject direction)
45	MEC INSW	I	Pack-in detection signal input
46	MEC DSW	I	Chucking end detection switch signal input
47, 48	MD0, MD1	I	CPU operation mode designation signal input (Connect to Vcc.)
49	MD2	I	CPU operation mode designation signal input (Connect to Vss.)
50	BUS ON	I	Bus on signal input L: bus on
51	BU IN	I	Backup on/off signal input H: backup on, L: backup off
52	NC	—	Not used. (Open)
53	MEC SELFSW	I	Disc insert detection switch signal input L: disc in interruption
54, 55	NC	—	Not used. (Open)
56	UNISI	I	Serial data signal input
57	UNISO	O	Serial data signal output
58	UNICKI	I	Serial clock signal input
59	LINEOFF	O	Line off signal output
60	A ATT	O	Audio attenuation signal output H: ATT on
61	EJECT OK	I	Front panel open signal input H: eject
62	OPEN REQ	O	Front panel open/close request signal output H: open request
63	MECON	O	Mechanism deck power supply control signal output

Pin No.	Pin Name	I/O	Pin Description
64	CDON	O	Servo power supply control signal output H: power on
65	XUART	I	Sony-Bus/MC-Bus change signal input H: Sony-Bus, L: MC-Bus
66	ZMUTE	O	Zero detection mute signal output
67	MECON CHK	I	MECON rising detection signal input
68	CDON CHK	I	CDON rising detection signal input
69 to 74	NC	—	Not used. (Open)
75	RSTX	I	System reset signal input
76	NC	—	Not used. (Open)
77	X1A	—	Sub-clock connect pin Not used in this set. (Open)
78	X0A	—	Sub-clock connect pin Not used in this set. (Connect to Vss.)
79	VSS	—	Ground pin
80	X0	I	Main-clock connect pin (12 MHz)
81	X1	O	Main-clock connect pin (12 MHz)
82	VCC	—	Power supply pin (+3.3 V)
83	XWD	I	Not used in this set. (Open)
84	XINIT3	I	Not used in this set. (Open)
85	NC	—	Not used. (Open)
86	XSJIG	I	Not used in this set. (Open)
87 to 89	XINIT0 to 2	I	Not used in this set. (Open)
90 to 96	NC	—	Not used. (Open)
97	XDES	I	Mode select pin
98	XLIN	I	Not used in this set. (Open)
99, 100	NC	—	Not used. (Open)

CDX-GT20W/GT200/GT200E/GT200S/GT250S

IC501 MB90487APF-G-155E1 (SYSTEM CONTROL) (MAIN BOARD (3/3))

Pin No.	Pin Name	I/O	Pin Description
1	AREASEL2	I	Destination setting pin
2	AREASEL1	I	Destination setting pin
3	AREASEL0	I	Destination setting pin
4	COL SW	I	Illumination color select signal input
5	BEEP	O	Beep signal output
6	CYRIL SEL	I	Cyril select signal input
7	NOSE SW	I	Front panel open/close detect signal input
8	DIAG	I	Power AMP status signal input
9	VOL ATT	O	Electronic volume attenuate control signal output
10	NCO	O	Not used. (Open)
11	VSS	—	Ground pin
12	TU ATT	O	Tuner mute control signal output
13	NS MASK	O	Noise mask signal output (GT200: AEP, UK model/GT200S only)
14	ILLUMI SEL1	I	Illumination voltage setting signal input 1
15	ILLUMI SEL2	I	Illumination voltage setting signal input 2
16 to 22	NCO	O	Not used. (Open)
23	VCC5	—	Power supply pin (+3.3 V)
24	EED SIO	I/O	EEPROM bus serial data input/output
25	EED CKO	O	EEPROM bus serial clock output
26	AMP STB	O	Power AMP satandby signal output
27	LCD CE	O	LCD driver chip enable signal output
28	LCD SO	O	LCD driver serial data signal output
29	LCD SCK	O	LCD driver serial clock signal output
30	RDS ON	O	RDS ON signal output
31	RE IN0	I	Rotary encoder signal input 0
32	RE IN1	I	Rotary encoder signal input 1
33	I2C CKO	O	I2C bus serial clock signal output
34	I2C SIO	I/O	I2C bus serial data signal input/output
35	DAVDD	—	A/D converter power supply pin (+3.3 V)
36	AVRH	—	A/D converter external reference power supply pin (+3.3 V)
37	DAVSS	—	Ground pin
38	QUALITY	I	Noise detect signal input
39	VSM	I	S-meter voltage detect signal input
40	KEY IN1	I	Key signal input 1
41	KEY IN0	I	Key signal input 0
42	VSS	—	Ground pin
43	RC IN0	I	Rotary commander key signal input
44 to 48	NCO	O	Not used. (open)
49	MD0	I	Operation mode setting pin (Connect to VDD.)
50	MD1	I	Operation mode setting pin (Connect to VDD.)
51	MD2	I	Operation mode setting pin (Connect to VSS.)

Pin No.	Pin Name	I/O	Pin Description
52	KEY ACK	I	Key acknowledgment detect signal input
53	TU ATT IN	I	Tuner mute zero cross detect signal input
54	BU IN	I	Back-up power supply detect signal input
55	NCO	O	Not used. (Open)
56	DAVN	I	RDS data block synchronized detect signal input
57	NCO	O	Not used. (Open)
58	UNISI	I	SONY bus data signal input
59	UNI SO	O	SONY bus data signal output
60	UNI SCK	O	SONY bus clock signal output
61	611 SEL	I	Mechanism deck select signal input
62	WMA	I	WMA select signal input
63	NCO	O	Not used. (Open)
64	SIRCS	I	Remote control signal input
65 to 67	NCO	O	Not used. (Open)
68	FLASH W	I	Memory mode select signal input
69, 70	NCO	O	Not used. (Open)
71	$\overline{\text{RC IN1}}$	I	Rotary commander shift key signal input
72	$\overline{\text{ACC IN}}$	I	Accessory power supply detect signal input
73	$\overline{\text{TEST IN}}$	I	Test mode detect signal input
74	TEL ATT	I	Telephone attenuate detect signal input
75	NCO	O	Not used. (Open)
76	$\overline{\text{XKEY ON}}$	O	A/D converter power supply control signal output
77	$\overline{\text{RESET}}$	I	CPU reset signal input
78	NCO	O	Not used. (Open)
79	XOUT	O	Sub-clock output (32.768 kHz)
80	XIN	I	Sub-clock input (32.768 kHz)
81	VSS1	—	Ground pin
82	OSC IN	I	Main-clock input (3.68 MHz)
83	OSC OUT	O	Main-clock output (3.68 MHz)
84	VCC3	—	Power supply pin (+3.3 V)
85	DEMOSEL	I	DEMO select signal input
86	ATT	O	Audio mute control signal output
87	$\overline{\text{BUS ON}}$	O	Bus on signal output
88	$\overline{\text{SYS RST}}$	O	System reset signal output
89	EJECT OK SW	O	Eject OK signal output
90 to 92	NCO	O	Not used. (Open)
93	Z-MUTE	I	CD zero cross mute detect signal input
94 to 97	NCO	O	Not used. (Open)
98	CD ON	I	CD mechanism power control request signal input
99	CDM ON	I	CD mechanism deck power control request signal input
100	NCO	O	Not used. (Open)

4-2. FRONT PANEL SECTION

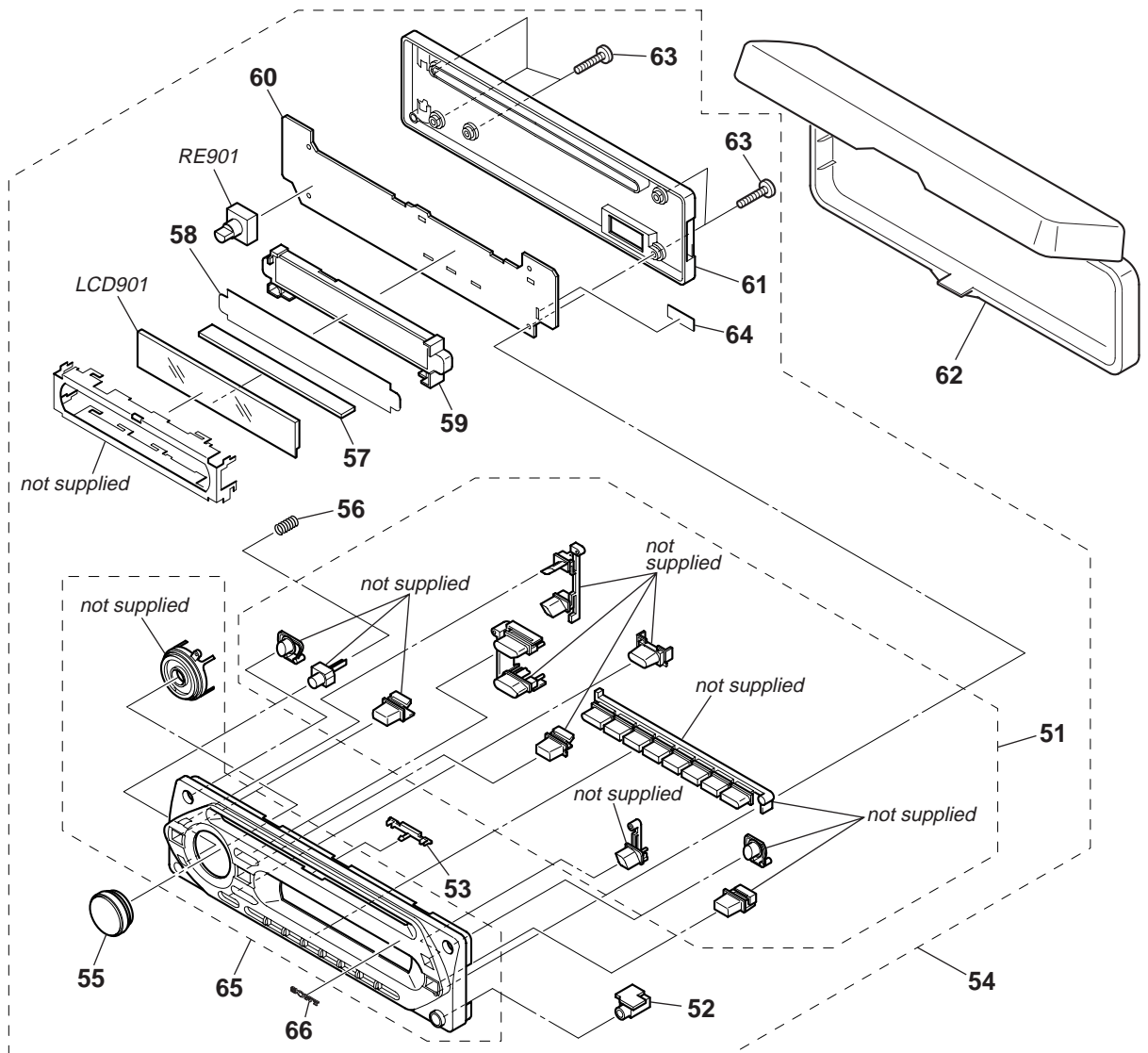

Ref. No.	Part No.	Description	Remark	Ref. No.	Part No.	Description	Remark
51	X-2067-610-1	BUTTON ASSY (S) (GT20W/GT200:US,CND/GT200E)		60	A-1134-484-A	KEY BOARD, COMPLETE (GT200:US,CND)	
51	X-2067-611-1	BUTTON ASSY (S) (GT200:AEP,UK)		60	A-1134-490-A	KEY BOARD, COMPLETE (GT20W)	
51	X-2067-612-1	BUTTON ASSY (S) (GT250S)		60	A-1134-499-A	KEY BOARD, COMPLETE (GT200:AEP,UK/GT200S/GT250S)	
51	X-2102-533-1	BUTTON ASSY (S) (GT200S)		60	A-1134-519-A	KEY BOARD, COMPLETE (GT200E)	
52	A-1134-211-A	JACK BOARD, COMPLETE		61	2-631-511-02	PANEL, FRONT BACK	
53	2-631-526-01	PLATE (CD), LIGHT GUIDE		62	X-2024-133-3	CASE ASSY (for FRONT PANEL) (EXCEPT US)	
54	A-1134-482-A	PANEL ASSY, FRONT (GT200:US,CND)		63	3-250-543-91	SCREW (+B P-TITE M2)	
54	A-1134-488-A	PANEL ASSY, FRONT (GT20W)		64	3-040-315-01	COVER (AC OUT)	
54	A-1134-503-A	PANEL ASSY, FRONT (GT250S)		65	X-2067-573-1	PANEL SUB ASSY, FRONT (GT200:US,CND)	
54	A-1134-510-A	PANEL ASSY, FRONT (GT200:AEP,UK)		65	X-2067-574-1	PANEL SUB ASSY, FRONT (GT20W)	
54	A-1134-516-A	PANEL ASSY, FRONT (GT200S)		65	X-2067-575-1	PANEL SUB ASSY, FRONT (GT200S)	
54	A-1134-517-A	PANEL ASSY, FRONT (GT200E)		65	X-2067-576-1	PANEL SUB ASSY, FRONT (GT250S)	
55	X-2102-730-1	KNOB (VOL) (SV) ASSY		65	X-2067-577-1	PANEL SUB ASSY, FRONT (GT200:AEP,UK)	
56	2-349-626-01	SPRING (RELEASE)		65	X-2067-578-1	PANEL SUB ASSY, FRONT (GT200E)	
57	1-780-199-11	CONDUCTIVE BOARD, CONNECTION		66	3-251-320-01	EMBLEM (NO. 2.5), SONY	
58	2-634-438-01	ILLUMINATOR (LCD)		LCD901	1-805-919-11	DISPLAY PANEL, LIQUID CRYSTAL (AEP,UK,E,MX)	
59	X-2067-569-1	HOLDER (LCD) ASSY		LCD901	1-805-920-11	DISPLAY PANEL, LIQUID CRYSTAL (US,CND)	
				RE901	1-478-474-12	ENCODER, ROTARY (PUSH SELECT/VOLUME)	

4-3. CD MECHANISM SECTION (1)
(MG-611WA-186//C)

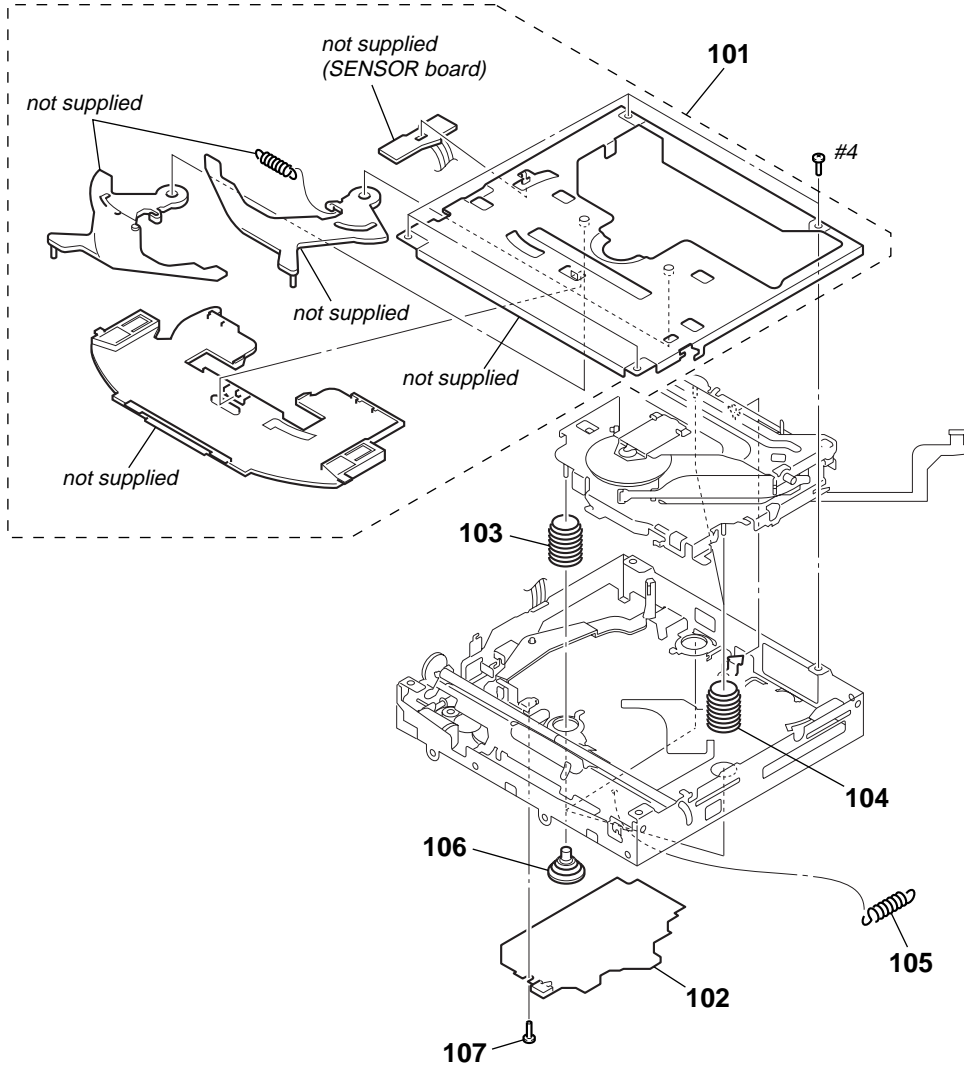

Ref. No.	Part No.	Description	Remark	Ref. No.	Part No.	Description	Remark
101	A-1088-624-A	CHASSIS (T) SUB ASSY		105	2-345-767-21	SPRING (KF60), TENSION	
102	A-1132-415-A	SERVO BOARD, COMPLETE		106	3-253-748-11	DAMPER (S)	
103	2-345-865-11	SPRING (DAMPER), COMPRESSION (BLACK)		107	3-352-758-31	SCREW (M1.7X2.5), TOOTHED LOCK	
104	2-345-865-01	SPRING (DAMPER), COMPRESSION (NATURAL)		#4	7-627-552-87	SCREW, PRECISION +P 1.7X2.2	

4-4. CD MECHANISM SECTION (2)
(MG-611WA-186//C)

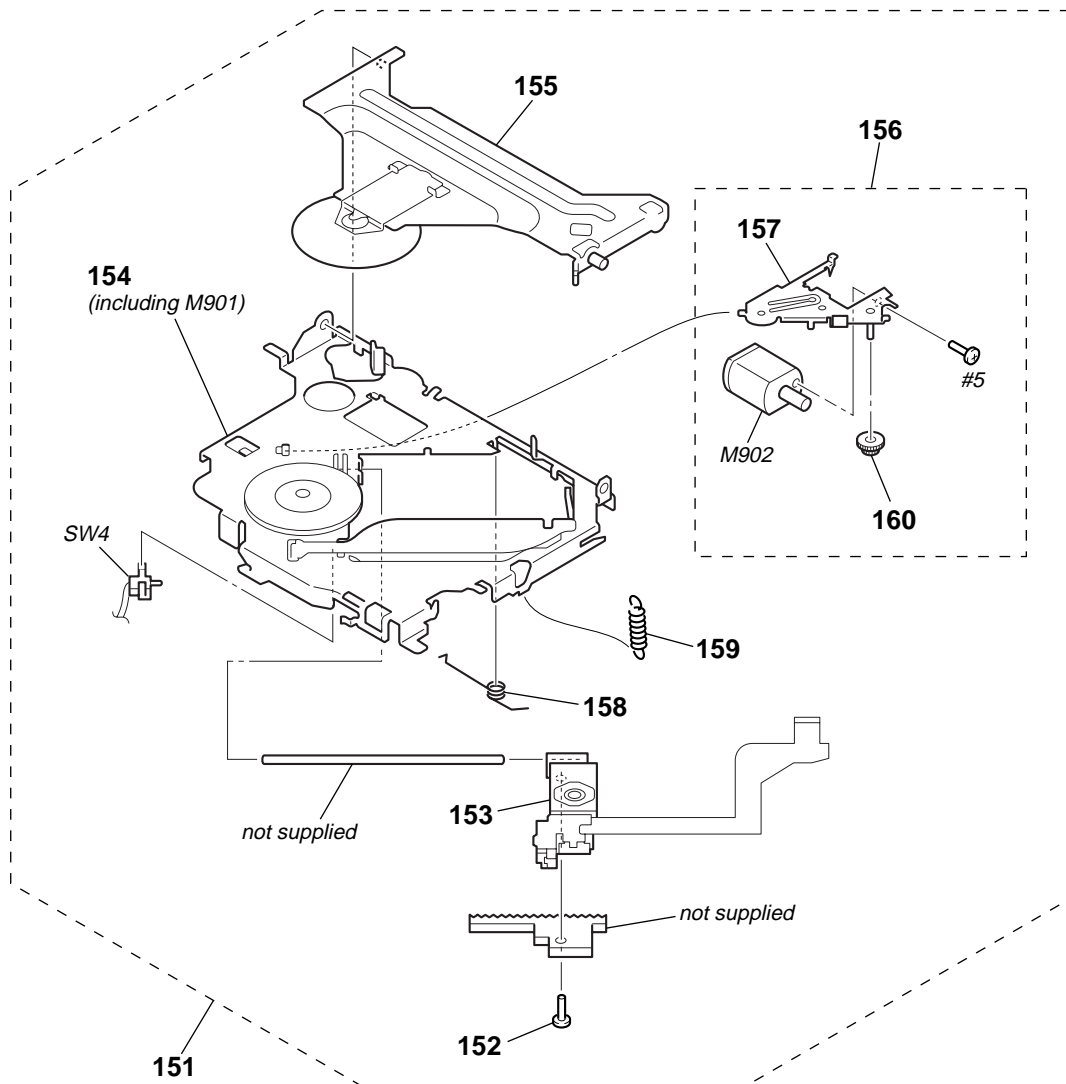

Ref. No.	Part No.	Description	Remark	Ref. No.	Part No.	Description	Remark
151	A-1088-612-A	CHASSIS (OP) COMPLETE ASSY		158	3-261-959-21	SPRING (SL), TORSION	
152	3-316-938-91	SCREW (B1.4X5), TAPPING		159	3-253-736-21	SPRING (CHKG), TENSION	
△ 153	8-820-207-12	OPTICAL PICK-UP (KSS1000E/K1RP)		160	3-253-742-21	WHEEL (SL), WORM	
154	A-1088-615-A	CHASSIS (OP) SUB ASSY (including M901)		M902	A-1088-614-A	MOTOR ASSY, SL (SLED)	
155	A-1088-616-A	ARM SUB ASSY, CHUCKING		SW4	1-786-339-11	SWITCH (M) (LIMIT)	
156	A-1088-613-A	LEVER (SL) SUB ASSY		#5	7-627-850-77	SCREW, PRECISION +P 1.4X1.8	
157	X-2024-784-3	LEVER (SL) ASSY					

4-5. CD MECHANISM SECTION (3)
(MG-611WA-186//C)

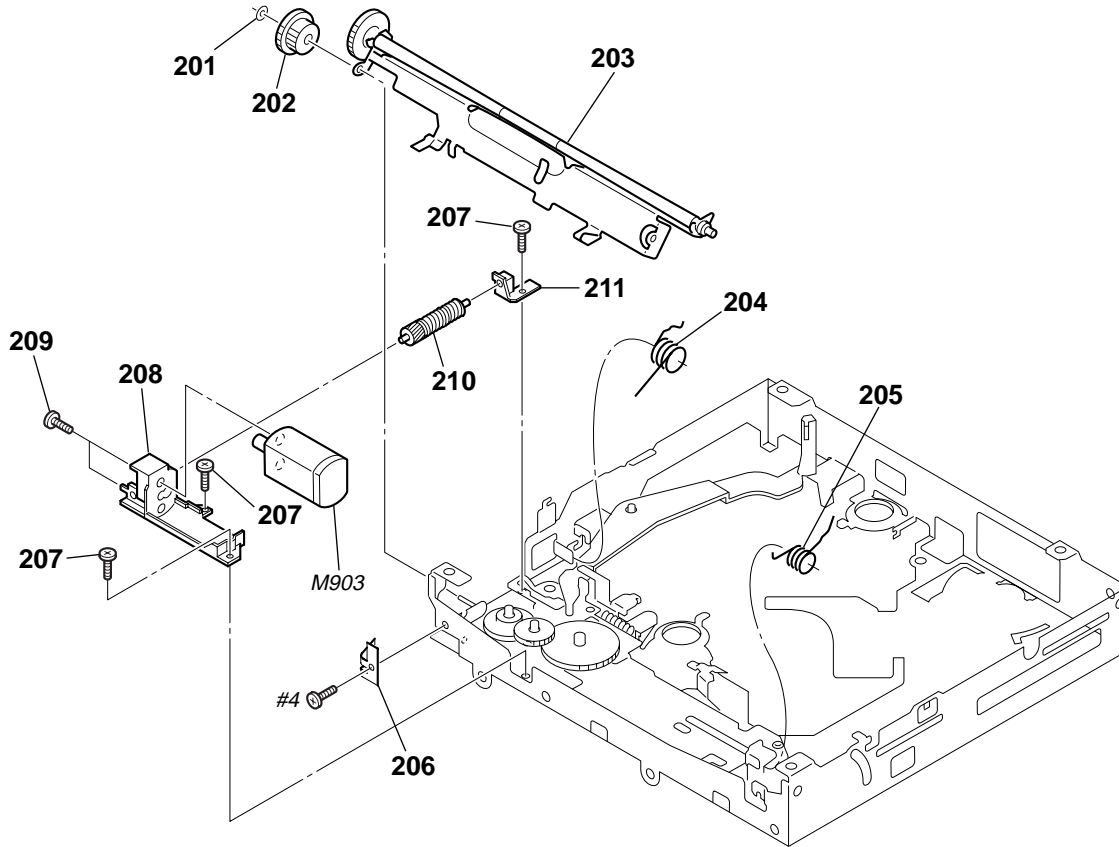

Ref. No.	Part No.	Description	Remark	Ref. No.	Part No.	Description	Remark
201	3-262-755-11	WASHER (1.1-2.5)		208	2-186-696-21	BRACKET (LEM-N)	
202	2-186-699-21	GEAR (RA1)		209	3-345-648-91	SCREW (M1.4), TOOTHED LOCK	
203	A-1088-618-A	ARM ASSY, ROLLER		210	A-1088-623-A	GEAR (LE) ASSY	
204	3-259-455-21	SPRING (RAL)		211	2-186-697-21	BEARING (LEB-N)	
205	3-253-713-21	SPRING (RAR)		M903	A-1088-622-A	MOTOR ASSY, LE (LOADING)	
206	3-259-469-21	SPRING (LE), LEAF		#4	7-627-552-87	SCREW, PRECISION +P 1.7X2.2	
207	2-134-636-51	SCREW (M1.7X2.5)					

4-6. CD MECHANISM SECTION (4)
(MG-611WA-186//C)

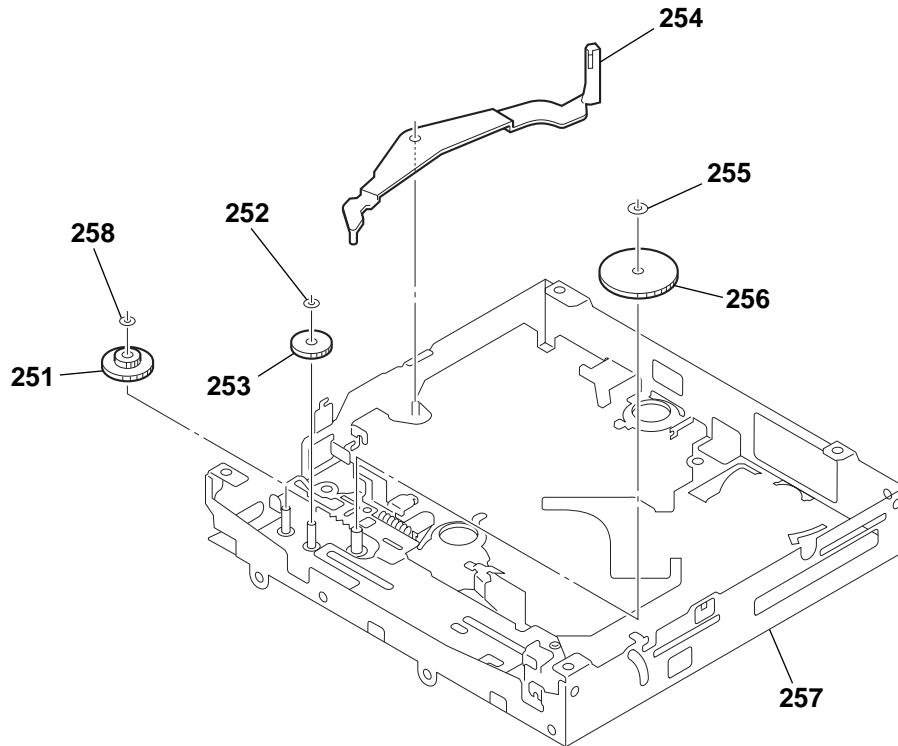

Ref. No.	Part No.	Description	Remark	Ref. No.	Part No.	Description	Remark
251	2-186-700-21	GEAR (CHK1)		255	3-899-829-01	WASHER (SLIT)	
252	3-344-223-01	WASHER		256	2-590-545-21	GEAR (LE2-M)	
253	3-259-470-23	GEAR (LE1)		257	A-1088-620-A	CHASSIS (M) BLOCK ASSY	
254	3-253-755-21	LEVER (D)		258	3-262-755-11	WASHER (1.1-2.5)	

CDX-GT20W/GT200/GT200E/GT200S/GT250S

SECTION 5

ELECTRICAL PARTS LIST

JACK **KEY**

NOTE:

- Due to standardization, replacements in the parts list may be different from the parts specified in the diagrams or the components used on the set.
- -XX and -X mean standardized parts, so they may have some difference from the original one.
- RESISTORS
All resistors are in ohms.
METAL: Metal-film resistor.
METAL OXIDE: Metal oxide-film resistor.
F: nonflammable

- Items marked “*” are not stocked since they are seldom required for routine service. Some delay should be anticipated when ordering these items.
- SEMICONDUCTORS
In each case, u : μ , for example:
uA.. : μ A.. uPA.. : μ PA..
uPB.. : μ PB.. uPC.. : μ PC.. uPD.. : μ PD..
- CAPACITORS
uF : μ F
- COILS
uH : μ H

The components identified by mark Δ or dotted line with mark Δ are critical for safety. Replace only with part number specified.

Les composants identifiés par une marque Δ sont critiques pour la sécurité. Ne les remplacer que par une pièce portant le numéro spécifié.

When indicating parts by reference number, please include the board.

Ref. No.	Part No.	Description	Remark
	A-1134-211-A	JACK BOARD, COMPLETE *****	
		< JACK >	
J901	1-819-732-11	JACK (SMALL TYPE) (DIA. 3.5) (AUX) *****	
	A-1134-484-A	KEY BOARD, COMPLETE (GT200:US,CND)	
	A-1134-490-A	KEY BOARD, COMPLETE (GT20W)	
	A-1134-499-A	KEY BOARD, COMPLETE (GT200:AEP,UK/GT200S/GT250S)	
	A-1134-519-A	KEY BOARD, COMPLETE (GT200E) *****	
		< CAPACITOR >	
C921	1-163-031-11	CERAMIC CHIP 0.01uF	50V
C922	1-163-031-11	CERAMIC CHIP 0.01uF	50V
C971	1-107-826-11	CERAMIC CHIP 0.1uF	10% 16V
C981	1-107-826-11	CERAMIC CHIP 0.1uF	10% 16V
C983	1-107-826-11	CERAMIC CHIP 0.1uF	10% 16V
C984	1-107-826-11	CERAMIC CHIP 0.1uF	10% 16V
C985	1-131-664-11	CERAMIC CHIP 0.15uF	10% 10V
C986	1-127-715-11	CERAMIC CHIP 0.22uF	10% 16V
		< CONNECTOR >	
CN901	1-819-758-11	PLUG, CONNECTOR 15P	
		< DIODE >	
D901	6-500-886-01	DIODE RSA6.1ENTR	
D903	6-501-180-01	DIODE UDZW-TE17-18B	
D981	6-501-167-01	DIODE UDZW-TE17-5.1B	
D982	6-501-193-01	DIODE 1SS355WTE-17	
		< JUMPER RESISTOR >	
FB901	1-216-864-11	SHORT CHIP 0	
FB902	1-216-864-11	SHORT CHIP 0	
FB903	1-216-295-11	SHORT CHIP 0	
		< IC >	
IC901	6-707-063-01	IC LC75826WH-US-E	
IC971	6-600-163-01	IC RS-770 (IR)	

Ref. No.	Part No.	Description	Remark
		< DIODE >	
LED932	6-501-339-01	LED NESW505CT-AST (LCD BACK LIGHT)	
LED941	6-500-450-01	LED CL-195SR-CD-T (RING ILLUMINATION) (GT200/GT200S/GT250S)	
LED941	6-500-510-01	LED CL-195PG-CD-T (RING ILLUMINATION) (GT20W/GT200E)	
LED942	6-500-450-01	LED CL-195SR-CD-T (RING ILLUMINATION) (GT200/GT200S/GT250S)	
LED942	6-500-510-01	LED CL-195PG-CD-T (RING ILLUMINATION) (GT20W/GT200E)	
LED943	6-500-450-01	LED CL-195SR-CD-T (RING ILLUMINATION) (GT200/GT200S/GT250S)	
LED943	6-500-510-01	LED CL-195PG-CD-T (RING ILLUMINATION) (GT20W/GT200E)	
LED944	6-500-450-01	LED CL-195SR-CD-T (RING ILLUMINATION) (GT200/GT200S/GT250S)	
LED944	6-500-510-01	LED CL-195PG-CD-T (RING ILLUMINATION) (GT20W/GT200E)	
LED951	6-500-450-01	LED CL-195SR-CD-T (DISC SLOT) (GT200/GT200S/GT250S)	
LED951	6-500-510-01	LED CL-195PG-CD-T (DISC SLOT) (GT20W/GT200E)	
		< SWITCH >	
LSW901	1-786-805-11	SWITCH, TACTILE (WITH LED) (\blacktriangle) (GT200/GT200S/GT250S)	
LSW901	1-786-806-11	SWITCH, TACTILE (WITH LED) (\blacktriangle) (GT20W/GT200E)	
LSW902	1-786-805-11	SWITCH, TACTILE (WITH LED) (OFF) (GT200/GT200S/GT250S)	
LSW902	1-786-806-11	SWITCH, TACTILE (WITH LED) (OFF) (GT20W/GT200E)	
LSW903	1-786-805-11	SWITCH, TACTILE (WITH LED) (SOURCE) (GT200/GT200S/GT250S)	
LSW903	1-786-806-11	SWITCH, TACTILE (WITH LED) (SOURCE) (GT20W/GT200E)	
LSW904	1-786-805-11	SWITCH, TACTILE (WITH LED) (GP/ALBM -) (GT200/GT200S/GT250S)	
LSW904	1-786-806-11	SWITCH, TACTILE (WITH LED) (GP/ALBM -) (GT20W/GT200E)	
LSW906	1-786-805-11	SWITCH, TACTILE (WITH LED) (GP/ALBM +) (GT200/GT200S/GT250S)	

Ref. No.	Part No.	Description	Remark	Ref. No.	Part No.	Description	Remark
LSW906	1-786-806-11	SWITCH, TACTILE (WITH LED) (GP/ALBM +) (GT20W/GT200E)		LSW920	1-786-806-11	SWITCH, TACTILE (WITH LED) (DSPL/DIM) (GT20W/GT200E)	
LSW907	1-786-805-11	SWITCH, TACTILE (WITH LED) (●/SCRL) (GT200:US,CND/GT250S)		< TRANSISTOR >			
LSW907	1-786-805-11	SWITCH, TACTILE (WITH LED) (●/AF/TA) (GT200:AEP,UK/GT200S)		Q931	8-729-027-44	TRANSISTOR	DTC114TKA-T146
LSW907	1-786-806-11	SWITCH, TACTILE (WITH LED) (●/SCRL) (GT20W/GT200E)		Q932	8-729-027-58	TRANSISTOR	DTC143ZKA-T146
LSW908	1-786-805-11	SWITCH, TACTILE (WITH LED) (EQ3) (GT200/GT200S/GT250S)		< RESISTOR >			
LSW908	1-786-806-11	SWITCH, TACTILE (WITH LED) (EQ3) (GT20W/GT200E)		R901	1-216-819-11	METAL CHIP	680 5% 1/10W
LSW909	1-786-805-11	SWITCH, TACTILE (WITH LED) (▶▶▶▶ SEEK +) (GT200/GT200S/GT250S)		R902	1-216-819-11	METAL CHIP	680 5% 1/10W
LSW909	1-786-806-11	SWITCH, TACTILE (WITH LED) (▶▶▶▶ SEEK +) (GT20W/GT200E)		R903	1-216-819-11	METAL CHIP	680 5% 1/10W
LSW910	1-786-805-11	SWITCH, TACTILE (WITH LED) (◀◀◀◀ SEEK -) (GT200/GT200S/GT250S)		R904	1-216-821-11	METAL CHIP	1K 5% 1/10W
LSW910	1-786-806-11	SWITCH, TACTILE (WITH LED) (◀◀◀◀ SEEK -) (GT20W/GT200E)		R905	1-216-823-11	METAL CHIP	1.5K 5% 1/10W
LSW911	1-786-805-11	SWITCH, TACTILE (WITH LED) (BTM) (GT200:US,CND/GT250S)		R906	1-216-819-11	METAL CHIP	680 5% 1/10W
LSW911	1-786-805-11	SWITCH, TACTILE (WITH LED) (PTY) (GT200:AEP,UK/GT200S)		R907	1-216-819-11	METAL CHIP	680 5% 1/10W
LSW911	1-786-806-11	SWITCH, TACTILE (WITH LED) (BTM) (GT20W/GT200E)		R908	1-216-819-11	METAL CHIP	680 5% 1/10W
LSW912	1-786-805-11	SWITCH, TACTILE (WITH LED) (MODE) (GT200/GT200S/GT250S)		R909	1-216-821-11	METAL CHIP	1K 5% 1/10W
LSW912	1-786-806-11	SWITCH, TACTILE (WITH LED) (MODE) (GT20W/GT200E)		R910	1-216-823-11	METAL CHIP	1.5K 5% 1/10W
LSW913	1-786-805-11	SWITCH, TACTILE (WITH LED) (1) (GT200/GT200S/GT250S)		R911	1-216-823-11	METAL CHIP	1.5K 5% 1/10W
LSW913	1-786-806-11	SWITCH, TACTILE (WITH LED) (1) (GT20W/GT200E)		R912	1-216-825-11	METAL CHIP	2.2K 5% 1/10W
LSW914	1-786-805-11	SWITCH, TACTILE (WITH LED) (2) (GT200/GT200S/GT250S)		R913	1-216-827-11	METAL CHIP	3.3K 5% 1/10W
LSW914	1-786-806-11	SWITCH, TACTILE (WITH LED) (2) (GT20W/GT200E)		R914	1-216-829-11	METAL CHIP	4.7K 5% 1/10W
LSW915	1-786-805-11	SWITCH, TACTILE (WITH LED) (3/REP) (GT200/GT200S/GT250S)		R915	1-218-867-11	METAL CHIP	6.8K 0.5% 1/10W
LSW915	1-786-806-11	SWITCH, TACTILE (WITH LED) (3/REP) (GT20W/GT200E)		R916	1-216-833-11	METAL CHIP	10K 5% 1/10W
LSW916	1-786-805-11	SWITCH, TACTILE (WITH LED) (4/SHUF) (GT200/GT200S/GT250S)		R917	1-216-835-11	METAL CHIP	15K 5% 1/10W
LSW916	1-786-806-11	SWITCH, TACTILE (WITH LED) (4/SHUF) (GT20W/GT200E)		R918	1-216-837-11	METAL CHIP	22K 5% 1/10W
LSW917	1-786-805-11	SWITCH, TACTILE (WITH LED) (5) (GT200/GT200S/GT250S)		R921	1-216-025-11	RES-CHIP	100 5% 1/10W
LSW917	1-786-806-11	SWITCH, TACTILE (WITH LED) (5) (GT20W/GT200E)		R922	1-216-025-11	RES-CHIP	100 5% 1/10W
LSW918	1-786-805-11	SWITCH, TACTILE (WITH LED) (6/PAUSE) (GT200/GT200S/GT250S)		R931	1-216-812-11	METAL CHIP	180 5% 1/10W
LSW918	1-786-806-11	SWITCH, TACTILE (WITH LED) (6/PAUSE) (GT20W/GT200E)		R932	1-216-812-11	METAL CHIP	180 5% 1/10W
LSW919	1-786-805-11	SWITCH, TACTILE (WITH LED) (SENS) (GT200:US,CND/GT250S)		R933	1-216-812-11	METAL CHIP	180 5% 1/10W
LSW919	1-786-805-11	SWITCH, TACTILE (WITH LED) (SENS/BTM) (GT200:AEP,UK/GT200S)		R934	1-216-822-11	METAL CHIP	1.2K 5% 1/10W
LSW919	1-786-806-11	SWITCH, TACTILE (WITH LED) (SENS) (GT20W/GT200E)		R941	1-216-810-11	METAL CHIP	120 5% 1/10W (GT20W/GT200E)
LSW920	1-786-805-11	SWITCH, TACTILE (WITH LED) (DSPL/DIM) (GT200/GT200S/GT250S)		R941	1-216-813-11	METAL CHIP	220 5% 1/10W (GT200/GT200S/GT250S)
				R942	1-216-810-11	METAL CHIP	120 5% 1/10W (GT20W/GT200E)
				R942	1-216-813-11	METAL CHIP	220 5% 1/10W (GT200/GT200S/GT250S)
				R944	1-216-811-11	METAL CHIP	150 5% 1/10W
				R945	1-216-810-11	METAL CHIP	120 5% 1/10W (GT20W/GT200E)
				R945	1-216-812-11	METAL CHIP	180 5% 1/10W (GT200/GT200S/GT250S)
				R946	1-216-807-11	METAL CHIP	68 5% 1/10W (GT20W/GT200E)
				R946	1-216-809-11	METAL CHIP	100 5% 1/10W (GT200/GT200S/GT250S)
				R947	1-216-807-11	METAL CHIP	68 5% 1/10W (GT20W/GT200E)
				R947	1-216-809-11	METAL CHIP	100 5% 1/10W (GT200/GT200S/GT250S)
				R948	1-216-811-11	METAL CHIP	150 5% 1/10W
				R949	1-216-810-11	METAL CHIP	120 5% 1/10W (GT20W/GT200E)
				R949	1-216-812-11	METAL CHIP	180 5% 1/10W (GT200/GT200S/GT250S)
				R950	1-216-807-11	METAL CHIP	68 5% 1/10W (GT20W/GT200E)

CDX-GT20W/GT200/GT200E/GT200S/GT250S

KEY MAIN

Ref. No.	Part No.	Description	Remark
R950	1-216-809-11	METAL CHIP	100 5% 1/10W (GT200/GT200S/GT250S)
R951	1-216-807-11	METAL CHIP	68 5% 1/10W (GT20W/GT200E)
R951	1-216-809-11	METAL CHIP	100 5% 1/10W (GT200/GT200S/GT250S)
R952	1-216-810-11	METAL CHIP	120 5% 1/10W (GT20W/GT200E)
R952	1-216-811-11	METAL CHIP	150 5% 1/10W (GT200/GT200S/GT250S)
R953	1-216-811-11	METAL CHIP	150 5% 1/10W
R954	1-216-810-11	METAL CHIP	120 5% 1/10W (GT20W/GT200E)
R954	1-216-811-11	METAL CHIP	150 5% 1/10W (GT200/GT200S/GT250S)
R955	1-216-811-11	METAL CHIP	150 5% 1/10W
R956	1-216-810-11	METAL CHIP	120 5% 1/10W (GT20W/GT200E)
R956	1-216-812-11	METAL CHIP	180 5% 1/10W (GT200/GT200S/GT250S)
R957	1-216-811-11	METAL CHIP	150 5% 1/10W
R958	1-216-810-11	METAL CHIP	120 5% 1/10W (GT20W/GT200E)
R958	1-216-812-11	METAL CHIP	180 5% 1/10W (GT200/GT200S/GT250S)
R959	1-216-811-11	METAL CHIP	150 5% 1/10W
R960	1-216-810-11	METAL CHIP	120 5% 1/10W (GT20W/GT200E)
R960	1-216-812-11	METAL CHIP	180 5% 1/10W (GT200/GT200S/GT250S)
R961	1-216-811-11	METAL CHIP	150 5% 1/10W
R962	1-216-810-11	METAL CHIP	120 5% 1/10W (GT20W/GT200E)
R962	1-216-812-11	METAL CHIP	180 5% 1/10W (GT200/GT200S/GT250S)
R963	1-216-811-11	METAL CHIP	150 5% 1/10W
R964	1-216-810-11	METAL CHIP	120 5% 1/10W (GT20W/GT200E)
R964	1-216-812-11	METAL CHIP	180 5% 1/10W (GT200/GT200S/GT250S)
R972	1-216-809-11	METAL CHIP	100 5% 1/10W
R974	1-216-864-11	SHORT CHIP	0
R976	1-216-864-11	SHORT CHIP	0
R977	1-216-809-11	METAL CHIP	100 5% 1/10W
R978	1-216-809-11	METAL CHIP	100 5% 1/10W
R979	1-216-809-11	METAL CHIP	100 5% 1/10W
R981	1-216-811-11	METAL CHIP	150 5% 1/10W
R982	1-216-811-11	METAL CHIP	150 5% 1/10W
R984	1-216-821-11	METAL CHIP	1K 5% 1/10W
R985	1-216-821-11	METAL CHIP	1K 5% 1/10W
R986	1-216-821-11	METAL CHIP	1K 5% 1/10W
R987	1-216-857-11	METAL CHIP	1M 5% 1/10W
R991	1-216-864-11	SHORT CHIP	0

Ref. No.	Part No.	Description	Remark
	A-1134-479-A	MAIN BOARD, COMPLETE (US,CND)	
	A-1134-494-A	MAIN BOARD, COMPLETE (GT250S)	
	A-1134-507-A	MAIN BOARD, COMPLETE (GT200:AEP,UK/GT200S)	
	A-1134-514-A	MAIN BOARD, COMPLETE (GT200E) *****	
	7-621-284-40	SCREW +P 2.6X10	
	7-685-134-19	SCREW +P 2.6X8 TYPE2 NON-SLIT	
	7-685-793-09	SCREW +PTT 2.6X8 (S)	
	7-685-795-09	SCREW +PTT 2.6X12 (S)	
		< CAPACITOR >	
C1	1-162-964-11	CERAMIC CHIP 0.001uF 10% 50V (GT200:AEP,UK/GT200S)	
C2	1-162-964-11	CERAMIC CHIP 0.001uF 10% 50V (GT200:AEP,UK/GT200S)	
C3	1-126-963-11	ELECT 4.7uF 20% 50V (GT200:AEP,UK/GT200S)	
C4	1-126-947-11	ELECT 47uF 20% 35V	
C5	1-126-947-11	ELECT 47uF 20% 35V	
C6	1-162-970-11	CERAMIC CHIP 0.01uF 10% 25V	
C7	1-162-970-11	CERAMIC CHIP 0.01uF 10% 25V	
C12	1-162-970-11	CERAMIC CHIP 0.01uF 10% 25V	
C13	1-162-970-11	CERAMIC CHIP 0.01uF 10% 25V	
C51	1-126-947-11	ELECT 47uF 20% 35V (GT200:AEP,UK/GT200S)	
C53	1-107-826-11	CERAMIC CHIP 0.1uF 10% 16V (GT200:AEP,UK/GT200S)	
C54	1-107-826-11	CERAMIC CHIP 0.1uF 10% 16V (GT200:AEP,UK/GT200S)	
C55	1-107-826-11	CERAMIC CHIP 0.1uF 10% 16V (GT200:AEP,UK/GT200S)	
C56	1-107-826-11	CERAMIC CHIP 0.1uF 10% 16V (GT200:AEP,UK/GT200S)	
C57	1-107-826-11	CERAMIC CHIP 0.1uF 10% 16V (GT200:AEP,UK/GT200S)	
C58	1-107-826-11	CERAMIC CHIP 0.1uF 10% 16V (GT200:AEP,UK/GT200S)	
C59	1-164-237-11	CERAMIC CHIP 16PF 5% 50V (GT200:AEP,UK/GT200S)	
C60	1-162-916-11	CERAMIC CHIP 12PF 5% 50V (GT200:AEP,UK/GT200S)	
C62	1-162-959-11	CERAMIC CHIP 330PF 5% 50V (GT200:AEP,UK/GT200S)	
C301	1-128-551-11	ELECT 22uF 20% 63V	
C302	1-104-665-11	ELECT 100uF 20% 25V	
C305	1-104-665-11	ELECT 100uF 20% 25V	
C306	1-162-970-11	CERAMIC CHIP 0.01uF 10% 25V	
C308	1-162-970-11	CERAMIC CHIP 0.01uF 10% 25V	
C309	1-162-966-11	CERAMIC CHIP 0.0022uF 10% 50V	
C310	1-162-966-11	CERAMIC CHIP 0.0022uF 10% 50V	
C312	1-162-970-11	CERAMIC CHIP 0.01uF 10% 25V	
C343	1-162-970-11	CERAMIC CHIP 0.01uF 10% 25V	
C401	1-126-964-11	ELECT 10uF 20% 50V	
C404	1-127-715-11	CERAMIC CHIP 0.22uF 10% 16V	
C405	1-127-715-11	CERAMIC CHIP 0.22uF 10% 16V	
C406	1-126-960-11	ELECT 1uF 20% 50V	
C407	1-126-960-11	ELECT 1uF 20% 50V	
C410	1-162-923-11	CERAMIC CHIP 47PF 5% 50V	
C411	1-162-923-11	CERAMIC CHIP 47PF 5% 50V	

Ref. No.	Part No.	Description	Remark	Ref. No.	Part No.	Description	Remark
C412	1-126-934-11	ELECT	220uF 20% 16V	C776	1-162-964-11	CERAMIC CHIP 0.001uF 10% 50V	
C413	1-162-970-11	CERAMIC CHIP	0.01uF 10% 25V	C901	1-109-982-11	CERAMIC CHIP 1uF 10% 10V	
C431	1-126-964-11	ELECT	10uF 20% 50V	C902	1-109-982-11	CERAMIC CHIP 1uF 10% 10V	
C432	1-165-908-11	CERAMIC CHIP	1uF 10% 10V	C903	1-126-961-11	ELECT 2.2uF 20% 50V	
C435	1-165-908-11	CERAMIC CHIP	1uF 10% 10V	C905	1-162-970-11	CERAMIC CHIP 0.01uF 10% 25V	
C441	1-126-964-11	ELECT	10uF 20% 50V	C917	1-163-017-00	CERAMIC CHIP 0.0047uF 10% 50V	
C442	1-165-908-11	CERAMIC CHIP	1uF 10% 10V	C918	1-163-017-00	CERAMIC CHIP 0.0047uF 10% 50V	
C445	1-165-908-11	CERAMIC CHIP	1uF 10% 10V			< CONNECTOR >	
C451	1-126-964-11	ELECT	10uF 20% 50V	CN601	1-774-701-21	PIN, CONNECTOR 16P	
C452	1-165-908-11	CERAMIC CHIP	1uF 10% 10V	CN701	1-819-773-11	SOCKET, CONNECTOR 15P	
C455	1-165-908-11	CERAMIC CHIP	1uF 10% 10V	CNP301	1-817-536-11	CONNECTOR, BOARD TO BOARD 28P	
C461	1-126-964-11	ELECT	10uF 20% 50V			< DIODE >	
C462	1-165-908-11	CERAMIC CHIP	1uF 10% 10V	D1	6-501-168-01	DIODE UDZW-TE17-5.6B	
C465	1-165-908-11	CERAMIC CHIP	1uF 10% 10V	D479	6-501-193-01	DIODE 1SS355WTE-17	
C471	1-126-964-11	ELECT	10uF 20% 50V	D502	8-719-060-48	DIODE RB751V-40TE-17	
C474	1-163-251-11	CERAMIC CHIP	100PF 5% 50V	D503	6-501-193-01	DIODE 1SS355WTE-17	
C479	1-126-947-11	ELECT	47uF 20% 35V	D510	6-501-013-01	DIODE BAT54ALT1G	
C481	1-126-964-11	ELECT	10uF 20% 50V	D511	6-500-335-01	DIODE MC2838-T112-1	
C484	1-163-251-11	CERAMIC CHIP	100PF 5% 50V	D512	6-501-051-01	DIODE BAT54CLT1G	
C501	1-162-970-11	CERAMIC CHIP	0.01uF 10% 25V	D580	6-501-171-01	DIODE UDZW-TE17-7.5B	
C502	1-162-964-11	CERAMIC CHIP	0.001uF 10% 50V	D581	6-501-180-01	DIODE UDZW-TE17-18B	
C503	1-104-665-11	ELECT	100uF 20% 25V	D601	8-719-049-38	DIODE 1N5404TU	
C504	1-162-970-11	CERAMIC CHIP	0.01uF 10% 25V	D609	6-501-170-01	DIODE UDZW-TE17-6.8B	
C507	1-162-917-11	CERAMIC CHIP	15PF 5% 50V	D617	6-501-180-01	DIODE UDZW-TE17-18B	
C508	1-162-917-11	CERAMIC CHIP	15PF 5% 50V	D651	6-501-180-01	DIODE UDZW-TE17-18B (AEP,UK)	
C509	1-162-966-11	CERAMIC CHIP	0.0022uF 10% 50V	D719	6-501-180-01	DIODE UDZW-TE17-18B	
C510	1-162-970-11	CERAMIC CHIP	0.01uF 10% 25V	D751	6-500-522-01	DIODE 10EDB40-TA1B2	
C511	1-104-665-11	ELECT	100uF 20% 25V	D752	6-500-522-01	DIODE 10EDB40-TA1B2	
C512	1-162-964-11	CERAMIC CHIP	0.001uF 10% 50V	D753	6-500-522-01	DIODE 10EDB40-TA1B2	
C513	1-162-964-11	CERAMIC CHIP	0.001uF 10% 50V	D754	6-500-522-01	DIODE 10EDB40-TA1B2	
C514	1-162-964-11	CERAMIC CHIP	0.001uF 10% 50V	D755	6-500-522-01	DIODE 10EDB40-TA1B2	
C516	1-162-964-11	CERAMIC CHIP	0.001uF 10% 50V	D756	6-500-522-01	DIODE 10EDB40-TA1B2	
C516	1-216-864-11	SHORT CHIP	0	D757	6-500-522-01	DIODE 10EDB40-TA1B2	
			(GT200:AEP,UK/GT200S)	D758	6-500-522-01	DIODE 10EDB40-TA1B2	
			(GT20W/GT200:US,CND/GT200E/GT250S)	D759	6-500-522-01	DIODE 10EDB40-TA1B2	
C519	1-107-826-11	CERAMIC CHIP	0.1uF 10% 16V	D760	6-500-522-01	DIODE 10EDB40-TA1B2	
C601	1-131-868-81	ELECT	3300uF 20% 16V	D761	6-500-522-01	DIODE 10EDB40-TA1B2	
C602	1-165-319-11	CERAMIC CHIP	0.1uF 50V	D762	6-500-522-01	DIODE 10EDB40-TA1B2	
C617	1-163-009-11	CERAMIC CHIP	0.001uF 10% 50V	D903	6-501-170-01	DIODE UDZW-TE17-6.8B	
C618	1-163-009-11	CERAMIC CHIP	0.001uF 10% 50V			< FERRITE BEAD >	
C622	1-126-916-11	ELECT	1000uF 20% 6.3V	FB1	1-500-245-11	INDUCTOR, FERRITE BEAD	
C623	1-126-916-11	ELECT	1000uF 20% 6.3V	FB302	1-216-864-11	SHORT CHIP 0	
C631	1-126-960-11	ELECT	1uF 20% 50V	FB303	1-216-864-11	SHORT CHIP 0	
C750	1-115-340-11	CERAMIC CHIP	0.22uF 10% 25V	FB304	1-216-295-11	SHORT CHIP 0	
C751	1-115-340-11	CERAMIC CHIP	0.22uF 10% 25V	FB305	1-216-295-11	SHORT CHIP 0	
C753	1-128-551-11	ELECT	22uF 20% 63V	FB307	1-216-864-11	SHORT CHIP 0	
C754	1-126-961-11	ELECT	2.2uF 20% 50V	FB308	1-216-295-11	SHORT CHIP 0	
C755	1-162-964-11	CERAMIC CHIP	0.001uF 10% 50V	FB309	1-216-864-11	SHORT CHIP 0	
C756	1-127-715-11	CERAMIC CHIP	0.22uF 10% 16V	FB310	1-216-864-11	SHORT CHIP 0	
C758	1-126-964-11	ELECT	10uF 20% 50V	FB410	1-216-864-11	SHORT CHIP 0	
C763	1-127-715-11	CERAMIC CHIP	0.22uF 10% 16V			(GT20W/GT200:US,CND/GT200E/GT250S)	
C764	1-115-340-11	CERAMIC CHIP	0.22uF 10% 25V	FB410	1-414-595-11	INDUCTOR, FERRITE BEAD	
C765	1-115-340-11	CERAMIC CHIP	0.22uF 10% 25V			(GT200:AEP,UK/GT200S)	
C769	1-127-715-11	CERAMIC CHIP	0.22uF 10% 16V	FB411	1-216-864-11	SHORT CHIP 0	
C770	1-127-715-11	CERAMIC CHIP	0.22uF 10% 16V			(GT20W/GT200:US,CND/GT200E/GT250S)	
C771	1-127-715-11	CERAMIC CHIP	0.22uF 10% 16V				
C774	1-115-340-11	CERAMIC CHIP	0.22uF 10% 25V				
C775	1-115-340-11	CERAMIC CHIP	0.22uF 10% 25V				

CDX-GT20W/GT200/GT200E/GT200S/GT250S

MAIN

Ref. No.	Part No.	Description	Remark	Ref. No.	Part No.	Description	Remark
FB411	1-414-595-11	INDUCTOR, FERRITE BEAD (GT200:AEP,UK/GT200S)		Q580	8-729-027-43	TRANSISTOR DTC114EKA-T146	
FB501	1-216-295-11	SHORT CHIP 0		Q581	1-801-806-11	TRANSISTOR DTC144EKA	
FB603	1-216-295-11	SHORT CHIP 0		Q582	8-729-120-28	TRANSISTOR 2SC1623-L5L6	
FB604	1-500-245-11	INDUCTOR, FERRITE BEAD		Q631	8-729-120-28	TRANSISTOR 2SC1623-L5L6	
FB605	1-216-864-11	SHORT CHIP 0		Q651	8-729-120-28	TRANSISTOR 2SC1623-L5L6 (AEP,UK)	
FB606	1-216-864-11	SHORT CHIP 0		Q664	8-729-027-23	TRANSISTOR DTA114EKA-T146	
		< FUSE >				< RESISTOR >	
FU601	1-532-877-11	FUSE (BLADE TYPE) (AUTO FUSE) 10A		R1	1-216-821-11	METAL CHIP 1K 5% 1/10W	
		< IC >		R2	1-414-595-11	INDUCTOR, FERRITE BEAD	
IC51	6-803-747-01	IC TDA7333013TR (GT200:AEP,UK/GT200S)		R3	1-414-595-11	INDUCTOR, FERRITE BEAD	
IC401	6-708-880-01	IC BD3806AFS-E2		R4	1-216-839-11	METAL CHIP 33K 5% 1/10W	
IC501	6-806-031-01	IC MB90487APF-G-155E1		R5	1-216-843-11	METAL CHIP 68K 5% 1/10W	
IC602	8-759-659-13	IC PST3428UL		R6	1-216-839-11	METAL CHIP 33K 5% 1/10W (GT200:AEP,UK/GT200S)	
IC750	6-705-360-02	IC TDA8588BJ/N2/R1		R7	1-216-843-11	METAL CHIP 68K 5% 1/10W (GT200:AEP,UK/GT200S)	
IC901	8-759-681-42	IC NJM12902V(TE2)		R8	1-216-839-11	METAL CHIP 33K 5% 1/10W (GT200:AEP,UK/GT200S)	
		< JACK >		R9	1-216-843-11	METAL CHIP 68K 5% 1/10W (GT200:AEP,UK/GT200S)	
J1	1-815-185-13	JACK (ANTENNA)		R12	1-414-595-11	INDUCTOR, FERRITE BEAD	
J330	1-774-698-11	JACK, PIN 2P (AUDIO OUT REAR)		R13	1-414-595-11	INDUCTOR, FERRITE BEAD	
		< JUMPER RESISTOR >		R29	1-216-809-11	METAL CHIP 100 5% 1/10W (GT200:AEP,UK/GT200S)	
JC1	1-216-864-11	SHORT CHIP 0		R51	1-216-797-11	METAL CHIP 10 5% 1/10W (GT200:AEP,UK/GT200S)	
JC501	1-216-864-11	SHORT CHIP 0		R52	1-216-803-11	METAL CHIP 33 5% 1/10W (GT200:AEP,UK/GT200S)	
JC504	1-216-864-11	SHORT CHIP 0		R53	1-414-595-11	INDUCTOR, FERRITE BEAD (GT200:AEP,UK/GT200S)	
JC527	1-216-821-11	METAL CHIP 1K 5% 1/10W		R54	1-216-833-11	METAL CHIP 10K 5% 1/10W (GT200:AEP,UK/GT200S)	
JC533	1-216-864-11	SHORT CHIP 0		R55	1-216-864-11	SHORT CHIP 0 (GT200:AEP,UK/GT200S)	
JC681	1-216-864-11	SHORT CHIP 0		R56	1-414-595-11	INDUCTOR, FERRITE BEAD (GT200:AEP,UK/GT200S)	
JC753	1-216-296-11	SHORT CHIP 0		R57	1-414-595-11	INDUCTOR, FERRITE BEAD (GT200:AEP,UK/GT200S)	
JC754	1-216-296-11	SHORT CHIP 0		R58	1-216-833-11	METAL CHIP 10K 5% 1/10W (GT200:AEP,UK/GT200S)	
JC755	1-216-296-11	SHORT CHIP 0		R59	1-216-845-11	METAL CHIP 100K 5% 1/10W (GT200:AEP,UK/GT200S)	
JC756	1-216-864-11	SHORT CHIP 0		R60	1-216-833-11	METAL CHIP 10K 5% 1/10W (GT200:AEP,UK/GT200S)	
JC795	1-216-864-11	SHORT CHIP 0		R61	1-216-821-11	METAL CHIP 1K 5% 1/10W (GT200:AEP,UK/GT200S)	
		< COIL >		R301	1-216-821-11	METAL CHIP 1K 5% 1/10W	
L1	1-469-844-11	INDUCTOR 2.2uH		R302	1-216-821-11	METAL CHIP 1K 5% 1/10W	
L51	1-216-295-11	SHORT CHIP 0 (GT200:AEP,UK/GT200S)		R401	1-216-797-11	METAL CHIP 10 5% 1/10W	
L301	1-216-295-11	SHORT CHIP 0		R405	1-218-881-11	METAL CHIP 27K 0.5% 1/10W	
L501	1-216-295-11	SHORT CHIP 0		R406	1-216-809-11	METAL CHIP 100 5% 1/10W	
L601	1-456-617-11	COIL, CHOKE		R407	1-216-809-11	METAL CHIP 100 5% 1/10W	
		< TRANSISTOR >		R408	1-216-809-11	METAL CHIP 100 5% 1/10W	
Q1	6-551-431-01	TRANSISTOR 2SC6027T100		R409	1-216-809-11	METAL CHIP 100 5% 1/10W	
Q22	1-801-806-11	TRANSISTOR DTC144EKA (GT200:AEP,UK/GT200S)		R410	1-216-809-11	METAL CHIP 100 5% 1/10W	
Q51	8-729-600-22	TRANSISTOR 2SA1235-F (GT200:AEP,UK/GT200S)		R411	1-216-809-11	METAL CHIP 100 5% 1/10W	
Q431	8-729-027-44	TRANSISTOR DTC114TKA-T146		R431	1-216-821-11	METAL CHIP 1K 5% 1/10W	
Q441	8-729-027-44	TRANSISTOR DTC114TKA-T146		R432	1-216-841-11	METAL CHIP 47K 5% 1/10W	
Q451	8-729-027-44	TRANSISTOR DTC114TKA-T146		R441	1-216-821-11	METAL CHIP 1K 5% 1/10W	
Q461	8-729-027-44	TRANSISTOR DTC114TKA-T146		R442	1-216-841-11	METAL CHIP 47K 5% 1/10W	
Q471	6-551-392-01	TRANSISTOR RT6N140C-TP-1					
Q478	1-801-806-11	TRANSISTOR DTC144EKA					
Q479	8-729-027-23	TRANSISTOR DTA114EKA-T146					
Q481	6-551-392-01	TRANSISTOR RT6N140C-TP-1					

CDX-GT20W/GT200/GT200E/GT200S/GT250S

MAIN

Ref. No.	Part No.	Description	Remark	Ref. No.	Part No.	Description	Remark
R451	1-216-821-11	METAL CHIP	1K 5% 1/10W	R556	1-216-833-11	METAL CHIP	10K 5% 1/10W
R452	1-216-841-11	METAL CHIP	47K 5% 1/10W				(EXCEPT AEP,UK)
R461	1-216-821-11	METAL CHIP	1K 5% 1/10W	R557	1-216-809-11	METAL CHIP	100 5% 1/10W
R462	1-216-841-11	METAL CHIP	47K 5% 1/10W	R558	1-216-821-11	METAL CHIP	1K 5% 1/10W
R471	1-216-809-11	METAL CHIP	100 5% 1/10W				(GT20W/GT200:US,CND/GT200E/GT250S)
R472	1-216-841-11	METAL CHIP	47K 5% 1/10W	R561	1-216-845-11	METAL CHIP	100K 5% 1/10W
R479	1-216-805-11	METAL CHIP	47 5% 1/10W	R563	1-216-845-11	METAL CHIP	100K 5% 1/10W
R481	1-216-809-11	METAL CHIP	100 5% 1/10W	R564	1-216-845-11	METAL CHIP	100K 5% 1/10W
R482	1-216-841-11	METAL CHIP	47K 5% 1/10W				(AEP,UK)
R502	1-216-821-11	METAL CHIP	1K 5% 1/10W	R565	1-216-845-11	METAL CHIP	100K 5% 1/10W
R503	1-216-821-11	METAL CHIP	1K 5% 1/10W	R566	1-216-845-11	METAL CHIP	100K 5% 1/10W
R504	1-218-871-11	METAL CHIP	10K 0.5% 1/10W	R567	1-216-845-11	METAL CHIP	100K 5% 1/10W
R505	1-218-871-11	METAL CHIP	10K 0.5% 1/10W	R568	1-216-821-11	METAL CHIP	1K 5% 1/10W
R506	1-216-845-11	METAL CHIP	100K 5% 1/10W				(GT20W/GT200:US,CND/GT200E/GT250S)
R507	1-216-845-11	METAL CHIP	100K 5% 1/10W	R570	1-216-817-11	METAL CHIP	470 5% 1/10W
			(GT20W/GT200/GT200S/GT250S)	R573	1-216-845-11	METAL CHIP	100K 5% 1/10W
			(EXCEPT AEP,UK)				(AEP,UK)
R508	1-216-864-11	SHORT CHIP	0	R575	1-216-845-11	METAL CHIP	100K 5% 1/10W
R509	1-216-812-11	METAL CHIP	180 5% 1/10W	R577	1-216-845-11	METAL CHIP	100K 5% 1/10W
R510	1-216-821-11	METAL CHIP	1K 5% 1/10W	R578	1-216-821-11	METAL CHIP	1K 5% 1/10W
R511	1-216-821-11	METAL CHIP	1K 5% 1/10W	R582	1-216-821-11	METAL CHIP	1K 5% 1/10W
R512	1-216-821-11	METAL CHIP	1K 5% 1/10W	R583	1-216-821-11	METAL CHIP	1K 5% 1/10W
R513	1-216-845-11	METAL CHIP	100K 5% 1/10W	R584	1-216-841-11	METAL CHIP	47K 5% 1/10W
R514	1-216-845-11	METAL CHIP	100K 5% 1/10W	R585	1-216-849-11	METAL CHIP	220K 5% 1/10W
R517	1-216-841-11	METAL CHIP	47K 5% 1/10W	R601	1-216-845-11	METAL CHIP	100K 5% 1/10W
R518	1-216-825-11	METAL CHIP	2.2K 5% 1/10W	R609	1-216-821-11	METAL CHIP	1K 5% 1/10W
R519	1-216-845-11	METAL CHIP	100K 5% 1/10W	R631	1-249-425-11	CARBON	4.7K 5% 1/4W
R520	1-216-845-11	METAL CHIP	100K 5% 1/10W	R632	1-216-841-11	METAL CHIP	47K 5% 1/10W
			(GT200E)	R633	1-216-841-11	METAL CHIP	47K 5% 1/10W
R521	1-216-825-11	METAL CHIP	2.2K 5% 1/10W	R634	1-216-829-11	METAL CHIP	4.7K 5% 1/10W
R522	1-216-825-11	METAL CHIP	2.2K 5% 1/10W	R636	1-216-845-11	METAL CHIP	100K 5% 1/10W
R528	1-216-845-11	METAL CHIP	100K 5% 1/10W	R651	1-216-821-11	METAL CHIP	1K 5% 1/10W
R529	1-216-821-11	METAL CHIP	1K 5% 1/10W				(AEP,UK)
R531	1-216-845-11	METAL CHIP	100K 5% 1/10W	R652	1-216-841-11	METAL CHIP	47K 5% 1/10W
R532	1-216-845-11	METAL CHIP	100K 5% 1/10W				(AEP,UK)
R533	1-216-845-11	METAL CHIP	100K 5% 1/10W	R653	1-216-833-11	METAL CHIP	10K 5% 1/10W
R534	1-216-833-11	METAL CHIP	10K 5% 1/10W				(AEP,UK)
R535	1-216-833-11	METAL CHIP	10K 5% 1/10W	R654	1-216-833-11	METAL CHIP	10K 5% 1/10W
							(AEP,UK)
R536	1-216-845-11	METAL CHIP	100K 5% 1/10W	R661	1-216-821-11	METAL CHIP	1K 5% 1/10W
R537	1-216-845-11	METAL CHIP	100K 5% 1/10W	R662	1-216-845-11	METAL CHIP	100K 5% 1/10W
			(AEP,UK,E,MX)	R663	1-216-821-11	METAL CHIP	1K 5% 1/10W
R538	1-216-845-11	METAL CHIP	100K 5% 1/10W	R664	1-216-845-11	METAL CHIP	100K 5% 1/10W
			(US,CND)	R671	1-216-809-11	METAL CHIP	100 5% 1/10W
R539	1-216-821-11	METAL CHIP	1K 5% 1/10W	R672	1-216-809-11	METAL CHIP	100 5% 1/10W
R540	1-216-845-11	METAL CHIP	100K 5% 1/10W	R673	1-216-833-11	METAL CHIP	10K 5% 1/10W
R541	1-216-845-11	METAL CHIP	100K 5% 1/10W	R674	1-216-845-11	METAL CHIP	100K 5% 1/10W
R542	1-216-821-11	METAL CHIP	1K 5% 1/10W	R675	1-216-821-11	METAL CHIP	1K 5% 1/10W
R543	1-216-821-11	METAL CHIP	1K 5% 1/10W	R676	1-216-821-11	METAL CHIP	1K 5% 1/10W
R544	1-216-821-11	METAL CHIP	1K 5% 1/10W	R677	1-216-821-11	METAL CHIP	1K 5% 1/10W
R545	1-216-845-11	METAL CHIP	100K 5% 1/10W	R679	1-216-821-11	METAL CHIP	1K 5% 1/10W
			(GT250S)	R681	1-216-864-11	SHORT CHIP	0
R546	1-216-845-11	METAL CHIP	100K 5% 1/10W	R691	1-216-845-11	METAL CHIP	100K 5% 1/10W
			(GT250S)	R692	1-216-845-11	METAL CHIP	100K 5% 1/10W
R547	1-216-864-11	SHORT CHIP	0	R694	1-216-821-11	METAL CHIP	1K 5% 1/10W
R549	1-216-845-11	METAL CHIP	100K 5% 1/10W				(GT200:AEP,UK/GT200S)
			(GT200E)	R752	1-216-811-11	METAL CHIP	150 5% 1/10W
R550	1-216-845-11	METAL CHIP	100K 5% 1/10W	R756	1-216-841-11	METAL CHIP	47K 5% 1/10W
R551	1-216-845-11	METAL CHIP	100K 5% 1/10W	R757	1-216-864-11	SHORT CHIP	0
			(GT20W/GT200/GT200S)	R901	1-216-817-11	METAL CHIP	470 5% 1/10W

CDX-GT20W/GT200/GT200E/GT200S/GT250S

MAIN **SENSOR** **SERVO**

Ref. No.	Part No.	Description	Remark
R902	1-216-817-11	METAL CHIP	470 5% 1/10W
R903	1-216-834-11	METAL CHIP	12K 5% 1/10W
R904	1-216-834-11	METAL CHIP	12K 5% 1/10W
R905	1-216-841-11	METAL CHIP	47K 5% 1/10W
R906	1-216-841-11	METAL CHIP	47K 5% 1/10W
R907	1-216-845-11	METAL CHIP	100K 5% 1/10W
R910	1-216-789-11	METAL CHIP	2.2 5% 1/10W
R911	1-216-825-11	METAL CHIP	2.2K 5% 1/10W
R912	1-216-864-11	SHORT CHIP	0
R913	1-216-864-11	SHORT CHIP	0
R914	1-216-825-11	METAL CHIP	2.2K 5% 1/10W
		< SWITCH >	
S502	1-571-478-11	SWITCH, SLIDE (FREQUENCY SELECTOR)	(GT250S)
S702	1-786-826-11	SWITCH, TACTILE (RESET)	
		< TUNER UNIT >	
TU1	A-3220-961-A	TUNER UNIT (TUX-032)	
		< VIBRATOR >	
X51	1-813-173-11	VIBRATOR, CRYSTAL (8.664MHz)	(GT200:AEP,UK/GT200S)
X501	1-813-524-21	VIBRATOR, CERAMIC (18.432MHz)	
X502	1-813-202-11	VIBRATOR, CRYSTAL (32.768kHz)	

		SENSOR BOARD	

		< SWITCH >	
SW2	1-529-566-61	SWITCH, PUSH (1 KEY) (SELF)	
SW3	1-529-566-61	SWITCH, PUSH (1 KEY) (DISC IN)	

	A-1132-415-A	SERVO BOARD, COMPLETE	

		< CAPACITOR >	
C7	1-125-777-11	CERAMIC CHIP	0.1uF 10% 10V
C10	1-126-208-21	ELECT CHIP	47uF 20% 4V
C11	1-125-777-11	CERAMIC CHIP	0.1uF 10% 10V
C12	1-125-777-11	CERAMIC CHIP	0.1uF 10% 10V
C13	1-100-567-81	CERAMIC CHIP	0.01uF 10% 25V
C14	1-104-609-11	ELECT CHIP	100uF 20% 4V
C15	1-125-777-11	CERAMIC CHIP	0.1uF 10% 10V
C16	1-162-964-11	CERAMIC CHIP	0.001uF 10% 50V
C17	1-125-777-11	CERAMIC CHIP	0.1uF 10% 10V
C18	1-125-777-11	CERAMIC CHIP	0.1uF 10% 10V
C19	1-125-777-11	CERAMIC CHIP	0.1uF 10% 10V
C20	1-164-677-11	CERAMIC CHIP	0.033uF 10% 16V
C22	1-164-677-11	CERAMIC CHIP	0.033uF 10% 16V
C23	1-125-777-11	CERAMIC CHIP	0.1uF 10% 10V
C24	1-125-777-11	CERAMIC CHIP	0.1uF 10% 10V
C25	1-125-777-11	CERAMIC CHIP	0.1uF 10% 10V
C26	1-162-966-11	CERAMIC CHIP	0.0022uF 10% 50V
C29	1-162-968-11	CERAMIC CHIP	0.0047uF 10% 50V
C30	1-162-968-11	CERAMIC CHIP	0.0047uF 10% 50V
C31	1-125-777-11	CERAMIC CHIP	0.1uF 10% 10V

Ref. No.	Part No.	Description	Remark
C32	1-125-777-11	CERAMIC CHIP	0.1uF 10% 10V
C33	1-125-777-11	CERAMIC CHIP	0.1uF 10% 10V
C36	1-125-777-11	CERAMIC CHIP	0.1uF 10% 10V
C39	1-126-208-21	ELECT CHIP	47uF 20% 4V
C40	1-126-395-11	ELECT CHIP	22uF 20% 16V
C41	1-125-777-11	CERAMIC CHIP	0.1uF 10% 10V
C42	1-125-777-11	CERAMIC CHIP	0.1uF 10% 10V
C43	1-100-567-81	CERAMIC CHIP	0.01uF 10% 25V
C44	1-125-777-11	CERAMIC CHIP	0.1uF 10% 10V
C45	1-125-777-11	CERAMIC CHIP	0.1uF 10% 10V
C46	1-162-923-11	CERAMIC CHIP	47PF 5% 50V
C47	1-164-245-11	CERAMIC CHIP	0.015uF 10% 25V
C48	1-100-567-81	CERAMIC CHIP	0.01uF 10% 25V
C49	1-125-777-11	CERAMIC CHIP	0.1uF 10% 10V
C50	1-100-567-81	CERAMIC CHIP	0.01uF 10% 25V
C51	1-125-777-11	CERAMIC CHIP	0.1uF 10% 10V
C52	1-125-777-11	CERAMIC CHIP	0.1uF 10% 10V
C53	1-125-777-11	CERAMIC CHIP	0.1uF 10% 10V
C54	1-100-567-81	CERAMIC CHIP	0.01uF 10% 25V
C55	1-125-777-11	CERAMIC CHIP	0.1uF 10% 10V
C56	1-164-245-11	CERAMIC CHIP	0.015uF 10% 25V
C58	1-125-777-11	CERAMIC CHIP	0.1uF 10% 10V
C60	1-162-964-11	CERAMIC CHIP	0.001uF 10% 50V
C62	1-125-777-11	CERAMIC CHIP	0.1uF 10% 10V
C66	1-100-567-81	CERAMIC CHIP	0.01uF 10% 25V
C67	1-100-567-81	CERAMIC CHIP	0.01uF 10% 25V
C68	1-100-567-81	CERAMIC CHIP	0.01uF 10% 25V
C69	1-100-567-81	CERAMIC CHIP	0.01uF 10% 25V
C70	1-125-777-11	CERAMIC CHIP	0.1uF 10% 10V
C71	1-125-777-11	CERAMIC CHIP	0.1uF 10% 10V
C72	1-125-777-11	CERAMIC CHIP	0.1uF 10% 10V
C80	1-125-837-11	CERAMIC CHIP	1uF 10% 6.3V
C132	1-125-837-11	CERAMIC CHIP	1uF 10% 6.3V
C133	1-125-837-11	CERAMIC CHIP	1uF 10% 6.3V
		< CONNECTOR >	
CN1	1-691-380-21	CONNECTOR, FFC/FPC 16P	
CN2	1-817-275-21	CONNECTOR, BOARD TO BOARD 28P	
		< JUMPER RESISTOR >	
FB2	1-216-864-11	SHORT CHIP	0
FB3	1-216-864-11	SHORT CHIP	0
FB4	1-216-864-11	SHORT CHIP	0
		< IC >	
IC1	6-707-327-01	IC BA5968FP-E2	
IC2	6-708-729-01	IC TC94A70FG-002	
IC3	6-806-019-01	IC MB90486BPFV-G-158E1	
IC6	6-708-728-01	IC BH15LB1WG	
		< TRANSISTOR >	
Q2	6-551-120-01	TRANSISTOR 2SA2119K	
Q3	8-729-928-90	TRANSISTOR DTC114EE	
Q21	8-729-904-87	TRANSISTOR 2SB1197K-R	
		< RESISTOR >	
R1	1-218-965-11	RES-CHIP	10K 5% 1/16W
R2	1-218-977-11	RES-CHIP	100K 5% 1/16W

Ref. No.	Part No.	Description			Remark	Ref. No.	Part No.	Description			Remark
R5	1-218-969-11	RES-CHIP	22K	5%	1/16W	R73	1-218-973-11	RES-CHIP	47K	5%	1/16W
R6	1-218-969-11	RES-CHIP	22K	5%	1/16W	R74	1-218-941-81	RES-CHIP	100	5%	1/16W
R7	1-218-990-81	SHORT CHIP	0			R75	1-218-941-81	RES-CHIP	100	5%	1/16W
R8	1-218-965-11	RES-CHIP	10K	5%	1/16W	R77	1-218-973-11	RES-CHIP	47K	5%	1/16W
R9	1-218-965-11	RES-CHIP	10K	5%	1/16W	R78	1-218-941-81	RES-CHIP	100	5%	1/16W
R10	1-218-990-81	SHORT CHIP	0			R79	1-218-941-81	RES-CHIP	100	5%	1/16W
R11	1-218-941-81	RES-CHIP	100	5%	1/16W	R80	1-218-941-81	RES-CHIP	100	5%	1/16W
R12	1-218-969-11	RES-CHIP	22K	5%	1/16W	R81	1-218-941-81	RES-CHIP	100	5%	1/16W
R13	1-218-969-11	RES-CHIP	22K	5%	1/16W	R82	1-218-941-81	RES-CHIP	100	5%	1/16W
R14	1-218-929-11	RES-CHIP	10	5%	1/16W	R83	1-218-977-11	RES-CHIP	100K	5%	1/16W
R15	1-218-929-11	RES-CHIP	10	5%	1/16W	R84	1-218-941-81	RES-CHIP	100	5%	1/16W
R16	1-218-953-11	RES-CHIP	1K	5%	1/16W	R85	1-218-977-11	RES-CHIP	100K	5%	1/16W
R17	1-218-990-81	SHORT CHIP	0			R86	1-218-941-81	RES-CHIP	100	5%	1/16W
R18	1-218-941-81	RES-CHIP	100	5%	1/16W	R87	1-218-977-11	RES-CHIP	100K	5%	1/16W
R19	1-218-935-11	RES-CHIP	33	5%	1/16W	R96	1-218-941-81	RES-CHIP	100	5%	1/16W
R20	1-162-961-11	CERAMIC CHIP	330PF	10%	50V	R97	1-220-200-81	RES-CHIP	30K	5%	1/16W
R21	1-218-941-81	RES-CHIP	100	5%	1/16W	R98	1-218-971-11	RES-CHIP	33K	5%	1/16W
R22	1-218-977-11	RES-CHIP	100K	5%	1/16W	R132	1-218-969-11	RES-CHIP	22K	5%	1/16W
R23	1-218-977-11	RES-CHIP	100K	5%	1/16W	R133	1-218-953-11	RES-CHIP	1K	5%	1/16W
R24	1-218-977-11	RES-CHIP	100K	5%	1/16W	R141	1-216-864-11	SHORT CHIP	0		
R25	1-218-977-11	RES-CHIP	100K	5%	1/16W	R144	1-216-864-11	SHORT CHIP	0		
R26	1-218-977-11	RES-CHIP	100K	5%	1/16W	R147	1-216-864-11	SHORT CHIP	0		
R27	1-218-977-11	RES-CHIP	100K	5%	1/16W			< SWITCH >			
R28	1-218-945-11	RES-CHIP	220	5%	1/16W	SW1	1-529-565-61	SWITCH, PUSH (1 KEY) (DOWN)			
R29	1-218-989-11	RES-CHIP	1M	5%	1/16W			< VIBRATOR >			
R30	1-218-989-11	RES-CHIP	1M	5%	1/16W	X1	1-813-678-11	OSCILLATOR, CERAMIC (CHIP TYPE) (12MHz)			
R31	1-218-989-11	RES-CHIP	1M	5%	1/16W	X2	1-795-561-21	VIBRATOR, CERAMIC (16.9344MHz)			
R32	1-218-947-11	RES-CHIP	330	5%	1/16W			*****			
R33	1-218-990-81	SHORT CHIP	0					MISCELLANEOUS			
R34	1-216-864-11	SHORT CHIP	0					*****			
R35	1-162-961-11	CERAMIC CHIP	330PF	10%	50V	8	1-776-206-21	CORD (WITH CONNECTOR) (POWER)			
R36	1-218-947-11	RES-CHIP	330	5%	1/16W			(EXCEPT AEP,UK)			
R37	1-218-947-11	RES-CHIP	330	5%	1/16W	8	1-776-527-61	CORD (WITH CONNECTOR) (ISO) (POWER)			
R38	1-218-941-81	RES-CHIP	100	5%	1/16W			(AEP,UK)			
R39	1-218-941-81	RES-CHIP	100	5%	1/16W	57	1-780-199-11	CONDUCTIVE BOARD, CONNECTION			
R40	1-218-941-81	RES-CHIP	100	5%	1/16W	△ 153	8-820-207-12	OPTICAL PICK-UP (KSS1000E/K1RP)			
R41	1-218-941-81	RES-CHIP	100	5%	1/16W	154	A-1088-615-A	CHASSIS (OP) SUB ASSY (including M901)			
R42	1-218-977-11	RES-CHIP	100K	5%	1/16W	LCD901	1-805-919-11	DISPLAY PANEL, LIQUID CRYSTAL			
R43	1-218-961-11	RES-CHIP	4.7K	5%	1/16W			(AEP,UK,E,MX)			
R44	1-218-977-11	RES-CHIP	100K	5%	1/16W	LCD901	1-805-920-11	DISPLAY PANEL, LIQUID CRYSTAL (US,CND)			
R52	1-218-962-11	RES-CHIP	5.6K	5%	1/16W	M902	A-1088-614-A	MOTOR ASSY, SL (SLED)			
R53	1-218-979-11	RES-CHIP	150K	5%	1/16W	M903	A-1088-622-A	MOTOR ASSY, LE (LOADING)			
R54	1-218-990-81	SHORT CHIP	0			RE901	1-478-474-12	ENCODER, ROTARY (PUSH SELECT/VOLUME)			
R55	1-218-973-11	RES-CHIP	47K	5%	1/16W	SW4	1-786-339-11	SWITCH (M) (LIMIT)			
R57	1-218-967-11	RES-CHIP	15K	5%	1/16W			*****			
R58	1-218-969-11	RES-CHIP	22K	5%	1/16W						
R60	1-218-941-81	RES-CHIP	100	5%	1/16W						
R61	1-218-941-81	RES-CHIP	100	5%	1/16W						
R62	1-218-941-81	RES-CHIP	100	5%	1/16W						
R63	1-218-977-11	RES-CHIP	100K	5%	1/16W						
R64	1-218-977-11	RES-CHIP	100K	5%	1/16W						
R65	1-218-977-11	RES-CHIP	100K	5%	1/16W						
R67	1-218-941-81	RES-CHIP	100	5%	1/16W						
R68	1-218-941-81	RES-CHIP	100	5%	1/16W						
R69	1-218-941-81	RES-CHIP	100	5%	1/16W						
R70	1-218-965-11	RES-CHIP	10K	5%	1/16W						
R71	1-218-973-11	RES-CHIP	47K	5%	1/16W						
R72	1-218-973-11	RES-CHIP	47K	5%	1/16W						

CDX-GT20W/GT200/GT200E/GT200S/GT250S

Ref. No.	Part No.	Description	Remark
		ACCESSORIES	

1-479-077-12		REMOTE COMMANDER (RM-X151) (GT20W:US/GT200:US,CND/GT250S)	
2-548-729-01		LID, BATTERY CASE (for RM-X151) (GT20W:US/GT200:US,CND/GT250S)	
2-651-185-11		MANUAL, INSTRUCTION (ENGLISH,FRENCH) (GT20W:CND/GT200:US,CND)	
2-651-185-21		MANUAL, INSTRUCTION (ENGLISH,GERMAN, FRENCH,ITALIAN,DUTCH) (GT200:AEP,UK/GT200S)	
2-651-185-31		MANUAL, INSTRUCTION (ENGLISH,RUSSIAN) (GT200E)	
2-651-185-41		MANUAL, INSTRUCTION (ENGLISH,SPANISH, SIMPLIFIED CHINESE) (GT250S)	
2-651-185-51		MANUAL, INSTRUCTION (ENGLISH,SPANISH) (GT20W:US)	
2-651-186-11		MANUAL, INSTRUCTION, INSTALL (ENGLISH, FRENCH) (GT20W:CND/GT200:US,CND)	
2-651-186-21		MANUAL, INSTRUCTION, INSTALL (ENGLISH, GERMAN,FRENCH,ITALIAN,DUTCH) (GT200:AEP,UK/GT200S)	
2-651-186-31		MANUAL, INSTRUCTION, INSTALL (ENGLISH, RUSSIAN) (GT200E)	
2-651-186-41		MANUAL, INSTRUCTION, INSTALL (ENGLISH, SPANISH,SIMPLIFIED CHINESE) (GT250S)	
2-651-186-51		MANUAL, INSTRUCTION, INSTALL (ENGLISH, SPANISH) (GT20W:US)	
X-2024-133-3		CASE ASSY (for FRONT PANEL) (EXCEPT US)	

Ref. No.	Part No.	Description	Remark
		PARTS FOR INSTALLATION AND CONNECTIONS	

301	X-3382-647-1	FRAME ASSY, FITTING	
302	2-187-743-02	COLLAR	
303	3-246-011-01	KEY (FRAME)	
304	A-1082-993-A	SCREW ASSY (BS4), FITTING (GT200E/GT250S)	
304	X-3366-972-2	SCREW ASSY (EXP), FITTING (GT200:AEP,UK/GT200S)	
305	3-259-776-01	SCREW (+K 5X8 TP) (GT20W/GT200:US,CND/GT200E/GT250S)	
306	1-465-459-41	ADAPTOR, ANTENNA (AEP,UK)	
307	1-776-206-21	CORD (WITH CONNECTOR) (POWER) (EXCEPT AEP,UK)	
308	1-776-527-61	CORD (WITH CONNECTOR) (ISO) (POWER) (AEP,UK)	

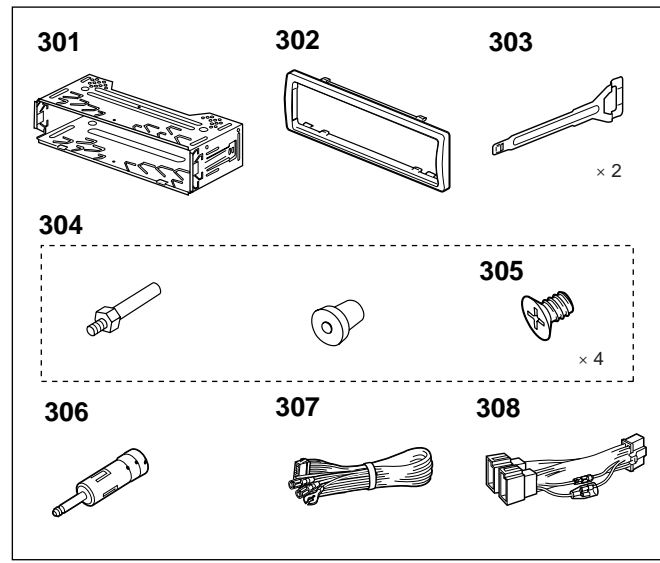

MEMO

