

SOMERSET



CDR-700

Side Operated Dough Sheeter OPERATIONS MANUAL

SOMERSET INDUSTRIES

137 PHOENIX AVE • LOWELL, MA 01852 • USA • +1-978-667-3355

Email: somerset@smrset.com

Web: www.smrset.com

NOTICE: !! READ CAREFULLY ALL INSTRUCTIONS BEFORE YOU START!!

UNCRATING AND SETUP

Cut off the fastener wrapped around the machine and the base.

Lift the machine straight up out of the wooden base.

Install the machine in its final position or temporarily secure it to a solid surface.

Slide the infeed tray into the machine, as shown on Fig. 1.

Remove scraper #1 (unhook the springs and lift the scraper up).

Mount discharge tray as shown in Fig. 1.

Reinstall scraper #1.

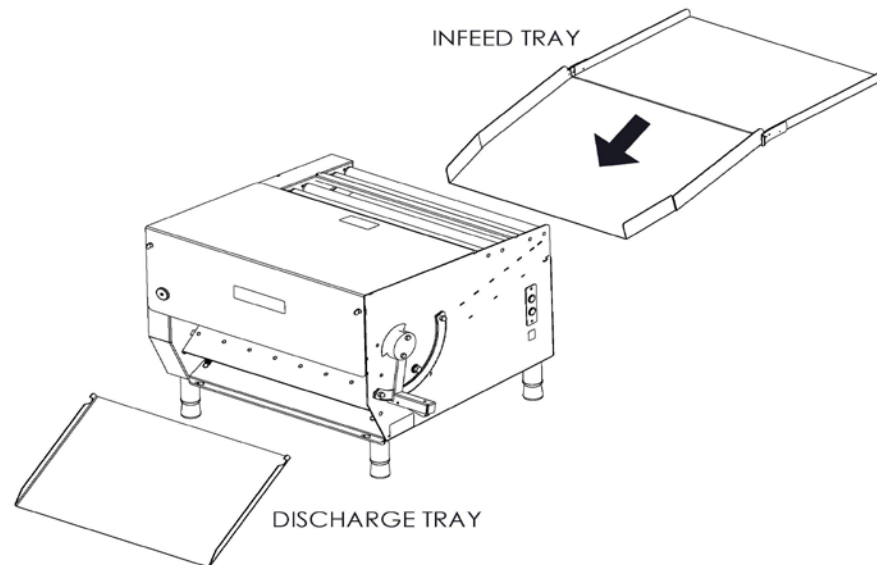

Fig.1

Wipe off any dirt that may accumulate during shipping. Use a soft cloth.

Check the nameplate for correct voltage and frequency.

Plug the machine to the proper power source that matches the nameplate requirements.

Turn the power switch "ON"(green button) and check for proper operation of the machine.

WARNING!!

- * **NEVER OPERATE THE MACHINE WITHOUT GUARDS IN PLACE**
- * **KEEP YOUR HANDS FROM IN FEED AREAS**
- * **DO NOT INSERT FOREIGN OBJECTS INTO THE IN FEED TRAY**
- * **DO NOT CLEAN MACHINE WHILE CONNECTED TO ELECTRICAL SUPPLY**
- * **WATCH YOUR HANDS AND FINGERS**

NOTE: The machine will not operate when safety cover is removed.

OPERATING PROCEDURES

The rollers are easily adjustable to any thickness of crust you may need.
Release the adjusting handle, by squeezing the handle.
Move the handle to the left, to decrease the dough thickness.
Move the handle to the right, increase the dough thickness.

OPERATION

Dust the infeed tray with flour before using the machine.
For best results the dough to be rolled should be at room temperature.
Dust the dough with flour when putting it on the in feed tray.

If the dough tears or the machine makes a thumping sound, this indicates that the dough is too thick to go through that particular setting of the rollers or the dough is too cold and stiff and requires longer rest period before use.

- * **IF THE DOUGH GETS STUCK, TURN THE POWER OFF, REMOVE SAFETY COVER THEN REMOVE THE DOUGH.**
- * **NEVER ATTEMPT TO MOVE THE DOUGH BY HAND WHILE THE MACHINE IS RUNNING.**

CLEANING

BEFORE CLEANING: TURN POWER OFF AND DISCONNECT POWER CORD.

Remove the safety cover by removing the two thumbscrews.
All scrapers are readily removable.
Remove top scraper (#3) from its mounting pins by pushing scraper downward.
Unhook both springs by lifting scraper up and remove it.
Unhook both springs attached on bottom scraper (#2) and remove it by lifting up.
By removing both scrapers, the whole machine is exposed and ready to be cleaned.
Clean the rolls with dry cloth (never use water).
Wipe rollers with lightly oiled cloth (use vegetable oil).
Wash, dry and apply a thin film of vegetable oil on the edge of each scraper that touches the roller.
Install the scrapers in the opposite order of their removal.
Close the safety cover and secure it with the 2 thumbscrews.
Reconnect the power cord to the same power outlet that was disconnected from.
The machine is ready for use.

!! CAUTION !!

!! THIS MACHINE IS MAINTENANCE FREE. !!
!! NEVER USE OIL OR GREASE ON ANY OF THE PARTS
OF THE MACHINE. !!
!! ALL PARTS ARE PERMANENT SELF-LUBRICATED. !!

ITEM NO.	PART NUMBER	DESCRIPTION	QTY.
1	0700-010	FRAME CDR-700 MAIN	1
	0700-011	BASE, RIGHT SIDE	1
	0700-015	RAIL,SLIDE	1
	0700-130	STUD,TRAY SUPPORT	1
	2000-015	LOCATOR PLATE	1
	3010-219	PEM, HFH-0616-16ZI	4
	3010-206	PEM, FHS 420-12	2
	3010-203	PEM, FHS-207-8	2
	3010-201	PEM, YC3-16144	1
	3010-204	PEM, FHS-0518-8	4
	0700-011	BASE,RIGHT SIDE	1
	0700-012	SIDE LEFT	1
	0700-015	RAIL,SLIDE	1
	0700-130	STUD,TRAY SUPPORT	1
	0500-015	LOCATOR HSG #10	6
	3010-201	PEM, YC3-16144	1
	3010-203	PEM, FHS-207-8	2
	3010-204	PEM, FHS-0518-8	5
	3010-205	PEM, FHS-832-6	14
	3010-212	PEM, FHS-440-6	2
	0700-012	SIDE, LEFT	1
	0700-013	PARTITION	1
	3010-201	PEM, YC3-16144	2
	2000-017	CHANNEL, TOP	4
	0500-017	CHANNEL, TOP	1
	0300-017	CHANNEL, TOP	1
	3010-207	PEM, YC3-16271	2
	2000-415	LEG, ASM COMPLETE	4
	4000-200	INSERT, LEG ADJ	1
	2000-413	LEG, WELDMENT TUBE&PLUG	1
	4000-233	SPACER, HEX 0.5 X 1.0	4
	3010-153	STUD, SCRAPER 2"	1
	3000-303	NUT, FLANGE 1/4-20	2
	3000-406	SCREW, 5/16-18 X 3/4 HEXHD GR8	1
	3000-102	WASHER, LOCK SPLIT 5/16	1
	2000-431	SHAFT,ALIGNMENT, IDLER SUPPORT	1
2	0700-402	ROLL ASM MIDDLE UHMW 700	1
	2000-408	SHAFT, MIDDLE 20	1
	2000-457	ROLL SYNTHETIC/PIPE 20"	1
	2000-403	PIPE ROLL 21.110	1
	2000-451	ROLL ETF 00039TIVAR 20.125	1
	4000-100	BEARING, R12RS ROLL	2
	4000-508	SPROCKET, 40B18H ROLL	1
	3010-302	PIN, 21S 187-125	1
	2000-316	DISC MIDDLE COMPLETE	1
	2000-319	DISC, MIDDLE	1
	2000-023	BRACKET, DISK	2
3	2000-400	ROLL ASM UPPER	1
	2000-407	SHAFT, UPPER AND LOWER	1
	2000-457	ROLL SYNTHETIC/PIPE 20"	1
	2000-403	PIPE ROLL 21.110	1
	2000-451	ROLL ETF 00039TIVAR 20.125	1
	4000-100	BEARING, R12RS ROLL	2
	2000-412	SPROCKET 41B18H ROLL	1
	2000-318	DISC, TOP COMPLETE	1
	2000-320	DISC, TOP	1
	2000-023	BRACKET, DISC	2
	3000-225	WASHER, NYLATRON 1.50	2
	3010-302	PIN, 21S 187-125	3
	2000-411	ECCENTRIC, UNIVERSAL	2
4	0700-501	SCRAPER #2 COMPLETE	1
	2000-523	SHAFT SCRAPER #4 2000	1
	0700-511	SCRAPER #2	1
	3010-202	PEM, FHS-0420-16	8
	3000-303	NUT, FLANGE 1/4-20	8
	3010-152	STUD, SCRAPER 2 1/2"	2
	3000-306	NUT, HEX 1/4-20	2

ITEM NO.	PART NUMBER	DESCRIPTION	QTY.
	4000-251	SPRING, SCRAPER	2
5	0700-502	SCRAPER #3 COMPLETE 700	1
	2100-520	SHAFT, SCRAPER #1 2100	1
	0700-512	SCRAPER #3 700	1
	3010-202	PEM, FHS-0420-16	8
	3000-303	NUT, FLANGE 1/4-20	8
	3010-100	STUD,SCRAPER 21/32 BENT	2
	3000-306	NUT, HEX 1/4-20	2
	4000-251	SPRING, SCRAPER	2
6	0700-424	HANDLE, ADJUST COMPLETE	1
	0700-420	HANDLE, ADJUST COMPLETE	1
	3010-303	PIN, 21S 187-100	1
	4000-256	SPRING, HANDLE COMPRESSION	1
	0700-423	TRIGGER, HANDLE	1
	3010-216	PEM, FHS-032-6	1
7	0700-120	COVER,SAFETY	1
	0700-121	COVER, SAFETY	1
	4000-150	MAGNET,SAFETY COVER	1
	3010-500	RIVET, 1/8 X .375	1
8	0700-300	TRAY,INTAKE	1
	0700-299	BRACKET, WEDGE FILLER	2
	0700-298	BRACKET,TRAY STOP	1
	0700-297	BRACKET,TRAY STOP	1
9	0700-236	PLATE, ECCENTRIC COMPLETE	1
	0700-231	PLATE,ECCENTRIC	1
	3010-206	PEM, FHS 420-12	3
	0700-235	PLATE, RING REINFORCE	1
10	0700-233	PLATE,ECCENTRIC	2
11	0700-234	PLATE,ECCENTRIC	1
12	0700-232	PLATE,ECCENTRIC	1
13	0700-018	BRACKET,SAFETY ROLLER	4
	3010-204	PEM, FHS-0518-8	1
14	0700-118	BRACKET, ECCENTRIC	1
15	0700-301	PANEL,LOUVERED	1
16	0700-302	COVER,HOUSING	1
17	5000-133	MOTOR/BASE ASSY SUMITOMO 1HP	1
	5000-110	MOTOR, 1HP SUMITOMO	1
	0700-024	BASE, MOTOR SUMITOMO 1HP	1
	3010-215	PEM, FH 518-8 ZI	9
	5000-234	HARNESS, CORD POWER 19" MALE	1
	2000-534	PAD, RUBBER MOTOR	2
	5000-269	CONNECTOR, ROMEX	1
	3000-414	SCREW, 5/16-18 X 1 HEXHD	4
	3000-305	NUT, FLANGE 5/16-18	4
18	2000-632	RELAY 110 VAC	1
	2000-328	BRACKET, RELAY	1
	3010-205	PEM, FHS-832-6	3
	3010-206	PEM, FHS 420-12	1
	2000-328	BRACKET, RELAY	1
	5000-230	HARNESS, POWER MOLDED	1
	5000-150	RELAY, 120 VAC	1
	3000-416	SCREW, 8-32 X 1 PAN HD PH	1
	3000-300	NUT, FLANGE 8-32	3
19	0700-304	TRAY, DISCHARGE 700	1
20	0700-328	SPACER,TUBE ADJ PLATE	2
21	0700-417	PLATE,ADJUST	2
22	0700-623	COVER, ECCENTRIC COMPLETE	1
23	0700-624	ROLLER, ASSY COMPLETE 0700	4
	0700-100	BAR,SAFETY	1
	4000-315	BUSHING, NYLON	2
24	2000-629	SWITCH PLATE ASSY	1
	2000-330	PLATE, P.B. SWITCH	1
	3010-205	PEM, FHS-832-6	2
	2000-330	PLATE, P.B. SWITCH	1

ITEM NO.	PART NUMBER	DESCRIPTION	QTY.
	5000-202	SWITCH POWER RED	1
	5000-203	SWITCH POWER GREEN	1
25	4000-010	SPACER,TUBE ADJ PLATE	2
26	4000-523	SPROCKET,40B11 W/ BUSHING	1
	4000-512	SPROCKET,40B11H IDLER	1
	4000-556	BUSHING, 12DU14 GARLOCK	1
27	4000-432	SHAFT TAKE UP SPROCKET	1
28	4000-510	SPROCKET, 40B16H	1
29	4000-358	CHAIN,40 RIV 91 (700)	1
30	5000-276	BUSHING, 90 STR REL HEYCO1320	1
31	5000-278	BUSHING, FINGER .625 HOLE	1
32	5000-312	LABEL, "SOMERSET" 3"	1
33	5000-313	LABEL, "KEEP FINGERS..."	1
34	5000-311	LABEL, ETL	1
35	5000-314	LABEL, "DO NOT OPERATE..."	1
36	5000-316	LABEL, CCW INDICATOR GRADUATED	1
37	5000-317	LABEL, NSF	1
38	5000-321	LABEL, "ARROW" RED	1
39	3000-225	WASHER, NYLATRON 1.50	3
40	3000-300	NUT, FLANGE 8-32	16
41	3000-102	WASHER, LOCK SPLIT 5/16	6
42	3000-405	SCREW, 5/16-18 X 1/2 HEXHD	6
43	3000-201	WASHER, FLAT 3/8	2
44	3000-103	WASHER, LOCK SPLIT 3/8	2
45	3000-409	SCREW, 3/8-16X1 HEXHD SS	2
46	3000-303	NUT, FLANGE 1/4-20	4
47	3000-410	SCREW, 1/4-20 X 1/2 HEXHD	4
48	3000-403	SCREW, 1/4-20 X 1/2 THUMB W/SHOULDER	2
49	3000-101	WASHER LOCK #10 INT TOOTH	17
50	3000-402	SCREW, 10-32 X 3/8 TRUSS PH SS	17
51	3000-302	NUT, ACORN 1/4-20	2
52	3000-404	SCREW, 1/4-20 X 3/4 HEXHD	2
53	3000-305	NUT, FLANGE 5/16-18	9
54	3000-204	WASHER, FLAT #4	2
55	3000-309	NUT, HEX 4-40	2
56	4000-300	LEG TIP RUBBER	4
57	4000-011	SPACER .50ID X .78OD X .123 PL	1
58	4000-506	SPROCKET ASSY, TENSION W/ BRG	1
59	4000-652	BUSHING,OILLITE (FROM 400-552)	1
60	2000-428	ARM, IDLER	1
61	5000-225	SWITCH, ELECTRONIC	1
62	5000-261	ORANGE WIRE NUT	5
63	5000-272	CABLE TIE, 3M	5
64	2000-431	SHAFT,ALIGNMENT, IDLER SUPPORT	8

UNLESS OTHERWISE SPECIFIED: **SOMERSET** SOMERSET INDUSTRIES, INC.

DIMENSIONS ARE IN INCHES (MILLIMETER)
 XX ± .015 [-.4]
 XXX ± .005 [-.13] FRACTIONAL ± 1/32 [-.8]
 XXXX ± .0009 [-.013] ANGULAR ± 1°

THE INFORMATION CONTAINED IN THIS DRAWING AND ASSOCIATED CAD DATA FILES IS THE SOLE PROPERTY OF SOMERSET INDUSTRIES. IT MAY NOT BE REPRODUCED IN PART, OR AS A WHOLE, OR SENT TO ANY OTHER VENDOR, WITHOUT THE EXPRESS WRITTEN CONSENT OF SOMERSET INDUSTRIES.

INTERPRET DRAWING PER: ANDY/MSM-1982
 MATERIAL: SEE NOTES
 FINISH: N/A
 DATABASE: SOLIDWORKS

DRAWN: G. HURLEY
 CHECKED: ENG APPR.
 ENG APPR.:
 MFG APPR.:
 G.A.

NAME: G. HURLEY
 DATE: 12/14/2012

TITLE: 0700 EXPLODED

SIZE: DWG. NO. **D 0700-PART** REV **C**
 SCALE: 1:2.5 WEIGHT N/A SHEET 2 OF 2