



SERVICE and PARTS MANUAL

SD3 Series

SD3

ML-130232



TABLE OF CONTENTS

GENERAL	3
INTRODUCTION	3
MODELS COVERED	3
SPECIFICATIONS	3
REFERENCE MATERIAL	4
POWER-UP	4
FILL CYCLE	4
BOOSTER TEMPERATURE CONTROL	4
BOOSTER TEMPERATURE CONTROL	4
READY MODE	5
RUNNING A CYCLE	5
CHANGING CYCLE TIME	5
CHANGING CYCLE TIME	5
LUBRICATION	5
TOOLS	5
SERVICE PROCEDURES AND ADJUSTMENTS	6
CONTROL BOARD PROGRAMMING	6
SERVICE PROGRAMMING	7
TANK HEATER - TEST	10
BOOSTER HEATER - TEST	11
PUMP MOTOR - TEST	12
THERMISTOR - TEST 1QTM, 2QTM & 3QTM	12
QUICK CHECK USING SERVICE DIAGNOSTICS	12
MEASURING THERMISTOR RESISTANCE	12
TRANSFORMER 1T - TEST	13
TRANSFORMER 2T - TEST	14
DELIMITING PROCEDURE	15
DOOR TENSION ADJUSTMENT	15
ELECTRICAL OPERATION	16
COMPONENT FUNCTION	16
COMPONENT LOCATION	17
CONTROL BOARD / RELAY BOARD LAYOUT	18
SEQUENCE OF OPERATION	19
CONTROL AND RELAY BOARD LEDS	21
WIRING DIAGRAM - 1 PHASE	23
WIRING DIAGRAM - 3 PHASE	24
TROUBLESHOOTING	25
QUICK REFERENCE CHART - ELECTRIC HEAT	25
CONTROL BOARD AND RELAY BOARD LEDS	27
CONTROL BOARD AND RELAY BOARD	27
OPERATING CONDITIONS	27
NO DISPLAY AFTER ON KEY IS PRESSED	28
NO FILL OR RINSE	29
LONG FILL TIME (6 MINUTES)	30
NO WASH CYCLE	30
NO TANK HEAT	31
SERVICE DIAGNOSTICS	32
SERVICE DIAGNOSTICS CHART	33
OUTPUT TESTS	34
VERIFY CONTROL BOARD IS CONFIGURED AS AN SD3	35
ERROR CODE CHART	35
TROUBLESHOOTING TABLE	35
PARTS CATALOG	36

GENERAL

INTRODUCTION

This manual is applicable to the models and ML numbers listed on the cover page. Procedures apply to all models unless specified otherwise.

MODELS COVERED

SD3-H: Single water inlet. Incoming water of 110°F minimum is heated by a booster tank mounted on the machine. The machine is configured for a 70°F rise depending on incoming water temperature. The booster maintains water temperature to be used for 180°F final rinse.

SD3-P: Single water inlet. Water temperature to machine must be a minimum of 180°F for the final rinse. This water is provided by the customer external of the machine. The SD3-P has the option to be reprogrammed to change from plain to chemical.

- Low water protection.
- One incoming plumbing connection to dishwasher through an electrically operated valve.
- The fill/rinse valve is installed prior to the 3.6 gallon booster tank.
- Supply flowing water pressure 20 ±5 psi.
- Provides a minimum 70°F rise with incoming water temperature of 110°F for a final rinse temperature of 180°F at 20 psi (flowing).
- The dishwasher, with the booster, can operate at full capacity with back-to-back cycles (SD3).
- SD3 machines are available in several operating voltages for single or three phase operation.

SPECIFICATIONS

- Operates as an atmospheric booster (SD3 with built-in booster).

ELECTRICAL SPECIFICATIONS

Model	Electrical Specs	Rated Amps	Minimum Supply Circuit Conductor Ampacity	Maximum Overcurrent Protective Device
SD3 with Electric Heat	208-240/60/1	43.0	50	50
	208-240/60/3	24.9	30	30
	480/60/3	13.4	15	15
Booster Ampacity Ratings 8.5KW	208-240/60/1	35.4	50	50
	208-240/60/3	20.4	30	30
	480/60/3	10.2	15	15
Optional SD3 Single Point Electrical Service Connection	208-240/60/3	45.4	60	60
	480/60/3	23.7	30	30

WATER SUPPLY REQUIREMENTS

Model	Temperature (minimum)	Flowing Pressure	Hardness grains/gal. ¹	Chlorides ppm	Water Usage
SD3 -P (Plain)	140°F	20±5 psi	Under 3	≤ 50	0.74 gal/rack
SD3-H (Hot)	110°F		1 to 3		

WATER SUPPLY REQUIREMENTS					
Model	Temperature (minimum)	Flowing Pressure	Hardness grains/gal. ¹	Chlorides ppm	Water Usage
¹ Water hardness below 4 grains/gal requires water treatment to reduce potential corrosion. Hardness above 6 grains/gal should be treated by water conditioner, water softener or in-line treatment.					

MACHINE CYCLE TIMES AND CAPACITY (RACKS / HOUR)							
Model	Cycle Settings	Time in Seconds (maximum time settings)					
		1st 1/2 Fill	2nd 1/2 Fill	Wash Duration ¹	Dwell ²	Rinse ²	Sani-Dwell ²
All	1	Variable up to 150	Variable 75-120	38 (38-99)	2 (2-15)	10 (10-35)	7 (7-15)
	2			120			
	4			360			

¹ Machine cycles 1, 2, and 4 are selected via the keypad. Cycle 1 wash duration is adjustable through the SERVICE PROGRAMMING mode, where the wash time can be adjusted to values above NSF minimums.

² Dwell, rinse and sani-dwell times are adjustable to values above NSF minimums. Times chosen for each parameter will apply to all cycle selections.

REFERENCE MATERIAL

For replacement parts, refer to SD3 Catalog of Replacement Parts.

Refer to Lubrications Manual F-20067 for current values.

For operation and care instructions, refer to Operator's Manual.

POWER-UP

On power-up, the control board will perform a self-test. Once the control successfully completes and exits the selftest routine, the machine is ready for operation.

FILL CYCLE

The fill consists of two parts. The first part of the fill is defined as the time required to fill the tank until the float switch 1FS closes (150 seconds maximum). The time duration for the second part of the fill is equal to the time elapsed for the first part of fill multiplied by 1.25 (75 seconds minimum, 120 seconds maximum).

The chamber door must be closed for the fill/rinse solenoid (1SOL) to be energized and begin filling the tank. Opening the chamber door before the float switch is closed will de-energize the fill/rinse solenoid 1SOL suspending the fill cycle. When the chamber door is closed, the fill cycle will continue. If the

chamber door is opened any time after the float switch is closed, the fill cycle will be terminated, even if second part of fill did not complete. When the chamber door is closed after the float switch is closed, a wash cycle will begin.

If the float switch does not close after the maximum allowed time for the first half of fill (150 seconds), an [E2] error code will be displayed. To clear an error from the display, cycle power by turning the machine off then back on. When the float switch closes, the controls will begin regulating tank heat. When the fill cycle is complete, the FILL icon turns off while the tank temperature continues to be displayed. The machine will continue heating the tank as required to reach and maintain the tank heat set point.

BOOSTER TEMPERATURE CONTROL

Booster Temperature Control

NOTE: The Rinse Assurance is on by default for an SD3. Adjustments to this selection can be made by the service technician through CONTROL BOARD PROGRAMMING.

Once the initial fill is complete, if no cycles are run, the booster has eight minutes to reach its set point. If the booster does not reach temperature within the eight minute timeout, an error code [EE] will be displayed. To clear an error from the display, cycle power by turning the machine off then back on.

The control board is programmed to cause the booster heater to turn on at the beginning of every rinse cycle and turn off at the end of the cycle. This occurs even if the booster water temperature meets or is above the booster temperature set point. Should the booster temperature be below the set-point, the booster heater will remain energized until set-point is achieved.

If the booster water temperature is below the booster temperature set point at the end of a wash cycle, and Rinse Assurance is enabled, the wash cycle will be extended (maximum total wash time is one minute). The extended wash time allows the booster water temperature to reach set point before the rinse cycle begins.

The tank float also controls the heat for the booster. If the float is down (float switch open), the booster heater circuit will be disabled. If the float is up (float switch closed), the control board will regulate the booster heat as needed.

READY MODE

When a cycle is not in progress, the machine will be maintained in a ready state. In the ready state, tank and booster temperatures are maintained. If water level drops below the tank float in ready mode, tank and booster heating elements are de-energized and a fill cycle will be initiated the next time the chamber door is opened and then closed. An error code [Ed] will be displayed indicating the machine has a slow leak. To clear an error from the display, cycle power by turning the machine off then back on.

RUNNING A CYCLE

After the fill cycle is complete, a cycle is initiated by raising and lowering the chamber door.

NOTE: If the chamber door is raised any time during a cycle, the wash pump and rinse solenoid will deenergize. The control will start a new cycle once the chamber door is closed.

CHANGING CYCLE TIME

Changing Cycle Time

Wash cycle duration can be selected at any time whether the machine is at rest or in a cycle. Pressing the CYCLE button will step through the pre-programmed timed cycle selections 1, 2, or 4. The selected cycle time will be retained by the control even when power is removed and turned back on.

Cycle selection 1 is programmable allowing the wash, dwell, rinse, and sani-dwell times to be changed from

the default settings. Refer to SERVICE PROGRAMMING for procedures on altering the pre-programmed times of cycle one.

NOTE: Cycle 1's times cannot be adjusted below the NSF minimums.

LUBRICATION

Component	Lubrication Type
Impeller O - Ring	P 80® Rubber Lube
Booster Heater Screws	Never Seez
All NPT Fittings	Pipe Thread Sealant, Loctite 565
High-Limit Thermostat 1TAS	Thermal-Joint Compound
High-Limit Thermostat 3TAS (Booster Option.)	Thermal-Joint Compound

TOOLS

- Standard set of hand tools.
- VOM with A/C current tester (any quality VOM with a sensitivity of at least 20K ohms per volt can be used).
- Anti Static Kit
- Temperature Tester.
- Clamp on type amp meter for measuring heating element current draw.

SERVICE PROCEDURES AND ADJUSTMENTS

CONTROL BOARD PROGRAMMING



WARNING Certain procedures in this section require electrical test or measurements while power is applied to the machine. Exercise extreme caution at all times and follow Arc Flash procedures. If test points are not easily accessible, disconnect power and follow Lockout/Tagout procedures, attach test equipment and reapply power to test.

NOTE: The control board is mounted in the machine in such a way that the printing is upside down. The control board will be depicted in the manual as it is found on the machine for consistency purposes.

NOTE: Prior to removing board from machine, check and note the settings of the programmable variables as outlined under SERVICE PROGRAMMING when possible. When unable to access Service Programming, check with establishment manager to determine customer control settings.

NOTE: The replacement control board will come programmed as a different model. Step through this procedure to set up the control board to function as an SD3.

1. Remove FRONT COVER.
2. Open control door.
3. Carefully short the two FACTORY pins of J5 together and press the ON key on switch membrane keypad (user controls on front of machine). Keep short across pins of J5 until display indicates [88], then remove the short.
 - A. Display will cycle between [SET ty] and [Sd, fd, GL, AS, HL, or St].

NOTE: SD3 machine type designation is [St].

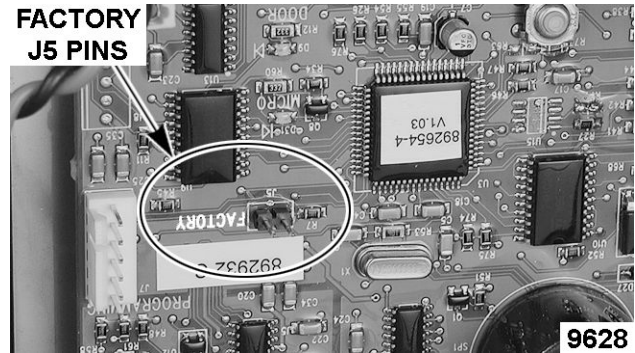

Fig. 1

4. Program the control board using the information retrieved from the board being replaced and the information found in CONTROL BOARD PROGRAMMING table.
5. Use the SELECT switch on control board to select the feature and the (up arrow) switch to change the feature settings.

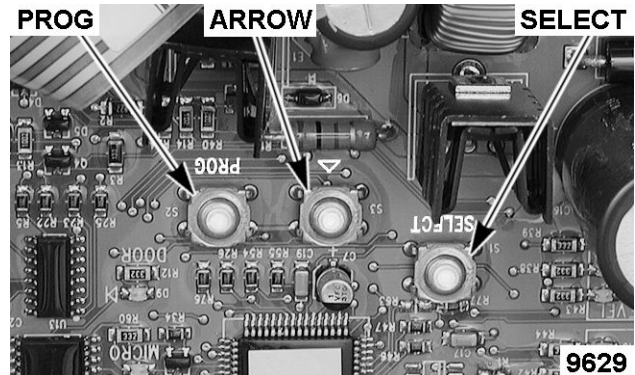

Fig. 2

NOTE: The display will alternate between the feature and setting.

6. Press OFF key on switch membrane keypad (user controls on front of machine) to store selections.
7. Program the variables. Refer to SERVICE PROGRAMMING.
8. Close control door.
9. Check machine for proper operation by running one fill cycle and two normal cycles.

CONTROL BOARD PROGRAMMING			
Feature Description	Display	Setting	Display
Machine Type	ty	Standard ¹	Sd
		Not Applicable in SD3	fd
		Not Applicable in SD3	GL
		Not Applicable in SD3	AS
		Not Applicable in SD3	HL
		SD3	St
ID	Id	Hot SD3 with Booster	H
		Chemical	C
		Plain SD3 No Booster	P
Rinse Assurance	tc	Yes ²	yE
		No	no
Manual Temperature Control	tr	These parameters are not available for SD3. If either one of these are displayed, return to MachineType and select [St].	
Flow Options	FL		
Diagnostics override	dG	Show Error Codes ²	1
		Disable Error Codes	2
Shorted water thermistor detections	SP	These parameters are not available for SD3. If either one of these are displayed, return to MachineType and select [St].	
¹ Default setting.			
² This feature is not available on SD3 - Plain or Chemical models.			

SERVICE PROGRAMMING



⚠ WARNING Certain procedures in this section require electrical test or measurements while power is applied to the machine. Exercise extreme caution at all times and follow Arc Flash procedures. If test points are not easily accessible, disconnect power and follow Lockout/Tagout procedures, attach test equipment and reapply power to test.

NOTE: Service programming mode can be accessed by two methods.

Entering Programming Mode When Machine is OFF

1. Remove front cover.
2. Open control door.
3. Press and hold the PROG switch on the control board, then press the ON key on the switch membrane keypad (user controls on front of machine) to enter programming mode.
 - A. Release PROG switch when display shows [88].

Entering Programming Mode When Machine is ON (Tank Temperature Displayed and Fill Cycle is Complete)

1. Remove FRONT COVER.
2. Open control door.
3. Press and hold the PROG switch on the control board, then press the CYCLE key on the switch membrane keypad (user controls on front of machine) to enter programming mode.
 - A. Release PROG switch when display shows [88].

Programming Mode

NOTE: Refer to SERVICE PROGRAMMING CHART.

1. Change each function setting by pressing the (up arrow) switch on board until correct value is entered.
2. Press the SELECT switch on the board to enter next function.

NOTE: Pressing the OFF key on display keypad at any time during programming will store your selections.

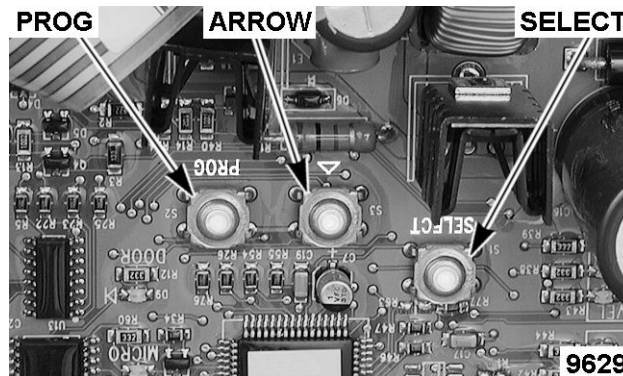

Fig. 3

3. To exit service programming and store your selections do one of the following:
 - A. Press OFF key (machine will shut down).
 - B. Press PROG switch (machine will stay on with tank temperature being displayed).
 - C. Close control door.
 - D. Check for proper operation by running one fill cycle and two normal cycles.

SERVICE PROGRAMMING CHART				
PARAMETER	DISPLAY		PROGRAMMING VARIABLES	DEFAULT
	ICONS	NUMERIC VALUE		
Tank Temperature	SET WASH	Programmed Temperature	Chemical Models: 120-150°F	130°F
			Hot Models: 150-170°F	158°F
			Plain Models: 150-170°F	158°F
Booster Temperature (Hot Machines Only)	SET RINSE	Programmed Temperature	180 - 195°F (Hot Models Only)	186°F
Cycle 1 Wash Time	SET WASH	Programmed Wash Time	38 - 99 seconds	38 sec.
Dwell Time (all cycles)	SET	[1dt] Alternating with Programmed Dwell Time	2 - 15 seconds	2 sec.
Rinse Time (all cycles)	SET RINSE	Programmed Rinse Time	10 - 15 seconds	10 sec.
Sani-dwell Time (all cycles)	SET	[dt] Alternating with Programmed Sani-Dwell Time	SD3 -H and -P 7 - 15 seconds	7 sec.
			SD3 - C dE = disabled; 1 - 15 seconds	dE
°F or °C Display	SET °F or °C	No Numeric Display	°F, °C	°F
Idle Shut Down Time	SET IdL	[IdL] Alternating with Programmed Shut Down Time in Hours	dE = 0 = disabled; 0 - 12 (hours)	6
Empty Water Level Detection ¹	SET	Present Sensitivity Setting	20 - 80	60
Clean Float Setting ¹	SET	Present Sensitivity Setting or [dE]	0 - 18	15

¹ Although parameter is adjustable, this setting has no affect on the float switch circuit of SD3 machines.

TANK HEATER - TEST



WARNING Certain procedures in this section require electrical test or measurements while power is applied to the machine. Exercise extreme caution at all times and follow Arc Flash procedures. If test points are not easily accessible, disconnect power and follow Lockout/Tagout procedures, attach test equipment and reapply power to test.

NOTE: Tank must be filled with water (float switch closed) in order to test tank heat circuit.

1. Remove FRONT COVER.
2. Open control door.
3. Apply power to machine.
 - A. Measure incoming voltage across line side of the tank contactor 2CON and verify it matches machine specifications on data plate.
4. Verify the following conditions are met.
 - A. Tank is full of water.
 - B. Float switch 1FS is closed.
 - C. Wash tank thermistor 1QTM is good, not open or shorted.
 - D. There is a demand for heat (tank water temperature is below set point).
5. Turn machine on.

NOTICE Shorting J8 terminals together without having water in the tank may result in damaging the tank heater.

- A. If temperature control circuit is not calling for heat (relay board TANK HEAT LED not lit), run machine through a cycle to activate tank heater. Alternately, short the relay board TANK HEAT (AM) -J8 pins together to energize the tank heater.

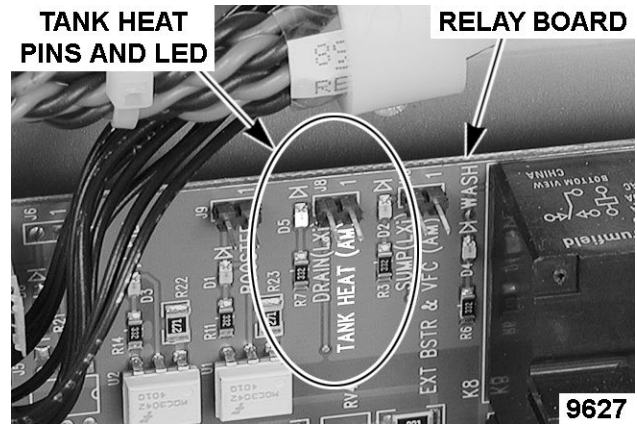

Fig. 4

6. While the TANK HEAT (AM) LED is on, verify that the tank heat contactor 2CON is energized.
 - A. If contactor is not energized, check for 120VAC across coil.
 - 1) If 120VAC is not present, check high limit thermostat 1TAS.
 - B. If contactor is energized, check:
 - 1) Voltage across all legs on load side of contactor.
 - 2) Current flow through all elements of heater.

RATED TANK HEATER ELEMENT CURRENTS		
Voltage/Phase	Amperes	Power (Watts)
208/60/1	26A	5.4kW
240/60/1	30A	7.2kW
208/60/3	15A	5.4kW
240/60/3	17.3A	7.2kW
480/60/3	6A	5kW

7. If the current reading on any of the elements is not correct:
 - A. Check the contacts of contactor 2CON.
 - B. Check the wash tank heater element resistance.

INDIVIDUAL TANK ELEMENT RESISTANCE	
Voltage	Cold Resistance
208 - 240V	21.7 - 25.1Ω
480V	105 - 121.7Ω

BOOSTER HEATER - TEST



WARNING Certain procedures in this section require electrical test or measurements while power is applied to the machine. Exercise extreme caution at all times and follow Arc Flash procedures. If test points are not easily accessible, disconnect power and follow Lockout/Tagout procedures, attach test equipment and reapply power to test.

NOTE: Tank must be filled with water (float switch closed) in order to test booster heat circuit.

1. Measure incoming voltage and verify it matches machine specifications.
2. Remove FRONT COVER.
3. Open control door.
4. Apply power to machine and booster.
 - A. Measure incoming voltage across line side of the tank contactor 2CON and booster contactor 3CON. Verify voltages match machine specifications on data plate.
5. Verify the following conditions are met.
 - A. Tank is full of water.
 - B. Float switch 1FS is closed.
 - C. Booster thermistor 3QTM is good, not open or shorted.
 - D. There is a demand for heat (booster water temperature is below set point).
6. Turn machine on.

NOTICE Shorting J9 terminals together without having water in the tank may result in damaging the tank heater.

- A. If temperature control circuit is not calling for heat (relay board BOOSTER LED not lit), run machine through a cycle to activate booster heater. Alternately, short the relay board pins BOOSTER - J9 together to energize the booster heater.

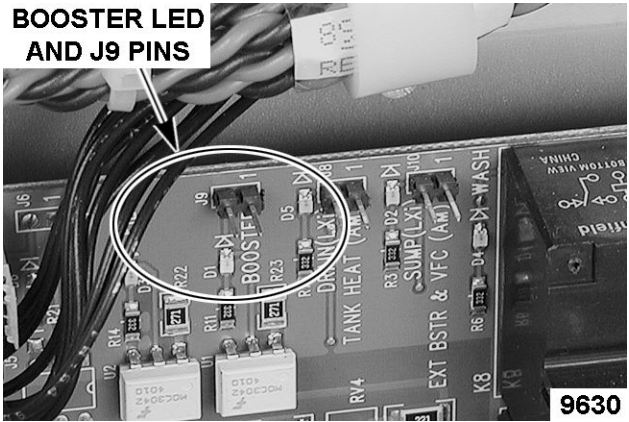

Fig. 5

7. While the BOOSTER LED is on, verify that the booster contactor 3CON is energized.
 - A. If contactor is not energized, check for 120VAC across coil.
 - 1) If 120VAC is not present, check high limit thermostats 2TAS and 3TAS.
 - B. If contactor is energized, check:
 - 1) Voltage across all legs on load side of contactor.
 - 2) Current flow through all elements of heater.

BOOSTER HEATER ELEMENT CURRENTS		
Voltage/Phase	Amperes	Power (Watts)
200/60/1	45.1A	9kW
208/60/1	40.7A	9.8kW
240/60/1	54.2A	13kW
200/60/3	26A	9kW
208/60/3	27.2A	9.8kW
240/60/3	31.3A	13kW
480/60/3	13.6A	13kW

8. If the current reading on any of the elements is not correct:
 - A. Check the contacts of contactor 3CON.
 - B. Check the booster heater element resistance.

INDIVIDUAL ELEMENT RESISTANCE	
Voltage	Cold Resistance
200 - 208V	9.0 - 10.5Ω
220 - 240V	12 - 13.9Ω
380 - 415	30.2 - 34.9Ω
440 - 480V	48.2 - 55.7Ω

INDIVIDUAL ELEMENT RESISTANCE	
Voltage	Cold Resistance
575 - 600V	75.3 - 87.0Ω

PUMP MOTOR - TEST



⚠ WARNING Certain procedures in this section require electrical test or measurements while power is applied to the machine. Exercise extreme caution at all times and follow Arc Flash procedures. If test points are not easily accessible, disconnect power and follow Lockout/Tagout procedures, attach test equipment and reapply power to test.

NOTE: The pump motor for all machines is rated at 2 H.P. and has thermal overload protection.

1. Remove FRONT COVER.
2. Open control door.
3. Apply power and measure incoming voltage verifying it meets machine requirements.
4. Turn machine on and take an amperage reading of one of the tank heater leads connected to contactor (2CON).

SD3 MOTOR CURRENTS (Maximum)	
Voltage/phase	Amps
208/60/1	11.0A
240/60/1	10.6A
208/60/3	5.6A
240/60/3	5.4A
480/60/3	2.7A

NOTE: Current consumption for a normally operating pump and motor assembly will be less than the amperage values listed.

5. If motor current exceeds those values listed in the table, inspect pump for blockage causing a locked-rotor condition.
 - A. If blockage is not present, replace motor.
6. If current in one phase of a three phase motor is low or missing, also inspect incoming line service, contactor 1CON and other related circuitry to missing phase.

THERMISTOR - TEST 1QTM, 2QTM & 3QTM



⚠ WARNING Certain procedures in this section require electrical test or measurements while power is applied to the machine. Exercise extreme caution at all times and follow Arc Flash procedures. If test points are not easily accessible, disconnect power and follow Lockout/Tagout procedures, attach test equipment and reapply power to test.

NOTE: The temperature/resistance characteristics are the same for all the thermistors used in SD3.

NOTE: The resistance of each thermistor can be measured by removing the plug connected to J2 on the control board.

1. Remove FRONT COVER.
2. Open control door.

Quick Check Using Service Diagnostics

1. Enter Service Diagnostics mode.
 - A. Apply power. With machine off, press and hold the PROG and SELECT switches on control board and press and release the ON key on the switch membrane keypad.
 - B. Continue to hold in on the PROG and SELECT switches until display shows [88] then release both switches.

NOTE: XXX represents the actual water temperature.

- C. Press the SELECT switch repeatedly until [WASH XXX°F (°C)] which is tank water temperature.
- D. Press the SELECT switch once to display [XXX°F (°C) RINSE] which is rinse water temperature.
- E. Press the SELECT switch once to display [WASH XXX°F (°C) RINSE] which is booster water temperature.

Measuring Thermistor Resistance

1. Disconnect the plug from J2 on the control board.

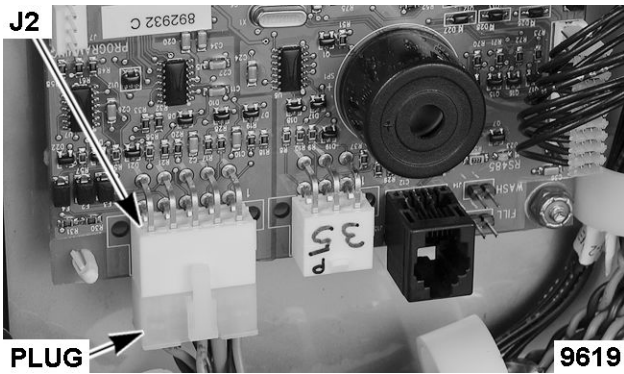

Fig. 6

- Refer to the following photograph to locate the thermistor leads of interest.

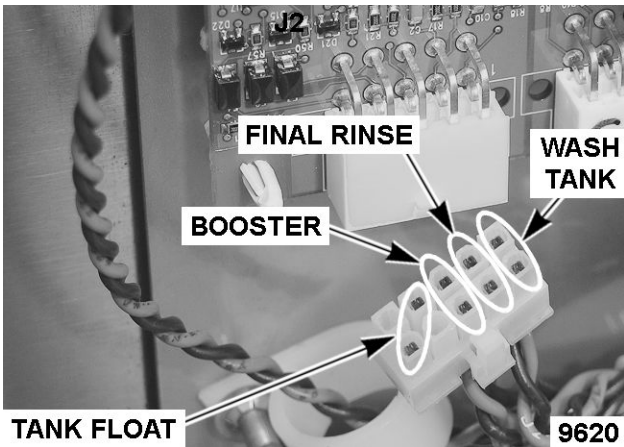

Fig. 7

PINS FOR THERMISTORS AND FLOAT SWITCH

- Refer to the table that follows for thermistor resistance values.

TEMPERATURE VS. RESISTANCE FOR 1QTM, 2QTM AND 3QTM THERMISTORS	
DEGREE (°F)	RESISTANCE (Ω)
70°F	120 kΩ
80°F	91 kΩ
90°F	72 kΩ
100°F	55 kΩ
110°F	44 kΩ
120°F	34.5 kΩ
130°F	28 kΩ
140°F	22.5 kΩ
150°F	18 kΩ
160°F	14.5 kΩ
170°F	12 kΩ
180°F	10 kΩ

TEMPERATURE VS. RESISTANCE FOR 1QTM, 2QTM AND 3QTM THERMISTORS	
DEGREE (°F)	RESISTANCE (Ω)
190°F	8.2 kΩ
200°F	6.9 kΩ
210°F	5.8 kΩ
250°F	2.9 kΩ
257°F	2.626 kΩ
284°F	1.734 kΩ
290°F	1.6 kΩ

TRANSFORMER 1T - TEST



WARNING Certain procedures in this section require electrical test or measurements while power is applied to the machine. Exercise extreme caution at all times and follow Arc Flash procedures. If test points are not easily accessible, disconnect power and follow Lockout/Tagout procedures, attach test equipment and reapply power to test.

NOTE: Transformer 1T steps down incoming line voltage to 120VAC for use by the machine's control components.

- Remove FRONT COVER.
- Open control door.
- Remove right side cover.
- Verify transformer is strapped correctly by comparing connection wiring points on transformer with machine data plate.

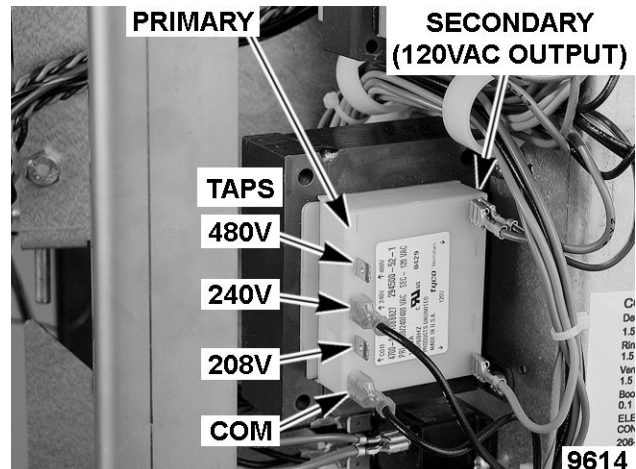

Fig. 8

5. Connect power to machine.
6. Verify incoming AC line voltage at the line service connection point.
7. Verify incoming voltage is present to primary side of transformer 1T.
8. Measure output AC voltage across secondary windings of transformer. Voltage should be approximately 120VAC.
 - A. If voltage is present, transformer is functioning.
 - B. If output voltage is not present, verify transformer wiring connections.
 - 1) If connections are correct, replace transformer.
 - C. If output voltage is low, disconnect power from machine.
 - 1) Disconnect one side of the secondary.
 - 2) Apply power to machine.
 - 3) Check output voltage across secondary windings.
 - a. If voltage is still low, replace transformer.
 - b. If voltage is approximately 120VAC, check components and related wiring connected to the secondary.

TRANSFORMER 2T - TEST



⚠ WARNING Certain procedures in this section require electrical test or measurements while power is applied to the machine. Exercise extreme caution at all times and follow Arc Flash procedures. If test points are not easily accessible, disconnect power and follow Lockout/Tagout procedures, attach test equipment and reapply power to test.

1. Remove FRONT COVER.
2. Open control door.
3. Remove right side cover.
4. Connect power to machine.
5. Verify incoming 120VAC voltage is present to primary side of transformer 2T.

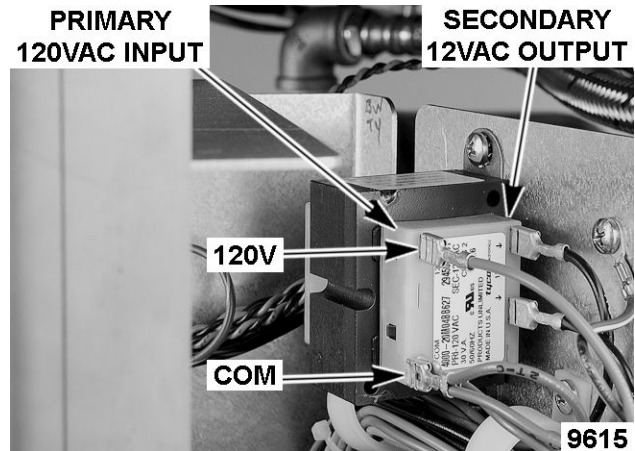

Fig. 9

- A. If 120VAC is not present, check fuse F2 on relay board.
 - 1) If fuse is good, perform TRANSFORMER 1T - TEST.
6. Measure output AC voltage across secondary windings of transformer. Voltage should range between (11.5 - 16VAC).

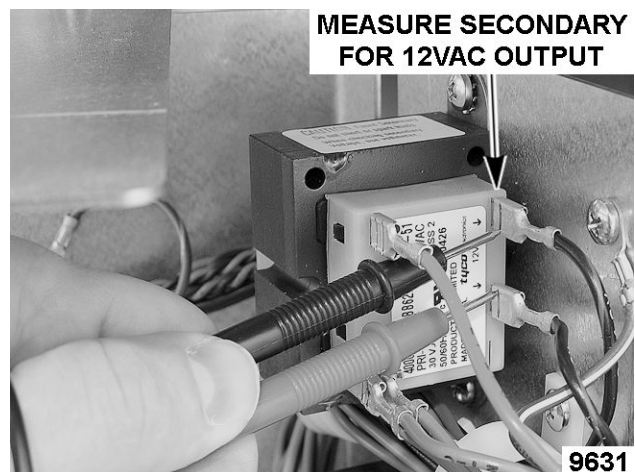

Fig. 10

- A. If voltage is present at output, transformer is functioning.
- B. If voltage is not present at output, verify transformer wiring connections.
 - 1) If connections are correct, replace transformer.
- C. If voltage is low, disconnect power from machine.
 - 1) Disconnect one side of the secondary.
 - 2) Apply power to machine.
 - 3) Check voltage across secondary windings.

- a. If voltage at output is still low, replace transformer.
 - b. If voltage at output is between 11.5 - 16VAC, check the control board assembly.
3. Lock adjusting nut in position with lower nut.

DELIMING PROCEDURE

⚠ WARNING DELIMING SOLUTION, RINSE AGENTS, OR ANY OTHER KIND OF ACID MUST NOT COME IN CONTACT WITH BLEACH OR RINSE SOLUTION CONTAINING BLEACH USED IN CHEMICAL SANITIZING MACHINES. MIXING MAY CAUSE HAZARDOUS GAS TO FORM. THIS ENTIRE PROCEDURE MUST BE FOLLOWED STEP-BY-STEP FOR SAFE AND SATISFACTORY RESULTS.

1. Remove rack, drain tank, press "OFF".
2. Press and hold "Cycle & "ON for three seconds.
3. Open door & add delime agent per supplier instructions for 14 gallon tank.
4. Close door, pump starts & display flashes "DELIME". After 12 minutes display scrolls "DRAIN".
5. Check interior, close door to run additional cycles if necessary.
6. Drain tank, turn unit off.

NOTE: The delime counter feature is disabled from the factory.

DOOR TENSION ADJUSTMENT

NOTE: Door is adjusted correctly if the door remains in place at any position.

1. Loosen lock nut.

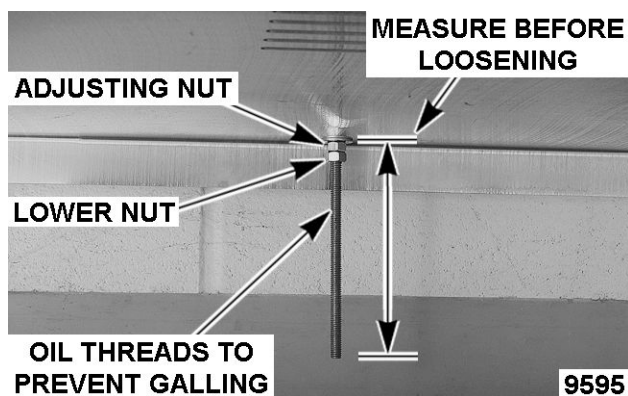

Fig. 11

2. Holding the spring rod in position to prevent rotation, adjust the nut to provide proper tension.

ELECTRICAL OPERATION

COMPONENT FUNCTION

Control Board Assembly	Controls dishwasher electrical operation.
Relay Board	Controlled by control board assembly, the on board relays and fuses deliver energy to machine control components.
Fuse, Relay Board (F1)	1/10A fuse. Protects rinse feeder 1CR coil circuit.
Fuse, Relay Board (F2)	1.0A fuse. Protects primary of transformer 2T, 1CON, 2CON, 3CON, 1SOL and external booster control from over-currents.
Switch Membrane Keypad	User interface to machine. Used to select wash mode and program control board assembly.
Display Module	Provides machine information to user through the use of LEDs, lighted icons, and illuminated text and numbers.
Contactor (1CON)	Controls electrical power to wash pump (120VAC coil).
Contactor (2CON)	Controls electrical power to wash tank heater (120VAC coil).
Contactor (3CON)	Controls electrical power to booster heater (120VAC coil).
Relay (1CR)	Controlled by the control board assembly through the relay board, provides a means of controlling energy to RPS1 and RPS2 on terminal block 3TB.
Float Switch (1FS)	Detects water level in tank. On SD3, control board only uses Low Water Level LED with the float switch.
Heater, Booster (BSTR HTR)	Heating element for booster (8.5kW).
Heater, Tank (Tank HTR)	Heating element for wash tank (5kW to 7.2kW).
High Limit Thermostat (1TAS)	Protects tank heater circuit.
High Limit Thermostat (2TAS)	Protects booster circuit. Frame mounted, capillary design
High Limit Thermostat (3TAS)	Protects booster circuit. Mounted on the booster.
Interlock Switch (1LS)	Feed back to control board on state of door (open or closed).
Solenoid (1SOL)	Fill/rinse solenoid.
Thermistor, Wash (1QTM)	Senses tank water temperature.
Thermistor, Rinse (2QTM)	Senses rinse water temperature
Thermistor, Booster (3QTM)	Senses booster water temperature
Terminal Block (1TB)	Line service to tank contactor 2CON (1 phase only).

- Terminal Block (2TB)** Line service to booster contactor 3CON (1 phase only).
- Terminal Block (3TB)** Connection point for detergent and rinse aid control devices.
- Transformer (1T)** Provides 120VAC to control circuit and 2T.
- Transformer (2T)** Provides 12VAC to control board.

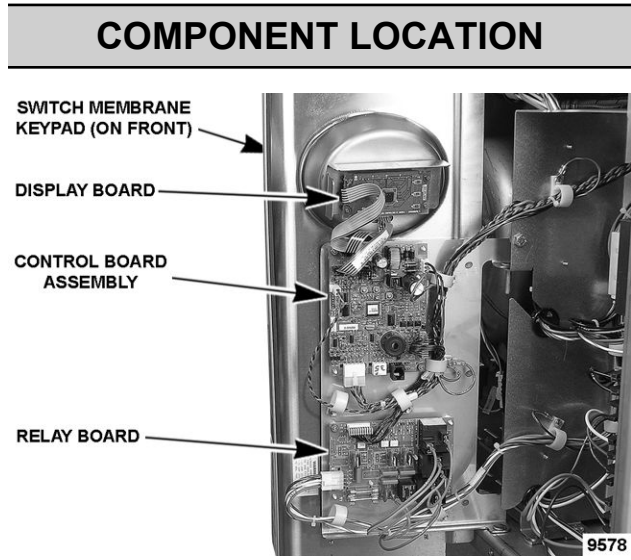

Control Door Mounted Components

NOTE: The components present are determined by the voltage, hertz, phase, and options on the dishwasher.

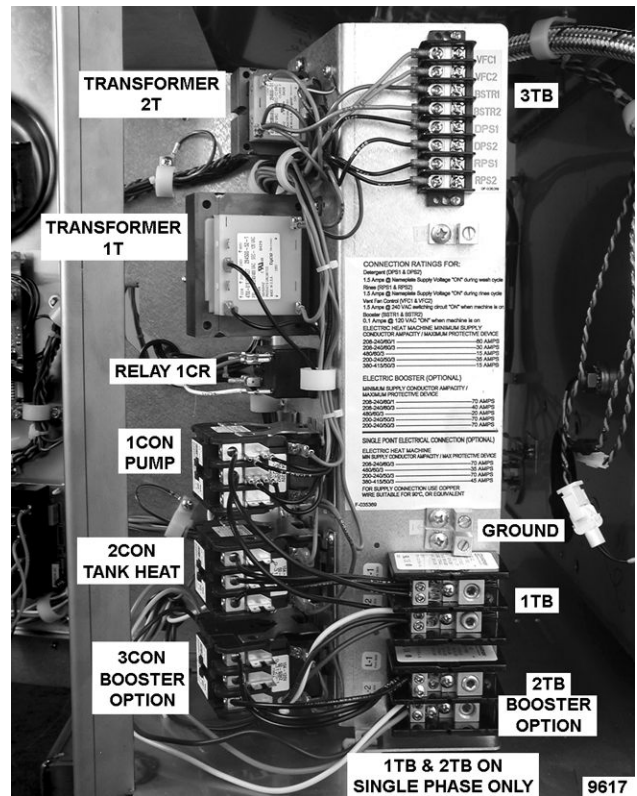

Control Panel Mounted Components

CONTROL BOARD / RELAY BOARD LAYOUT

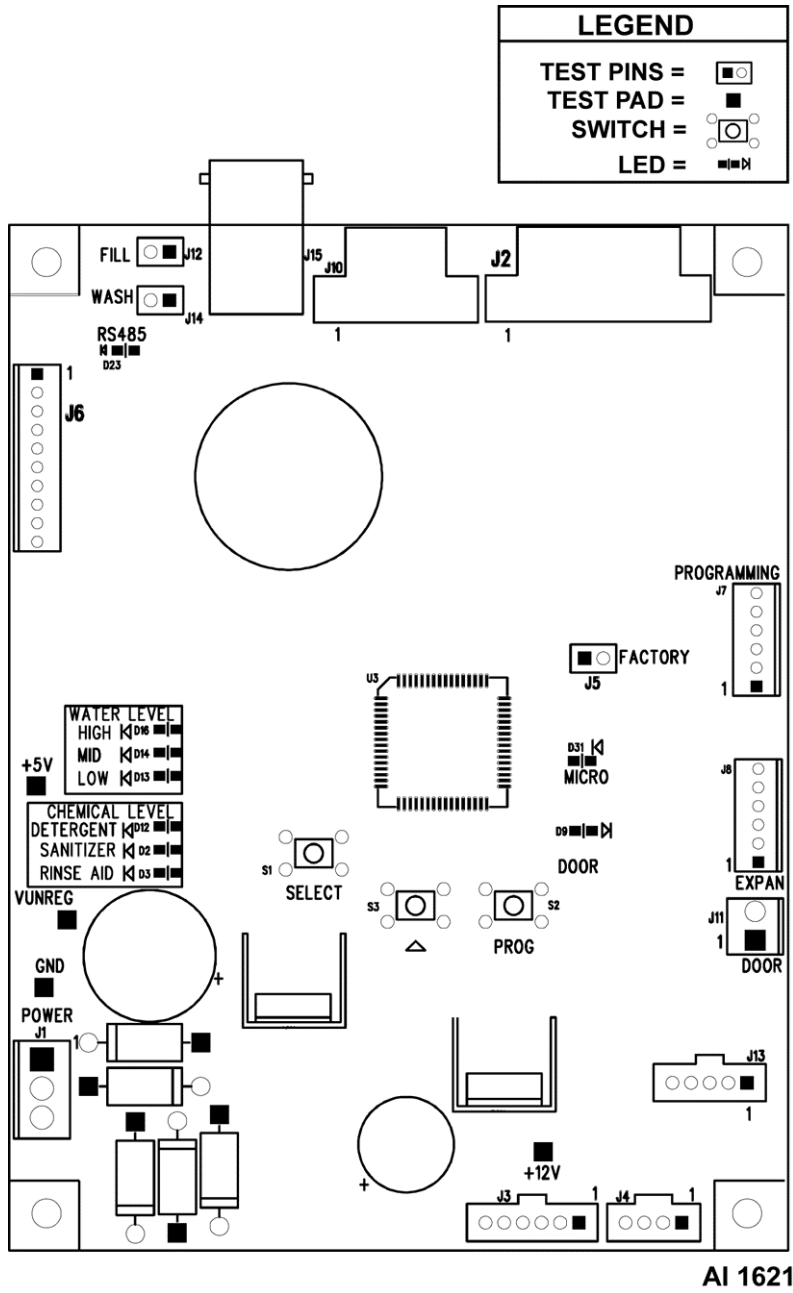

Control Board

**DETERGENT AND RINSE AID CIRCUITS
FOUND ONLY ON SERVICE REPLACEMENT BOARDS**

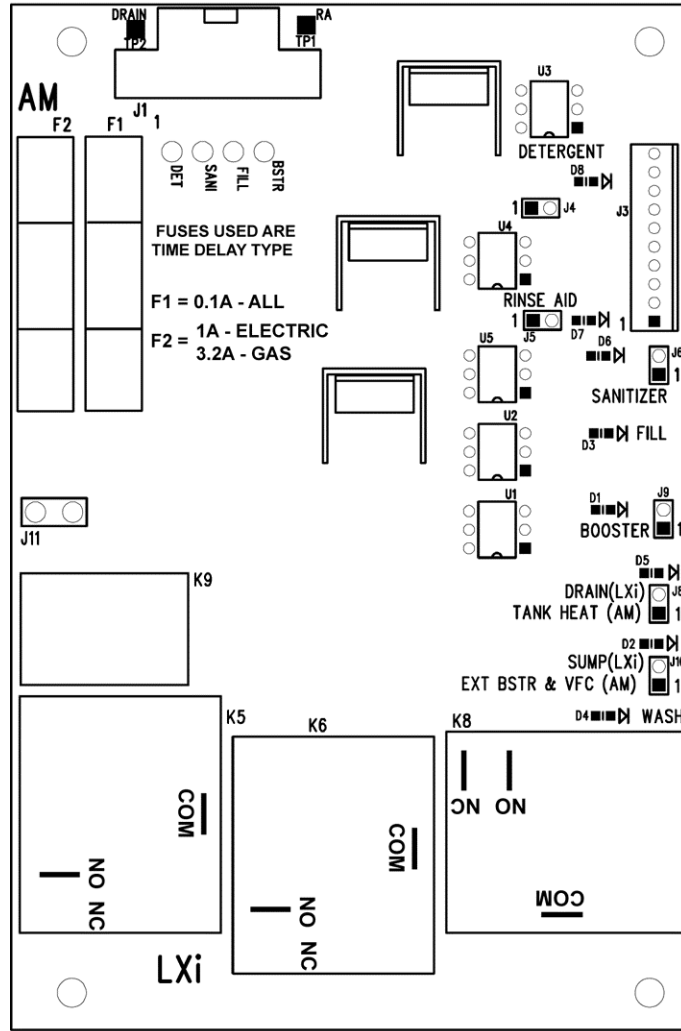

AI-1622

Relay Board

NOTE: DETERGENT AND RINSE AID CIRCUITS NOT USED ON SD3.

SEQUENCE OF OPERATION

Refer to the correct wiring diagram for model being serviced when reviewing sequence of operation.

WIRING DIAGRAM - 3 PHASE

WIRING DIAGRAM - 1 PHASE

Initial Conditions

- Door up (Door Interlock 1LS open).
- Dishwasher tank empty (Float 1FS open).
- Water supply requirements (110°F @ 20 ± 5 psi) to machine are satisfied.
- Voltage supplied to machine is correct.
- High limits are closed.

1. Machine is off. Display is not lit.
 - A. Line voltage present at the following components.
 - 1) Primary windings of transformer 1T.
 - 2) Line sides of 1CON (pump motor) and 2CON (tank heater).
 - 3) Booster heater line side of 3CON.
 - 4) Relay terminals 1CR 4 and 8.
 - B. 120VAC from transformer 1T present at the following components.
 - 1) Triac Q2 (1CR coil) thru fuse F1.
 - 2) Primary windings of transformer 2T thru fuse F2.
 - 3) Triac Q3 (3CON coil) thru fuse F2.
 - 4) Triac Q4 (1SOL) thru fuse F2.

- 5) Relay board relays K5-C, K8-C and K9-C thru fuse F2.

NOTE: It is normal for the secondary voltage (output) from transformer 2T to range between 11.5 to 16VAC.

- C. 12VAC present to control board J1-1/3 from secondary windings of transformer 2T. Acceptable voltage is 11.5 - 16VAC.
 - 1) Power supply on control board converts AC voltage to 12VDC and 5VDC to power control board, display and membrane switch.
2. ON key on membrane switch is pressed.
 - A. Control board enters self-test, also tests display LEDs.
 - B. K5 coil on relay board energize.
 - 1) EXT BSTR & VFC (AM) LED on relay board turns on.
3. Self-test completes.
 - A. Machine type (AP, AH or AC) is displayed followed by tank temperature.
 - B. MICRO LED on control board blinks at a 1 second on - 1 second off rate.
 - C. 5VDC present across 1QTM, 2QTM, 3QTM and open contacts of 1FS.
 - D. Tank temperature is displayed.
 - E. Membrane switch - last selected cycle LED is on. Cycle selection is enabled.
4. Door is shut.
 - A. Door interlock switch 1LS closes.
 - B. Control board senses float switch is open and energizes fill/rinse solenoid 1SOL through relay board. Tank begins to fill.
 - 1) FILL LED on relay board turns on.
 - C. FILL icon and tank temperature are displayed on display board.

NOTE: Once tank float switch is closed, a wash cycle can be started by opening and closing the door even though fill is not complete.

- D. Tank float 1FS closes.
 - 1) LOW LEVEL WATER LED on control board turns on.
 - 2) Control board energizes 3CON coil through the relay board. 3CON contacts close energizing booster heater.

- a. BOOSTER LED on relay board turns on.
 - 3) Control board signals relay board (relay K9) to energize 2CON coil. 2CON contacts close energizing tank heater.
 - a. TANK HEAT (AM) LED on relay board turns on.
 5. Depending on the fill time required to close float switch 1FS, the control board will fill an additional amount of time (75 - 120 seconds) after which time the control board de-energizes the fill/rinse solenoid 1SOL through the relay board.
 - A. FILL LED on relay board turns off.
- NOTE:** Tank Heat and Booster circuits remain energized until set point has been reached; however, a wash cycle may be started at any point.
6. Booster temperature reaches set-point.
 - A. Control board de-energizes 3CON coil through the relay board. 3CON contacts open de-energizing booster heater.
 - 1) BOOSTER LED on relay board turns off.
 7. Tank temperature reaches set-point.
 - A. Control board de-energizes 2CON coil through the relay board. 2CON contacts open de-energizing tank heater.
 - 1) TANK HEAT (AM) LED on relay board turns off.
 8. Door is opened and closed.
 - A. Control board senses that float switch 1FS was closed before the door was closed and energizes relay K8 on relay board. 1CON contacts close energizing the pump motor MTR. A wash cycle begins.
 - 1) WASH LED on relay board turns on.
 - 2) Machine line voltage present at terminals DPS1 and DPS2.
 9. Wash cycle.
 - A. The WASH icon and water temperature are displayed.
 - B. Wash cycle continues for time selected.
 - C. Wash cycle completed.
 - 1) Relay board K8 de-energizes. Wash coil (1CON) de-energizes and pump N.O. contacts open. Pump stops.

- a. WASH LED on relay board turns off.
 - 2) Dishwasher enters a dwell cycle. Default is two seconds.
 - 3) Machine line voltage removed from terminals DPS1 and DPS2.
- D. Rinse cycle begins.
- 1) Control board energizes the fill/rinse solenoid (1SOL) through the relay board.
 - a. FILL LED on relay board turns on.
 - 2) Control board energizes the rinse feeder relay coil (1CR) through the relay board. Relay 1CR N.O. contacts 4/2 and 8/6 operate (close).
 - 3) The RINSE icon and final rinse temperature are displayed.
 - 4) Machine line voltage present at terminals RPS1 and RPS2.
 - 5) Rinse cycle continues for the programmed time. Default is 10 seconds.
- E. Rinse cycle completed.
- 1) Control board enters seven second sani-dwell. RINSE icon is displayed until sani-dwell cycle is complete.
 - 2) Control board de-energizes the rinse feeder 1CR through the relay board. Relay 1CR de-energizes and 1CR N.O. contacts 4/2 and 8/6 open.
 - 3) Control board de-energizes the fill/rinse solenoid 1SOL through the relay board. Rinsing stops.
 - a. FILL LED on relay board turns off.
 - 4) Machine line voltage removed from terminals RPS1 and RPS2.
 - 5) Tank temperature is displayed.
10. Tank Heat and Booster temperatures continue to be monitored and maintained by the control board through the relay board.

CONTROL and RELAY BOARD LEDs

CONTROL BOARD LEDs	
CONTROL BOARD	DESCRIPTION
DOOR	On when door interlock 1LS is closed.
MICRO	Flashes at a rate of 1sec on, 1 sec off when machine is on.
WATER LEVEL	LOW - On when float switch 1FS is closed.
	MID - Not used with SD3.
	HIGH - Not used with SD3
RS485	Used with NAFEM Gateway.

RELAY BOARD LEDs	
RELAY BOARD	DESCRIPTION
BOOSTER	On when triac Q3 (booster circuit) is gated on. Booster heat on.
FILL	On when triac Q4 (fill circuit) is gated on. 1SOL on.
TANK HEAT AM	On when K9 is energized. Tank heat on.
EXT BSTR & VFC	On when machine is on.
WASH	On when K8 is energized. Pump motor on.
RINSE AID	On when triac Q2 (rinse feeder) is gated on. 1CR is energized.

RELAY BOARD LEDs	
RELAY BOARD	DESCRIPTION
DETERGENT SANITIZER	LEDs present on service replacement relay boards, but not used on SD3 machines.

WIRING DIAGRAM - 1 PHASE

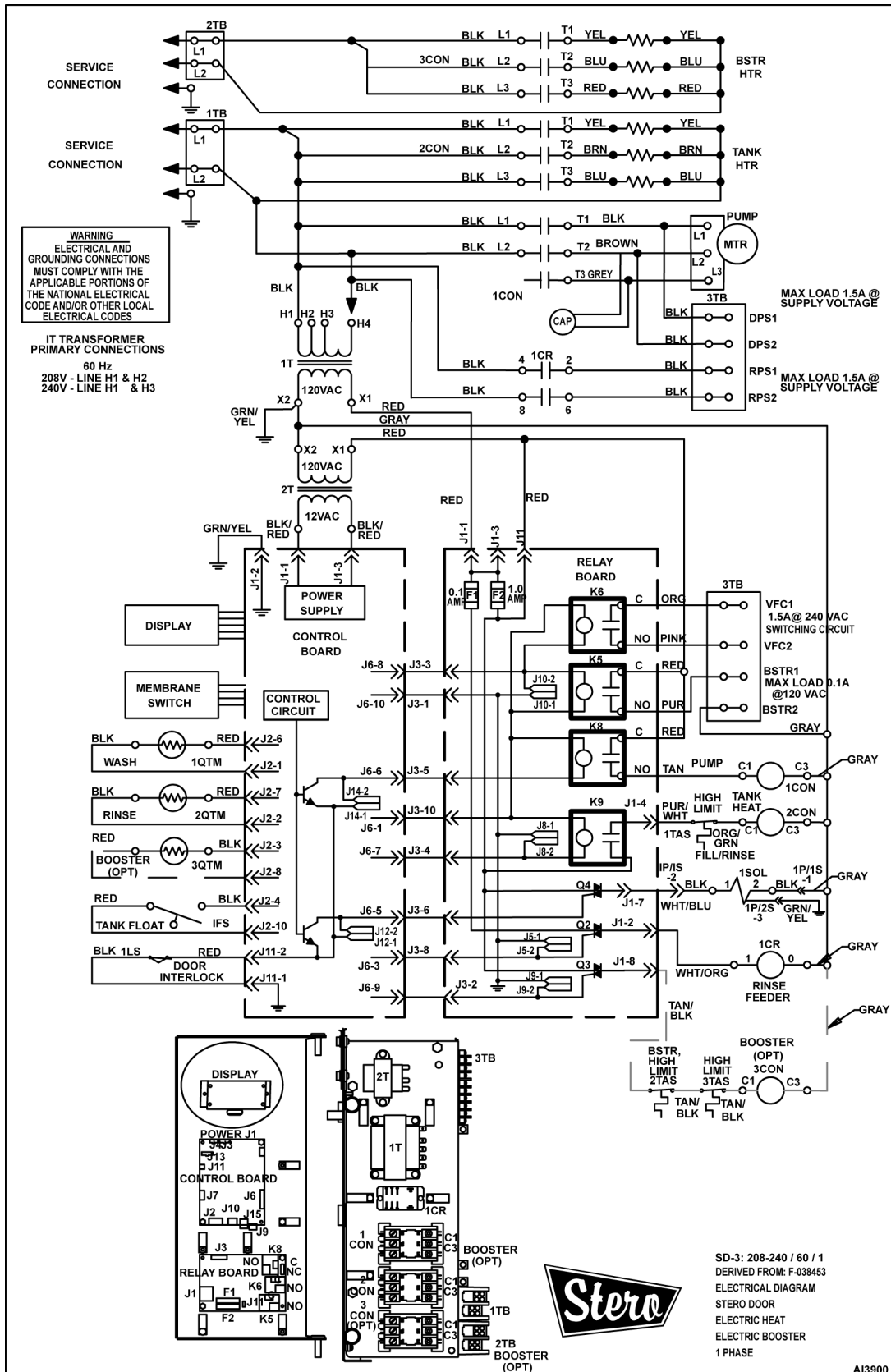

Fig. 16

WIRING DIAGRAM - 3 PHASE

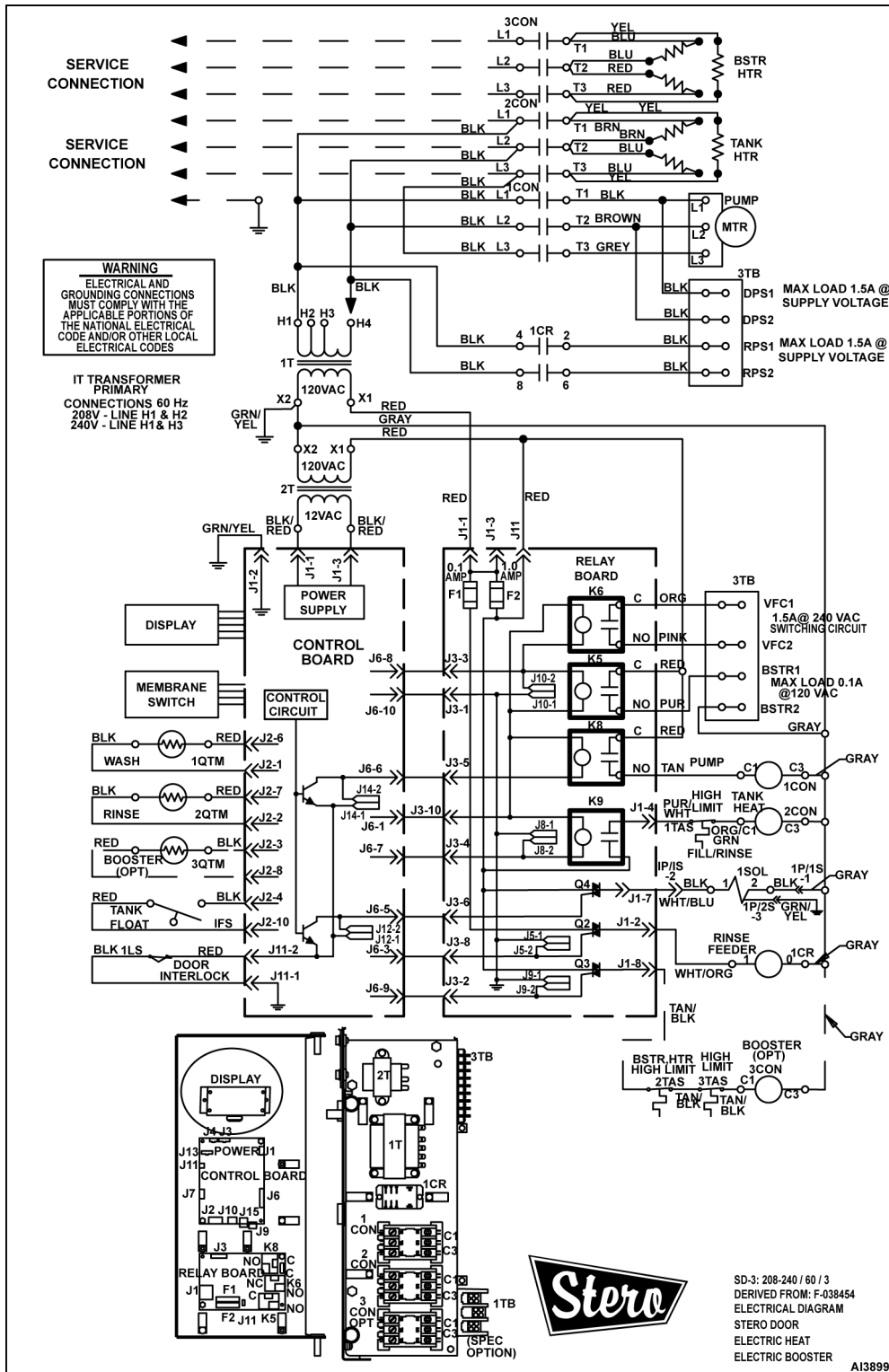

Fig. 17

TROUBLESHOOTING

QUICK REFERENCE CHART - ELECTRIC HEAT

ELECTRIC HEAT CHART					
Component Under Test	Test Point	Measure			
Transformer - 1T	Primary H1 & H2	208V Line Service			
	Primary H1 & H3	240V Line Service			
	Primary H1 & H4	480V Line Service			
	Secondary X1 & X2	120VAC			
Transformer - 2T	Primary X1 & X2	120VAC			
	Secondary BLK/RED, BLK/RED	11.5 - 16VAC			
Booster Heater	Element Leads (Cold Resistance)	220-240V	12 - 13.9Ω		
		440 - 480V	48.2 - 55.7Ω		
	Element Leads (amperes)	208/60/1	26A	5.4kW	
		240/60/1	30A	7.2kW	
		208/60/3	15A	5.4kW	
		240/60/3	17.3A	7.2kW	
		480/60/3	6A	5kW	
Tank Heater	Element Leads (Cold Resistance)	208-240V	21.7 - 25.1Ω		
		480V	105 - 121.7Ω		
	Element Leads (amperes)	208/60/1	26A	5.4kW	
		240/60/1	30A	7.2kW	
		208/60/3	15A	5.4kW	
		240/60/3	17.3A	7.2kW	
		480/60/3	6A	5kW	
Pump Motor	Motor Leads (amperes)	208/60/1	11.0A		
		240/60/1	10.6A		
		208/60/3	5.6A		
		240/60/3	5.4A		
		480/60/3	2.7A		
Control Board VDC reference to group unless otherwise stated)	J1-1/K1-3 Input Voltage	11.5 - 16VAC (present with power to machine)			
	J1-2	Ground (frame)			
	VUNREG (Test Pad)	14-19VDC (present with power to machine)			
	+ 12VDC (Test Pad)	12VDC (machine on)			
	+ 5VDC (Test Pad)	5VDC (machine on)			

ELECTRIC HEAT CHART		
Component Under Test	Test Point	Measure
Change Reference to +5VDC test pad for J6-3 to J6-9	J3-2 (Display)	12VDC (machine on)
	J3-1 (Display)	5VDC (machine on)
	J4-4 (Keypad)	5VDC (machine off only)
	J4-3 (Keypad)	5VDC (machine on)
	J4-2 (Keypad)	5VDC (machine on)
	J6-1	5VDC (machine on)
	J6-6 ®. Feed) J6-5 (Fill 1SOL) J6-6 (Pump) J6-7 (Tank Htr) J6-8 (BSTR & VFC) J6-9 (Booster)	5VDC (when circuit is active - component energized)
	J2	See Thermistor / Float Switch
	J11	See Door Interlock 1LS
	Relay Board (VDC reference to ground unless otherwise stated)	F1 & X2
F2 & X2		120VAC both sides of fuse
J3-10		5VDC (machine on)
K5-NO & X2		120VAC (machine on)
K6-C/NO		Continuity (machine on)
K8-NO & X2		120VAC (during wash cycle)
J1-2		120VAC (during rinse)
J1-4		120VAC (tank calling for heat)
J1-7		120VAC (during fill/rinse)
J1-8		120VAC (BSTR calling for heat)
J3-1		Ground
Change Reference to +5VDC test pad for J3-2 to J3-8		J3-2 (Booster) J3-3 (BSTR & VFC) J3-4 (Tank Htr) J3-5 (Pump) J3-6 (Fill 1SOL) J3-8 ®. Feeder)

ELECTRIC HEAT CHART		
Component Under Test	Test Point	Measure
Thermistors	Disconnect connector from J2 to measure resistance 1QTM = J2-1 / J2-6 2QTM = J2-2 / J2-7 3QTM = J2-3 / J2-8	100°F = 55.7kΩ
		120°F = 34.9kΩ
		140°F = 22.6kΩ
		158°F = 15.5kΩ
		160°F = 14.9kΩ
		180°F = 10.1kΩ
		200°F = 7kΩ
		212°F = 5.6kΩ
Float Switch	1FS = J2-4 / J2-10	Continuity
Door Interlock	1LS = J11-1 / J11-2	Continuity

CONTROL BOARD AND RELAY BOARD LEDS

CONTROL BOARD	
Control Board	Description
DOOR	On when door interlock 1LS is closed.
MICRO	Flashers at a rate of 1 sec on, 1 sec off when machine is on.
WATER LEVEL	LOW - On when float switch 1FS is closed.
RS485	Use with NAFEM Gateway

RELAY BOARD	
Relay Board	Description
BOOSTER	On when triac Q3 (booster circuit) is gated on.
FILL	On when triac Q4 (fill circuit) is gated on. 1SOL on.
TANK HEAT	On when K9 is energized. Tank heat on.
EXT BSTR & VFC	On when machine is on.
WASH	On when K8 is energized. Pump motor on.
RINSE AID	On when triac Q2 (rinse feeder is gated on. 1CR is energized.
DETERGENT SANITIZE	LEDs present on service replacement relay boards, nut no used on SD3.

CONTROL BOARD AND RELAY BOARD

NOTICE On dishwashers equipped with the optional booster, the heat circuit is enabled when tank float switch is closed. Do not operate machine with dishwasher tank full of water and booster tank empty.

NOTE: The SD3 dishwasher uses the same control board assembly as some other models. The control board must be programmed as an SD3 for the machine to function properly. Most SD3 related problems can be found quickly by using the on-board LEDs as a diagnostic tool.

NOTE: The control board is mounted in the machine in such a way that the printing is upside down. The control board will be depicted in the manual as it is found on the machine for consistency purposes.

Operating Conditions

- Refer to the proper wiring diagram for the model being serviced.
- Power is present to machine. The control board is configured to the machine data plate to operate as an SD Hot (H) or Plain (P) machine.
- Correct water supply to machine, turned on and at correct pressure (20 psi ± 5 psi).
- Control board is properly grounded.

No Display After ON Key is Pressed

1. Press the ON key on switch membrane keypad.
 - A. If display does not turn on, but all Cycle LEDs on keypad are lit for a brief time, then one of the Cycle LEDs remains lit, check the display board.
 - B. If there is no action on display and keypad. Verify:
 - 1) Switch membrane keypad is plugged into control board (two connectors).
 - 2) Display board is plugged into control board.
 - 3) Fuse F2 on relay board is good.
 - 4) Input voltage to control board is present (11.5 - 16VAC) across 1PL 1/3.

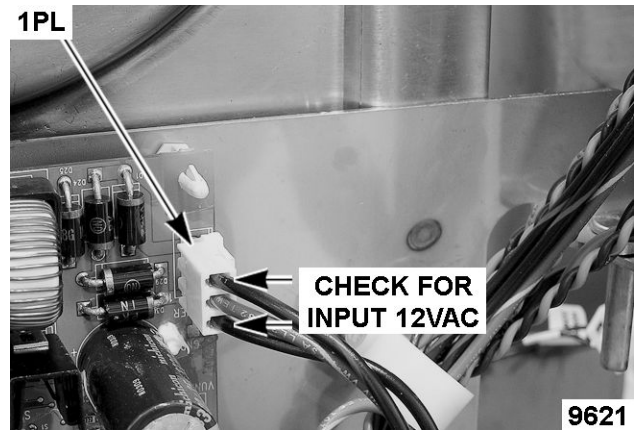

Fig. 18

- a. If voltage is not present, check transformer 2T.

- 5) VUNREG on control board has voltage present (14 - 19VDC).

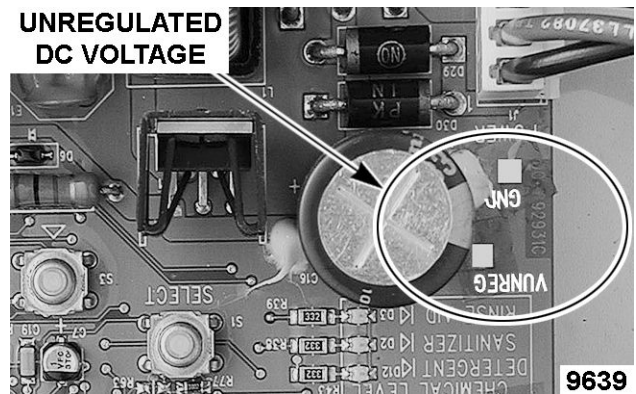

Fig. 19

- a. If voltage is not present, verify that the connector is connected correctly to J1 on control board. If it is correct, replace control board.

- 6) 5VDC at keypad connector J4-4.

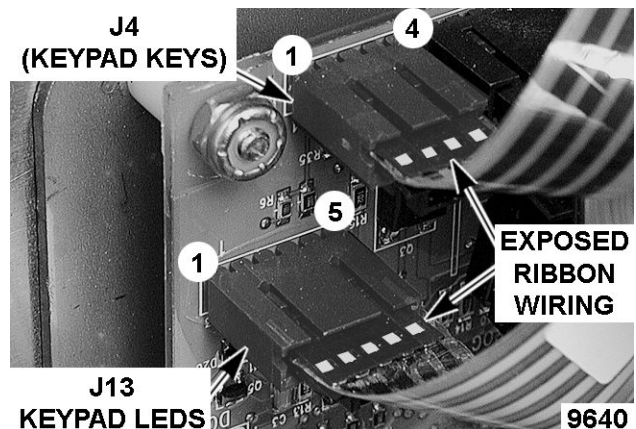

Fig. 20

- a. If voltage is not present, remove ribbon cable connector and check for 5VDC on pin J4-4. If not present replace control board.
- b. If voltage is present at J4-4 press and release the ON key on keypad. Voltage should drop to zero on J4-4 and remain at zero until machine is turned off.
 - a) If voltage does not drop to zero or a few millivolts after ON key is pressed, keypad has malfunctioned.
- c) If 12VDC is missing, disconnect the display board ribbon cable from the control board. Recheck. If 12VDC is present, display board has malfunctioned.

No Fill or Rinse

1. Press the ON key on keypad to turn on machine.
2. Verify the following.
 - A. OPERATING CONDITIONS are satisfied as stated at the beginning of this section.
 - B. Control board is programmed to operate as an SD3.
 - C. Wash tank is empty or water level is below float.
 - 1) Float switch 1FS is open.
 - D. Chamber door is closed.
 - E. MICRO LED on control board is flashing at a rate of 1 sec on 1 sec off.
 - F. DOOR LED on control board is on.

NOTE: If the MICRO LED remains on or off constantly when 5VDC is present on test pad, replace the control board.

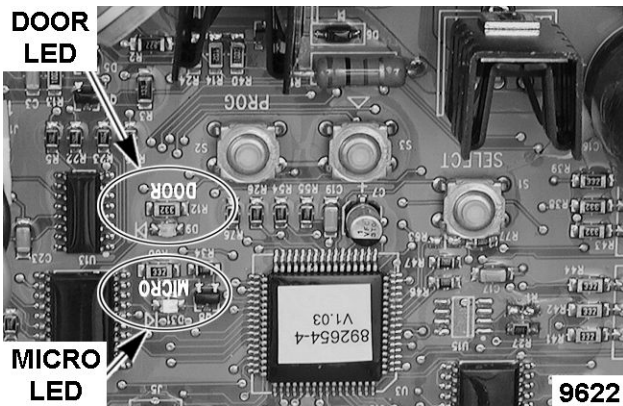

Fig. 21

- b) If voltage drops to zero or just a few millivolts after ON key is pressed, check for +12VDC and +5VDC on the test pads of control board.

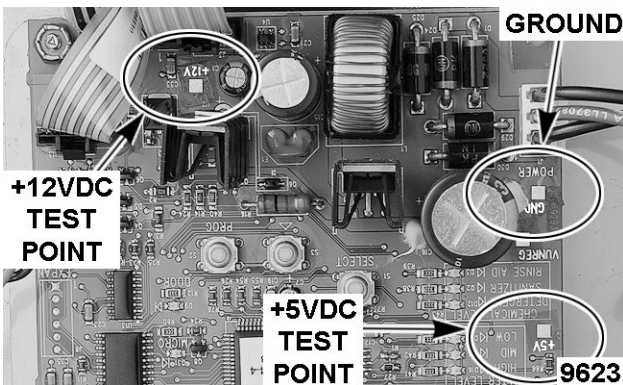

Fig. 22

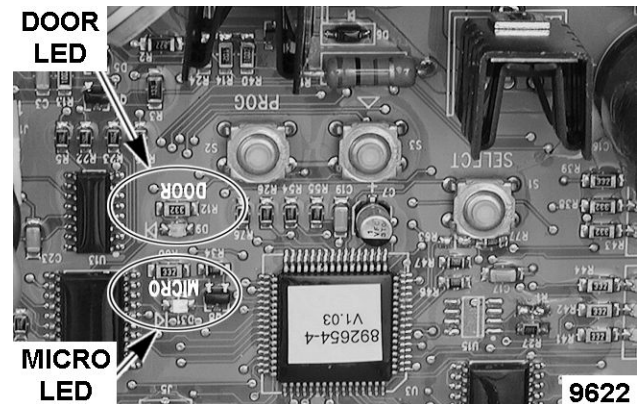

Fig. 23

- 1) If DOOR LED is not on with door closed, check door interlock switch, 1LS circuit.

NOTE: With the above conditions satisfied, the fill/rinse circuit should be active (1SOL energized). The FILL LED on relay board will be on whenever voltage is applied to 1SOL.

3. If machine is not filling, short the two FILL pins of J12 on the control board together to energize 1SOL.

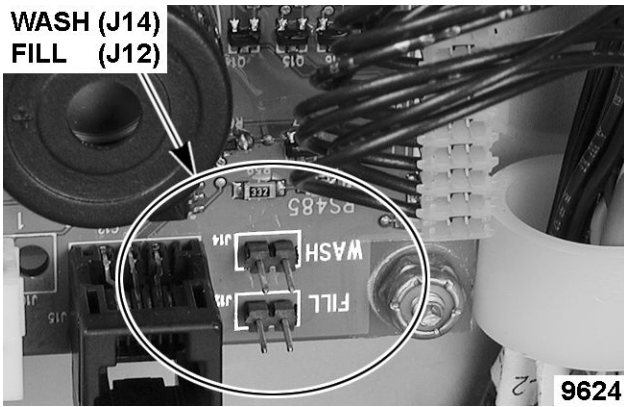

Fig. 24

- A. Verify the FILL LED on relay board is lit when J12 terminals on control board are shorted together.

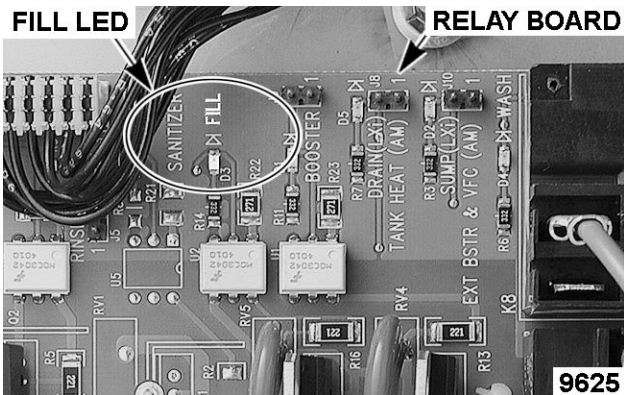

Fig. 25

- 1) If the solenoid does not energize, but the FILL LED on relay board is lit, check relay board J1-7 for 120VAC.
 - a. If 120VAC is not present across J1-7 and X2, the relay board has malfunctioned.
 - b. If 120VAC is present across J1-7 and X2, remove the short from J12 and check Fill/Rinse circuit.

NOTE: When 1SOL is energized, the voltage across J6-5 and ground will be zero or a few millivolts. Circuit activation can be verified by measuring 5VDC voltage across the control board +5VDC test pad and J6-5 when the FILL/RINSE circuit is active.

- 2) If 1SOL does not energize and the FILL LED does not light, check control board voltage output to relay board across J6-5 (control board) and ground = 0VDC (J6-5 and +5VDC test pad = 5VDC).

- a. If voltage measurements indicate circuit is active, verify wiring to relay board is correct. If correct, replace relay board.
 - b. If voltage measurements are not present, replace control board.
 - c. If voltage measurements remain constant at approximately 4.5VDC, check the door interlock circuit 1LS.
- 3) If the 1SOL energizes, remove J12 short and replace the control board.

Long Fill Time (6 minutes)

1. Verify the following.
 - A. OPERATING CONDITIONS are satisfied as stated at the beginning of this section.
 - B. Control board is programmed to operate as an SD3.
 - C. Chamber door is closed.
 - D. Flowing water pressure is correct (20psi ± 5psi).
 - E. Float switch circuit test good and is connected to wiring harness.
 - F. Drain is closed and not leaking.
2. If Low Water Level LED on control board is not lit when float switch is operated (closed), disconnect the thermistor and float connector from J2 on control board.

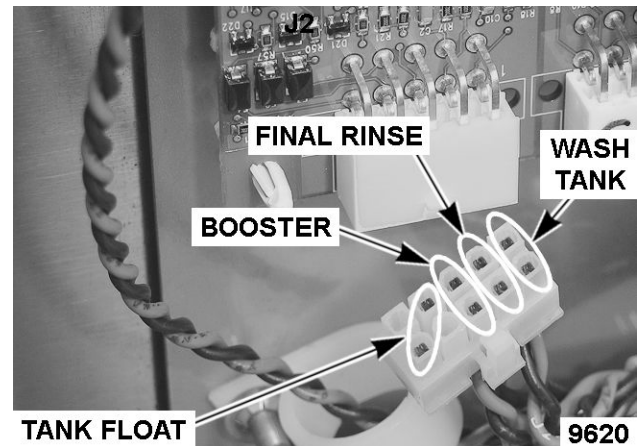

Fig. 26

- A. Check continuity of float switch. Cycle float (open and close) while observing meter.
- B. If continuity is not measured when float is operated, check float switch circuit.
- C. If continuity exists, float is working normally.

- 1) Verify no debris is present in tank that could cause float to malfunction.
- 2) If no debris is interfering with float operation, control board has malfunctioned.

No Wash Cycle

1. Verify the following.
 - A. OPERATING CONDITIONS are satisfied as stated at the beginning of this section.
 - B. Control board is programmed to operate as an SD3.
 - C. Dishwasher is full of water.

NOTE: The DOOR LED will be lit when the door switch 1LS is closed.

- D. Chamber door is closed.
- E. The MICRO LED is flashing at a rate of 1 sec on 1 sec off, and the DOOR and LOW WATER LEVEL LEDs on control board are on.
- F. Motor thermal circuit breaker is not tripped.

NOTE: The WASH LED on relay board will be on whenever voltage is applied to the pump motor.

2. Open and close chamber door. Wash cycle should begin. Check to see if the WASH LED on relay board is on.

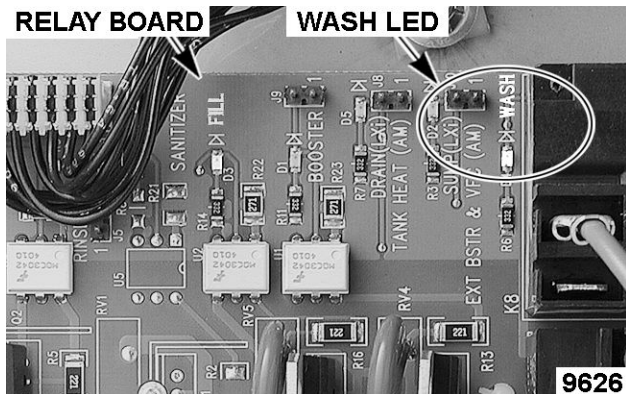

Fig. 27

- A. If the WASH LED is on, but the pump does not energize, check operation of K8 relay.
 - 1) If relay K8 functions normally, check remaining wash pump circuit.
- B. If WASH LED is not on, test pump motor circuit by shorting the two WASH pins of J14 on the control board together.

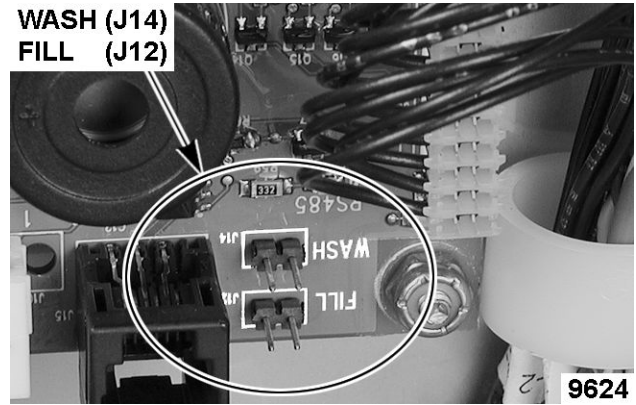

Fig. 28

- 1) If the wash pump energizes when pins J14 are shorted together, remove short then open and close dishwasher door. If wash cycle does not start, replace control board.

NOTE: When machine calls for wash (K8 energized), voltage across J6-6 and ground will be zero or a few millivolts. Circuit activation can be verified by measuring 5VDC voltage across the control board +5VDC test pad and J6-6 when the wash circuit is energized.

- 2) If WASH LED does not light and wash pump does not energize when J14 is shorted, check control board voltage output to relay board across J6-6 (control board) and ground = 0VDC (J6-6 and +5VDC test pad = 5VDC).
 - a. If voltage measurements indicate circuit is active, verify wiring to relay board is correct. If correct, replace relay board.
 - b. If voltage measurements are not present, replace control board.
 - c. If voltage measurements remain constant at approximately 4.5VDC, check the door interlock circuit 1LS.

No Tank Heat

1. Verify the following.
 - A. OPERATING CONDITIONS are satisfied as stated at the beginning of this section.
 - B. Control board is programmed to operate as an SD3.
 - C. Dishwasher is full of water and tank thermistor is good.
 - D. Tank temperature is programmed properly and machine is calling for heat.

- E. MICRO LED is flashing at a rate of 1 sec on, 1 sec off, and the DOOR and LOW WATER LEVEL LEDs on control board are on.

NOTICE Shorting J8 terminals together without having water in the tank may result in damaging the tank heater.

NOTE: The TANK HEAT (AM) LED on relay board should be lit when J8 terminals on relay board are shorted together.

- Test tank heat circuit by shorting the two terminals of J8 on the relay board together.

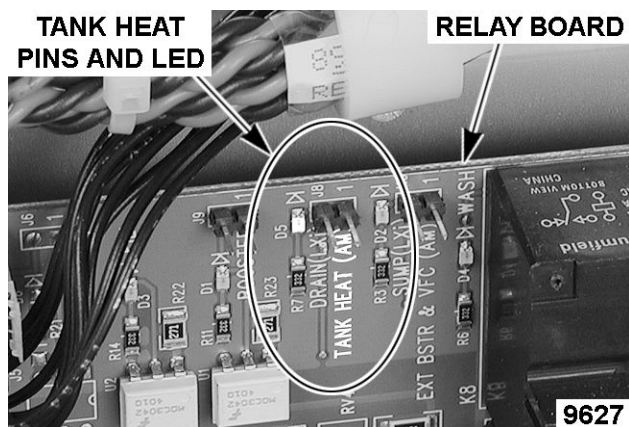

Fig. 29

NOTE: When machine calls for heat, voltage across J6-7 and ground will be zero or a few millivolts. Circuit activation can be verified by measuring 5VDC voltage across the control board +5VDC test pad and J6-7 when the TANK HEAT circuit is active.

- If heater circuit energizes, remove J8 short and troubleshoot the control board by checking voltage output to relay board across J6-7 (control board) and ground = 0VDC (J6-7 and +5VDC test pad = 5VDC).
 - If voltage measurements indicate circuit is active, verify wiring to relay board is correct. If correct, replace relay board.
 - If voltage measurements are not present, replace control board.
- If heater contactor 2CON does not energize, but TANK HEAT (AM) LED turns on, check for 120VAC across relay board J1-4 and X2.
 - If 120VAC is present, remove short across J8 and check remaining tank heat circuit.
 - If 120VAC is not present, replace relay board.

SERVICE DIAGNOSTICS

WARNING Certain procedures in this section require electrical test or measurements while power is applied to the machine. Exercise extreme caution at all times. If test points are not easily accessible, disconnect power and follow lockout / tagout procedures, attach test equipment and reapply power to the test.

NOTICE Certain components in this system are subject to damage by electrostatic discharge during field repairs. A field service grounding kit is available to prevent damage. The field service kit must be used anytime the control board is handled.

- Lower wash chamber door.
- Remove FRONT COVER.
- Open control door.
- Enter service diagnostics.
 - From power off. Press and hold both PROG and SELECT switches on the control board then press and release the ON key on the keypad. Continue to hold the PROG and SELECT switches until the display indicates [88]. Release the switches.
 - When machine is on and tank temperature displayed (FILL icon off). Press and hold PROG switch then press SELECT switch on control board.
- Perform tests as outlined under SERVICE DIAGNOSTICS CHART and OUTPUT TEST on the following pages.
- Exit service diagnostics by pressing the OFF key on keypad.

NOTE: When in service diagnostics mode the wrench icon will be displayed except during display test. When service diagnostics are entered, the control board will display the most recent P and E errors, if errors are present. A dash (-) in place of a number in either the left or right digit position indicates no error to be displayed for that digit. Example: If [- 2] were displayed, the only fault recorded was, "Water not to float." However, if [2 2] were displayed, "Rinse thermistor error" and "Water not to float" have both occurred.

ERROR CODES (IN SERVICE DIAGNOSTICS SCREEN)		
Left Digit (1)	Right Digit (1)	Description of Error
-	-	Normal operation. No recorded errors.
-	d	Slow Leak.
-	E	Booster set point timeout (480 sec. after initial fill).
-	F	Control board E-prom error.
-	2	Water not to float on initial fill.
-	6	Float or temperature thermistor(s) open or connector J1 on control board is open.
1	-	Wash thermistor error.
2	-	Rinse thermistor error.
3	-	Booster thermistor error.

SERVICE DIAGNOSTICS CHART

TEST	ACTIVE KEY	KEY RESPONSE	DISPLAY DATA
Recorded Error	▲ (arrow)	Reset recorded error(s)	Error messages (see ERROR CODES table). NOTE: Only the most recent error recorded for each digit (left/right) are stored and displayed. Previously recorded errors are overwritten.
	Select	Jump to display test.	
Display Test	▲ (arrow)	Step through display test.	Sequences LED segments on display board for test.
	Select	Jump to Keypad Test.	
CYCLE, ▲ and PROG Switch Test	—	Pressing any of the switches under test displays a corresponding number for that switch.	Display key number: CYCLE (keypad) = 1 ▲ (control board) = 2 PROG (control board) = 3
	Select	Jump to Revision Level display.	
Software Revision Level Display	▲ (arrow)	No change	Display Revision Level of Software.
	Select	Jump to Wash Temp	
Tank Temperature	Select	Jump to Rinse Temp	Tank temp and WASH icon. Thermistor errors are indicated as 'oP' or 'SP' for open or shorted thermistors respectively.
Rinse Temperature	Select	Jump to Booster Temp	Rinse temp and RINSE icon. Thermistor errors are indicated as 'oP' or 'SP' for open or shorted thermistors respectively.
Booster Temperature (AH only)	Select	Jump to Cycle Counter Display	Booster temp and WASH/RINSE icons. Thermistor errors are indicated as 'oP' or 'SP' for open or shorted thermistors respectively.

TEST	ACTIVE KEY	KEY RESPONSE	DISPLAY DATA
Cycle Counter	▲ (arrow)	Step through icons	See example of cycle count below table. M = million ADD icon = 00 - 99 x 1M DETERGENT icon = 00 - 99 x 1M SANITIZER icon = 00 - 99 x 10,000 RINSE icon = 00 - 99 x 100 AID icon = 00 - 99 x 1 NOTE: If no display seen for an icon, total machine cycles is below that multiplier.
	Select	Jump to Delime Cycles	
Delime Cycle Counter (Cycles since last delime operation)	▲ (arrow)	Step through icons	DELIME - icon on Always set to 0 for SD3
	Select	Jump to Output Tests	
Output Test	▲ (arrow)	Next Output	See OUTPUT TEST on following page
	Select	Jump to Firmware Rev.	
Reset Mode	Select	Jump to Recorded Error	Microcontroller code for Engineering use.

EXAMPLE: Retrieved data is; ADD = (no display), DETERGENT = 2, SANITIZER = 07, RINSE = 30, AID = 76

- | | |
|---|---|
| 1. Disregard ADD since there is no numeric display. | 5. Multiply 76 x 1 (AID) = 76 |
| 2. Multiply 2 x 1,000,000 (DETERGENT) = 2,000,000 | 6. Add products together to obtain total cycle count. |
| 3. Multiply 07 x 10,000 (SANITIZER) = 70,000 | Total Cycles = 2,000,000 + 70,000 + 3000 + 76 |
| 4. Multiplier 30 x 100 (RINSE) = 3000 | Total Cycles = 2,073,076 |

OUTPUT TESTS

⚠ WARNING CLOSE DOOR BEFORE BEGINNING OUTPUT TEST. KEEP DOOR CLOSED DURING TEST.

The output test cycles the relay outputs ON and OFF. The output is ON for 5 seconds, then OFF for 25 seconds. The display alternates between flashing the output number chosen and [On] for five seconds when the output is energized. When the output is de-energized, the display will alternate between the output number chosen and the remaining off time (count down) in seconds. The output test continues for the same output number until ^a (arrow) or SELECT is chosen.

SEQUENCE OF OUTPUTS	
Relay Description	Output No.
EXT BSTR VFC	0
Booster Heat (3CON)	1
Fill/Rinse (1SOL)	2
Tank Heat (2CON)	3
Wash Pump (1CON)	4
Sanitizer Pump (1)	5
Detergent Pump (1)	6
Rinse Aid Pump (1CR)	7

(1) Disregard sanitizer and detergent output tests. These features are not utilized on SD3 machines. Replacement relay boards will have components mounted on the board for the sanitizer and detergent circuits, but will not be used by SD3 dishwashers.

NOTE: When troubleshooting, always check for correct voltage, current, and resistance as specified by the machine's data plate. Before troubleshooting machine, verify that the control board assembly is programmed to operate as an SD3.

VERIFY CONTROL BOARD is CONFIGURED as an SD3

1. Turn dishwasher off.
2. Press the ON key on the switch membrane keypad.
 - A. Control board/display will begin a self-check. When self-check completes, machine type will be displayed briefly.

- 1) AP (plain - external booster).
- 2) AH (hot - self-contained booster).
3. If machine type programmed into control board is other than machine type on data plate, the control board must be programmed before continuing. Refer to CONTROL BOARD PROGRAMMING as outlined in SERVICE PROCEDURES AND ADJUSTMENTS.
4. Check machine operation to see if problem still exists.

ERROR CODE CHART

ERROR CODE CHART		
Error Code	Explanation	Troubleshooting
E3 E1 - After wash cycle. NOTE: Shows Pd while washing	1:15 cycle no rinse - E1	
E2	Water did not reach the float during a fill within 150 seconds.	Ensure drain lever is closed and the standpipe is properly seated. Verify float is clear of debris. Ensure the incoming water valve is open and water flow/pressure is 20psi (+/- 5psi).
E6	Float and temperature thermistors could not be detected.	Verify operation of float and temperature thermistors. Ensure thermistor and door switch plug is connected to J2 on control board.
Ed	Slow Leak. Machine enters fill cycle three times with 35 minutes of initial fill.	Ensure drain lever is closed and the standpipe is properly seated with the O-ring clear of food soils or other debris.
EE	Booster did not reach temperature within eight minutes after initial fill.	Check to see that booster power is on. Check that the water heater is on and supplying proper hot water (min of 110°F).
EF	Severe internal control error.	Control board malfunction.
P1	Open or shorted wash tank thermistor.	Check thermistor and switch thermistor and wiring.
P2	Open or shorted rinse thermistor.	Check rinse thermistor and wiring.
P3	Open or shorted booster thermistor.	Check booster thermistor and wiring.

TROUBLESHOOTING TABLE

NOTE: Before troubleshooting machine, verify that control board assembly is programmed to operate as

an SD3. Refer to CHECKING CONTROL BOARD CONFIGURATION as outlined in this section.

SYMPTOM	POSSIBLE CAUSES
No display	<ol style="list-style-type: none"> 1. No power to machine. Fuse blown or circuit breaker tripped. 2. Fuse F2 on relay board open. 3. Missing 120VAC from 1T. 4. Missing 11.5-16VAC from 2T to control board J1 1&3. 5. Display board unplugged from control board or display board malfunction. 6. Control board malfunction.
Machine will not fill. No error code displayed.	<ol style="list-style-type: none"> 1. Door is not shut. 2. Water not turned on. 3. Door interlock malfunction. 4. Door magnet missing
Machine will not wash. Tank is filled with water. (Door must be opened and closed to start wash cycle.)	<ol style="list-style-type: none"> 1. Door switch malfunction. Verify DOOR LED on control board is on when chamber door is closed. 2. Tank float malfunction. Verify LOW LEVEL WATER LED on control board is on. 3. Obstruction in pump. 4. Motor overload tripped. 5. Motor malfunction
Booster heater does not heat at all.	<ol style="list-style-type: none"> 1. No water in dishwasher tank or float circuit malfunction 2. No power to booster. 3. Fuse blown in booster circuit or circuit breaker tripped. 4. Contactor malfunction (3CON). 5. Transformer malfunction 120VAC (1T). 6. High limit thermostat(s) malfunction 7. Thermistor malfunction 8. Heater element malfunction 9. Control board assembly malfunction
Rinse water temperature does not reach 180°F.	<ol style="list-style-type: none"> 1. Heating element malfunction 2. Incoming water temperature too low (minimum is 110°F). 3. Voltage to booster heating circuit not correct. 4. Incorrect heater being used. 5. Booster heating elements coated with lime
Booster heater repeatedly blows fuse or trips circuit breakers	<ol style="list-style-type: none"> 1. Undersized fuse. 2. Check wire and fuse size. 3. Short circuit in internal wiring 4. Incorrect voltage or heater
Booster heating element burns out repeatedly	<ol style="list-style-type: none"> 1. Element powered with low or no water in booster. 2. Check for correct heater and voltage. Verify with machine data plate. 3. Contactor malfunction (3CON).

SYMPTOM	POSSIBLE CAUSES
Rinse aid pump not energizing.	<ol style="list-style-type: none">1. Fuse F1 on relay board open.2. Relay 1CR malfunction.3. External wiring to rinse device issue.4. Rinse aid pump (supplied by others) malfunction5. Relay board malfunction6. Control board malfunction
Booster high limit thermostat trips.	<ol style="list-style-type: none">1. High limit thermostat switch malfunction2. Booster temperature setting on control board too high.3. Contactor malfunctioning (3CON).4. No water in booster tank
Display indicates cycle is in process, but machine is idle (tank is filled with water).	<ol style="list-style-type: none">1. Control board/relay board connections.2. Relay board malfunction.3. Control board malfunction



CATALOG OF REPLACEMENT PARTS



SD3 DISHWASHER

ML-130232 SD3

Table of Contents

5	CONTROLS
7	CONTROL CABLES
9	CONTROL BOX
11	MOTOR AND PUMP
13	UPPER WASH ARM
15	LOWER WASH ARM
17	RINSE PIPING (WITHOUT BOOSTER)
19	RINSE PIPING (WITH BOOSTER)
21	BOOSTER PIPING
23	ELECTRIC BOOSTER TANK
25	LOW WATER PROTECTION AND ELECTRIC HEAT
27	DRAIN UNIT
29	DRAIN WATER TEMPERING (OPTIONAL ACCESSORY)
31	DOOR ASSEMBLY
33	PANELS AND RACK SUPPORT

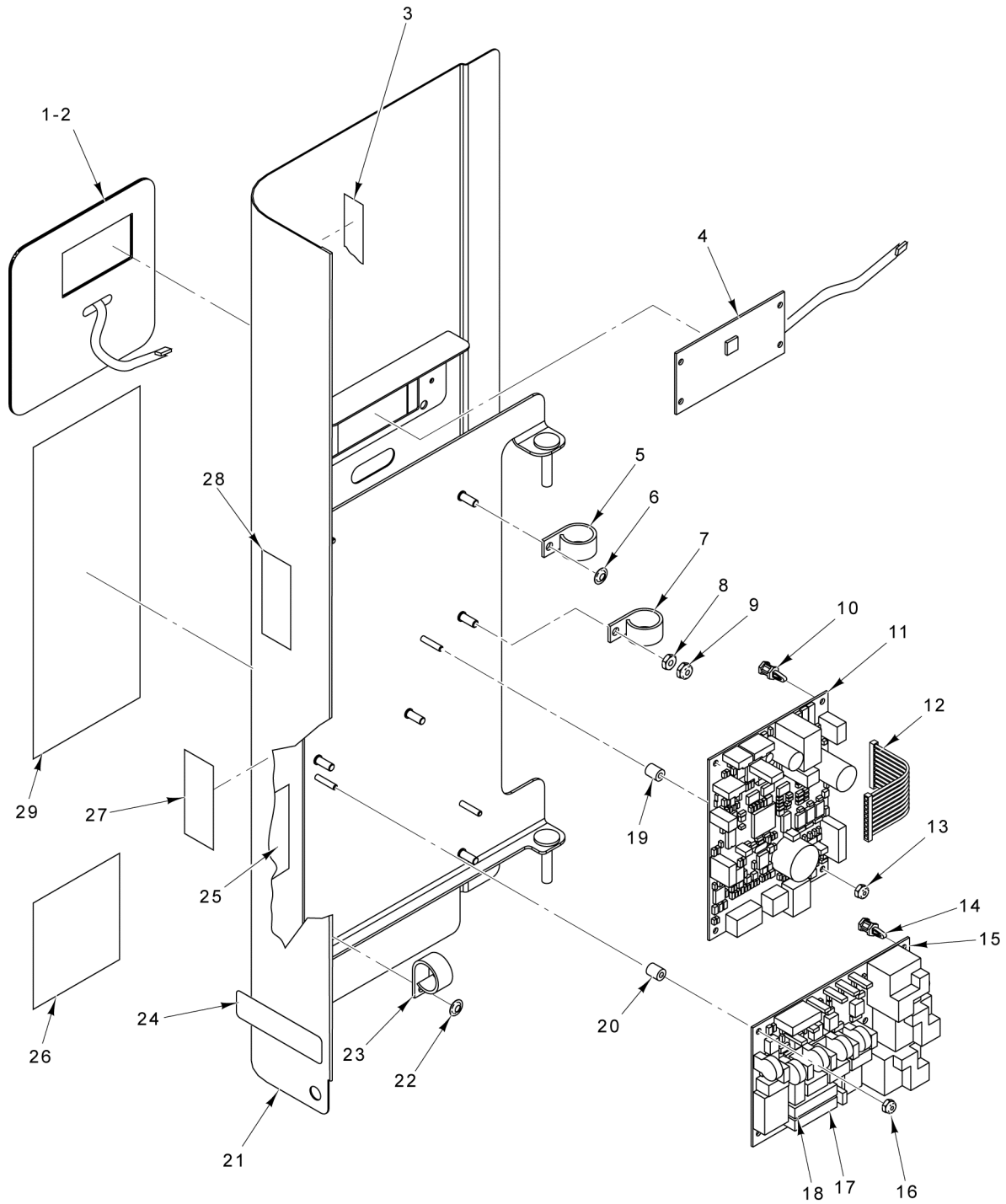

PL-60512

CONTROLS

CONTROLS

ILLUS.	PART NO.	NAME OF PART	AMT.
PL-60512			
1	0P-428299	Switch - Membrane Keypad.....	1
2	0P-428301	Trim - Keypad.....	1
3	0P-578212	Foam Tape.....	AR
4	0P-428217	Display Module.....	1
5	0A-108045	Clamp - Wire (3/4 I.D.).....	1
6	0P-678336	Lock Nut 3/16 Washer Type (SST).....	1
7	0A-108045	Clamp - Wire (3/4 I.D.).....	1
8	0P-678137	Nut 10-24 Hex (SST).....	1
9	0P-678335	Stop Nut 10-24 Hex Elastic (SST).....	1
10	0P-428218	Standoff.....	2
11	0P-428306	Control Board Assy.....	1
12	0P-458219	Ribbon Cable Assy.....	1
13	0P-678141	Stop Nut 6-32 Hex (SST).....	2
14	0P-428218	Standoff.....	2
15	0P-428220	Board - Relay Assy.....	1
16	0P-678141	Stop Nut 6-32 Hex (SST).....	2
17	0P-528313	Fuse (250 V.) (1 Amp.).....	1
18	0P-528315	Fuse (250 V., 0.1 Amp.).....	1
19	0P-428185	Standoff - Reed Board (3/8) (Control Board).....	2
20	0P-428185	Standoff - Reed Board (3/8) (Relay Board).....	2
21	0P-428300	Corner - Display.....	1
22	0P-678336	Lock Nut 3/16 Washer Type (SST).....	4
23	0A-108045	Clamp - Wire (3/4 I.D.).....	4
24	0P-698261	Plate (Patent Numbers).....	1
25	0A-698310	Label - Warning (Fuse) (Electric Heat) Label - Warning.....	1
26	0A-698303	Plate - Machine Data.....	1
27	0P-698207	Label - Warning (Electric Heat W/Booster) Label - Warning.....	1
28	0A-698311	Label (Error Code).....	1
29	0P-698208	Label - Instruction.....	1

Item Number	Description
1	Ribbon Cable Assy
2	Harness - Sensor Assy.
3	Harness - Relay Board Assy.
4	Cable - Rinse Thermistor
5	Cable - Rinse Valve (WO/Electric Booster) (Incls. DIN Connector)
6	Cable - Rinse Valve (W/Electric Booster) (Incls. DIN Connector)

PL-60513

CONTROL CABLES

CONTROL CABLES

ILLUS.	PART NO.	NAME OF PART	AMT.
1	0P-458219	Ribbon Cable Assy.....	1
2	0P-458259	Harness - Sensor Assy.....	1
3	0P-458260	Harness - Relay Board Assy.....	1
4	0P-458254	Cable - Rinse Thermistor.....	1
5	0P-458255	Cable - Rinse Valve (WO/Electric Booster) (Incls. DIN Connector).....	1
6	0P-458256	Cable - Rinse Valve (W/Electric Booster) (Incls. DIN Connector).....	1

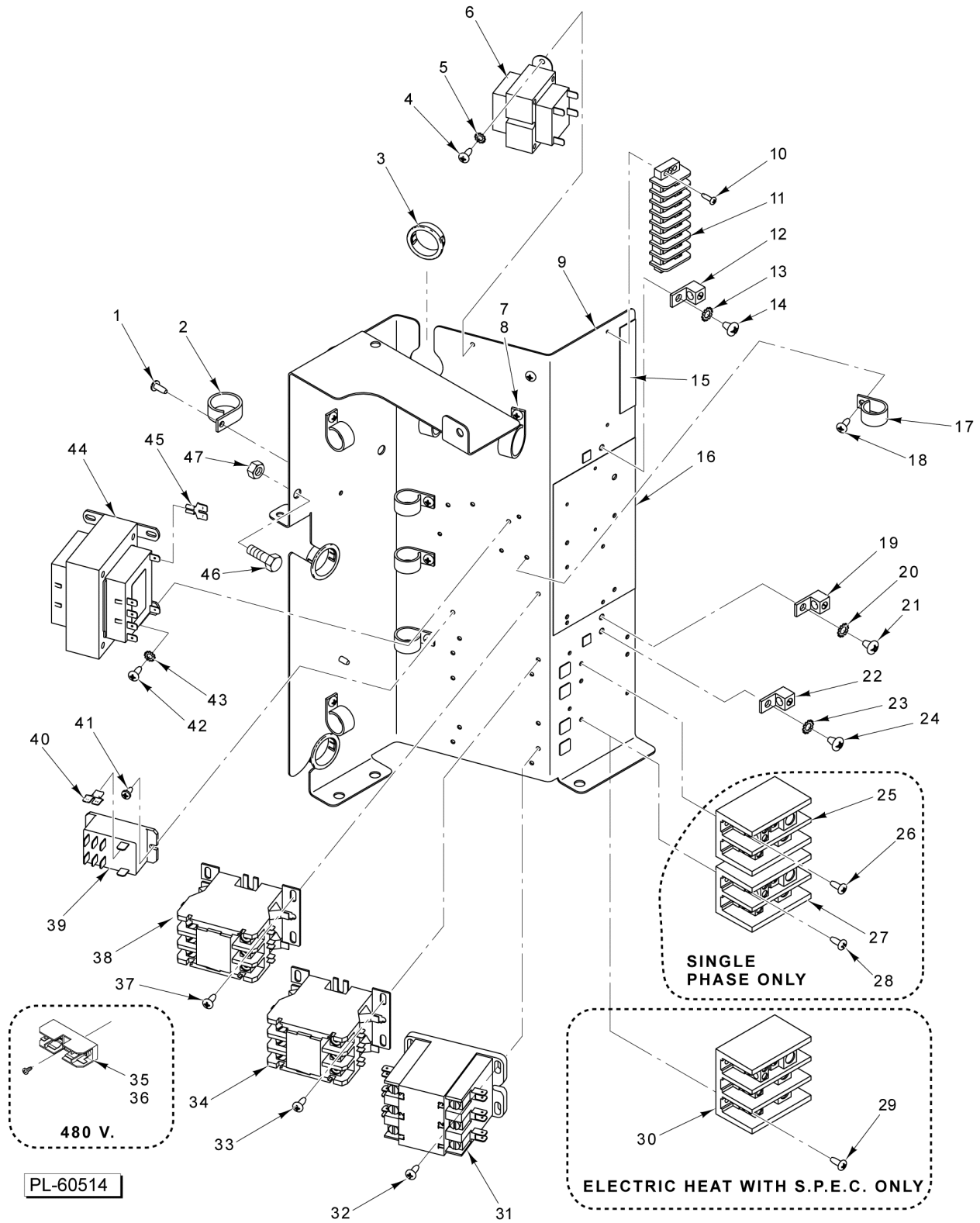

PL-60514

CONTROL BOX

CONTROL BOX

ILLUS.	PART NO.	NAME OF PART	AMT.
	PL-60514		
1	0P-678161	Self-Tapping Screw 10-16 x 1/2 Phil. Pan Hd., Type B.....	3
2	0A-108203	Clamp - Wire (1 I.D.).....	3
3	0P-668314	Bushing - Electrical Snap.....	3
4	0P-678161	Self-Tapping Screw 10-16 x 1/2 Phil. Pan Hd., Type B.....	2
5	0P-678352	Lockwasher #10 External Shakeproof (SST).....	2
6	0P-538200	Transformer (T2) (30 VA, 50/60 Hz.).....	1
7	0P-678161	Self-Tapping Screw 10-16 x 1/2 Phil. Pan Hd., Type B.....	2
8	0A-108203	Clamp - Wire (1 I.D.).....	2
9	0A-108262	Box - Control.....	1
10	0P-678347	Self-Tapping Screw 6-20 x 1/2 Phil. Pan Hd., Type B.....	2
11	0P-528240	Block - Terminal (Double Row).....	1
12	0P-528186	Lug - Grounding.....	1
13	0P-678351	Lockwasher 1/4 External Shakeproof.....	1
14	0P-678348	Self-Tapping Screw 1/4-20 x 3/8 Phil. Pan Hd., Type TT.....	1
15	0A-698309	Label - Terminal Block.....	1
16	0A-698312	Label - Electric Ampacity.....	1
17	0A-108045	Clamp - Wire (3/4 I.D.).....	6
18	0P-678161	Self-Tapping Screw 10-16 x 1/2 Phil. Pan Hd., Type B.....	6
19	0P-528186	Lug - Grounding (Electric Booster).....	1
20	0P-678351	Lockwasher 1/4 External Shakeproof (Electric Booster).....	1
21	0P-678348	Self-Tapping Screw 1/4-20 x 3/8 Phil. Pan Hd., Type TT (Electric Booster).....	1
22	0P-528186	Lug - Grounding.....	1
23	0P-678351	Lockwasher 1/4 External Shakeproof.....	1
24	0P-678348	Self-Tapping Screw 1/4-20 x 3/8 Phil. Pan Hd., Type TT.....	1
25	0P-528198	Block - Terminal (Electric Booster) (1 Ph.).....	1
26	0P-678161	Self-Tapping Screw 10-16 x 1/2 Phil. Pan Hd., Type B (1 Ph.).....	2
27	0P-528198	Block - Terminal (Electric Booster) (1 Ph.).....	1
28	0P-678161	Self-Tapping Screw 10-16 x 1/2 Phil. Pan Hd., Type B.....	2
29	0P-678161	Self-Tapping Screw 10-16 x 1/2 Phil. Pan Hd., Type B.....	4
30	0P-528188	Block - Terminal.....	1
31	0P-478267	Contactactor (40 Amp., 3-Pole).....	1
32	0P-678161	Self-Tapping Screw 10-16 x 1/2 Phil. Pan Hd., Type B.....	2
33	0P-678161	Self-Tapping Screw 10-16 x 1/2 Phil. Pan Hd., Type B.....	2
34	0P-478181	Contactactor (25 Amp., 3-Pole).....	1
35	0P-528199	Block - Fuse (Gas Heat).....	1
36	0P-688133	Fuse (5.0 Amp., 250 V.).....	1
37	0P-678161	Self-Tapping Screw 10-16 x 1/2 Phil. Pan Hd., Type B.....	2
38	0P-478181	Contactactor (25 Amp., 3-Pole).....	1
39	0P-478182	Relay (2-Pole) (30 Amp.).....	1
40	0P-688134	Adapter - Electrical.....	1
41	0P-678160	Self-Tapping Screw 8-18 x 3/8 Phil. Bndg. Hd., Type B.....	2
42	0P-678161	Self-Tapping Screw 10-16 x 1/2 Phil. Pan Hd., Type B.....	4
43	0P-678352	Lockwasher #10 External Shakeproof (SST).....	4
44	0P-538201	Transformer (100 VA.) (50/60 Hz.) Transformer (T1) (208/240/480 V., 50/60 Hz.).....	1
45	0P-688134	Adapter - Electrical.....	1
46	0P-678341	Cap Screw 5/16-18 x 1-1/8 Hex Hd. (SST).....	4
47	0P-678142	Stop Nut 5/16-18 Hex (SST).....	4

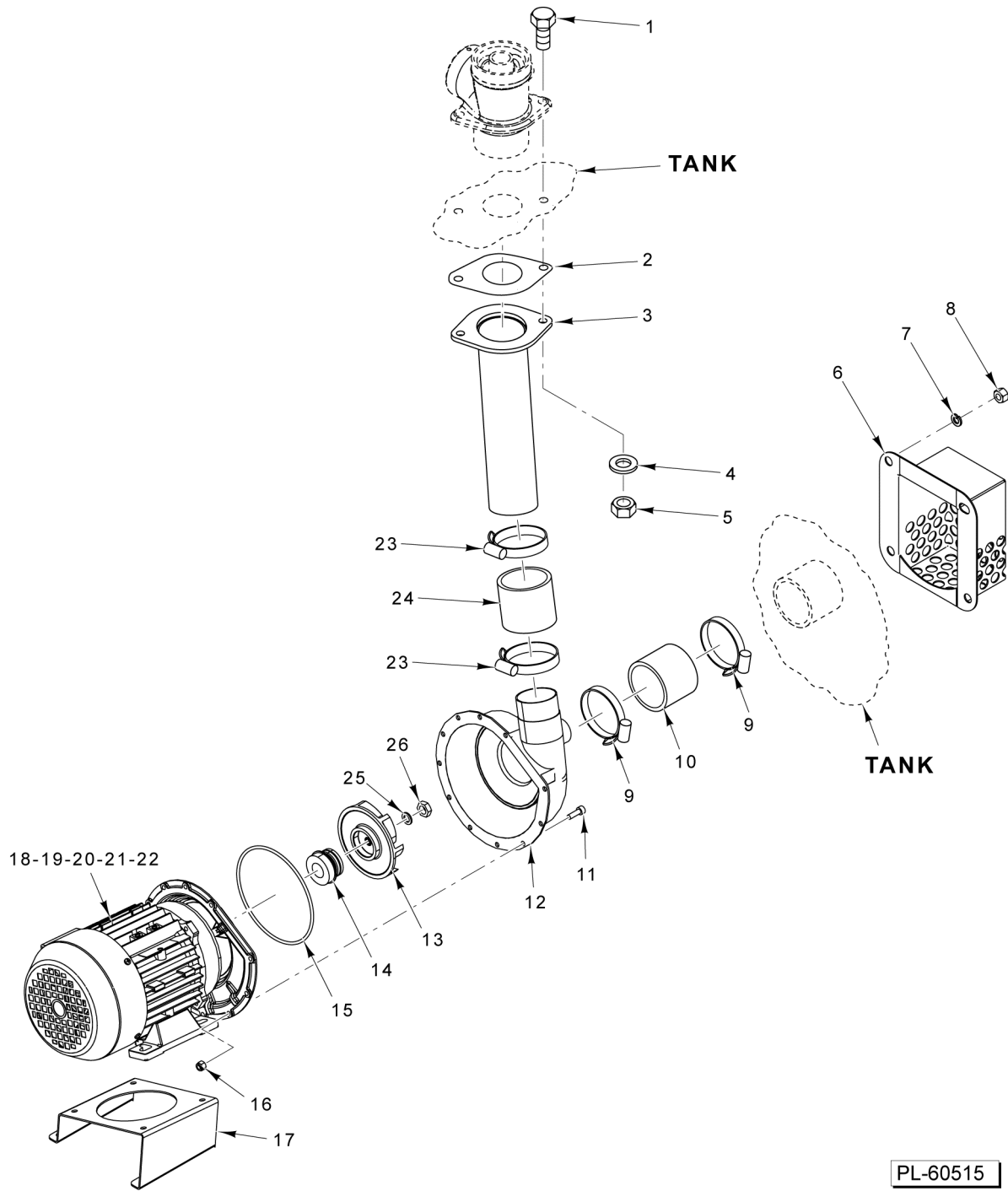

MOTOR AND PUMP

PL-60515

MOTOR AND PUMP

ILLUS.	PART NO.	NAME OF PART	AMT.
PL-60515			
1	0P-678341	Cap Screw 5/16-18 x 1-1/8 Hex Hd. (SST).....	2
2	0P-578248	Gasket - Adapter.....	1
3	0A-108285	Adapter (Pump-to-Manifold).....	1
4	0P-678169	Washer (SST).....	2
5	0P-678142	Stop Nut 5/16-18 Hex (SST).....	2
6	0A-108239	Screen - Pump.....	1
7	0P-678165	Lockwasher 5/16 Helical (SST).....	4
8	0P-678139	Nut 5/16-18 Hex (SST).....	4
9	0A-108211	Clamp - Hose.....	2
10	0P-688297	Hose - Pump Intake.....	1
11	0P-678294	Mach. Screw 6mm x 18mm (SST).....	11
12	0B-108293	Pump Shell (Outer).....	1
13	0B-108289	Impeller (60 Hz.).....	1
14	0P-578288	Shaft - Seal.....	1
15	0P-578292	Seal.....	1
16	0P-678295	Lock Nut 6mm (SST).....	11
17	0A-108279	Bracket - Motor Mounting.....	1
18	0P-418286	Motor (208-240/480/60/3).....	1
19	0P-418287	Motor (208-240/60/1).....	1
20	0P-418296	Fan - Cooling 60 Hz.....	1
21	0C-418283	Pump & Motor Assembly 208-240/480/60/3.....	1
22	0C-418284	Pump & Motor Assembly 208-240/60/1.....	1
23	0A-108213	Clamp - Hose.....	2
24	0P-688225	Hose - Discharge.....	1
25	0P-678290	Lockwasher 10mm (SST).....	1
26	0P-678291	Jam Nut 10mm (SST).....	1

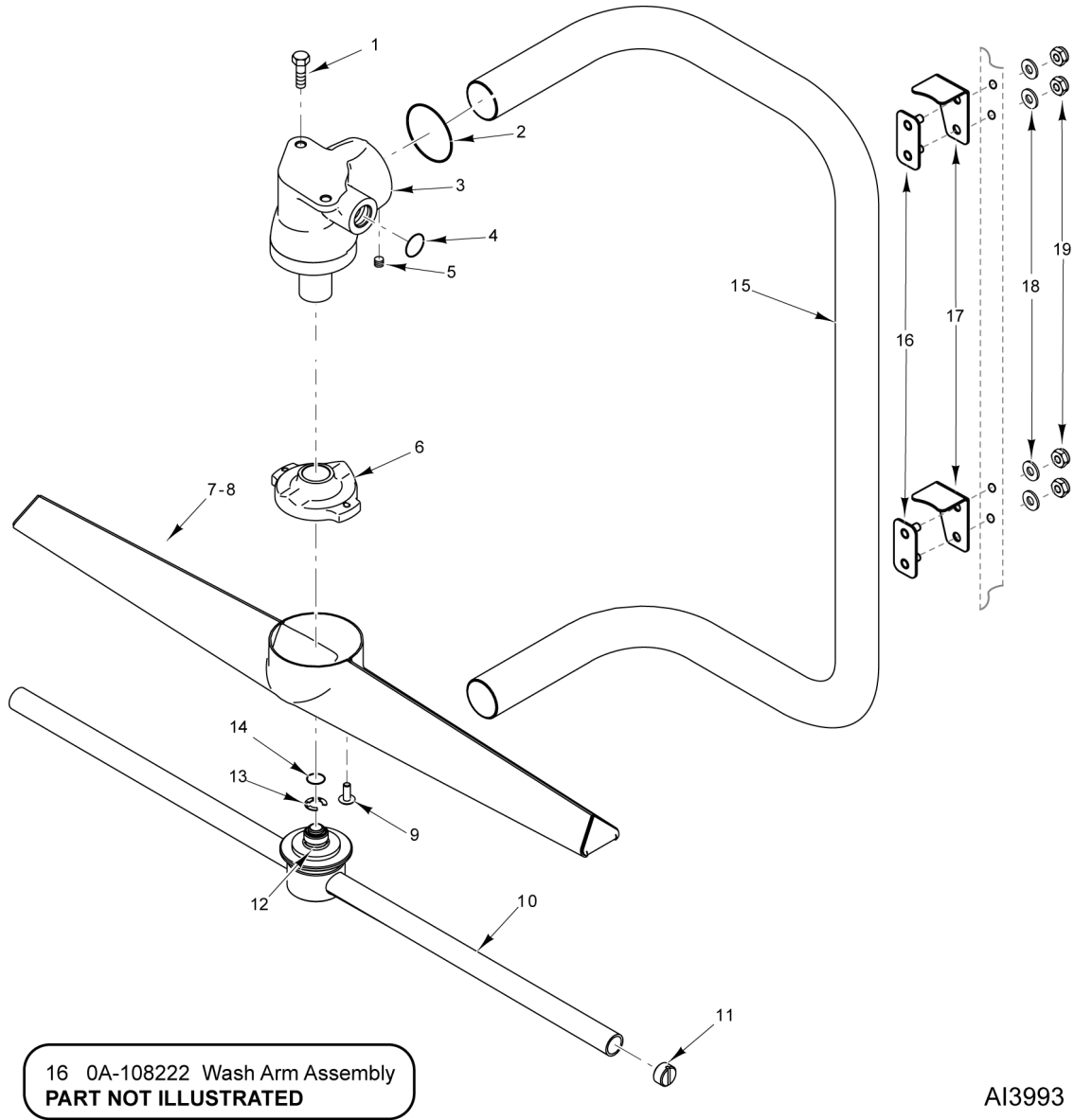

UPPER WASH ARM

UPPER WASH ARM

ILLUS.	PART NO.	NAME OF PART	AMT.
PL-AI3993			
1	0P-678346	Cap Screw 5/16-18 x 3/8 Hex Hd.....	2
2	0P-578176	O-Ring.....	1
3	0B-108308	Wash Manifold Assy. (Upper).....	1
4	0P-578179	O-Ring.....	1
5	0P-678343	Set Screw 10-24 x 1/4 Hex Hdls., Cup Pt. (SST).....	2
6	0B-108298	Hub - Wash Arm.....	1
7	0A-108221	Arm - Wash.....	1
8	0A-108222	Wash Arm Assy. Wash Arm Assy. (Incls. Items 8, 9, & 11).....	1
9	0P-678344	Mach. Screw 10-24 x 1/2 Phil. Truss Hd. (SST).....	2
10	0A-108245	Arm - Rinse (Incls. Items 13 & 14).....	1
11	0A-108246	Plug - Rinse Arm.....	2
12	0P-668243	Bearing.....	1
13	0P-678338	Retaining Ring.....	1
14	0P-578178	O-Ring.....	1
15	0A-108227	Tube - Wash.....	1
16	0A-108581	Assy, Mount, Door Stop.....	2
17	0A-108580	Bracket & Retainer for wash tube.....	2
18	P678170	Washer (SST).....	4
19	NS-047-82	Stop Nut 1/4-20 Hex (SST).....	4

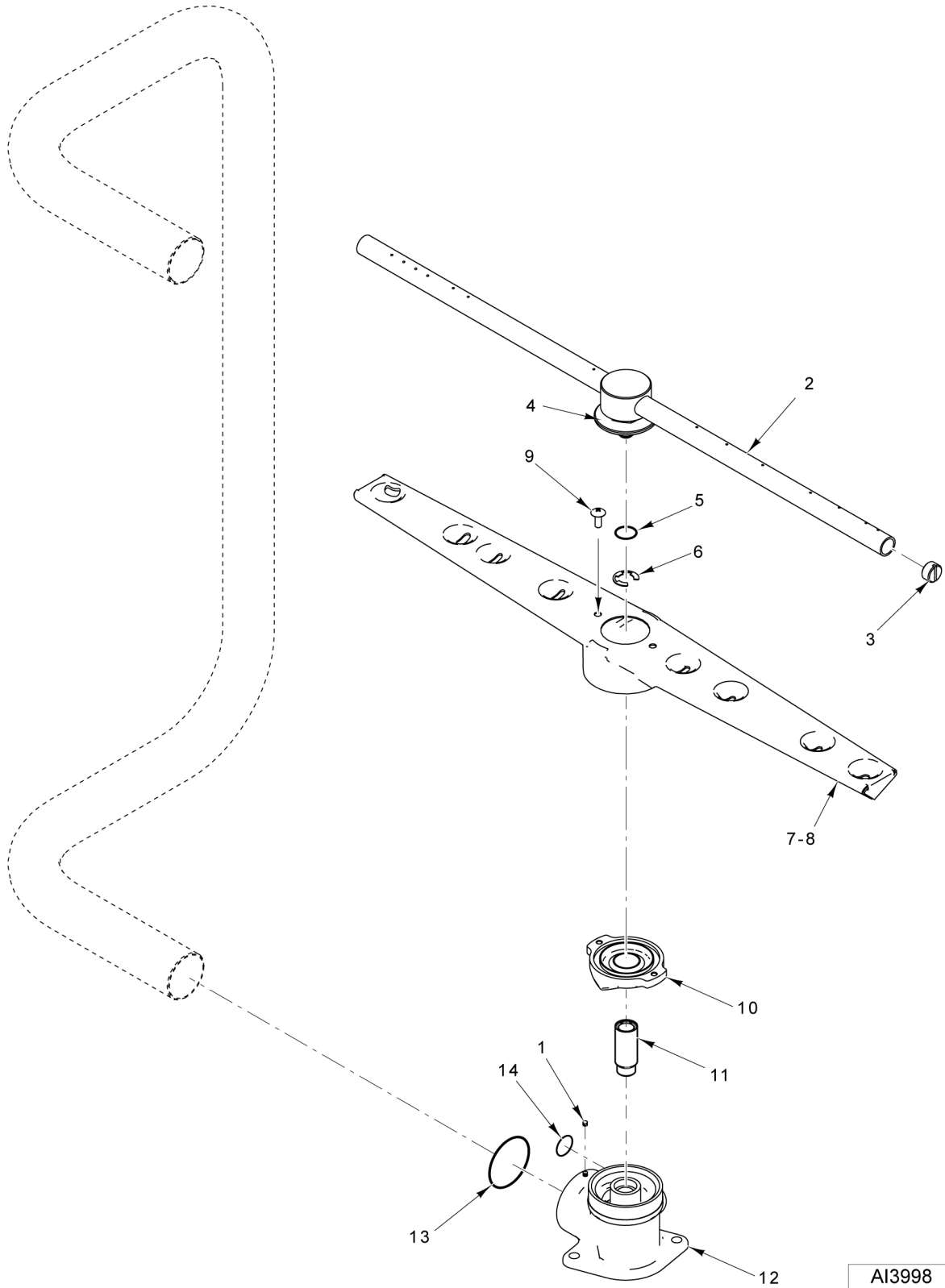

AI3998

LOWER WASH ARM

LOWER WASH ARM

ILLUS.	PART NO.	NAME OF PART	AMT.
	PL-AI3998		
1	0P-678343	Set Screw 10-24 x 1/4 Hex Hdls., Cup Pt. (SST).....	2
2	0A-108245	Arm - Rinse (Incls. Items 3 & 4).....	1
3	0A-108246	Plug - Rinse Arm.....	2
4	0P-668243	Bearing.....	1
5	0P-578178	O-Ring.....	1
6	0P-678338	Retaining Ring.....	1
7	0A-108222	Wash Arm Assy. Wash Arm Assy. (Incls. Items 8, 9, & 10).....	1
8	0A-108221	Arm - Wash.....	1
9	0P-678344	Mach. Screw 10-24 x 1/2 Phil. Truss Hd. (SST).....	2
10	0B-108298	Hub - Wash Arm.....	1
11	0A-108234	Shaft - Rinse Arm Shaft - Rinse Arm.....	1
12	0B-108226	Manifold - Wash (Lower).....	1
13	0P-578176	O-Ring.....	1
14	0P-578179	O-Ring.....	1

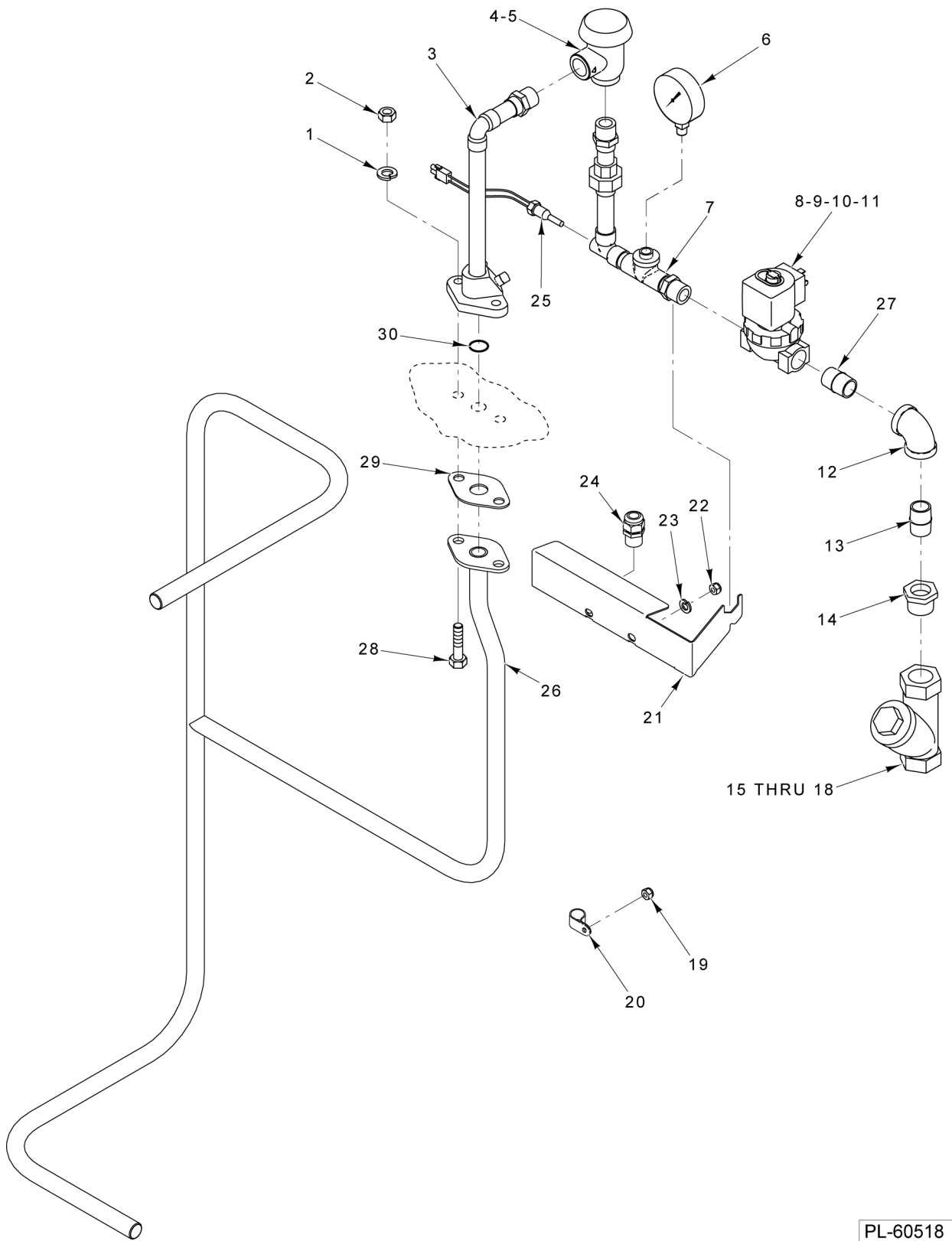

PL-60518

**RINSE PIPING
(WITHOUT BOOSTER)**

**RINSE PIPING
(WITHOUT BOOSTER)**

ILLUS.	PART NO.	NAME OF PART	AMT.
PL-60518			
1	0P-678165	Lockwasher 5/16 Helical (SST).....	2
2	0P-678142	Stop Nut 5/16-18 Hex (SST).....	2
3	0B-108236	Piping - Fill.....	1
4	0P-628041	Vacuum Breaker (1/2 In.).....	1
5	00-292910	Service Kit - Vacuum Breaker.....	1
6	0P-658268	Gauge - Water Pressure Gauge - Water Pressure.....	1
7	0B-108237	Fill Piping Assy.....	1
8	0P-548093	Solenoid Valve (1/2) (120 V.).....	1
9	0P-548085	Coil - Solenoid Valve (120 V.).....	1
10	0P-548094	Service Kit - 1/2 Solenoid Valve.....	1
11	0P-458210	Connector - D.I.N.....	1
12	0P-688317	Elbow - Pipe 1/2 x 90 Deg. (Brass).....	1
14	0P-688320	Bushing - Pipe 3/4 to 1/2 (Brass).....	1
13	0P-688326	Pipe 1/2 x 2 TBE (Brass).....	1
15	0P-638036	Strainer - Line (3/4 In.) (Brass) (Incls. Items 16, 17, & 18).....	1
16	0P-688037	Plug - Branch.....	1
17	0P-688039	Screen - Line Strainer.....	1
18	0P-578038	0P-578038.....	1
19	0P-678336	Lock Nut 3/16 Washer Type (SST).....	1
20	0A-108203	Clamp - Wire (1 I.D.).....	1
21	0A-108235	Bracket - Fill Piping.....	1
22	0P-678139	Nut 5/16-18 Hex (SST).....	2
23	0P-678165	Lockwasher 5/16 Helical (SST).....	2
24	0P-528129	Connector - Strain Relief.....	2
25	0P-658206	Probe Assy. - Rinse.....	1
26	0A-108228	Inside Rinse Piping Assy. Inside Rinse Piping Assy.....	1
27	0P-688324	Pipe 1/2 x 1-3/8 TBE (Brass).....	1
28	0P-678150	0P-678150.....	2
29	0P-578196	Gasket - Rinse Pipe.....	1
30	0P-578172	O-Ring.....	1

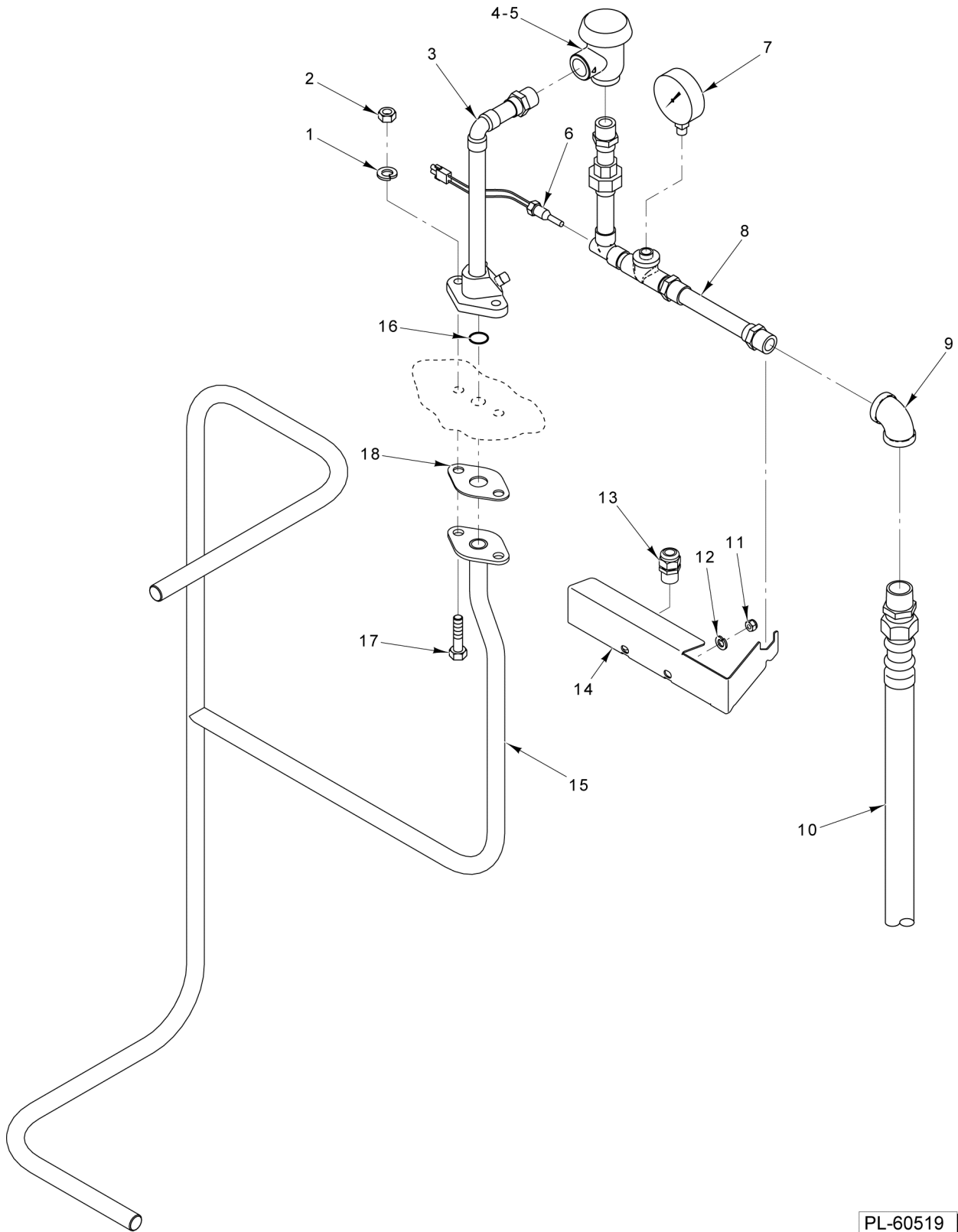

PL-60519

**RINSE PIPING
(WITH BOOSTER)**

**RINSE PIPING
(WITH BOOSTER)**

ILLUS.	PART NO.	NAME OF PART	AMT.
PL-60519			
1	0P-678165	Lockwasher 5/16 Helical (SST).....	2
2	0P-678142	Stop Nut 5/16-18 Hex (SST).....	2
3	0B-108236	Piping - Fill.....	1
4	0P-628041	Vacuum Breaker (1/2 In.).....	1
5	0P-628042	Repair Kit - Vacuum Breaker.....	1
6	0P-658206	Probe Assy. - Rinse.....	1
7	0P-658268	Gauge - Water Pressure Gauge - Water Pressure.....	1
8	0B-108238	Fill Piping Assy.....	1
9	0P-688317	Elbow - Pipe 1/2 x 90 Deg. (Brass).....	1
10	0P-688258	Hose - Water (Braided) (84 In.) (SST).....	1
11	0P-678139	Nut 5/16-18 Hex (SST).....	2
12	0P-678165	Lockwasher 5/16 Helical (SST).....	2
13	0P-528129	Connector - Strain Relief.....	1
14	0A-108235	Bracket - Fill Piping.....	1
15	0A-108228	Inside Rinse Piping Assy. Inside Rinse Piping Assy.....	1
16	0P-578172	O-Ring.....	1
17	0P-678150	0P-678150.....	2
18	0P-578196	Gasket - Rinse Pipe.....	1

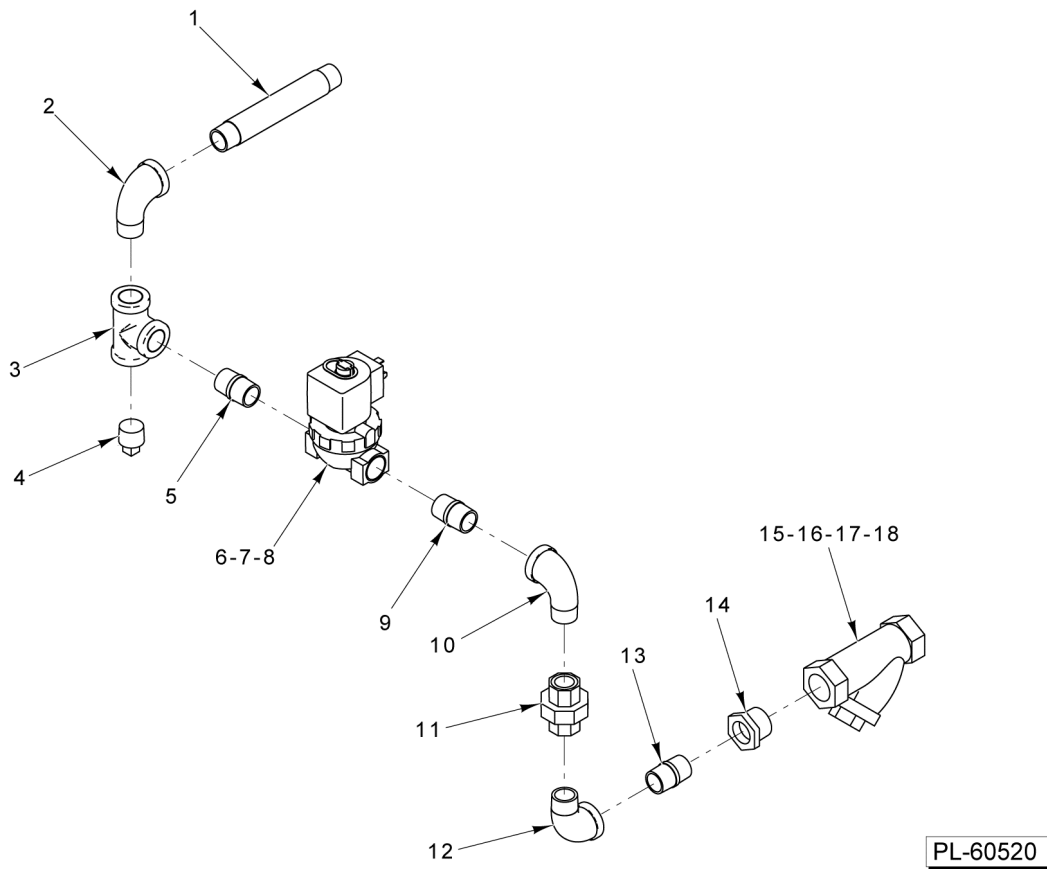

BOOSTER PIPING

BOOSTER PIPING

ILLUS.	PART NO.	NAME OF PART	AMT.
PL-60520			
1	0P-688325	Pipe 1/2 x 7 TBE (Brass).....	1
2	0P-688317	Elbow - Pipe 1/2 x 90 Deg. (Brass).....	1
3	0P-688318	Tee - Pipe 1/2 x 1/2 x 1/2 (Brass).....	1
4	0P-688322	Pipe Plug 1/2 Sq. Hd. (Brass).....	1
5	0P-688323	Pipe 1/2 x 1-1/4 TBE (Brass).....	1
6	0P-548093	Solenoid Valve (1/2) (120 V.).....	1
7	0P-548094	Service Kit - 1/2 Solenoid Valve.....	AR
8	0P-548085	Coil - Solenoid Valve (120 V.).....	1
9	0P-688323	Pipe 1/2 x 1-1/4 TBE (Brass).....	1
10	0P-688317	Elbow - Pipe 1/2 x 90 Deg. (Brass).....	1
11	0P-688319	Union - Pipe (Brass).....	1
12	0P-688317	Elbow - Pipe 1/2 x 90 Deg. (Brass).....	1
13	0P-688323	Pipe 1/2 x 1-1/4 TBE (Brass).....	1
14	0P-688320	Bushing - Pipe 3/4 to 1/2 (Brass).....	1
15	0P-638036	Strainer - Line (3/4 In.) (Brass) (Incls. Items 16, 17, & 18).....	1
16	0P-688037	Plug - Branch.....	1
17	0P-688039	Screen - Line Strainer.....	1
18	0P-578038	0P-578038.....	1

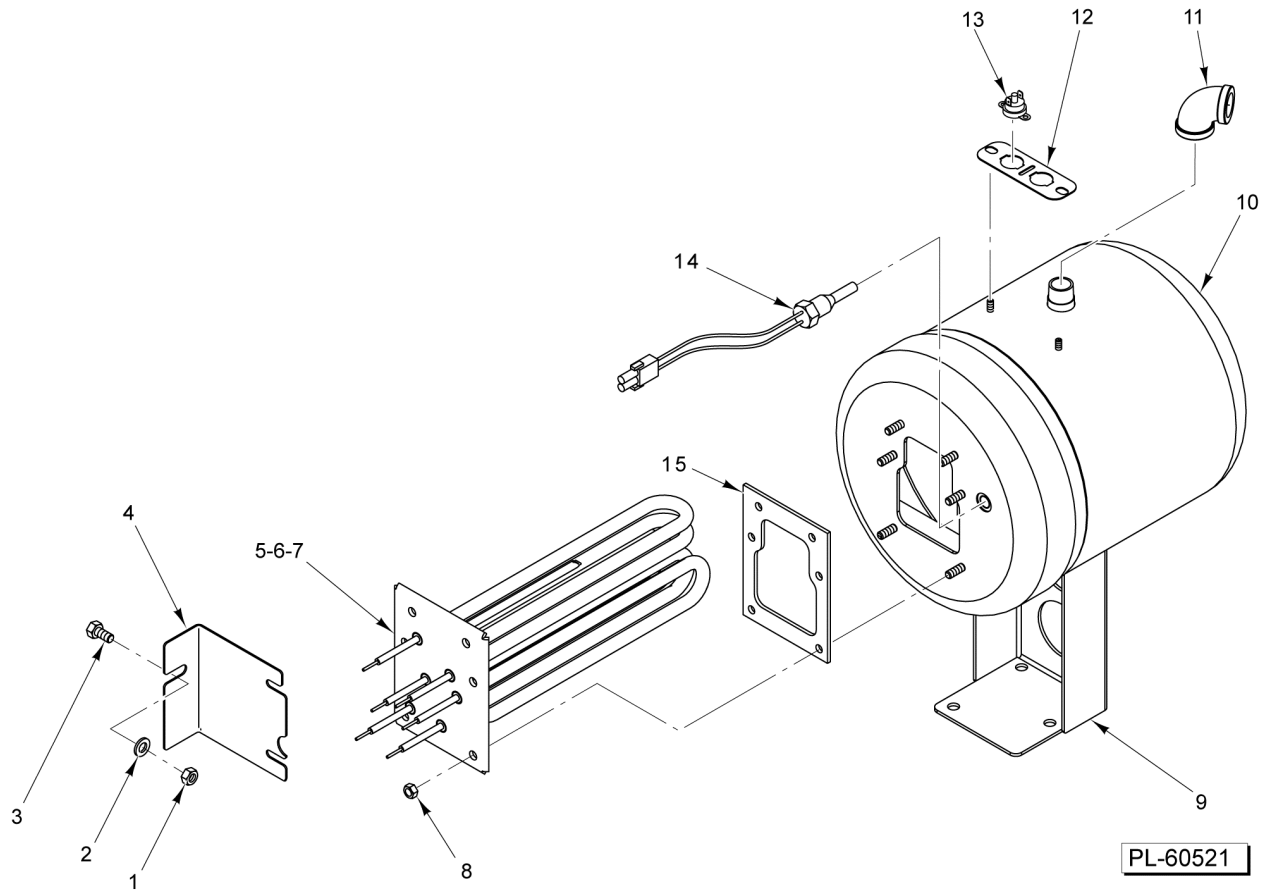

ELECTRIC BOOSTER TANK

ELECTRIC BOOSTER TANK

ILLUS.	PART NO.	NAME OF PART	AMT.
PL-60521			
1	0P-678142	Stop Nut 5/16-18 Hex (SST).....	1
2	0P-678169	Washer (SST).....	1
3	0P-678340	Cap Screw 5/16-18 x 3/4 Hex Hd. (SST).....	1
4	0A-108281	Bracket - Booster Support.....	1
5	0P-558276	Heater (240 V., 8.5 kW).....	1
6	0P-558275	Heater (208V., 8.5 kW).....	1
7	0P-558277	Heater (480 V., 8.5 kW).....	1
8	0P-678332	Nut 1/4-20 Hex (Brass).....	6
9	0A-108282	Bracket - Booster Mounting.....	1
10	0B-108269	Tank - Booster Weldment.....	1
11	0P-688317	Elbow - Pipe 1/2 x 90 Deg. (Brass).....	1
12	0A-108280	Bracket - High Limit.....	1
13	0P-658205	Protector - High Limit Protector - High Limit.....	2
14	0P-658206	Probe Assy. - Rinse.....	1
15	0P-578215	Gasket (13 kW) (Electric Heater).....	1

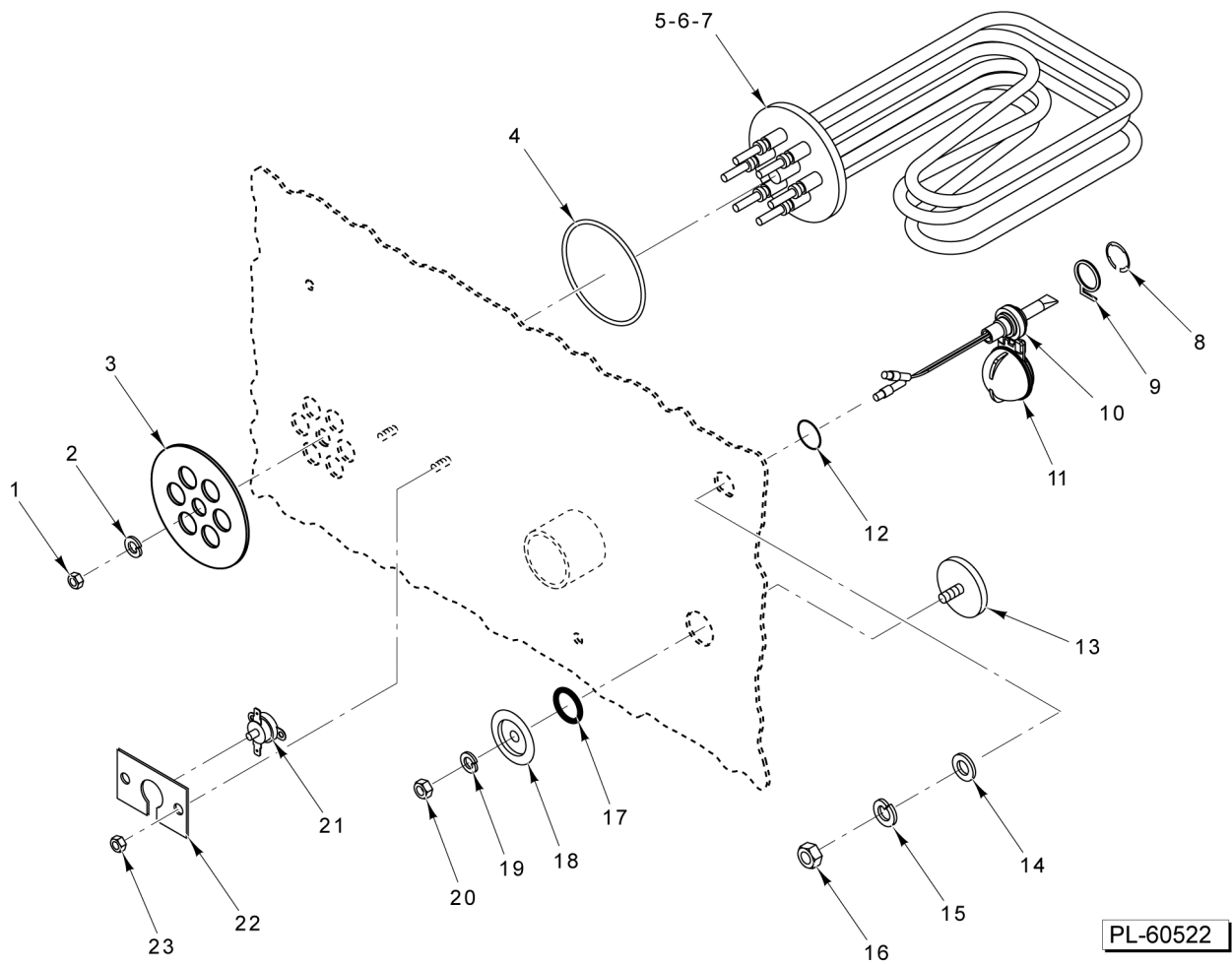

PL-60522

LOW WATER PROTECTION AND ELECTRIC HEAT

LOW WATER PROTECTION AND ELECTRIC HEAT

ILLUS. PL-60522	PART NO.	NAME OF PART	AMT.
1	0P-678333	Nut 3/8-16 (Brass) (Supplied With Heater).....	1
2	0P-678350	Lockwasher 3/8 Helical (SST).....	1
3	0B-108216	Plate - Electric Heat.....	1
4	0P-578174	O-Ring.....	1
5	0P-558251	Element - Heater Wash Tank (6 kW) (200 V) Element - Heater (6.2 kW) (208 V.).....	AR
6	0P-558249	Element - Heater (5 kW) (200-240 V., 50/60 Hz., 1 & 3 Ph.) Element - Heater (5 kW) (200-240 V., 60 Hz., 1 & 3 Ph.).....	1
7	0P-558250	Element - Heater (480 V.) Element - Heater (5 kW) (480 V., 60 Hz., 3 Ph.).....	1
8	0P-678337	Retaining Ring.....	1
9	0A-108184	Retainer - Float.....	1
10	0C-108278	Switch & Probe Assy. (4-Wire) (Short) (Incls. Items 9 & 11).....	1
11	0C-108192	Float Assy.....	1
12	0P-578175	O-Ring.....	1
13	0B-108190	Cap & Stud Assy.....	1
14	0P-678354	Washer - Thrust.....	1
15	0P-678353	Lockwasher 1/2 External Shakeproof (SST).....	1
16	0P-678334	Jam Nut 1/2-20 Hex (SST).....	1
17	0P-578173	O-Ring.....	1
18	0A-108191	Retainer - Cap.....	1
19	0P-678164	Lockwasher 1/4 Helical (SST).....	1
20	0P-678138	Nut 1/4-20 Hex (SST).....	1
21	0P-658202	Control - Temperature.....	1
22	0A-108209	Bracket - High Limit.....	1
23	0P-678335	Stop Nut 10-24 Hex Elastic (SST).....	2

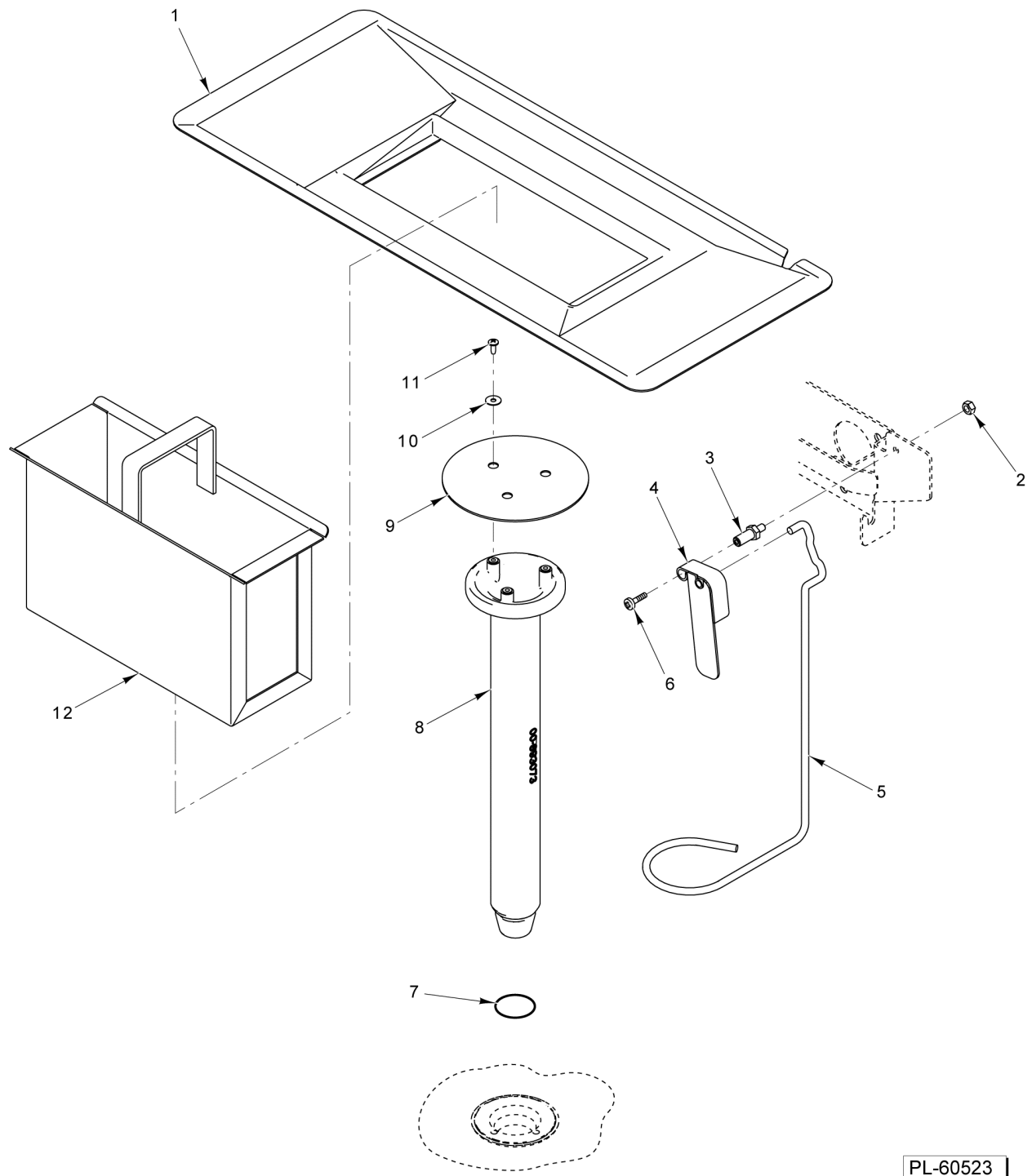

PL-60523

DRAIN UNIT

DRAIN UNIT

ILLUS.	PART NO.	NAME OF PART	AMT.
PL-60523			
1	0A-108232	Strainer Pan.....	1
2	0P-678143	Cotter Pin 1/16 x 1/2 (SST).....	1
3	0A-108189	Axle - Drain Lever.....	1
4	0A-108244	Drain Lever Assy.....	1
5	0A-108247	Drain - Lift.....	1
6	0P-678344	Mach. Screw 10-24 x 1/2 Phil. Truss Hd. (SST).....	1
7	0P-578177	O-Ring.....	1
8	0A-108241	Drain Tube Assy.....	1
9	0A-108242	Cover - Standpipe.....	1
10	0P-678355	Washer.....	3
11	0P-678349	Self-Tapping Screw 10-24 x 1/2 Phil. Truss Hd., Type F (SST).....	3
12	0A-108187	Strainer Basket Assy.....	1

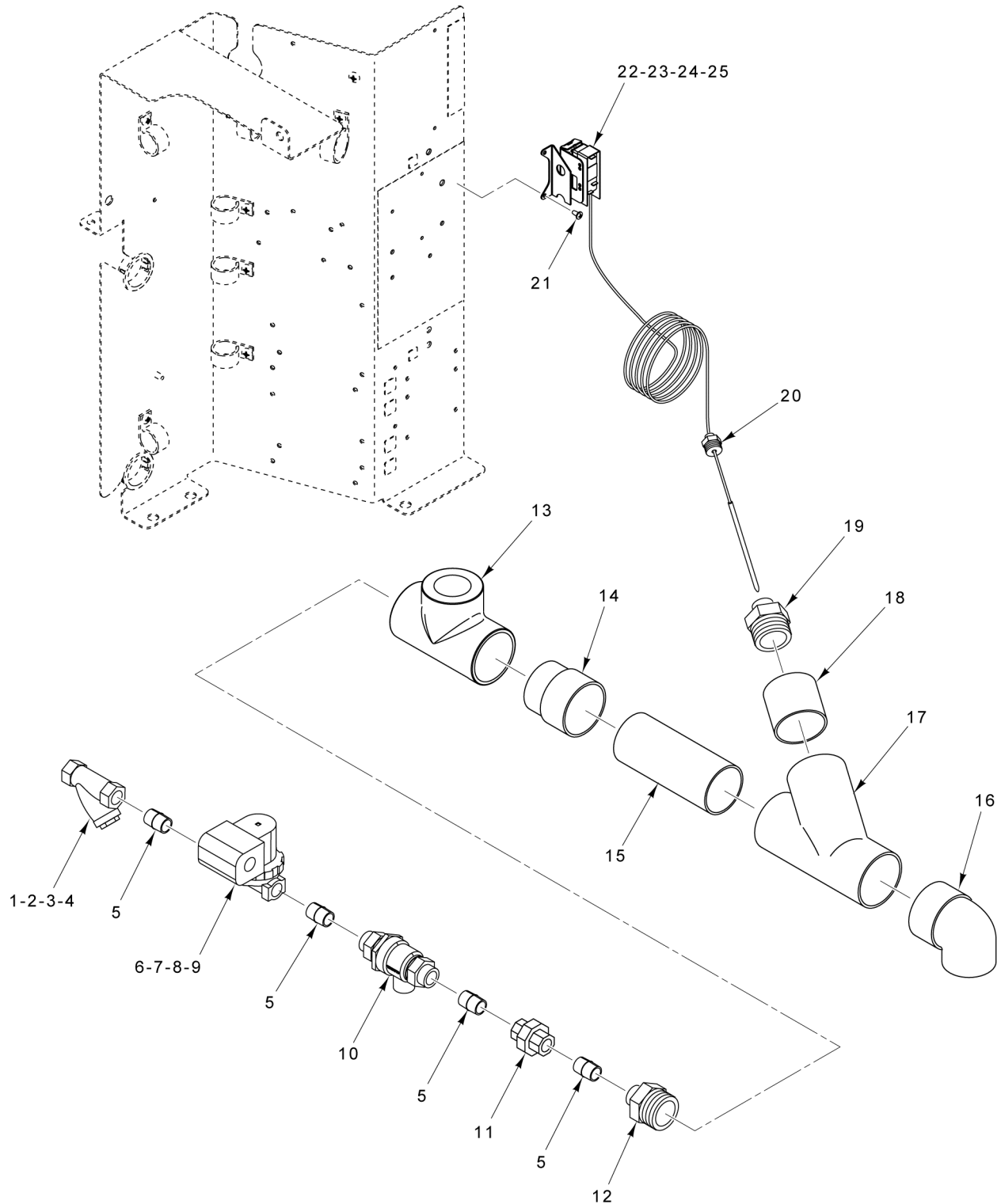

PL-60524

**DRAIN WATER TEMPERING
(OPTIONAL ACCESSORY)**

**DRAIN WATER TEMPERING
(OPTIONAL ACCESSORY)**

ILLUS.	PART NO.	NAME OF PART	AMT.
PL-60524			
1	0P-638193	Strainer - Line (1/2) (Brass) (Incls. Items 2, 3, & 4).....	1
2	0A-108194	Plug - Branch.....	1
3	0P-638194	Screen - Strainer (1/2 In.).....	1
4	0P-578195	Gasket.....	1
5	0P-688135	Pipe 1/2 x 1-1/8 TBE (Brass).....	4
6	0P-548270	Valve - Solenoid (1/2) (120 V.).....	1
7	0P-548093	Solenoid Valve (1/2) (120 V.) (Incls. Item 8).....	1
8	0P-548085	Coil - Solenoid Valve (120 V.).....	1
9	0P-548094	Service Kit - 1/2 Solenoid Valve.....	1
10	0P-628093	Backflow Preventer.....	1
11	0P-688319	Union - Pipe (Brass).....	1
12	0P-688321	Adapter 1-1/2 Brass to 1/2 FPT.....	1
13	0P-688328	Tee 1-1/2 x 1-1/2 x 1-1/2 (CPVC).....	1
14	0P-688265	Adapter - Male 1-1/2 (CPVC).....	1
15	0P-688272	Pipe 1-1/2 x 2-1/2 (CPVC).....	1
16	0P-688330	Elbow 1-1/2 x 90 Deg. (CPVC).....	1
17	0P-688331	Y-Fitting 1-1/2 (CPVC).....	1
18	0P-688271	Pipe 1-1/2 x 6 (CPVC).....	1
19	0P-688329	Adapter 1-1/2 CPVC to 1 FPT.....	1
20	0P-688327	Bushing - Pipe 1 to 3/8.....	1
21	0P-678160	Self-Tapping Screw 8-18 x 3/8 Phil. Bndg. Hd., Type B.....	2
22	0P-658204	Thermostat (120 Deg.).....	1
23	0P-458273	Cable Assy.....	1
24	0P-458274	Wire (Transformer to Thermostat).....	1
25	0P-458180	Wire Tie.....	AR

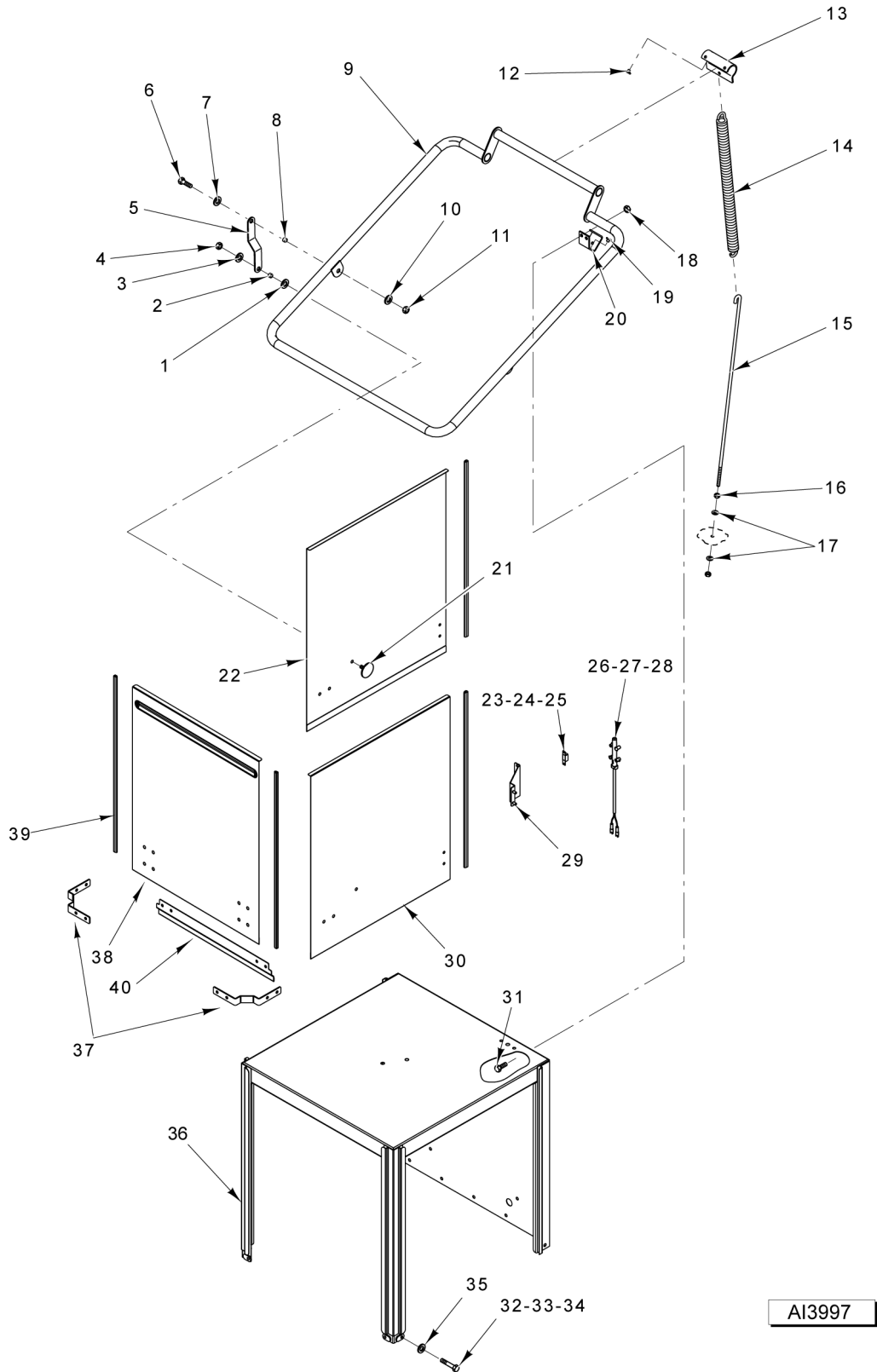

AI3997

DOOR ASSEMBLY

DOOR ASSEMBLY

ILLUS.	PART NO.	NAME OF PART	AMT.
PL-AI3997			
1	0P-678169	Washer (SST).....	2
2	0A-108091	Spacer - Door Link (Lower).....	2
3	0P-678169	Washer (SST).....	2
4	0P-678142	Stop Nut 5/16-18 Hex (SST).....	2
5	0A-108097	Link - Door Handle.....	2
6	0P-678150	0P-678150.....	2
7	0P-678169	Washer (SST).....	2
8	0A-108090	Spacer Door Link (Upper).....	2
9	0B-108233	Handle - Weldment.....	1
10	0P-678169	Washer (SST).....	2
11	0P-678142	Stop Nut 5/16-18 Hex (SST).....	2
12	0P-668017	Button - Bearing.....	4
13	0A-108087	Hanger - Counterbalance (Spring).....	1
14	0P-608088	Spring - Extension (Door).....	1
15	0A-108089	Hook - Spring.....	1
16	0P-678139	Nut 5/16-18 Hex (SST).....	3
17	0P-678169	Washer (SST).....	2
18	0P-678142	Stop Nut 5/16-18 Hex (SST).....	4
19	0P-668017	Button - Bearing.....	4
20	0A-108096	Support - Handle.....	2
21	0A-108257	Stiffener - Door Plate.....	2
22	0C-108115	Door Assy. (LH).....	1
23	0A-108013	Magnet.....	1
24	0P-678141	Stop Nut 6-32 Hex (SST).....	2
25	0A-108095	Magnet - Mount.....	1
26	0B-108113	Switch - Reed (Interlock).....	1
27	0P-678141	Stop Nut 6-32 Hex (SST).....	4
28	0P-528129	Connector - Strain Relief.....	1
29	0A-108083	Bracket - Magnet.....	1
30	0C-108114	Door Assy. (RH).....	1
31	0P-678339	Cap Screw 5/16-18 x 1/2 Hex Hd. (SST).....	4
32	0P-678152	Cap Screw 5/16-18 x 1-1/4 Hex Hd. (SST).....	AR
33	0P-678155	Mach. Screw 5/16-18 x 3/4 Truss Hd. (SST).....	AR
34	0P-678139	Nut 5/16-18 Hex (SST).....	AR
35	0P-678165	Lockwasher 5/16 Helical (SST).....	AR
36	0A-108302	Chamber - Weldment (Upper).....	1
37	0A-108305	Bracket.....	2
38	0A-108304	Door Assy. (Front).....	1
39	0P-578183	Guide - Door.....	4
40	0A-108578	Deflector, Splash Out, Door.....	1

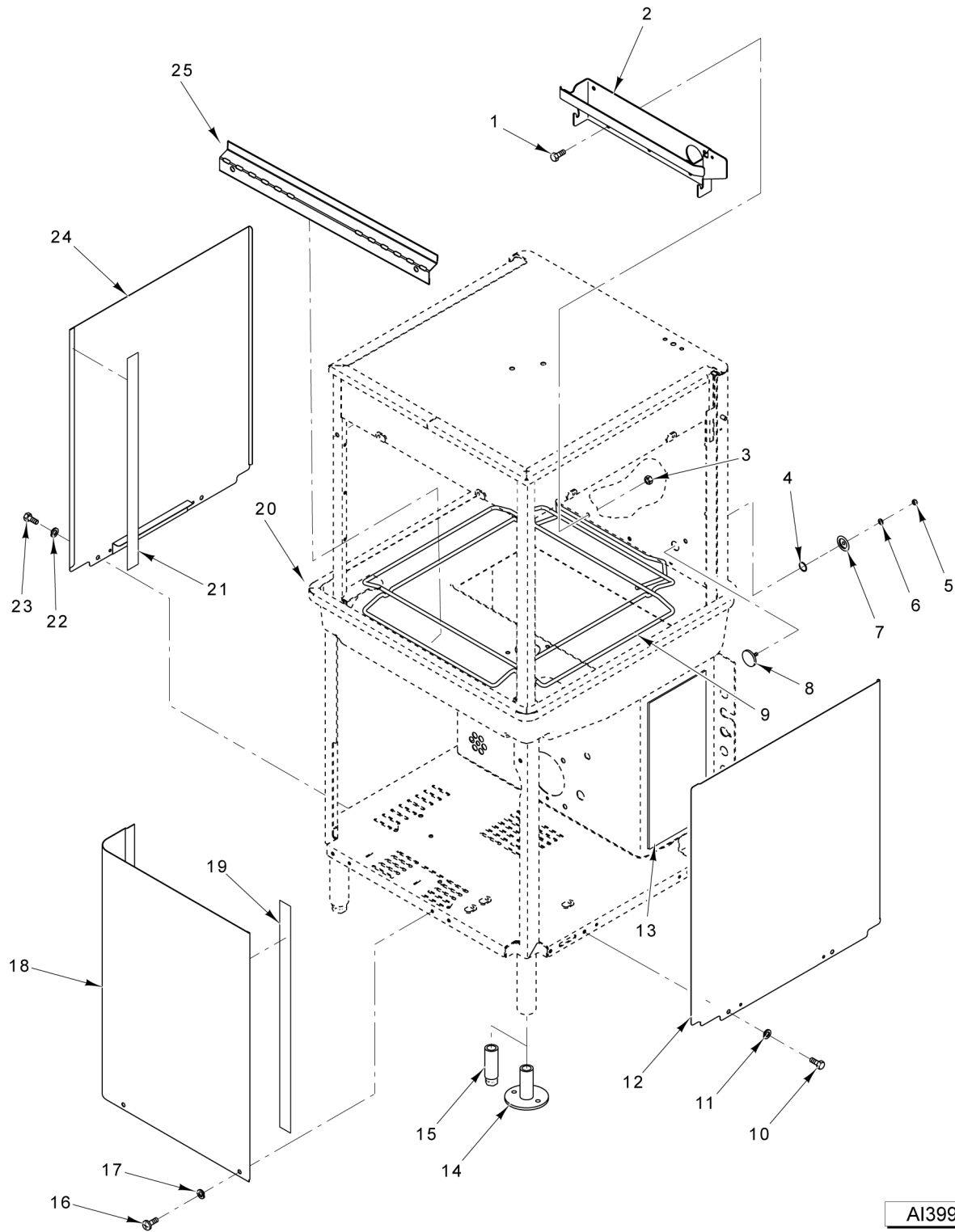

AI3996

PANELS AND RACK SUPPORT

PANELS AND RACK SUPPORT

ILLUS.	PART NO.	NAME OF PART	AMT.
PL-AI3996			
1	0P-678149	Cap Screw 5/16-18 x 5/8 Hex Hd. (SST).....	5
2	0A-108264	Rack - Stop Assy.....	1
3	0P-678142	Stop Nut 5/16-18 Hex (SST).....	5
4	0P-578173	O-Ring.....	1
5	0P-678138	Nut 1/4-20 Hex (SST).....	1
6	0P-678164	Lockwasher 1/4 Helical (SST).....	1
7	0A-108191	Retainer - Cap.....	1
8	0B-108190	Cap & Stud Assy.....	1
9	0P-458263	Wireform Assy.....	1
10	0P-678342	Cap Screw 1/4-20 x 1/2 Hex Hd. (SST).....	2
11	0P-678164	Lockwasher 1/4 Helical (SST).....	2
12	0A-108230	Panel - Cover (Right Side).....	1
13	0P-578266	Kit - Foam Installation.....	AR
14	0A-108252	Foot - Flanged (With Holes).....	4
15	0A-108253	Foot - Standard.....	4
16	0P-678345	Mach. Screw 1/4-20 x 1/2 Phil. Truss Hd.....	2
17	0P-678164	Lockwasher 1/4 Helical (SST).....	2
18	0A-108229	Panel - Cover (Front).....	1
19	0P-578212	Foam Tape.....	AR
20	0P-578224	Seal - Extrusion.....	AR
21	0P-578212	Foam Tape.....	AR
22	0P-678164	Lockwasher 1/4 Helical (SST).....	2
23	0P-678342	Cap Screw 1/4-20 x 1/2 Hex Hd. (SST).....	2
24	0A-108223	Panel - Cover (Left Side).....	1
25	0A-108579	Deflector, Splash Out, Tank.....	1

