



# LCD-TV

Chassis : N83D

Model : LN26C450E1H  
LN32C450E1H  
LN26C459E1H  
LN32C459E1H  
LN40C530F1H  
LN37C539F1H  
LN40C539F1H  
LN46C539F1H

# *SERVICE* Manual

## TFT-LCD TV



LN40C539F1H

## Contents

1. Precautions
2. Product specifications
3. Disassembly and Reassembly
4. Troubleshooting
5. Exploded View & Part List
6. Wiring Diagram

# Contents

<b>1. Precautions</b> .....	<b>1-1</b>
1-1. Safety Precautions .....	1-1
1-2. Servicing Precautions .....	1-2
1-3. Electrostatically Sensitive Devices (ESD) Precautions .....	1-2
1-4. Installation Precautions .....	1-3
<b>2. Product specifications</b> .....	<b>2-1</b>
2-1. Feature & Specifications .....	2-1
2-2. Specification Comparison to Old Models .....	2-8
2-3. Accessories .....	2-10
<b>3. Disassembly and Reassembly</b> .....	<b>3-1</b>
3-1. Disassembly and Reassembly .....	3-1
<b>4. Troubleshooting</b> .....	<b>4-1</b>
4-1. Troubleshooting .....	4-1
4-2. Alignments and Adjustments .....	4-29
4-3. Factory Mode Adjustments .....	4-30
4-4. Setting the Hotel Option Data .....	4-36
4-6. White Balance - Calibration .....	4-40
4-7. White Ratio (Balance) Adjustment .....	4-42
4-8. Servicing Information .....	4-44
<b>5. Exploded View &amp; Part List</b> .....	<b>5-1</b>
5-1. LN26C450E1H / LN26C459E1H Exploded View .....	5-1
5-2-1. LN26C450E1H Parts List .....	5-3
5-2-2. LN26C459E1H Parts List .....	5-9
5-3. LN32C450E1H / LN32C459E1H Exploded View .....	5-15
5-4-1. LN32C450E1H Parts List .....	5-17
5-4-2. LN32C459E1H Parts List .....	5-23
5-5. LN37C539F1H Exploded View .....	5-29
5-6. LN37C539F1H Parts List .....	5-31
5-7. LN40C530F1H/LN40C539F1H Exploded View .....	5-37
5-8-1. LN40C530F1H Parts List .....	5-39
5-8-2. LN40C539F1H Parts List .....	5-45
5-9. LN46C539F1H Exploded View .....	5-51
5-10. LN46C539F1H Parts List .....	5-53
<b>6. Wiring Diagram</b> .....	<b>6-1</b>
6-1. Wiring Diagram .....	6-1
6-2. Connector .....	6-3
6-3. Connector Functions .....	6-5
6-4. Cables .....	6-5



**GSPN (Global Service Partner Network)**

Area	Web Site
North America	<a href="http://service.samsungportal.com">http://service.samsungportal.com</a>
Latin America	<a href="http://latin.samsungportal.com">http://latin.samsungportal.com</a>
CIS	<a href="http://cis.samsungportal.com">http://cis.samsungportal.com</a>
Europe	<a href="http://europe.samsungportal.com">http://europe.samsungportal.com</a>
China	<a href="http://china.samsungportal.com">http://china.samsungportal.com</a>
Asia	<a href="http://asia.samsungportal.com">http://asia.samsungportal.com</a>
Mideast & Africa	<a href="http://mea.samsungportal.com">http://mea.samsungportal.com</a>

**This Service Manual is a property of Samsung Electronics Co.,Ltd.**  
Any unauthorized use of Manual can be punished under applicable  
International and/or domestic law.

© 2010 Samsung Electronics Co.,Ltd.  
All rights reserved.  
Printed in Korea  
P/N: BN82-00860A-00

# 1. Precautions

## 1-1. Safety Precautions

Follow these safety, servicing, and ESD precautions to prevent damage and to protect against potential hazards such as electrical shock.

### 1-1-1. Warnings

1. For continued safety, do not attempt to modify any circuitry.

### 1-1-2. Servicing the LCD TV

1. When servicing the LCD TV, Disconnect the AC line cord from the AC outlet.
2. It is essential that service technicians have an accurate voltage meter available at all times. Check the calibration of this meter periodically.

### 1-1-3. Fire and Shock Hazard

Before returning the LCD TV to the user, perform the following safety checks:

1. Inspect each lead dress to make certain that the leads are not pinched or that hardware is not lodged between the chassis and other metal parts in the LCD TV.
2. Inspect all protective devices such as nonmetallic control knobs, insulating materials, cabinet backs, adjustment and compartment covers or shields, isolation resistor capacitor networks, mechanical insulators, etc.
3. Leakage Current Hot Check (Figure 1-1):  
**WARNING** : Do not use an isolation transformer during this test.  
 Use a leakage current tester or a metering system that complies with American National Standards Institute (ANSI C101.1, Leakage Current for Appliances), and Underwriters Laboratories (UL Publication UL1410, 59.7).
4. With the unit completely reassembled, plug the AC line cord directly into a 120V AC outlet. With the unit's AC switch

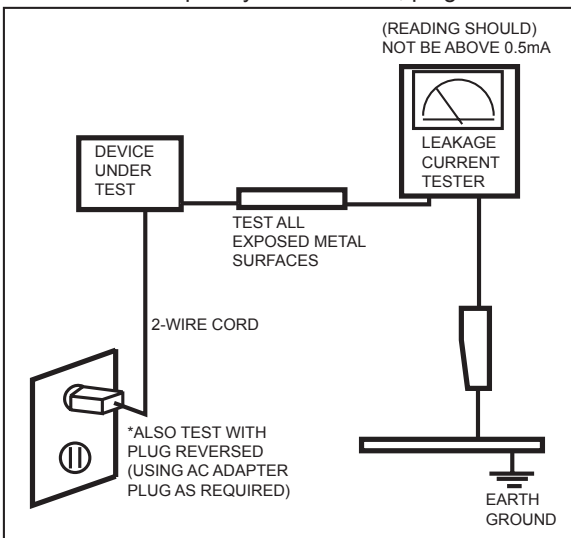



Figure 1-1. Leakage Current Test Circuit

first in the ON position and then OFF, measure the current between a known earth ground (metal water pipe, conduit, etc.) and all exposed metal parts, including: metal cabinets, screwheads and control shafts.

The current measured should not exceed 0.5 milliamp.

Reverse the power-plug prongs in the AC outlet and repeat the test.

### 1-1-4. Product Safety Notices

Some electrical and mechanical parts have special safety related characteristics which are often not evident from visual inspection. The protection they give may not be obtained by replacing them with components rated for higher voltage, wattage, etc. Parts that have special safety characteristics are identified by  on schematics and parts lists. A substitute replacement that does not have the same safety characteristics as the recommended replacement part might create shock, fire and/or other hazards. Product safety is under review continuously and new instructions are issued whenever appropriate.

## 1-2. Servicing Precautions

**WARNING:** An electrolytic capacitor installed with the wrong polarity might explode.

**Caution:** Before servicing units covered by this service manual, read and follow the Safety Precautions section of this manual.

**Note:** If unforeseen circumstances create conflict between the following servicing precautions and any of the safety precautions, always follow the safety precautions.

### 1-2-1 General Servicing Precautions

1. Always unplug the unit's AC power cord from the AC power source and disconnect the DC Power Jack before attempting to:  
(a) remove or reinstall any component or assembly, (b) disconnect PCB plugs or connectors, (c) connect a test component in parallel with an electrolytic capacitor.
2. Some components are raised above the printed circuit board for safety. An insulation tube or tape is sometimes used. The internal wiring is sometimes clamped to prevent contact with thermally hot components. Reinstall all such elements to their original position.
3. After servicing, always check that the screws, components and wiring have been correctly reinstalled. Make sure that the area around the serviced part has not been damaged.
4. Check the insulation between the blades of the AC plug and accessible conductive parts (examples: metal panels, input terminals and earphone jacks).
5. Insulation Checking Procedure: Disconnect the power cord from the AC source and turn the power switch ON. Connect an insulation resistance meter (500 V) to the blades of the AC plug. The insulation resistance between each blade of the AC plug and accessible conductive parts (see above) should be greater than 1 mega ohm.
6. Always connect a test instrument's ground lead to the instrument chassis ground before connecting the positive lead; always remove the instrument's ground lead last.
7. **Caution:** Danger of explosion if battery is incorrectly replaced. Replace only with the same or equivalent type.

## 1-3. Electrostatically Sensitive Devices (ESD) Precautions

Some semiconductor (solid state) devices can be easily damaged by static electricity. Such components are commonly called Electrostatically Sensitive Devices (ESD). Examples of typical ESD are integrated circuits and some field-effect transistors. The following techniques will reduce the incidence of component damage caused by static electricity.

1. Immediately before handling any semiconductor components or assemblies, drain the electrostatic charge from your body by touching a known earth ground. Alternatively, wear a discharging wrist-strap device. To avoid a shock hazard, be sure to remove the wrist strap before applying power to the LCD TV.
2. After removing an ESD-equipped assembly, place it on a conductive surface such as aluminum foil to prevent accumulation of an electrostatic charge.
3. Do not use freon-propelled chemicals. These can generate electrical charges sufficient to damage ESDs.
4. Use only a grounded-tip soldering iron to solder or desolder ESDs.
5. Use only an anti-static solder removal device. Some solder removal devices not classified as "anti-static" can generate electrical charges sufficient to damage ESDs.
6. Do not remove a replacement ESD from its protective package until you are ready to install it. Most replacement ESDs are packaged with leads that are electrically shorted together by conductive foam, aluminum foil or other conductive materials.
7. Immediately before removing the protective material from the leads of a replacement ESD, touch the protective material to the chassis or circuit assembly into which the device will be installed.  
**Caution:** Be sure no power is applied to the chassis or circuit and observe all other safety precautions.
8. Minimize body motions when handling unpackaged replacement ESDs. Motions such as brushing clothes together, or lifting your foot from a carpeted floor can generate enough static electricity to damage an ESD.

## 1-4. Installation Precautions

1. For safety reasons, more than two people are required for carrying the product.

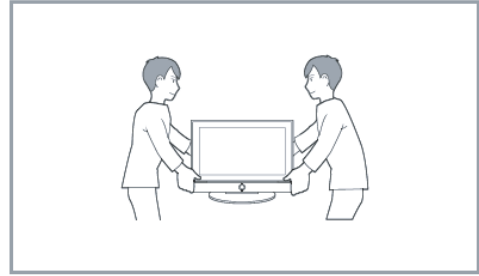

2. Keep the power cord away from any heat emitting devices, as a melted covering may cause fire or electric shock.
3. Do not place the product in areas with poor ventilation such as a bookshelf or closet. The increased internal temperature may cause fire.
4. Bend the external antenna cable when connecting it to the product. This is a measure to protect it from being exposed to moisture. Otherwise, it may cause a fire or electric shock.
5. Make sure to turn the power off and unplug the power cord from the outlet before repositioning the product. Also check the antenna cable or the external connectors if they are fully unplugged. Damage to the cord may cause fire or electric shock.
6. Keep the antenna far away from any high-voltage cables and install it firmly. Contact with the high-voltage cable or the antenna falling over may cause fire or electric shock.
7. When installing the product, leave enough space (0.1m) between the product and the wall for ventilation purposes. A rise in temperature within the product may cause fire.

## 2. Product specifications

### 2-1. Feature & Specifications

Model	LN26C450E1H / LN26C459E1H	
Feature		
<ul style="list-style-type: none"> <li>▶ Digital-TV, RF, 3-HDMI, 1-Component, 1-A/V, 1-USB2.0, D-SUB</li> <li>▶ Brightness : 450 cd/m<sup>2</sup></li> <li>▶ High Contrast Ratio :40,000:1</li> <li>▶ Response Time : 8.5ms</li> </ul>		
Specifications		
Item	Description	
LCD Panel	26inch HD 60Hz	
Scanning Frequency	Horizontal : 60 kHz ~ 73 kHz (Automatic) Vertical : 47 Hz ~ 63 Hz (Automatic)	
Display Colors	16.7M color	
Maximum resolution	Horizontal : 1366 Pixels Vertical : 768 pixels	
Input Signal	Analog 0.7 Vp-p ± 5% positive at 75Ω, internally terminated	
Input Sync Signal	H/V Separate, TTL, P. or N.	
Maximum Pixel Clock rate	76MHz	
Active Display Horizontal/Vertical	22.67 x 12.74 inches (575.769 (H) x 323.712 (V) mm)	
AC power voltage & Frequency	AC 100 ~ 240v, 50Hz/60Hz	
Power Consumption	Under 90W (Under 0.3W, Stand by)	
Dimensions Set (W x D x H)	25.5 x 8.8 x 18.7 inches (646.5 x 222.2 x 475.8 mm)_with stand 25.5 x 3.0 x 17.0 inches (646.5 x 77.0 x 432.3 mm)_without stand	
Weight	14.66 lbs (6.65kg)_with stand 13.76 lbs (6.24kg)_without stand	
TV System	Tuning	Frequency Synthesize (Refer to detailed Frequency Table)
	System	ATSC & Clear QAM
	Sound	NTSC-M, Dolby Digital*
Environmental Considerations	Operating Temperature : 32°F ~ 122°F (0°C ~ 50°C) Operating Humidity : 10% ~ 90% Storage temperature : -4°F ~ 140°F (-20°C ~ 60°C) Storage Humidity: 10% ~ 90%	
Audio Spec.	- MAX Internal Audio Output Power : Each 5W(Left/Right) - Equalizer : 5band - Output Frequency : RF : 20 Hz ~ 15.4 kHz AV/Componet/HDMI : 20 Hz ~ 20 kHz	
Pro:Idiom	450 Model : Pro:Idiom not supported 459 Model : Pro:Idiom supported	
<b>Note:</b> Dolby Digital*, Game Mode, Film Mode, Energy Saving, Anynet*		

Model	LN32C450E1H / LN32C459E1H	
Feature		
<ul style="list-style-type: none"> <li>▶ Digital-TV, RF, 3-HDMI, 1-Component, 1-A/V, 1-USB2.0, D-SUB</li> <li>▶ Brightness : 450cd/m<sup>2</sup></li> <li>▶ High Contrast Ratio : 40,000:1</li> <li>▶ Response Time : 8.5 ms</li> </ul>		
Specifications		
Item	Description	
LCD Panel	32inch HD 60Hz	
Scanning Frequency	Horizontal : 60 kHz ~ 73 kHz (Automatic) Vertical : 47 Hz ~ 63 Hz (Automatic)	
Display Colors	16.7M color	
Maximum resolution	Horizontal : 1366 Pixels Vertical : 768 pixels	
Input Signal	Analog 0.7 Vp-p ± 5% positive at 75Ω, internally terminated	
Input Sync Signal	H/V Separate, TTL, P. or N.	
Maximum Pixel Clock rate	76MHz	
Active Display Horizontal/Vertical	27.50 x 15.47 inches (698.4 (H) x 392.85 (V) mm)	
AC power voltage & Frequency	AC 100 ~ 240v, 50Hz/60Hz	
Power Consumption	Under 120W (Under 0.3W, Stand by)	
Dimensions Set (W x D x H)	30.9 x 9.7 x 22.8 inches (784.4 x 247.2 x 580.0 mm)_with stand 30.9 x 3.0 x 20.2 inches (784.4 x 76.1 x 514.2 mm)_without stand	
Weight	20.30 lbs (9.21kg)_with stand 18.96 lbs (8.6kg)_without stand	
TV System	Tuning	Frequency Synthesize (Refer to detailed Frequency Table)
	System	ATSC & Clear QAM
	Sound	NTSC-M, Dolby Digital*
Environmental Considerations	Operating Temperature : 32°F ~ 122°F (0°C ~ 50°C) Operating Humidity : 10% ~ 90% Storage temperature : -4°F ~ 140°F (-20°C ~ 60°C) Storage Humidity: 10% ~ 90%	
Audio Spec.	- MAX Internal Audio Output Power : Each 10W(Left/Right) - Equalizer : 5band - Output Frequency : RF : 20 Hz ~ 15.4 kHz AV/Componet/HDMI : 20 Hz ~ 20 kHz	
Pro:Idiom	450 Model : Pro:Idiom not supported 459 Model : Pro:Idiom supported	
<b>Note:</b> Dolby Digital*, Game Mode, Film Mode, Energy Saving, Anynet*		

Model	LN37C539F1H	
Feature		
<ul style="list-style-type: none"> <li>▶ Digital-TV, RF, 3-HDMI, 1-Component, 1-A/V, 1-USB2.0, D-SUB</li> <li>▶ Brightness : 500cd/m<sup>2</sup></li> <li>▶ High Contrast Ratio : 50,000:1</li> <li>▶ Response Time : 6.5ms</li> </ul>		
Specifications		
Item	Description	
LCD Panel	37inch FHD 60Hz	
Scanning Frequency	Horizontal : 60 kHz ~ 73 kHz (Automatic) Vertical : 47 Hz ~ 63 Hz (Automatic)	
Display Colors	16.7M color	
Maximum resolution	Horizontal : 1920 Pixels Vertical : 1080 pixels	
Input Signal	Analog 0.7 Vp-p ± 5% positive at 75Ω, internally terminated	
Input Sync Signal	H/V Separate, TTL, P. or N.	
Maximum Pixel Clock rate	74.25MHz	
Active Display Horizontal/Vertical	32.26 x 18.15 inches (819.36 (H) x 460.89 (V) mm)	
AC power voltage & Frequency	AC 100 ~ 240v, 50Hz/60Hz	
Power Consumption	Under 160W (Under 0.3W, Stand by)	
Dimensions Set (W x D x H)	35.5 x 9.4 x 24.2 inches ( 901.8x 240.0 x 613.6 mm)_with stand 35.5 x 3.0 x 22.1 inches (901.8 x 76.9 x 561.8 mm)_without stand	
Weight	31.39lbs (14.24kg)_with stand 25.00lbs (11.34kg)_without stand	
TV System	Tuning	Frequency Synthesize (Refer to detailed Frequency Table)
	System	ATSC & Clear QAM
	Sound	NTSC-M, Dolby Digital*
Environmental Considerations	Operating Temperature : 32°F ~ 122°F (0°C ~ 50°C) Operating Humidity : 10% ~ 90% Storage temperature : -4°F ~ 140°F (-20°C ~ 60°C) Storage Humidity: 10% ~ 90%	
Audio Spec.	- MAX Internal Audio Output Power : Each 10W(Left/Right) - Equalizer : 5band - Output Frequency : RF : 20 Hz ~ 15.4 kHz AV/Componet/HDMI : 20 Hz ~ 20 kHz	
Pro:Idiom	Pro:Idiom not supported	
<b>Note:</b> Dolby Digital*, Game Mode, Film Mode, Energy Saving, Anynet*		

2. Product specifications

Model	LN40C530F1H / LN40C539F1H	
Feature		
<ul style="list-style-type: none"> <li>▶ Digital-TV, RF, 3-HDMI, 1-Component, 1-A/V, 1-USB2.0, D-SUB</li> <li>▶ Brightness : 500cd/m<sup>2</sup></li> <li>▶ High Contrast Ratio : 50,000 :1</li> <li>▶ Response Time : 6.5ms</li> </ul>		
Specifications		
Item	Description	
LCD Panel	40inch FHD 60Hz	
Scanning Frequency	Horizontal : 60 kHz ~ 73 kHz (Automatic) Vertical : 47 Hz ~ 63 Hz (Automatic)	
Display Colors	16.7M color	
Maximum resolution	Horizontal : 1920 Pixels Vertical : 1080 pixels	
Input Signal	Analog 0.7 Vp-p ± 5% positive at 75Ω, internally terminated	
Input Sync Signal	H/V Separate, TTL, P. or N.	
Maximum Pixel Clock rate	74.25MHz	
Active Display Horizontal/Vertical	34.87 x 19.61 inches (885.6(H) x 498.15(V) mm)	
AC power voltage & Frequency	AC 100 ~ 240v, 50Hz/60Hz	
Power Consumption	Under 190 W (Under 0.3W, Stand by)	
Dimensions Set (W x D x H)	38.2 x 9.4 x 25.7 inches ( 970.0x 240.0 x 651.7 mm)_with stand 3.8 x 3.1 x 23.6 inches (970.0 x 78.6 x 600.1 mm)_without stand	
Weight	38.14lbs (17.3kg)_with stand 31.75lbs (14.4kg)_without stand	
TV System	Tuning	Frequency Synthesize (Refer to detailed Frequency Table)
	System	ATSC & Clear QAM
	Sound	NTSC-M, Dolby Digital*
Environmental Considerations	Operating Temperature : 32°F ~ 122°F (0°C ~ 50°C) Operating Humidity : 10% ~ 90% Storage temperature : -4°F ~ 140°F (-20°C ~ 60°C) Storage Humidity: 10% ~ 90%	
Audio Spec.	- MAX Internal Audio Output Power : Each 10W(Left/Right) - Equalizer : 5band - Output Frequency : RF : 20 Hz ~ 15.4 kHz AV/Componet/HDMI : 20 Hz ~ 20 kHz	
Pro:Idiom	530 Model : Pro:Idiom not supported 539 Model : Pro:Idiom supported	
<b>Note:</b> Dolby Digital*, Game Mode, Film Mode, Energy Saving, Anynet*		

Model	LN46C539F1H	
Feature		
<ul style="list-style-type: none"> <li>▶ Digital-TV, RF, 3-HDMI, 1-Component, 1-A/V, 1-USB2.0, D-SUB</li> <li>▶ Brightness : 500cd/m<sup>2</sup></li> <li>▶ High Contrast Ratio :50,000 :1</li> <li>▶ Response Time : 6.5ms</li> </ul>		
Specifications		
Item	Description	
LCD Panel	46inch FHD 60Hz	
Scanning Frequency	Horizontal : 60 kHz ~ 73 kHz (Automatic) Vertical : 47 Hz ~ 63 Hz (Automatic)	
Display Colors	16.7M color	
Maximum resolution	Horizontal : 1920 Pixels Vertical : 1080 pixels	
Input Signal	Analog 0.7 Vp-p ± 5% positive at 75Ω, internally terminated	
Input Sync Signal	H/V Separate, TTL, P. or N.	
Maximum Pixel Clock rate	74.25MHz	
Active Display Horizontal/Vertical	40.08 x 22.55 inches (1018.08(H) x 572.67(V) mm)	
AC power voltage & Frequency	AC 100 ~ 240v, 50Hz/60Hz	
Power Consumption	Under 210W (Under 0.3W, Stand by)	
Dimensions Set (W x D x H)	43.4 x 10.2 x 28.9 inches ( 1102.4x 260.1 x 733.2 mm)_with stand 43.4 x 3.1 x 26.6 inches (1102.4 x 78.4 x 676.3 mm)_without stand	
Weight	45.50lbs (20.64kg)_withstand 36.90lbs (16.74kg)_without stand	
TV System	Tuning	Frequency Synthesize (Refer to detailed Frequency Table)
	System	ATSC & Clear QAM
	Sound	NTSC-M, Dolby Digital*
Environmental Considerations	Operating Temperature : 32°F ~ 122°F (0°C ~ 50°C) Operating Humidity : 10% ~ 90% Storage temperature : -4°F ~ 140°F (-20°C ~ 60°C) Storage Humidity: 10% ~ 90%	
Audio Spec.	- MAX Internal Audio Output Power : Each 10W(Left/Right) - Equalizer : 5band - Output Frequency : RF : 20 Hz ~ 15.4 kHz AV/Componet/HDMI : 20 Hz ~ 20 kHz	
Pro:Idiom	Pro:Idiom supported	
<b>Note:</b> Dolby Digital*, Game Mode, Film Mode, Energy Saving, Anynet*		

**CHANNEL FREQUENCY TABLE**

1. OUTPUT FREQUENCY : ANALOG fv:45.75MHz, fs:41.25MHz    DIGITAL Fc:44MHz



2. TUNING STEP SIZE    : FIRST PLL 250KHz    SECOND PLL 62.5KHz

OSD	CH NO	AIR		BAND	CH NO	Cable STD	BAND	CH NO	Cable HRC	CH NO	Cable IRC
		Air-DTV	Air-NTSC								
1	1							A-8	72.00	A-8	73.25
2	2	57	55.25	V-L	2	55.25	V-L	2	54.00	2	55.25
3	3	63	61.25	V-L	3	61.25	V-L	3	60.00	3	61.25
4	4	69	67.25	V-L	4	67.25	V-L	4	66.00	4	67.25
5	5	79	77.25	V-L	5	77.25	V-L	A-7	78.00	A-7	79.25
6	6	85	83.25	V-L	6	83.25	V-L	A-6	84.00	A-6	85.25
7	7	177	175.25	V-H	7	175.25	V-H	7	174.00	7	175.25
8	8	183	181.25	V-H	8	181.25	V-H	8	180.00	8	181.25
9	9	189	187.25	V-H	9	187.25	V-H	9	186.00	9	187.25
10	10	195	193.25	V-H	10	193.25	V-H	10	192.00	10	193.25
11	11	201	199.25	V-H	11	199.25	V-H	11	198.00	11	199.25
12	12	207	205.25	V-H	12	205.25	V-H	12	204.00	12	205.25
13	13	213	211.25	V-H	13	211.25	V-H	13	210.00	13	211.25
14	14	473	471.25	UHF	A	121.25	MID	A	120.00	A	121.25
15	15	479	477.25	UHF	B	127.25	MID	B	126.00	B	127.25
16	16	485	483.25	UHF	C	133.25	MID	C	132.00	C	133.25
17	17	491	489.25	UHF	D	139.25	MID	D	138.00	D	139.25
18	18	497	495.25	UHF	E	145.25	MID	E	144.00	E	145.25
19	19	503	501.25	UHF	F	151.25	MID	F	150.00	F	151.25
20	20	509	507.25	UHF	G	157.25	MID	G	156.00	G	157.25
21	21	515	513.25	UHF	H	163.25	MID	H	162.00	H	163.25
22	22	521	519.25	UHF	I	169.25	MID	I	168.00	I	169.25
23	23	527	525.25	UHF	J	175.25	SUPER	J	174.00	J	175.25
24	24	533	531.25	UHF	K	181.25	SUPER	K	180.00	K	181.25
25	25	539	537.25	UHF	L	187.25	SUPER	L	186.00	L	187.25
26	26	545	543.25	UHF	M	193.25	SUPER	M	192.00	M	193.25
27	27	551	549.25	UHF	N	199.25	SUPER	N	198.00	N	199.25
28	28	557	555.25	UHF	O	205.25	SUPER	O	204.00	O	205.25
29	29	563	561.25	UHF	P	211.25	SUPER	P	210.00	P	211.25
30	30	569	567.25	UHF	Q	217.25	SUPER	Q	216.00	Q	217.25
31	31	575	573.25	UHF	R	223.25	SUPER	R	222.00	R	223.25
32	32	581	579.25	UHF	S	229.25	SUPER	S	228.00	S	229.25
33	33	587	585.25	UHF	T	235.25	SUPER	T	234.00	T	235.25
34	34	593	591.25	UHF	U	241.25	SUPER	U	240.00	U	241.25
35	35	599	597.25	UHF	V	247.25	SUPER	V	246.00	V	247.25
36	36	605	603.25	UHF	W	253.25	SUPER	W	252.00	W	253.25
37	37	611	609.25	UHF	AA	259.25	HYPER	AA	258.00	AA	259.25
38	38	617	615.25	UHF	BB	265.25	HYPER	BB	264.00	BB	265.25
39	39	623	621.25	UHF	CC	271.25	HYPER	CC	270.00	CC	271.25
40	40	629	627.25	UHF	DD	277.25	HYPER	DD	276.00	DD	277.25
41	41	635	633.25	UHF	EE	283.25	HYPER	EE	282.00	EE	283.25
42	42	641	639.25	UHF	FF	289.25	HYPER	FF	288.00	FF	289.25
43	43	647	645.25	UHF	GG	295.25	HYPER	GG	294.00	GG	295.25
44	44	653	651.25	UHF	HH	301.25	HYPER	HH	300.00	HH	301.25
45	45	659	657.25	UHF	II	307.25	HYPER	II	306.00	II	307.25
46	46	665	663.25	UHF	JJ	313.25	HYPER	JJ	312.00	JJ	313.25
47	47	671	669.25	UHF	KK	319.25	HYPER	KK	318.00	KK	319.25
48	48	677	675.25	UHF	LL	325.25	HYPER	LL	324.00	LL	325.25
49	49	683	681.25	UHF	MM	331.25	HYPER	MM	330.00	MM	331.25
50	50	689	687.25	UHF	NN	337.25	HYPER	NN	336.00	NN	337.25
51	51	695	693.25	UHF	OO	343.25	HYPER	OO	342.00	OO	343.25
52	52	701	699.25	UHF	PP	349.25	HYPER	PP	348.00	PP	349.25
53	53	707	705.25	UHF	QQ	355.25	HYPER	QQ	354.00	QQ	355.25
54	54	713	711.25	UHF	RR	361.25	HYPER	RR	360.00	RR	361.25
55	55	719	717.25	UHF	SS	367.25	HYPER	SS	366.00	SS	367.25
56	56	725	723.25	UHF	TT	373.25	HYPER	TT	372.00	TT	373.25
57	57	731	729.25	UHF	UU	379.25	HYPER	UU	378.00	UU	379.25
58	58	737	735.25	UHF	VV	385.25	HYPER	VV	384.00	VV	385.25
59	59	743	741.25	UHF	WW	391.25	HYPER	WW	390.00	WW	391.25
60	60	749	747.25	UHF	XX	397.25	HYPER	XX	396.00	XX	397.25
61	61	755	753.25	UHF	YY	403.25	HYPER	YY	402.00	YY	403.25
62	62	761	759.25	UHF	ZZ	409.25	HYPER	ZZ	408.00	ZZ	409.25
63	63	767	765.25	UHF	AAA	415.25	HYPER	AAA	414.00	AAA	415.25
64	64	773	771.25	UHF	BBB	421.25	HYPER	BBB	420.00	BBB	421.25
65	65	779	777.25	UHF	CCC	427.25	ULTRA	CCC	426.00	CCC	427.25
66	66	785	783.25	UHF	DDD	433.25	ULTRA	DDD	432.00	DDD	433.25
67	67	791	789.25	UHF	EEE	439.25	ULTRA	EEE	438.00	EEE	439.25
68	68	797	795.25	UHF	FFF	445.25	ULTRA	FFF	444.00	FFF	445.25
69	69	803	801.25	UHF	GGG	451.25	ULTRA	GGG	450.00	GGG	451.25





## 2-2. Specification Comparison to Old Models

※ O : application, X : non-application

Model	LN**C450E1H / LN**C459E1H (26"/32")	LN**B457C6H (26"/32"/37"/40")
Design		
Display Type	LCD TV	LCD TV
Built-in Tuner	O	O
Resolution	1366 x 768	1366 x 768
LCD Panel	TFT LCD Panel 60Hz	TFT LCD Panel 60Hz
Screen Size	26"/32"	26"/32"/37"/40"
Picture ratio	16 : 9	16 : 9
Dimensions (W x H x D)	26" 25.5 x 8.8 x 17.0 inches _with stand	26" 26.37 x 8.50 x 19.49 inches _with stand
	32" 26.0 x 9.7 x 22.8 inches _with stand	32" 30.40 x 9.92 x 22.70 inches _with stand
Weight	26" 14.66 lbs _with stand	26" 18.5 lbs (set)
	32" 14.66 lbs _with stand	32" 25.1 lbs (set)
Brightness	450 cd/m <sup>2</sup>	500 cd/m <sup>2</sup>
Contrast Ratio	26" 40,000:1	26" 30,000:1
	32" 40,000:1	32" 50,000:1
Picture Enhancer	DNLe (SX1)	DNLe(Saturn4)
Equalizer	5 Band	5 band
Auto Volume Control	O	Not available
Surround Sound	Dolby Digital Plus	SRS TruSurround HD
Speaker Output	26" 5W + 5W	26" 5W + 5W
	32" 10W + 10W	32" 10W + 10W
PIP	O	X
Double Window	X	X
Caption	O	O
Entertainment Mode	X	X
Game Mode	O	O
Energy Saving	O	O
Anynet*	O	O
PMOLED CLOCK	X	O
DC POWER OUTPUT	X	O
USB2.0	MOVIE	JPEG
Pro:Idiom	450 Model : not supported 459 Model : supported	Not supported
Antenna	1(Cable/Air)	1(Cable/Air)

※ O : application, X : non-application

Model	LN**C530F1H / LN**C539F1H (37"/40"/46")	LN40B550K1H
Design		
Display Type	LCD TV	LCD TV
Built-in Tuner	O	Yes
Resolution	1920 x 1080	1920 x 1080
LCD Panel	TFT LCD Panel 60Hz	TFT LCD Panel 60Hz
Screen Size	37"/40"/46"	40"/ 52"
Picture ratio	16 : 9	16 : 9
Dimensions (W x D x H)	37" 26.0 x 9.7 x 22.8 inches _with stand	40" 38.68 X 10.04 X 26.6 inches with stand
	40" 26.0 x 9.7 x 22.8 inches _with stand	52" 49.54 X 12.01 X 33.55 inches with stand
	46" 43.4 x 10.2 x 28.9 inches _with stand	
Weight	37" 31.39 lbs _with stand	40" 39.68 lbs _with stand
	40" 38.14 lbs _with stand	52" 63.27 lbs _with stand
	46" 45.50 lbs _with stand	
Brightness	500 cd/m <sup>2</sup>	500 cd/m <sup>2</sup>
Contrast Ratio	50,000:1	70,000:1
Picture Enhacer	DNle (SX1)	DNle (Saturn4)
Equalizer	5 Band	5 band
Auto Volume Control	O	Not available
Surround Sound	Dolby Digital Plus	SRS TruSurround HD
Speaker Output	10W + 10W	10W + 10W
PIP	O	X
Double Window	X	X
Caption	O	O
Entertainment Mode	X	X
Game Mode	O	X
Energy Saving	O	O
Anynet*	O	O
PMOLED CLOCK	X	O
DC POWER OUTPUT	X	O
USB2.0	MOVIE	JPEG
Pro:Idiom	530 Model : not supported 539 Model : supported	Not supported
Antenna	1(Cable/Air)	1 (Cable/Air)

## 2-3. Accessories

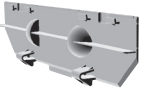
Product	Description	Code. No	Remark
	Remote Control & Batteries (AAA x 2)	BN59-01068A	Samsung Electronics Service center
	Power Cord	3903-00467	
	Cover-Bottom	32" : BN63-06389A 37"/40"/46" : BN63-06339A	
	Stand	37"/40"/46" : BN96-12799A 32" : BN96-12870C 26" : BN96-12869C	
	Screw (for the stand - M4, L16)	C530/C539 : 6003-001003 4EA V6002-001294 4EA 32" C450/C4V59 : 6003-001003 4EA 6002-001294 3EA 26" C450/C459 : 6002-001294 3EA	
	Owner's Instructions	BN68-02873A	
	Warranty Card / Registration Card / Safety Guide Manual (Not available in all locations)		
	Data cable	OCC : BN39-00865B NXTV : BN39-01011B nStreams : BN39-01110A MTI : BN39-01011C	
		DAW : BN39-00865C (only used on 450, 530 series models)	





### 3. Disassembly and Reassembly

This section of the service manual describes the disassembly and reassembly procedures for the LN40C530F1H LCD TV.



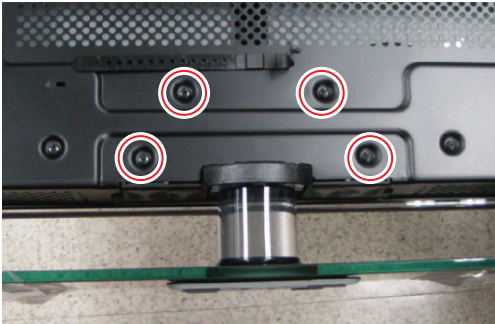

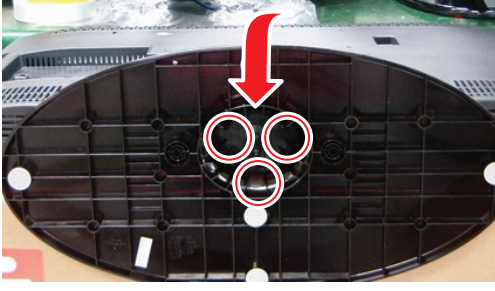
**⚠ WARNING:** This LCD TV contains electrostatically sensitive devices. Use caution when handling these components.



#### 3-1. Disassembly and Reassembly

- ⚠ Cautions:**
1. Disconnect the LCD TV from the power source before disassembly.
  2. Follow these directions carefully; never use metal instruments to pry apart the cabinet.

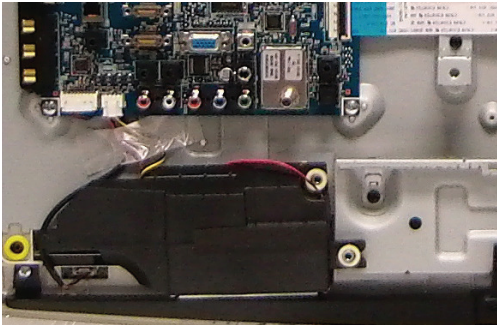
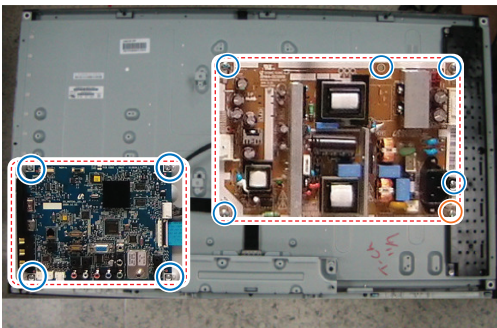
Description	Picture Description	Screws
<p>1. Place the TV face down on cushioned table. Remove 4 screws from the Stand. Remove stand.</p>	 	 6003-001003
<p>► <b>Only 26"</b> Place monitor face down on cushioned table. - Remove 3 screws from the stand. - Remove stand. - If you want to change the Main/IP board, stand removal is not required.</p>	 	 6002-001294

3. Disassembly and Reassembly

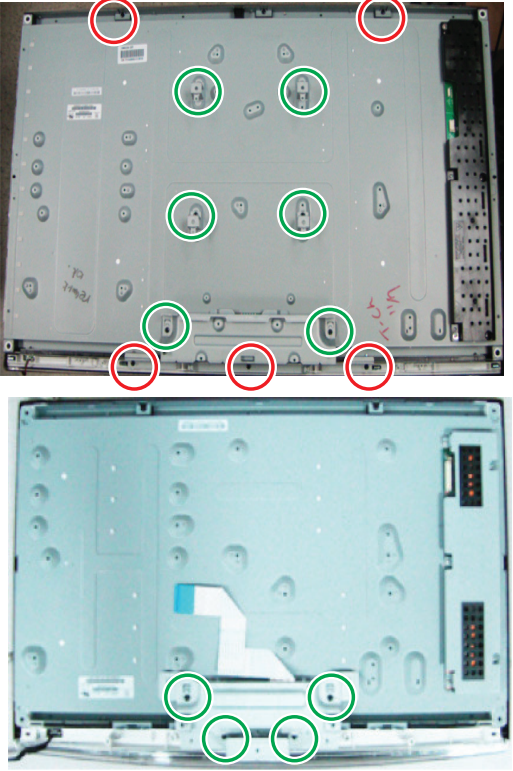
Description	Picture Description	Screws
<p>2. <b>37" C539</b> : Remove the 12 screws of rear-cover.  <b>40" C530/C539</b> : Remove the 10 screws of rear-cover.  <b>46" C539</b> : Remove the 13 screws of rear-cove.    <b>26" C450/C459</b> : Remove the 6 screws of rear-cover.  <b>32" C450/C459</b> : Remove the 8 screws of rear-cover.</p>		 6003-001003
<p>3. Lift up the rear-cover.</p>		
<p>4. Remove the left and right speaker.</p>		
<p>5. <b>26"/32"/37"</b> Remove the 4 screws of main board and 5 screws of IP board.    <b>40"/46"</b> Remove the 4 screws of main board and 7 screws of IP board.</p>		 6001-002284  6003-001439

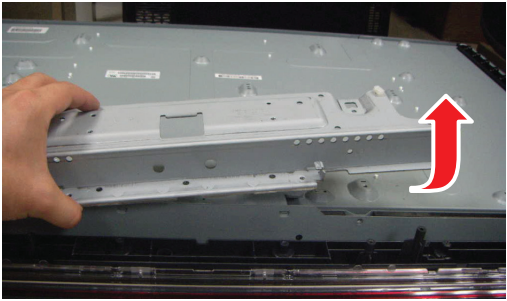
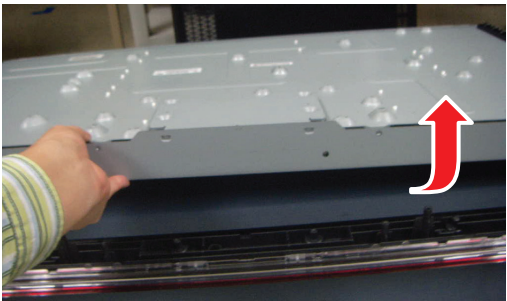
Description	Picture Description	Screws
<p>6. <b>C530/C539</b> Remove the 5 screws of bracket stand link. Remove the 4 screws of bracket wall. Remove the 2 (32" 4screws) screws of panel and front.</p> <p><b>C450/C459</b> Remove the 2screws of panel and front. Remove the 4 screws of bracket stand link.</p>		 <p>6003-000337</p>  <p>6003-001003</p>
<p>7. Lift up the stand link.</p>		
<p>8. Lift up the panel.</p>		

※ Reassembly procedures are in the reverse order of disassembly procedures.

**Screw Size**

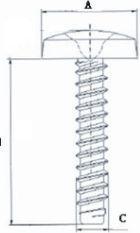
Code No.	A (mm)	B (mm)	C (mm)	Q'ty	
6001-002284	8.3±0.5	8.0±0.6	3.83~3.98	8(26"/32"/37"), 10(40"/46")	
6003-000337	7.3~8.3	9.2~10.0	3.73~3.83	4(26"), 8(32"), 6(37"/40"/46")	
6003-001439	8.3±0.4	8.0±0.4	3.85~3.93	1(ALL)	
6003-001003	7.80~8.30	11.20~12.00	3.81~3.91	10(26") 12(32") 17(37"), 15(40"), 18(46")	

## 4. Troubleshooting

### 4-1. Troubleshooting

1. Check the various cable connections first.
  - Check to see if there is a burnt or damaged cable.
  - Check to see if there is a disconnected or loose cable connection.
  - Check to see if the cables are connected according to the connection diagram.
2. Check the power input to the Main Board.

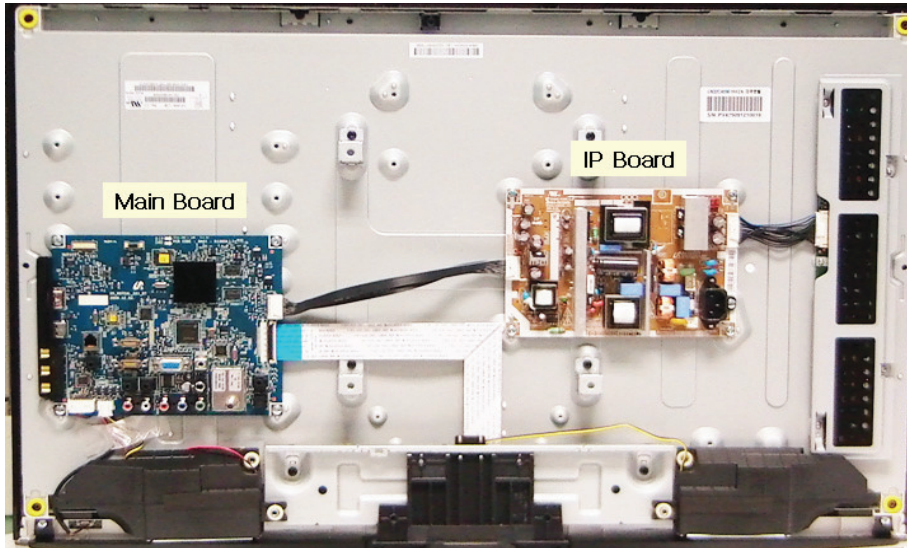

### 4-1-2. No Power

Symptom	<ul style="list-style-type: none"> <li>- The LEDs on the front panel do not work when connecting the power cord.</li> <li>- The SMPS relay does not work when connecting the power cord.</li> <li>- The units appears to be dead.</li> </ul>
Major checkpoints	<p>The IP relay or the LEDs on the front panel does not work when connecting the power cord if the cables are improperly connected or the Main Board or SMPS is not functioning.</p> <p>In this case, check the following:</p> <ul style="list-style-type: none"> <li>- Check the internal cable connection status inside the unit.</li> <li>- Check the fuses of each part.</li> <li>- Check the output voltage of SMPS.</li> <li>- Replace the Main Board.</li> </ul>

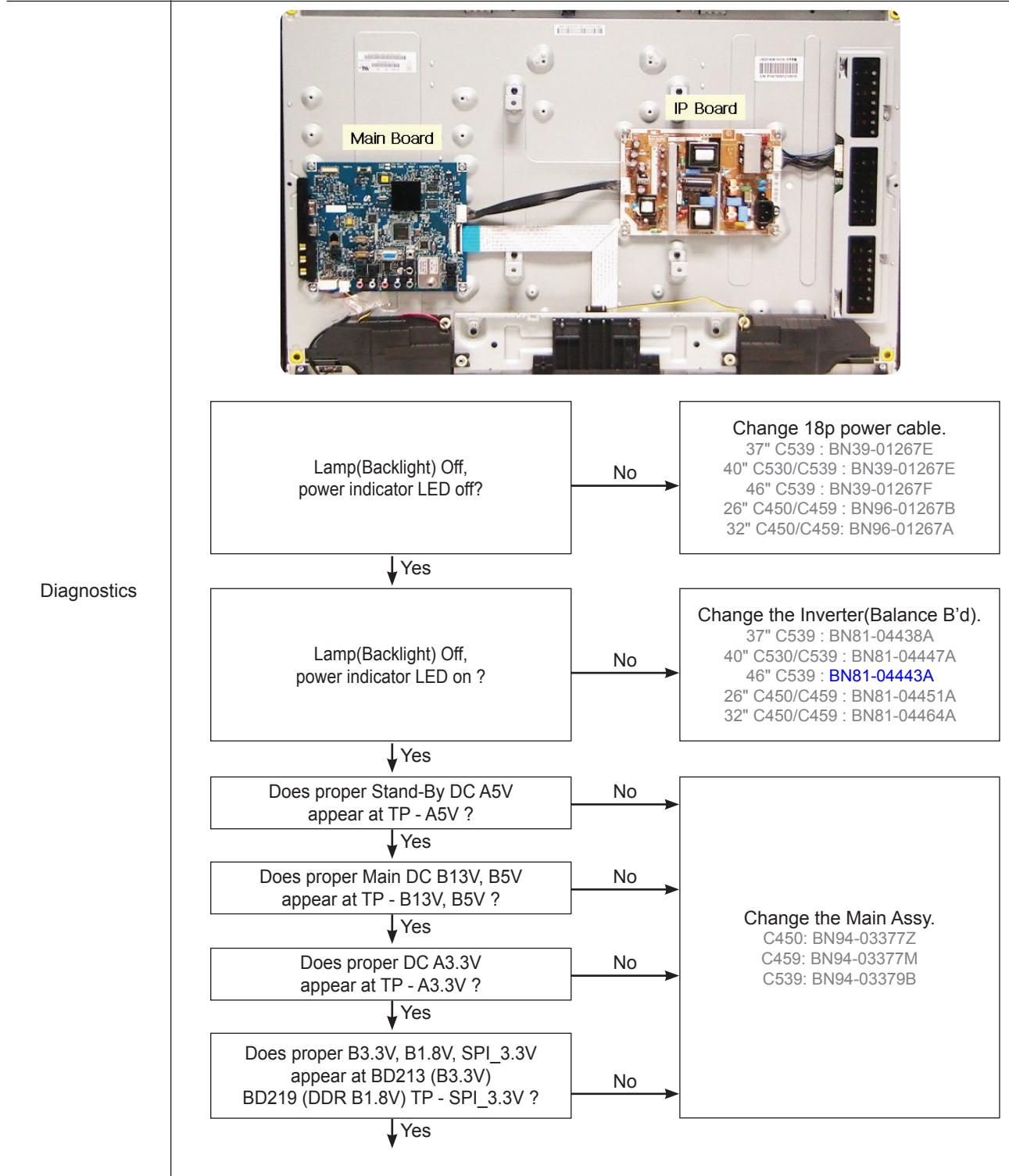
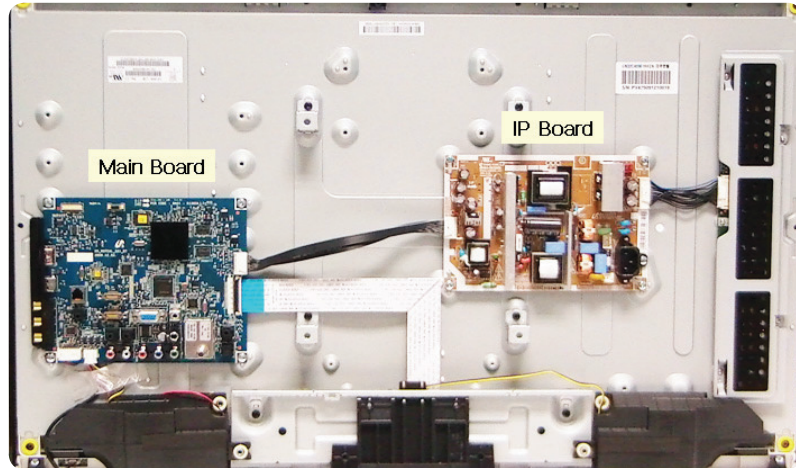

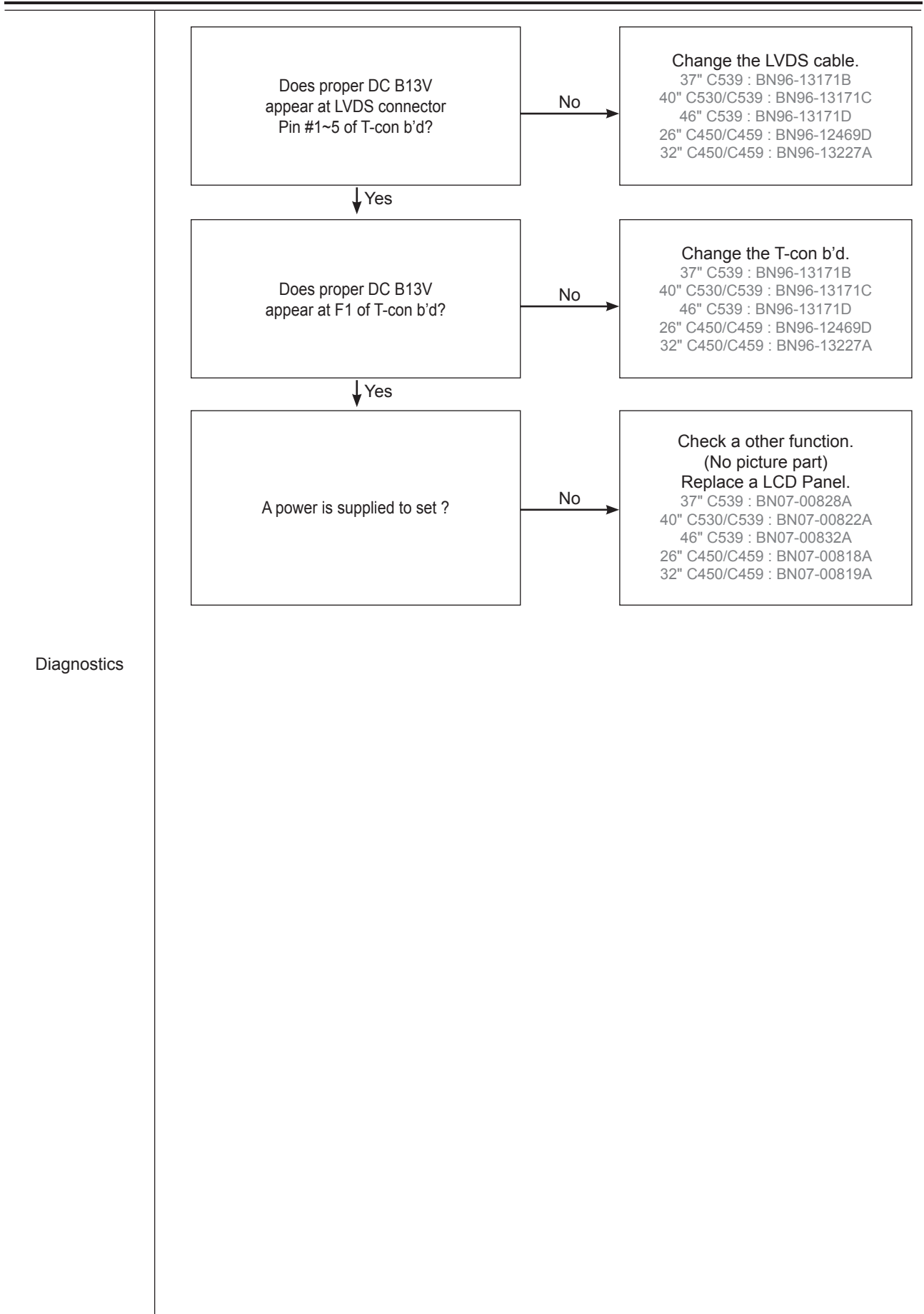

Caution

Make sure to disconnect the power before working on the IP board.

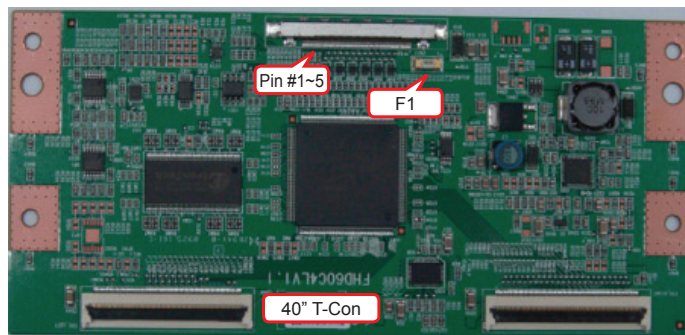
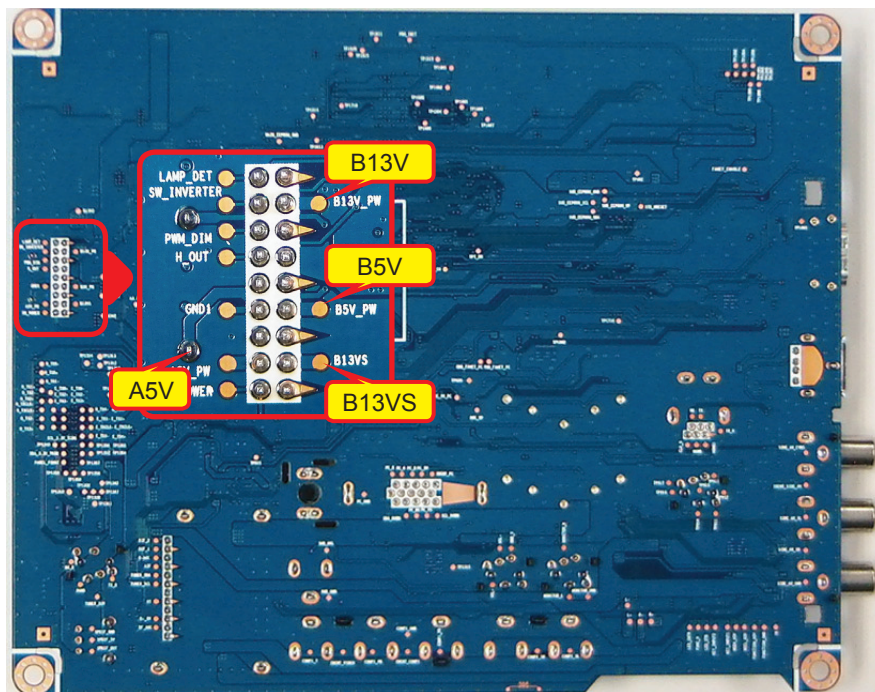
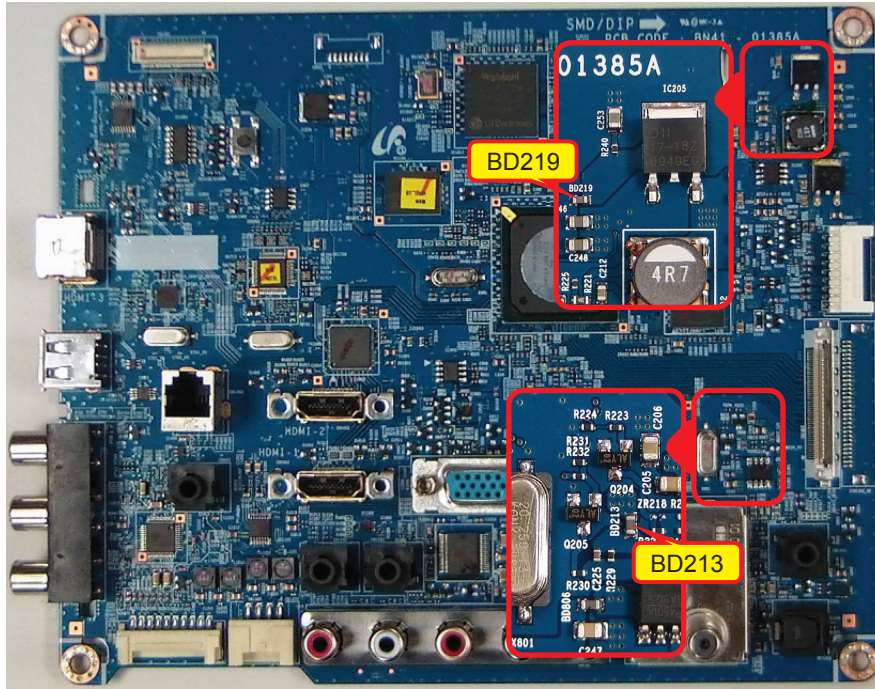

### 4-1-3. No Video (Analog PC signal)

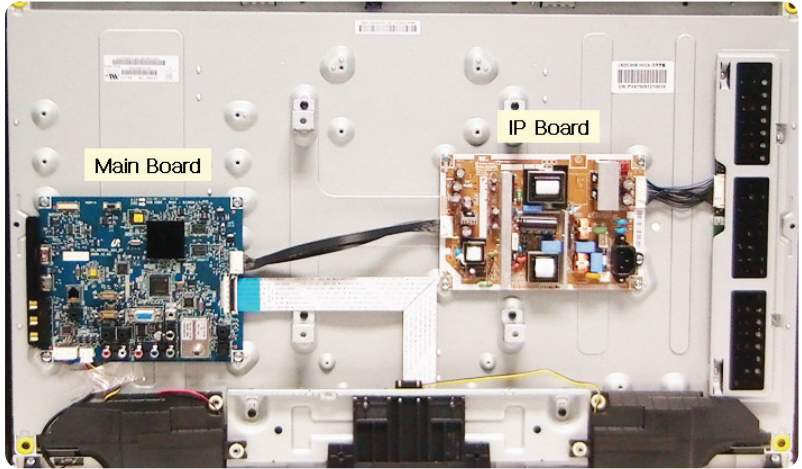
Symptom	<ul style="list-style-type: none"> <li>- Audio is normal but no picture is displayed on the screen.</li> </ul>
Major checkpoints	<ul style="list-style-type: none"> <li>- Check the PC source</li> <li>- Check the Arsenal, Check the Chelsea.</li> <li>- This may happen when the LVDS cable connecting the Main Board and the Panel is disconnected.</li> </ul>
Diagnostics	 <p>The image shows the internal components of the device. The Main Board is on the left, and the IP Board is on the right. They are connected by a ribbon cable. The device is housed in a white plastic casing.</p> <pre> graph TD     Q1[Power indicator LED is off. Lamp(Backlight) on, no video ?] -- No --&gt; A1[Check a set in the 'Stand-by mode'. or 'DPMS mode'.]     Q1 -- Yes --&gt; Q2[Check the PC source and check the connection of D-SUB ?]     Q2 -- No --&gt; A2[Input the analog PC signal properly.]     Q2 -- Yes --&gt; Q3[1 Does the signal appear at TP - PC_R, PC_G, PC_B, PC_HS, PC_VS (R, G, B, H, V) ?]     Q3 -- No --&gt; A3[Check CN901, PC cable. Change the Main Assy. C450: BN94-03377Z C459: BN94-03377M C539: BN94-03379B]     Q3 -- Yes --&gt; Q4[2 Does the digital data appear at TP-E_TXCLK+, E_TXCLK-, O_TXCLK+, O_TXCLK- ?]     Q4 -- No --&gt; A4[Check IC301 (SX1) Change the Main Assy. C450: BN94-03377Z C459: BN94-03377M C539: BN94-03379B]     Q4 -- Yes --&gt; Q5[Check the LVDS cable? Check the T-Con B'd? Replace the LCD panel?]     Q5 -- No --&gt; A5[Please, Contact Tech support.]   </pre> <p>Power indicator LED is off. Lamp(Backlight) on, no video ?</p> <p>No → Check a set in the 'Stand-by mode'. or 'DPMS mode'.</p> <p>Yes → Check the PC source and check the connection of D-SUB ?</p> <p>No → Input the analog PC signal properly.</p> <p>Yes → 1 Does the signal appear at TP - PC_R, PC_G, PC_B, PC_HS, PC_VS (R, G, B, H, V) ?</p> <p>No → Check CN901, PC cable. Change the Main Assy. C450: BN94-03377Z C459: BN94-03377M C539: BN94-03379B</p> <p>Yes → 2 Does the digital data appear at TP-E_TXCLK+, E_TXCLK-, O_TXCLK+, O_TXCLK- ?</p> <p>No → Check IC301 (SX1) Change the Main Assy. C450: BN94-03377Z C459: BN94-03377M C539: BN94-03379B</p> <p>Yes → Check the LVDS cable? Check the T-Con B'd? Replace the LCD panel?</p> <p>No → Please, Contact Tech support.</p>
Caution	Make sure to disconnect the power before working on the IP board.

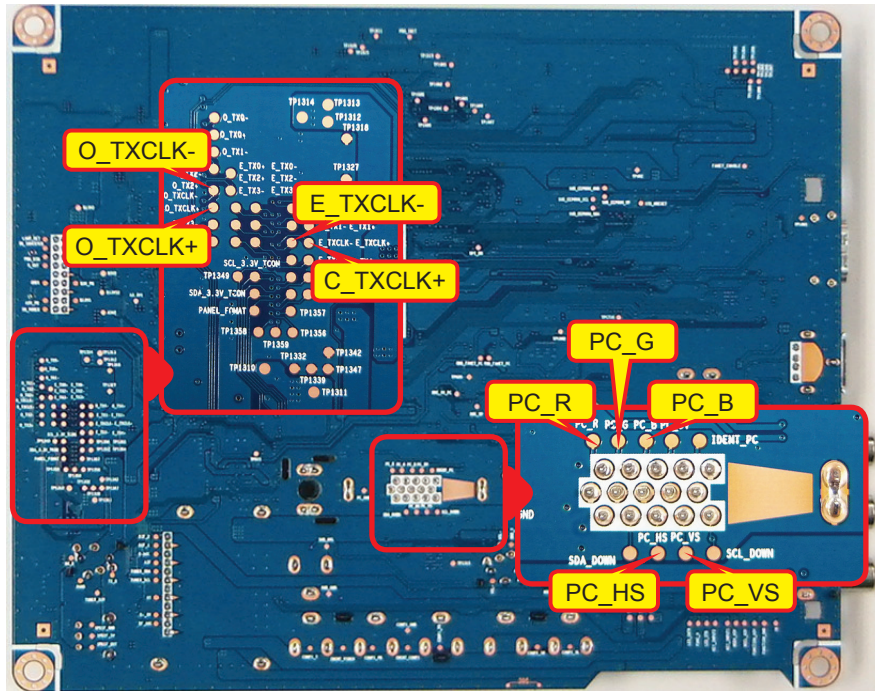

# WAVEFORMS

## 1 PC input (V-sink , H-sink , R/G/B)

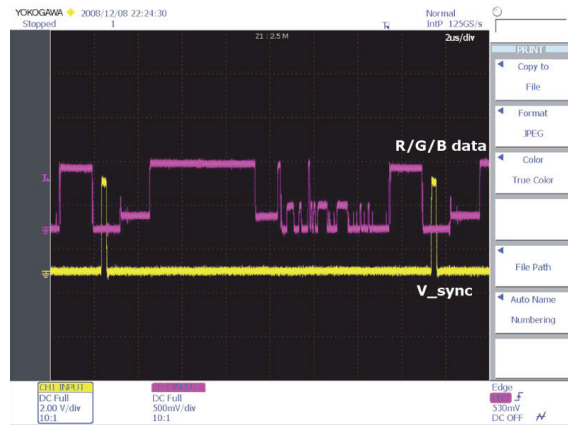
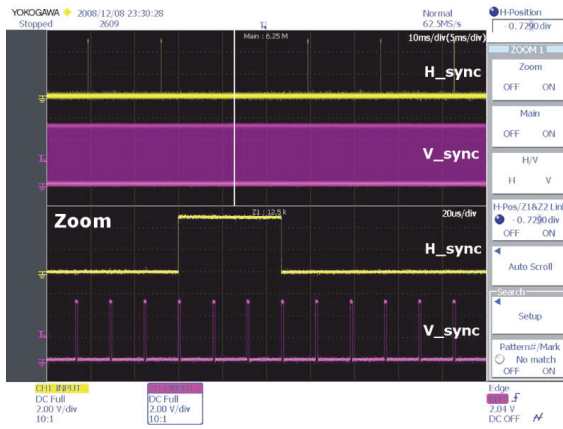

## 2 LVDS output

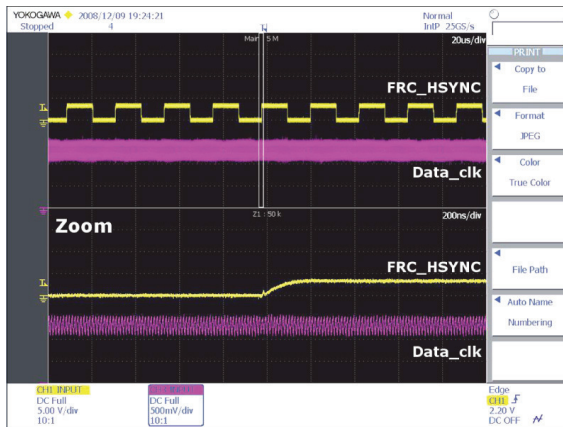

### 4-1-4. No video (HDMI1, 2, 3 - Digital signal)

Symptom	- Audio is normal but no picture is displayed on the screen.
Major checkpoints	<ul style="list-style-type: none"> <li>- Check the HDMI source.</li> <li>- Check the HDMI switch, Check the Chelsea.</li> <li>- This may happen when the LVDS cable connecting the Main Board and the Panel is disconnected.</li> </ul>

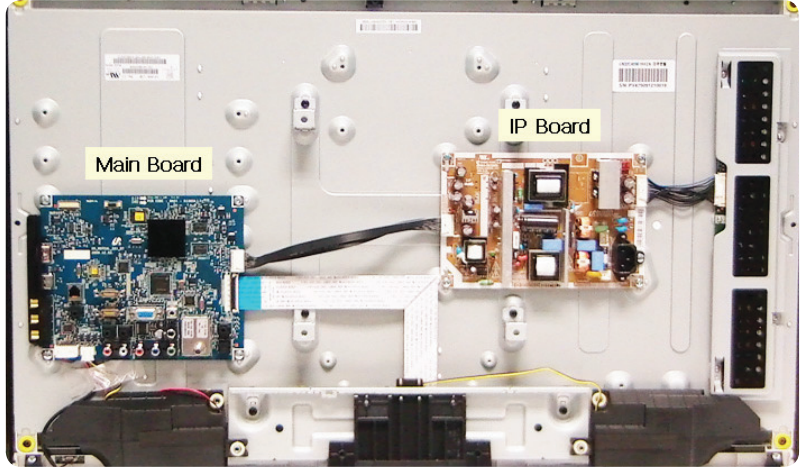

**Diagnostics**

```

graph TD
    Q1[Power indicator LED is off.  
Lamp(Backlight) on, no video ?] -- No --> A1[Check a set in the 'Stand-by mode'.']
    Q1 -- Yes --> Q2[Check the HDMI source and  
check the connection of HDMI cable ?]
    Q2 -- No --> A2[Input the HDMI signal properly.]
    Q2 -- Yes --> Q3[Does the signal appear at  
CN1002 (Pin#12, #7) (HDMI1) CN1003  
(Pin#12, #7) (HDMI2) CN1004 (Pin#12, #7)  
(HDMI3) CN1001 (Pin#12, #7) (HDMI4)  
(HDMI RX_Clk , RX_Data) ?]
    Q3 -- No --> A3[Check CN1001,CN1002, CN1003, CN1004.  
Check HDMI cable. Change the Main Assy.  
C450: BN94-03377Z  
C459: BN94-03377M  
C539: BN94-03379B]
    Q3 -- Yes --> Q4[Does the digital data appear at  
TP-E_TXCLK+, E_TXCLK-,  
O_TXCLK+, O_TXCLK- ?]
    Q4 -- No --> A4[Check IC301 (SX1)  
Change the Main Assy.  
C450: BN94-03377Z  
C459: BN94-03377M  
C539: BN94-03379B]
    Q4 -- Yes --> Q5[Check the LVDS cable?  
Check the T-Con B'd?  
Replace the LCD panel?]
    Q5 -- No --> A5[Please, Contact Tech support.]
    
```

Caution	Make sure to disconnect the power before working on the IP board.
---------	---

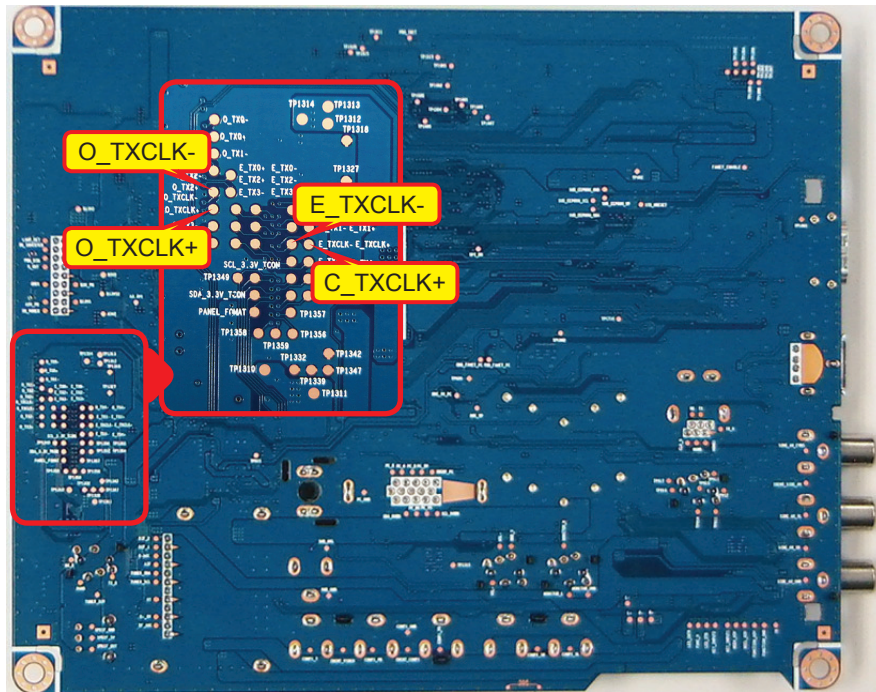
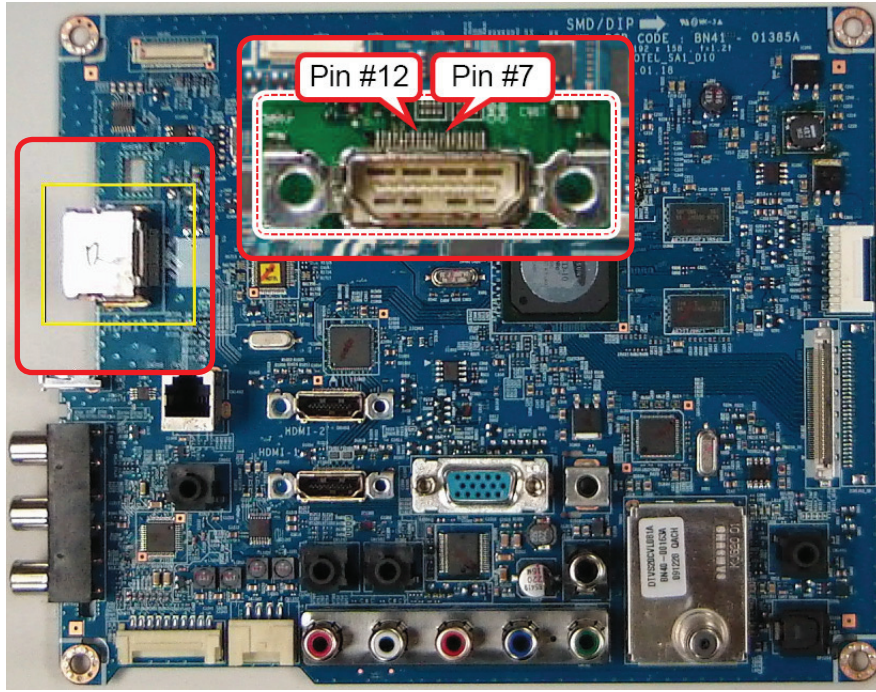

## ■ WAVEFORMS

3

HDMI input (RX\_Data, RX\_Clk)

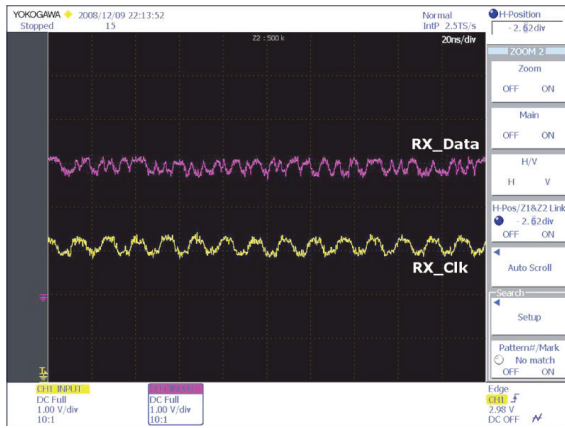

2

LVDS output

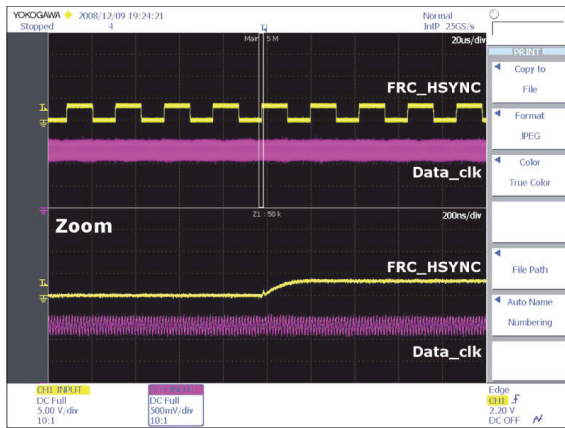

## 4-1-5. No Video (Tuner\_CVBS)

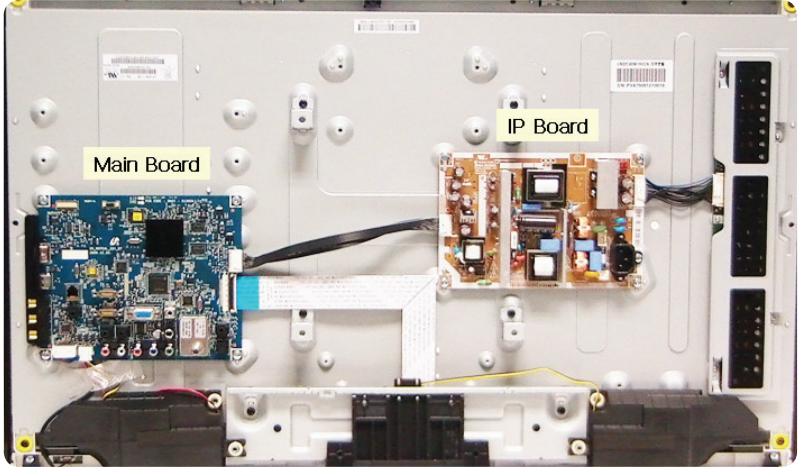
Symptom	<ul style="list-style-type: none"> <li>- Audio is normal but no picture is displayed on the screen.</li> </ul>
Major checkpoints	<ul style="list-style-type: none"> <li>- Check the Tuner CVBS source.</li> <li>- Check the Tuner, Check the Chelsea.</li> <li>- This may happen when the LVDS cable connecting the Main Board and the Panel is disconnected.</li> </ul>
Diagnostics	 <pre> graph TD     Q1[Power indicator LED is off. Lamp(Backlight) on, no video ?] -- No --&gt; A1[Check a set in the 'Stand-by mode']     Q1 -- Yes --&gt; Q2[Check the RF source and check the connection of RF cable ?]     Q2 -- No --&gt; A2[Input the RF source properly.]     Q2 -- Yes --&gt; Q3[Does the DC B5V_TU_PW, TU33V_PW appear at #3, #5 Pin of Tuner ?]     Q3 -- No --&gt; A3[Change the Main Assy. C450: BN94-03377Z C459: BN94-03377M C539: BN94-03379B]     Q3 -- Yes --&gt; Q4[Does the digital data appear at TP-E_TXCLK+, E_TXCLK-, O_TXCLK+, O_TXCLK- ?]     Q4 -- No --&gt; A4[Check IC301 (SX1) Change the Main Assy. C450: BN94-03377Z C459: BN94-03377M C539: BN94-03379B]     Q4 -- Yes --&gt; Q5[Check the LVDS cable? Check the T-Con B'd? Replace the LCD panel?]     Q5 -- No --&gt; A5[Please, Contact Tech support.]   </pre> <p>Power indicator LED is off. Lamp(Backlight) on, no video ?</p> <p>No → Check a set in the 'Stand-by mode'</p> <p>Yes → Check the RF source and check the connection of RF cable ?</p> <p>No → Input the RF source properly.</p> <p>Yes → Does the DC B5V_TU_PW, TU33V_PW appear at #3, #5 Pin of Tuner ?</p> <p>No → Change the Main Assy. C450: BN94-03377Z C459: BN94-03377M C539: BN94-03379B</p> <p>Yes → Does the digital data appear at TP-E_TXCLK+, E_TXCLK-, O_TXCLK+, O_TXCLK- ?</p> <p>No → Check IC301 (SX1) Change the Main Assy. C450: BN94-03377Z C459: BN94-03377M C539: BN94-03379B</p> <p>Yes → Check the LVDS cable? Check the T-Con B'd? Replace the LCD panel?</p> <p>No → Please, Contact Tech support.</p>
Caution	Make sure to disconnect the power before working on the IP board.



## ■ WAVEFORMS

### 2 LVDS output

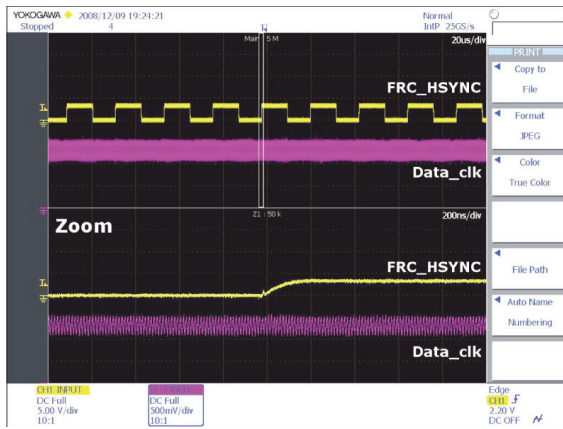

### 4-1-6. No Video (Tuner DTV)

Symptom	- Audio is normal but no picture is displayed on the screen.
Major checkpoints	<ul style="list-style-type: none"> <li>- Check the DTV source.</li> <li>- Check the Tuner, Check the Chelsea.</li> <li>- This may happen when the LVDS cable connecting the Main Board and the Panel is disconnected.</li> </ul>

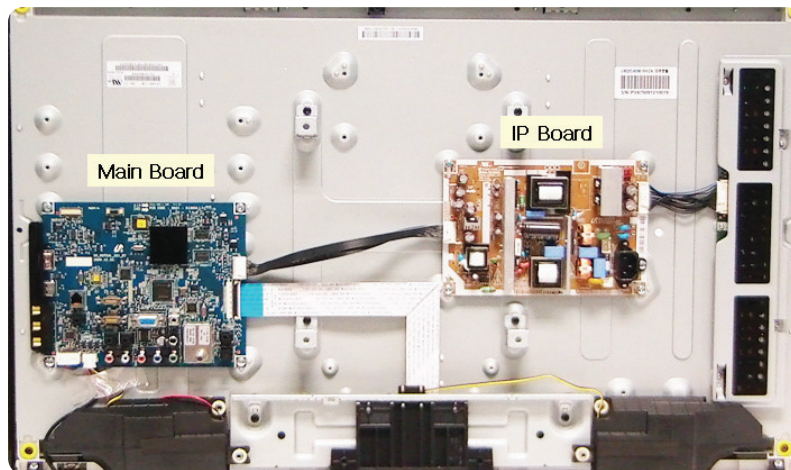

Diagnostics

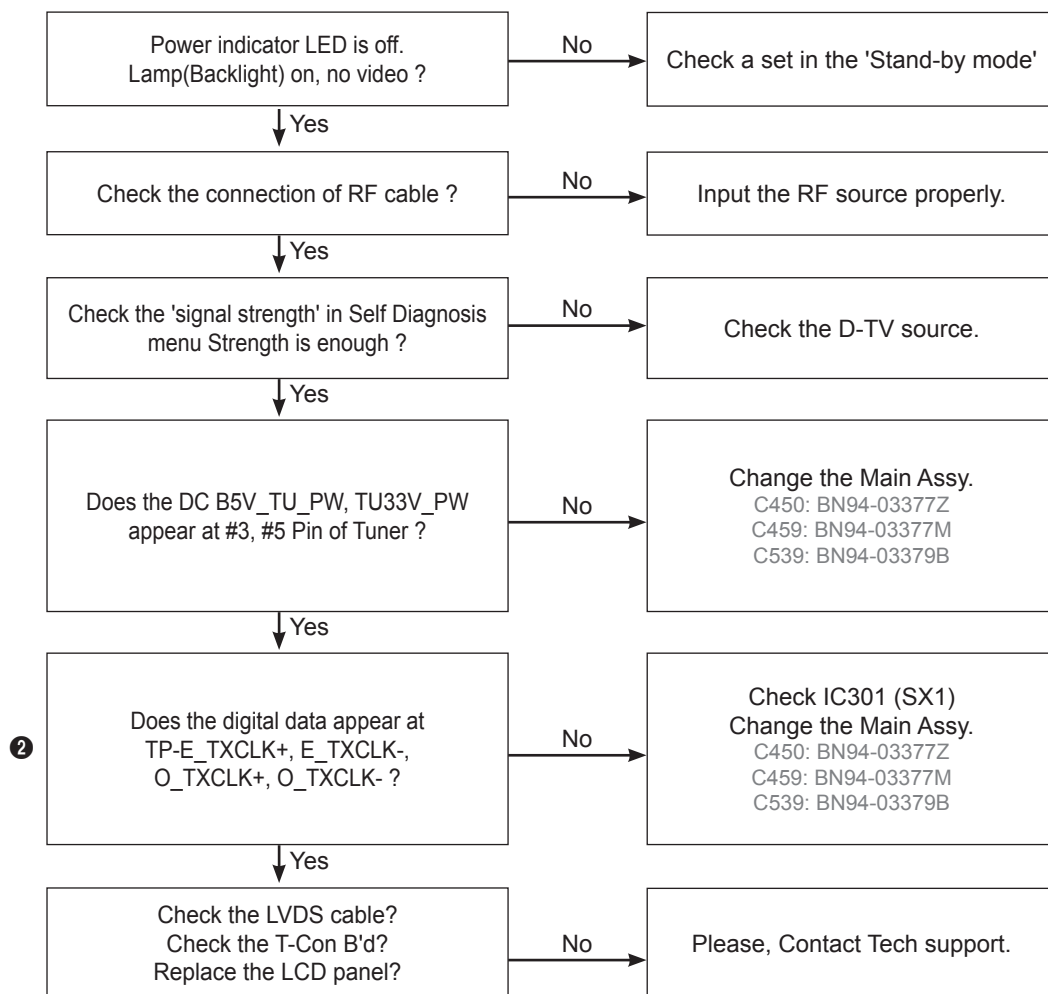

Caution	Make sure to disconnect the power before working on the IP board.
---------	---



## ■ WAVEFORMS

2

LVDS output

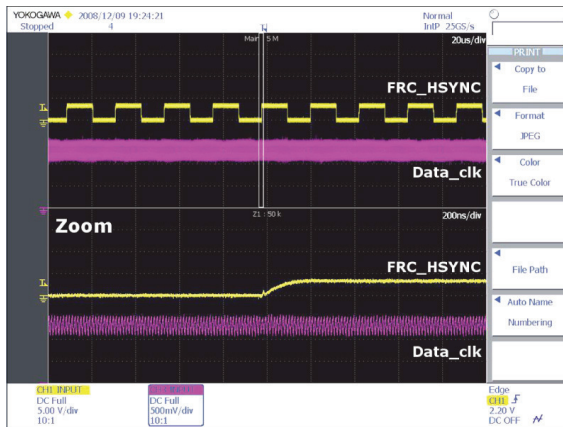

## 4-1-7. No Video (Video CVBS)

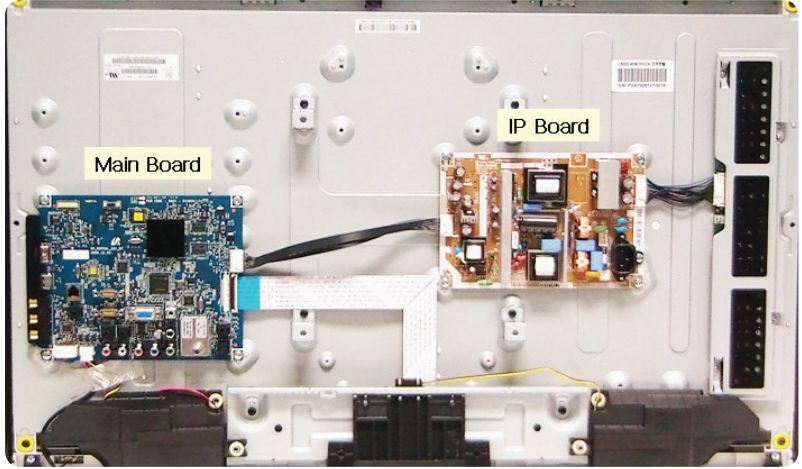
Symptom	<ul style="list-style-type: none"> <li>- Audio is normal but no picture is displayed on the screen.</li> </ul>
Major checkpoints	<ul style="list-style-type: none"> <li>- Check the Video CVBS source</li> <li>- Check the Chelsea.</li> <li>- This may happen when the LVDS cable connecting the Main Board and the Panel is disconnected.</li> </ul>
Diagnostics	 <pre> graph TD     Q1[Power indicator LED is off. Lamp(Backlight) on, no video ?] -- No --&gt; A1[Check a set in the 'Stand-by mode']     Q1 -- Yes --&gt; Q2[Check the video source and check the connection of video cable?]     Q2 -- No --&gt; A2[Input the video source properly.]     Q2 -- Yes --&gt; Q3[4 Does the CVBS data appear at TP-COMP1_Y TP-SIDE_AV_CVBS ?]     Q3 -- No --&gt; A3[Check CN701, CN704. Change the Main Assy. C450: BN94-03377Z C459: BN94-03377M C539: BN94-03379B]     Q3 -- Yes --&gt; Q4[2 Does the digital data appear at TP-E_TXCLK+, E_TXCLK-, O_TXCLK+, O_TXCLK- ?]     Q4 -- No --&gt; A4[Check IC301 (SX1) Change the Main Assy. C450: BN94-03377Z C459: BN94-03377M C539: BN94-03379B]     Q4 -- Yes --&gt; Q5[Check the LVDS cable? Check the T-Con B'd? Replace the LCD panel?]     Q5 -- No --&gt; A5[Please, Contact Tech support.]   </pre> <p>Power indicator LED is off. Lamp(Backlight) on, no video ?</p> <p>No → Check a set in the 'Stand-by mode'</p> <p>Yes → Check the video source and check the connection of video cable?</p> <p>No → Input the video source properly.</p> <p>Yes → ④ Does the CVBS data appear at TP-COMP1_Y TP-SIDE_AV_CVBS ?</p> <p>No → Check CN701, CN704. Change the Main Assy. C450: BN94-03377Z C459: BN94-03377M C539: BN94-03379B</p> <p>Yes → ② Does the digital data appear at TP-E_TXCLK+, E_TXCLK-, O_TXCLK+, O_TXCLK- ?</p> <p>No → Check IC301 (SX1) Change the Main Assy. C450: BN94-03377Z C459: BN94-03377M C539: BN94-03379B</p> <p>Yes → Check the LVDS cable? Check the T-Con B'd? Replace the LCD panel?</p> <p>No → Please, Contact Tech support.</p>
Caution	Make sure to disconnect the power before working on the IP board.

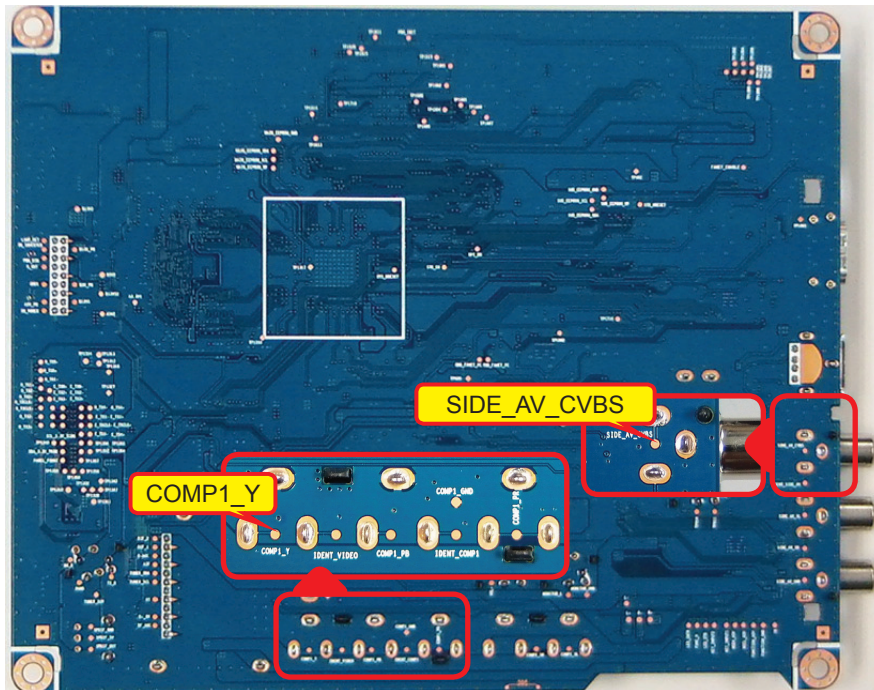
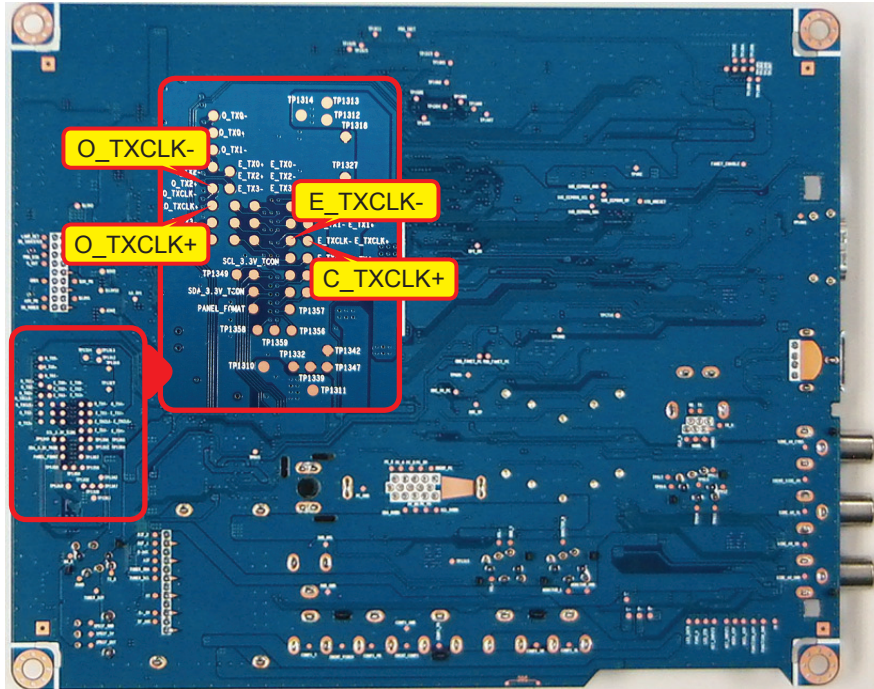

## ■ WAVEFORMS

### 4 CVBS OUT (Grey Bar)

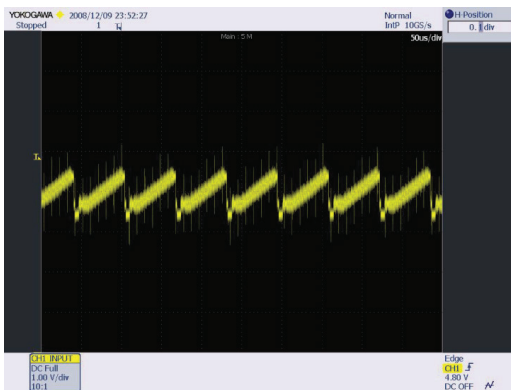

### 2 LVDS output

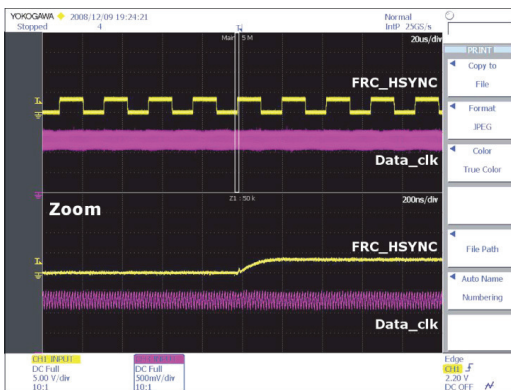

### 4-1-8. No Video (Component)

Symptom	- Audio is normal but no picture is displayed on the screen.
Major checkpoints	<ul style="list-style-type: none"> <li>- Check the Component source</li> <li>- Check the chelsea.</li> <li>- This may happen when the LVDS cable connecting the Main Board and the Panel is disconnected.</li> </ul>

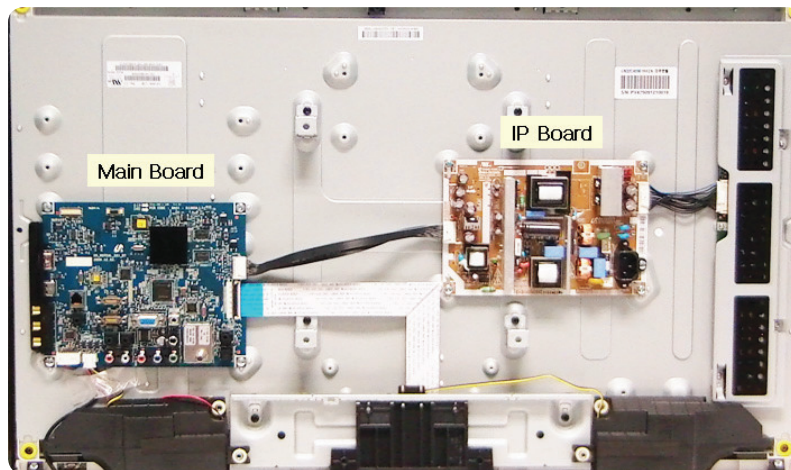

Diagnostics

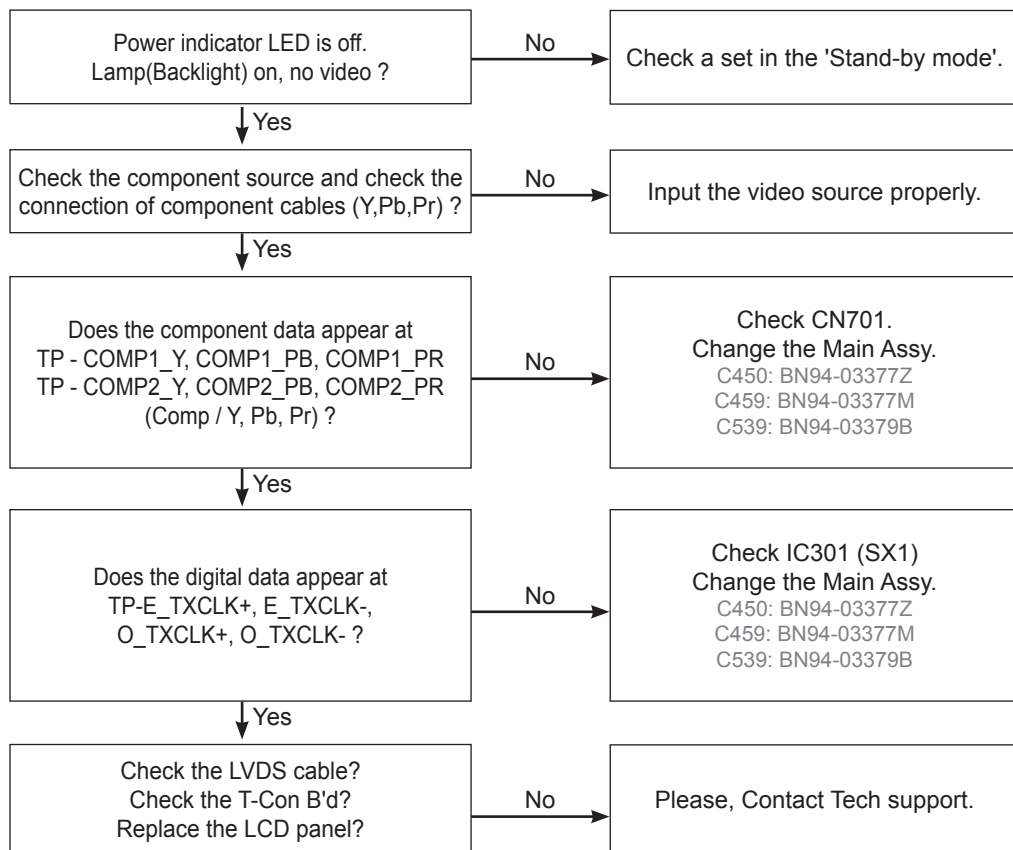

Caution	Make sure to disconnect the power before working on the IP board.
---------	---

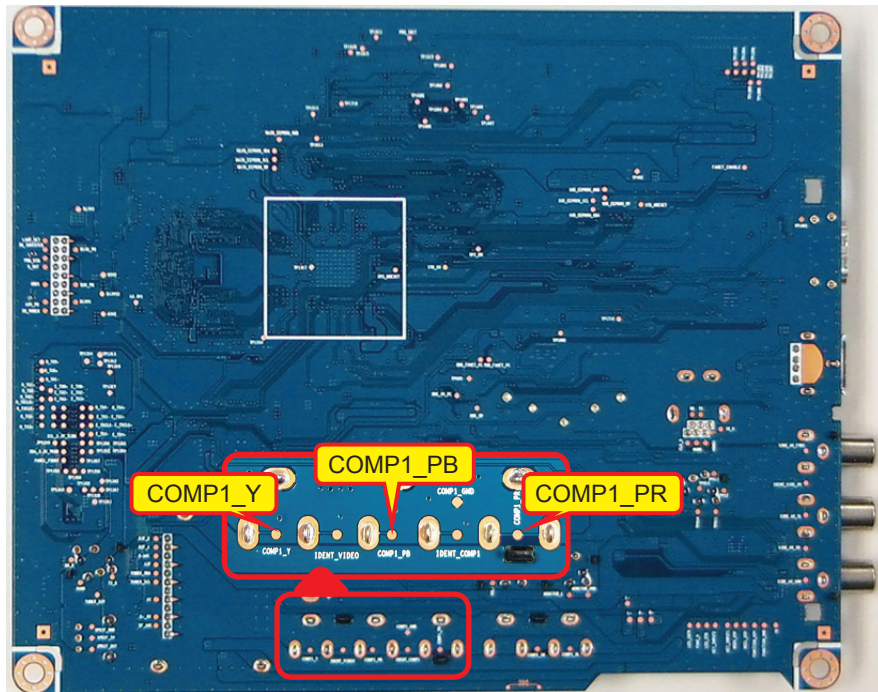
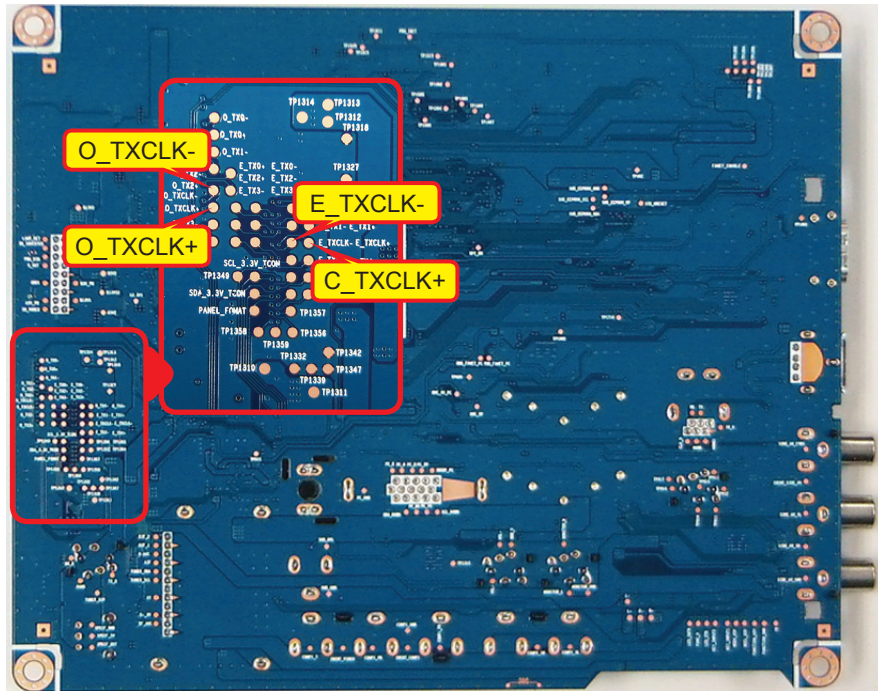

## WAVEFORMS

### 5 Component\_Y (Gray scale) / Pb / Pr (Color bar)



### 2 LVDS output

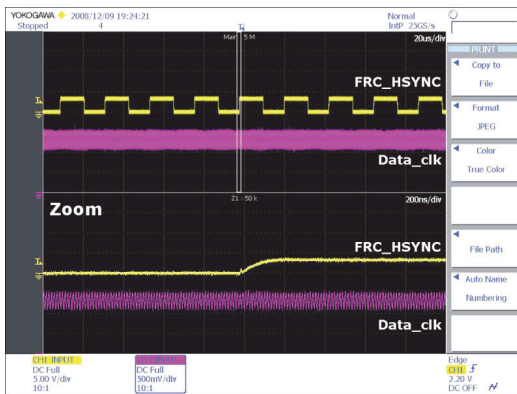

## 4-1-9. No Sound

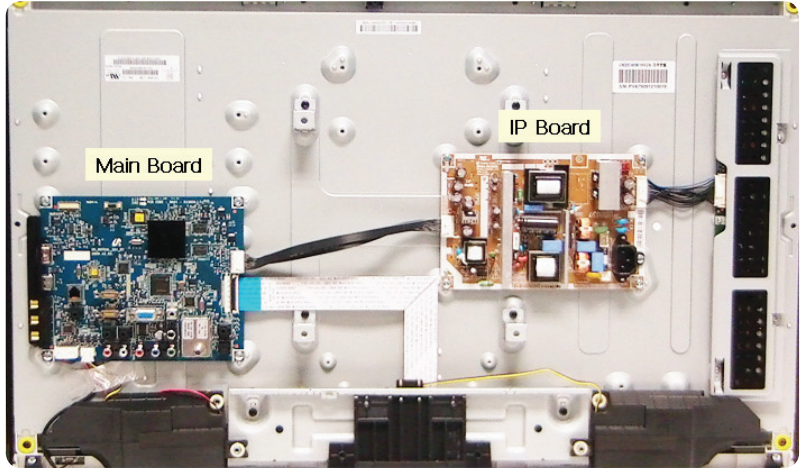
Symptom	- Video is normal but there is no sound..
Major checkpoints	<ul style="list-style-type: none"> <li>- When the speaker connectors are disconnected or damaged.</li> <li>- When the sound processing part of the Main Board is not functioning.</li> <li>- Speaker defect..</li> </ul>
Diagnostics	 <p>The image shows the internal components of the device. The Main Board is on the left, and the IP Board is on the right. Various connectors and components are visible on both boards.</p> <pre> graph TD     Q1[Check the source and check the connection of sound cable (Comp/PC/DVI to HDMI) ?] -- No --&gt; A1[Check a set in the 'Stand-by mode'.]     Q1 -- Yes --&gt; Q2[Check the component source and check the connection of component cables (Y,Pb,Pr) ?]     Q2 -- No --&gt; A2[Input the video source properly.]     Q2 -- Yes --&gt; Q3[Does the sound data appear at TP - COMP1_SL, COMP1_SR (AV1, COMP1) TP - COMP2_SL, COMP2_SR (Comp2) TP - SIDE_AV_SL, SIDE_AV_SR(AV2) TP - 914, 915 (PC/DVI) ?]     Q3 -- No --&gt; A3[Check CN701, CN704, CN902. Change the Main Assy. C450: BN94-03377Z C459: BN94-03377M C539: BN94-03379B]     Q3 -- Yes --&gt; Q4[Does the DC B3.3V, B12V appear at TP - B3.3V, B12V?]     Q4 -- No --&gt; A4[Change the Main Assy. C450: BN94-03377Z C459: BN94-03377M C539: BN94-03379B]     Q4 -- Yes --&gt; Q5[Does the sound data appear at - L-, L+, R-, R+ ?]     Q5 -- No --&gt; A5[Check IC201 (Saturn4). Check IC904 (Sound AMP). Change the Main Assy. C450: BN94-03377Z C459: BN94-03377M C539: BN94-03379B]     Q5 -- Yes --&gt; Q6[Replace speaker? BN96-12871A]     Q6 -- No --&gt; A6[Please, Contact Tech support.]   </pre> <p>7</p>
Caution	Make sure to disconnect the power before working on the IP board.

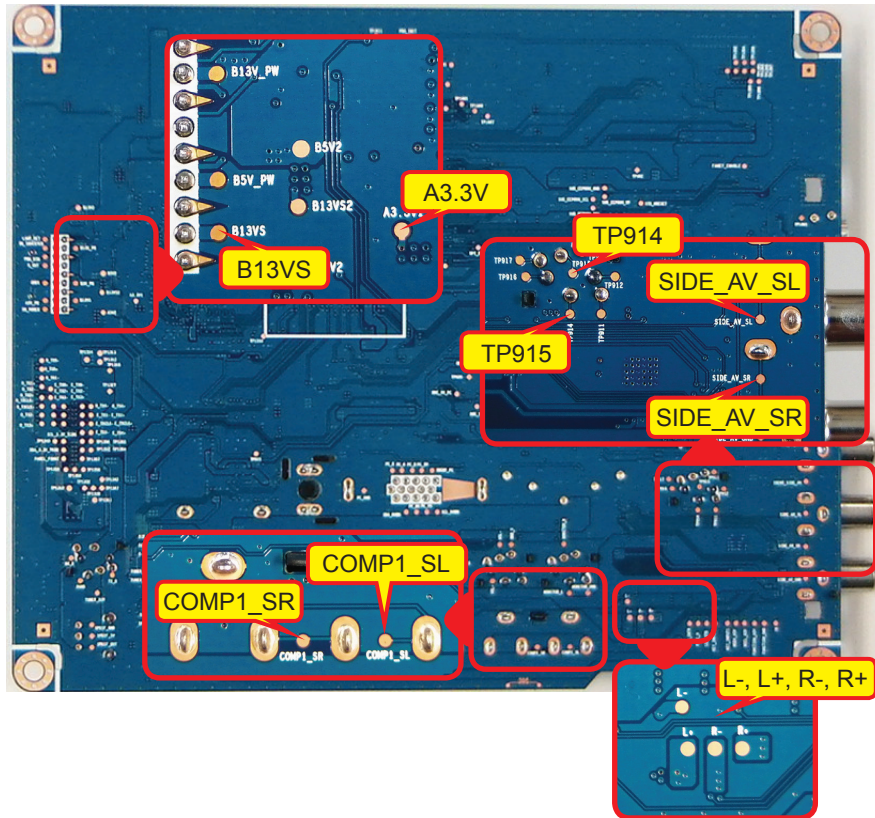

## WAVEFORMS

### 7 Speaker out

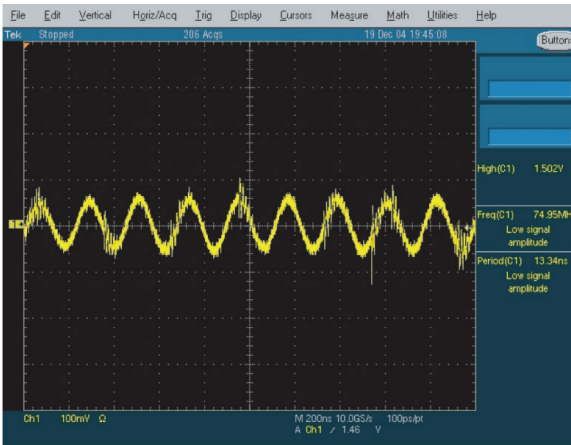

### 4-1-10. No Video and No Sound

(Only 459, 539 Model : DTV of channel encrypted by Pro:Idiom)

Symptom	<ul style="list-style-type: none"> <li>- The video and sound of the channel encrypted by Pro:Idiom is not played in the model to support Pro:Idiom-decryption.</li> <li>- The only banner, "weak signal or scrambled channel" is displayed without any video and sound.</li> </ul>
Major checkpoints	<p>The problem is why the circuit block of Pro:Idiom IC has some problem or signal of the encrypted channel is weak.</p> <ul style="list-style-type: none"> <li>- Check the following below.</li> <li>- Check VCC and Clock of Pro:Idiom IC.</li> <li>- Check the signal strength of the encrypted channel.</li> </ul>

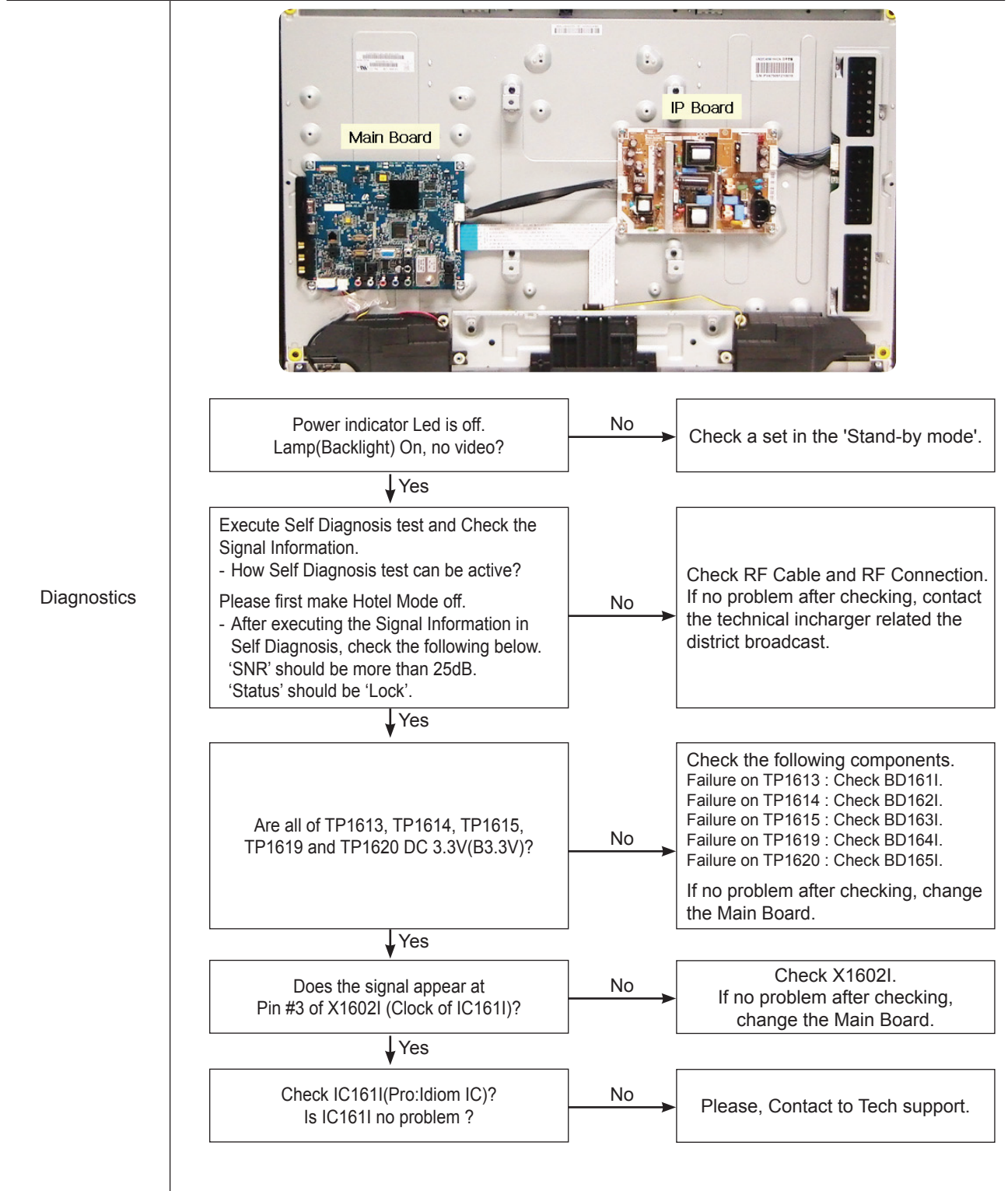

Caution	Make sure to disconnect the power before working on the IP board.
---------	---

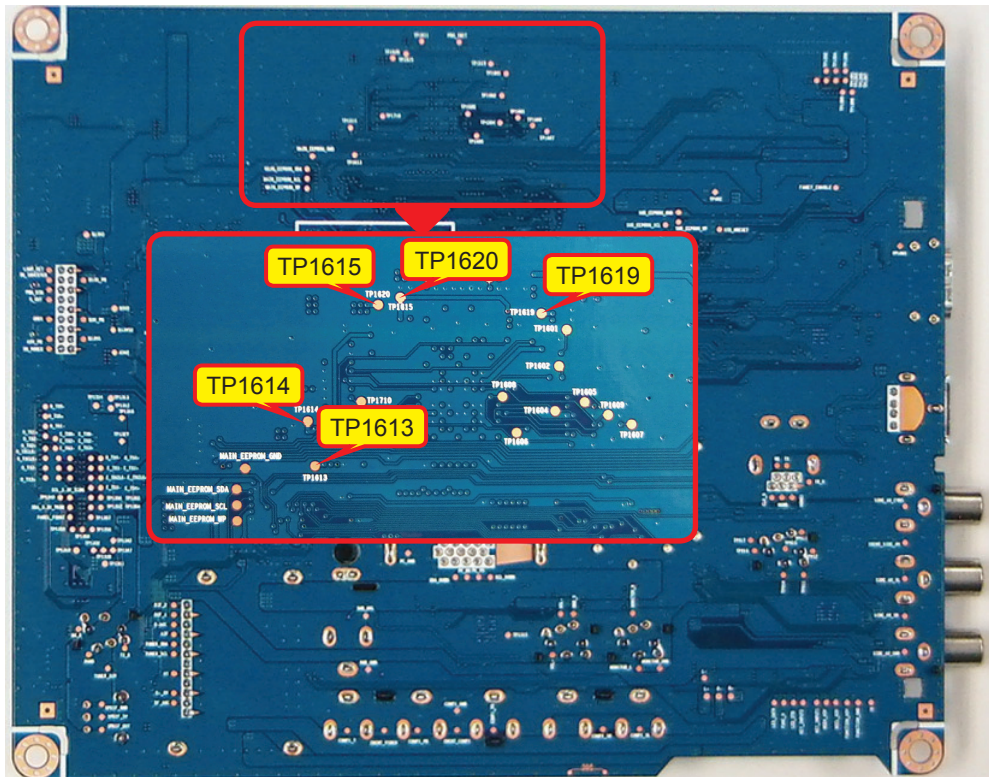
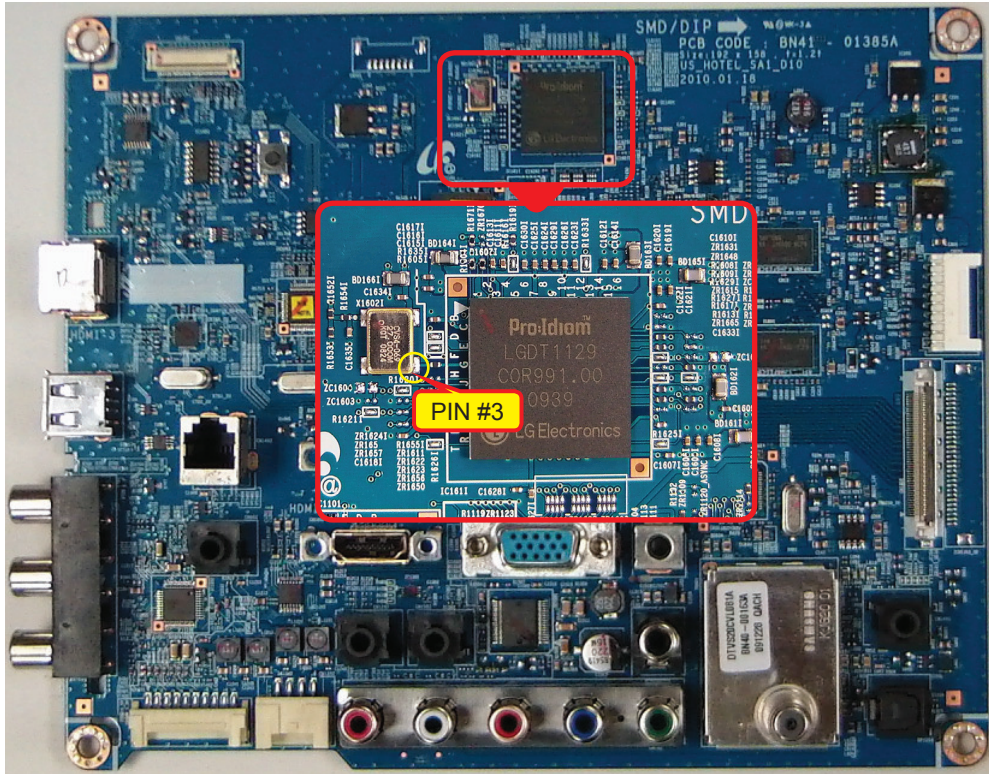

## ■ WAVEFORMS

10

Clock of IC1611

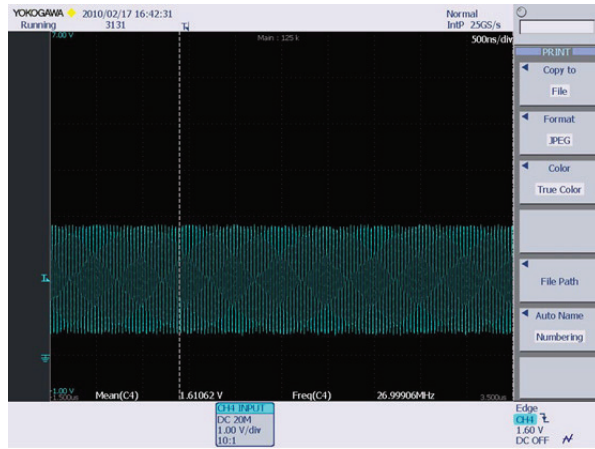

## 4-2. Alignments and Adjustments

### 4-2-1. General Alignment Instruction

1. Usually, a color LCD-TV needs only slight touch-up adjustment upon installation. Check the basic characteristics such as height, horizontal and vertical sync.
2. Use the specified test equipment or its equivalent.
3. Correct impedance matching is essential.
4. Avoid overload. Excessive signal from a sweep generator might overload the front-end of the TV. When inserting signal markers, do not allow the marker generator to distort test result.
5. Connect the TV only to an AC power source with voltage and frequency as specified on the backcover nameplate.
6. Do not attempt to connect or disconnect any wire while the TV is turned on. Make sure that the power cord is disconnected before replacing any parts.
7. To protect against shock hazard, use an isolation transformer.

## 4-3. Factory Mode Adjustments

### 4-3-1. Entering Factory Mode

To enter 'Service Mode' Press the remote-control keys in this sequence :

- If you do not have Factory remote- control



- If you have factory remote-control



\* If you enter the Factory mode not using Factory remote controller, you can't see the two menu, 'Expert' and 'Advance'.  
 (- It is protected from normal user for security.)

Press the Power button to exit and store data in memory.

- If you fail to enter service mode, repeat steps 1 and 2 above.

Initial SERVICE MODE DISPLAY State

<b>Option</b>
Control
SVC
Expert
ADC/WB
Advanced
T-TDT5HUSC-XXX T-TDT5HUSS-XXX EDID SUCCESS CALIB : AV X COM X PC X HDMI X Option : XXXX XXXX XXXX X
SDAL-XXX RFS : 1000 T-TDT5AUSC 20XX-XX-XX TYPE : XX MODEL : XXXXX MAC Not Available LOCK X Factory Data Ver : XXX EERC Version : XXX DTP-AP-COMP-XXX DTP-HIIG-XXXX DTP-BP-XXXX Date of purchase : XX/XX/XXXX

\* How to enter the hidden factory mode.

- into the factory mode
- move the tap to Advanced
- key input : 0 + 0 + 0 + 0

\*\* hidden menu : Picture

#### 6. Buttons operations within Service Mode

Menu	Full Menu Display/Move to Parent Menu
Direction Keys ▲/▼	Item Selection by Moving the Cursor
Direction Keys ◀/▶	Data Increase / Decrease for the Selected Item
Source	Cycles through the active input source that are connected to the unit

## 4-3-2. Factory Data

## ■ Option

OPTION	Factory Name	Data	Range
	Factory Reset		
	Type	"26D6AH0E 32D6UF0E 32L6AF0C 37L6AF0C 40D6AF0C 46L6AF0C"	NONE/19O6TH0C/19A6TH0C/22I6TH0C/22A6TH0C/22D6TH0C/22P6TH0C/26A6AH0C/26D6AH0C/26L6AH0C/26P6AH0C/32A6AH0C/32D6AH0C/32L6AH0C/32P6AH0C/32A6AF0C/32L6AF0C/32A1AF0C/32L1AF0C/37L6AF0C/37L1AF0C/40A6AF0C/40D6AF0C/40L6AF0C/40A1AF0C/40L1AF0C/40A1UF0C/40D1UF0C/40L1UF0C/46A6AF0C/46D6AF0C/46L6AF0C/46A1AF0C/46L1AF0C/46A1UF0C/46D1UF0C/46L1UF0C/55A1UF0C/55L1UF0C/65L1UF0C/19O6TH0E/22D6TH0E/26D6AH0E/32D6AH0E/32D6UF0E/32A1UF0E/32D1UF0E/37L6UF0E/37D1UF0E/37L1UF0E/40D6UF0E/40A1UF0E/40D1UF0E/46D6UF0E/46L6UF0E/46A1UF0E/46D1UF0E/46L1UF0E/55A1UF0E/55D1UF0E/55L1UF0E/65L1UF0E/42HHcD3/50HHcD450FArN4/50FArV458FArN1/58FArV163FArN1/
	Local Set	...	
	Model	"LC450 LC530 LN540 LC550"	"LC350/LC450/LC450H/LC451LC452/LC457HLC459H/LC480/LC530/LC530H/LC539H/LC540/LC550/LC560/LC580/LC570/LC610/LC620/LC630/LC631/LC632/LC633/LC640/LC650/LC652/LC653/LC654/LC670/ UC4000/UC4000H/UC4010/UC5000/UC5100/UC6000/UC6200/UC6300/UC6400/UC6400H/UC6500/UC6510/UC6530/UC6540/UC6550/UC6600/UC6620/UC6630/UC6700/UC6720/UC6730/UC6740/UC6800/UC6830/UC6900/UC6900H/UC8000/ PC420/PC430/PC431/PC432/PC450/PC451/PC480/PC520/PC530/PC531/PC540/PC541/PC550/PC551/PC560/PC580/PC590/PC670/PC6100/PC6400/PC6500/PC7000/PC7700/PC8000"
	TUNER	DRX3900J	fixed
	DDR	0	fixed
	Light Effect	OFF	ON/OFF
	Ch Table	...	
	Country	USA	USA/PANAMA
	Front Color		NONE/W-MILKY/T-M-Brn/T-W-Brn/T-W-Gray/W-D-Gray/W-M-Whit/W-Violet/T-C-Gray/T-R-BLK/S-BLK/S-RBLK/S-C-Gray/

## ■ Control

<b>Control</b>	<b>Factory Name</b>	<b>Data</b>	<b>Range</b>
	EDID	SUB MENU	
	Sub Option	SUB MENU	
	PDP Option		
	Hotel Option	SUB MENU	
	Shop Option	SUB MENU	
	Asia Option	SUB MENU	INFO+FACTORY
	Sound	SUB MENU	
	Config Option	SUB MENU	INFO+FACTORY
	SCC	SUB MENU	INFO+FACTORY

<b>EDID</b>	<b>Factory Name</b>	<b>Data</b>	<b>Range</b>
	EDID ON/OFF	Off	ON/OFF
	EDID WRITE ALL	...	Success/failure
	EDID WRITE PC	...	Success/failure
	EDID WRITE HDMI	...	Success/failure
	EDID WRITE HDMI1	...	fixed
	EDID WRITE HDMI2	...	fixed
	EDID WRITE HDMI3	...	fixed
	EDID WRITE HDMI4	...	fixed
	EDID 1.2 PORT	NONE	NONE/Not Support/HDMI2/HDMI3/HDMI4
	EDID WRITE DVI	...	fixed

Sub Option	Factory Name		Data	Range
	RF Mute Time	600ms	0ms~1000ms	
	RS-232 Jack	UART	Debug/Login/UART	
	Watchdog	OFF	ON/OFF	
	WD Count	0	0~255	
	Dimm Type	EXT	fixed	
	Lvds Format	JEIDA	JEIDA/VESA/19INCH	
	Language_Arbic	...	fixed	INFO+FACTORY
	TOOLS Support	32	0~255	INFO+FACTORY
	LNA Support	0	0~255	INFO+FACTORY
	MediaPlay DB	On whth 5MB	fixed	
	MediaPlay Movie	chapterinMedia	fixed	
	MediaPlay DLNA	OFF	fixed	
	MediaPlay PlayList	OFF	fixed	
	NETWORK Support	Wireless	Not Support/Cable/Wireless	INFO+FACTORY
	Info Link Server Type	operating	operatingdevelopment/developing	INFO+FACTORY
	Info Link Country	USA	None/USA	INFO+FACTORY
	TTX List	...	fixed	INFO+FACTORY
	TTX Group	...	fixed	INFO+FACTORY
	24Px4 Support	OFF	ON/OFF	INFO+FACTORY
	Power Indicator Support	OFF	ON/OFF	INFO+FACTORY
	BD Wise Support	ON	ON/OFF	INFO+FACTORY
	Data Service Support	OFF	ON/OFF	INFO+FACTORY
	Alternate Del	OFF	ON/OFF	INFO+FACTORY
	OTN Server Type	operating	operation/development	
	OTN Test Server	OFF	OFF/ A/B/C/D/E Zone	
	OTN Support	OFF	ON/OFF	
	OTN Reset			
	OTN Duration	OFF	ON/OFF	
	OTN Fail Test	OFF	ON/OFF	
	IIC Bus Stop	OFF	ON/OFF	INFO+FACTORY
	Visual Test	Disable	fixed	INFO+FACTORY
	T-CON USB Download	Failure	fixed	
	Emergency Log Copy			INFO+FACTORY
	Checksum	0x0000		INFO+FACTORY
	View Log		SUB MENU	
	ColorSpace Support	HueSate Type	RGB Type / HueSate Type	INFO+FACTORY
	Gemstar On/Off	OFF	ON/OFF	INFO+FACTORY
	WSS Support	OFF	ON/OFF	INFO+FACTORY
	PVR Support	OFF	ON/OFF	INFO+FACTORY
	CI Support	OFF	ON/OFF	INFO+FACTORY

Eeprom Reset		SUB MENU	INFO+FACTORY
Spread Spectrum		SUB MENU	INFO+FACTORY
DDR Margin		SUB MENU	INFO+FACTORY
H.264 Margin	200	0~2000	
MPEG Margin	50	0~2001	
Tuner Margin	50	0~2002	
SST		SUB MENU	
SST_Th		SUB MENU	
2nd mips	ON	ON/OFF	
2nd mips count	0	0~255	
Region	KOR	fixed	
PnP Language	...	fixed	INFO+FACTORY
PC Auto Ident	Enable	Auto/Enable	

<b>Hotel Option</b>	<b>Factory Name</b>	<b>Data</b>	<b>Range</b>
	Hotel Mode	ON	Refer to Chapter "4.4 ~ 4.5"
	Power On Channel	3	"
	Channel Type	ATV	"
	Power On Volume	10	"
	Min Volume	0	"
	Max Volume	100	"
	Panel Button Lock	Unlock	"
	Power On Source	TV	"
	Picture Menu Lock	OFF	"
	Channel Editor		"
	Music Mode AV	OFF	"
	Music Mode PC	OFF	"
	Music Mode Comp	OFF	"
	Music Mode Backlight	OFF	"
	RJP Priority AV	1	"
	RJP Priority PC	2	"
	RJP Priority HDMI	3	"
	RJP AV Option	AV1	"
	RJP HDMI Option	HDMI1	"
	Sub Amp Volume	13	"
	Sub Amp Mode	2	"
	Local Time	Manual	"
	Menu Display	ON	"
	Hotel Logo	OFF	"
	Hotel Logo Download	...	"
	Logo Display Time	...	"
	Power On Option	Last Option	"
	Auto SOURCE	OFF	"
	Energy Saving	OFF	"
	Clone TV to USB		"
	Clone USB to TV		"
	Cloning Data Reset	OFF	"
	Welcome Message	OFF	"
	Edit Welcome Message		"
	Channel Auto Store		"
	Dynamic SI	ON	"

<b>Shop Option</b>	<b>Factory Name</b>	<b>Data</b>	<b>Range</b>
	Shop Mode	OFF	ON/OFF
	Exhibition Mode	OFF	ON/OFF

## 4-4. Setting the Hotel Option Data

### 4-4-1. Interactive Mode

To Enter: Press the INFO → MENU → 0 → 1 → EXIT buttons in order, in normal operation state.

To Exit from this menu : Power Off and Turn On again. (Press Power button with general SAMSUNG remote)

No	Item	initial Value	Description
1	Hotel Mode	On	Hotel mode on/off <ul style="list-style-type: none"> <li>On: Hotel TV Stand-alone or Interactive</li> <li>Off: Retail TV</li> </ul>
2	SI Vendor	Samsung	Select the SI Vendor SAMSUNG/OCC/MTI/NSTREAMS/DAW/Magilink/NXTV/Enseo
3	Power On Channel	3	When the TV is turned on, it switches automatically to this channel when in Interactive Hotel Mode.
4	Channel Type	ATV	Channel search CABLE and AIR. <ul style="list-style-type: none"> <li>ATD, DTV : ON-AIR</li> <li>CATV, CDTV (Cable Digital TV) : CABLE TV</li> </ul>
5	Power On Volume	10	TV will switch on at this Volume Level in Interactive Hotel Mode.
6	Min Volume	0	Minimum Volume Level setting user can set in Interactive Hotel Mode.
7	Max Volume	100	Maximum Volume Level setting user can set in Interactive Hotel Mode.
8	Panel Button Lock	Unlock	Front panel (Local key) operation on/off. <ul style="list-style-type: none"> <li>Off : Unlock All panel keys</li> <li>On : Lock All panel keys</li> <li>Power : Lock All panel buttons except Power</li> </ul>
9	Power On Source	TV	Select the input source the TV displays when it is turned on.
10	Picture Menu Lock	OFF	Enable or disable Picture Menu.
11	Music Mode AV	OFF	To get music output from mp3/audio player through an AV Input Source. When on, you can hear sound from the player through the TV whether there is a Video Signal or not.
12	Music Mode PC	OFF	To get music output from mp3/audio player through a PC Input Source. When on, you can hear sound from the player through the TV whether there is a Video Signal or not.
13	Music Mode Comp	OFF	To get music output from mp3/audio player through a Component Input Source. When on, you can hear sound from the player through the TV whether there is a Video Signal or not.
14	Music Mode Backlight	OFF	Backlight On/Off option in Music mode. To save energy, set to Off.
15	RJP Priority AV	1	If the jack priority is set, the TV will automatically select this source when a plug is inserted into the RJP AV jack, according to its jack priority.
16	RJP Priority PC	2	If the jack priority is set, the TV will automatically select this source when a plug is inserted into the RJP PC jack, according to its jack priority.
17	RJP Priority HDMI	3	If the jack priority is set, the TV will automatically select this source when a plug is inserted into the RJP HDMI jack, according to its jack priority.
18	RJP AV Option	AV1	Select RJP AV Source (AV1/AV2)
19	RJP HDMI Option	HDMI1	Select RJP HDMI Source (HDMI1/HDMI2/HDMI3).
20	Sub Amp Volume	13	Sub AMP Volume level at power on initial condition.

No	Item	initial Value	Description
21	Sub Amp Mode	2	Determines the Sub AMP operation mode. <ul style="list-style-type: none"> <li>0 : Turns the Sub AMP function off (PWM off).</li> <li>1 : Determines the Sub volume according to the main volume control.</li> </ul> That is, the sub volume is determined according to the Power On Volume, the Min Volume, and the Max.
22	Local Time	Manual	Select the way to update clock data <ul style="list-style-type: none"> <li>Auto: Use clock data from server</li> <li>Manual: Manual clock setting (without updating from TTX data)</li> <li>TTX: Manual clock setting (with updating from TTX data)</li> </ul>
23	Menu Display	ON	<ul style="list-style-type: none"> <li>On : Main Menu display.</li> <li>Off : Main Menu No display.</li> </ul>
24	Customer Logo	OFF	Turns the hotel logo feature on/off. Logo is shown during the initial turn on for the amount of time set in the "Logo Display Time".
25	Logo Download	...	Hotel Logo Download. (File name required: samsung.bmp, Max file size: 960 x 540, File Type: BMP)
26	Logo Display Time	...	Hotel Logo Display Time (3/5/7 seconds).
27	Power On Option	Last Option	Setting the TV state when the TV powers on. (AC Power On) <ul style="list-style-type: none"> <li>STN-BY : Stand-By Mode</li> <li>Power On : Power On</li> <li>LAST OPT : Last Power State (Stand-by or Power On)</li> </ul>
28	Auto Source	OFF	<ul style="list-style-type: none"> <li>ON : In stand-by mode, when external source is connected to the TV, the TV automatically goes to Power On and Auto Ident external input mode.</li> <li>PC : Auto Ident PC Input only.</li> <li>OFF : Auto Source is Off.</li> </ul>
29	Energy Saving	Off	This feature adjusts the brightness of the TV to reduce power consumption. <ul style="list-style-type: none"> <li>Off: Turns off the energy saving function.</li> <li>Low: Sets the TV to low energy saving mode.</li> <li>Medium: Sets the TV to medium energy saving mode.</li> <li>High: Sets the TV to high energy saving mode.</li> </ul>
30	Clone TV to USB		Clone the current TV option values to the USB.
31	Clone USB to TV		Clone the saved TV option values in the USB to the TV.
32	Cloning Data Reset	OFF	<ul style="list-style-type: none"> <li>ON : When TV powers on, resets all the option values in the saved Cloning Data in the TV.</li> <li>OFF : Option values will be set to the last values.</li> </ul>
33	Welcome Message	OFF	Display welcome Message for 5 seconds when the TV turns On.
34	Edit Welcome Message		Edit Welcome Message.
35	Channel Auto Store		Auto Memorize channels. When Hotel mode is on, channel search possible only in this mode.
36	Dynamic SI	ON	<ul style="list-style-type: none"> <li>ON : Check the DTV Program channel number. (DTV channel editor inaccessible)</li> <li>Off : No Check of the DTV Program channel number. (DTV channel editor accessible, but additional channel program number update not supported)</li> </ul>

 When Interactive mode is On, you cannot enter the Hotel Options by pressing the MUTE → 1 → 1 → 9 → ENTER button. To exit the Hotel Options, turn the power off.

## 4-4-2. Stand-alone Mode

To Enter: Press the MUTE → 1 → 1 → 9 → ENTER buttons in order.

To Exit from this menu : Power off, and then turn on again. Any changes you made are saved.

No	Item	initial Value	Description
1	Hotel Mode	ON	Hotel mode on/off. <ul style="list-style-type: none"> <li>• On : Hotel TV Stand-alone or Interactive</li> <li>• Off : Retail TV</li> </ul>
2	Power On Channel	3	When the TV is turned on, it switches automatically to this channel when in Stand alone Hotel Mode.
3	Channel Type	ATV	Channel search CABLE and AIR. <ul style="list-style-type: none"> <li>• ATD, DTV : ON-AIR</li> <li>• CATV, CDTV (Cable Digital TV) : CABLE TV</li> </ul>
4	Power On Volume	10	TV will switch on at this Volume Level in Stand alone Hotel Mode.
5	Min Volume	0	Minimum Volume Level setting user can set in Stand alone Hotel Mode.
6	Max Volume	100	Maximum Volume Level setting user can set in Stand alone Hotel Mode.
7	Panel Button Lock	Unlock	Front panel (Local key) operation on/off. <ul style="list-style-type: none"> <li>• Off : Unlock All panel keys</li> <li>• On : Lock All panel keys</li> <li>• Power : Lock All panel buttons except Power</li> </ul>
8	Power On Source	TV	Select the input source the TV displays when it is turned on.
9	Picture Menu Lock	OFF	Enable or disable Picture Menu.
10	Channel Editor		Edit Channel Number and Name.
11	Music Mode AV	OFF	To get music output from mp3/audio player through an AV Input Source. When on, you can hear sound from the player through the TV whether there is a video signal or not.
12	Music Mode PC	OFF	To get music output from mp3/audio player through a PC Input Source. When on, you can hear sound from the player through the TV whether there is a video signal or not.
13	Music Mode Comp	OFF	To get music output from mp3/audio player through a Component Input Source. When on, you can hear sound from the player through the TV whether there is a video signal or not.
14	Music Mode Backlight	OFF	Backlight On/Off option in Music mode. To save energy, set to Off.
15	RJP Priority AV	1	If the jack priority is set, the TV will automatically select this source when a plug is inserted into the RJP AV jack, according to its jack priority.
16	RJP Priority PC	2	If the jack priority is set, the TV will automatically select this source when a plug is inserted into the RJP PC jack, according to its jack priority.
17	RJP Priority HDMI	3	If the jack priority is set, the TV will automatically select this source when a plug is inserted into the RJP HDMI jack, according to its jack priority.
18	RJP AV Option	AV1	Select RJP AV Source. (AV1/AV2)
19	RJP HDMI Option	HDMI1	Select RJP HDMI Source. (HDMI1/HDMI2/HDMI3)
20	Sub Amp Volume	13	Sub AMP Volume level at power on initial condition.

No	Item	initial Value	Description
21	Sub Amp Mode	2	Determines the Sub AMP operation mode. <ul style="list-style-type: none"> <li>0 : Turns the Sub AMP function off (PWM off).</li> <li>1 : Determines the Sub volume according to the main volume control.</li> </ul> That is, the sub volume is determined according to the Power On Volume, the Min Volume, and the Max.
22	Local Time	Manual	Select the way to update clock data. <ul style="list-style-type: none"> <li>Auto: Use clock data from server</li> <li>Manual: Manual clock setting (without updating from TTX data)</li> <li>TTX: Manual clock setting (with updating from TTX data)</li> </ul>
23	Menu Display	ON	<ul style="list-style-type: none"> <li>On : Main Menu display.</li> <li>Off : Main Menu No display.</li> </ul>
24	Customer Logo	OFF	Turns the hotel logo feature on/off. Logo is shown during the initial turn on for the amount of time set in the "Logo Display Time"
25	Logo Download	...	Hotel Logo Download. (File name required: samsung.bmp, Max file size: 960 x 540, File Type: BMP)
26	Logo Display Time	...	Hotel Logo Display Time (3/5/7 seconds).
27	Power On Option	Last Option	Setting the TV state when the TV powers on. (AC Power On) <ul style="list-style-type: none"> <li>STN-BY : Stand-By Mode</li> <li>Power On : Power On</li> <li>LAST OPT : Last Power State (Stand-by or Power On)</li> </ul>
28	Auto Source	OFF	<ul style="list-style-type: none"> <li>ON : In stand-by mode, when external source is connected to the TV, the TV automatically goes to Power On and Auto Ident external input mode.</li> <li>PC : Auto Ident PC Input only.</li> <li>OFF : Auto Source is Off.</li> </ul>
29	Energy Saving	OFF	This feature adjusts the brightness of the TV to reduce power consumption. <ul style="list-style-type: none"> <li>Off: Turns off the energy saving function.</li> <li>Low: Sets the TV to low energy saving mode.</li> <li>Medium: Sets the TV to medium energy saving mode.</li> <li>High: Sets the TV to high energy saving mode.</li> </ul>
30	Clone TV to USB		Clone the current TV option values to the USB.
31	Clone USB to TV		Clone the saved TV option values in the USB to the TV.
32	Cloning Data Reset	OFF	<ul style="list-style-type: none"> <li>ON : When TV powers on, resets all the option values in the saved Cloning Data in the TV.</li> <li>OFF : Option values will be set to the last values.</li> </ul>
33	Welcome Message	OFF	Display welcome Message for 5 seconds when the TV turns On.
34	Edit Welcome Message		Edit Welcome Message.
35	Channel Auto Store		Auto Memorize channels. When Hotel mode is on, channel search possible only in this mode.
36	Dynamic SI	ON	<ul style="list-style-type: none"> <li>ON : Check the DTV Program channel number. (DTV channel editor inaccessible)</li> <li>Off : No Check of the DTV Program channel number. (DTV channel editor accessible, but additional channel program number update not supported)</li> </ul>

## 4-5. White Balance - Calibration

### 4-5-1. White Balance -Calibration

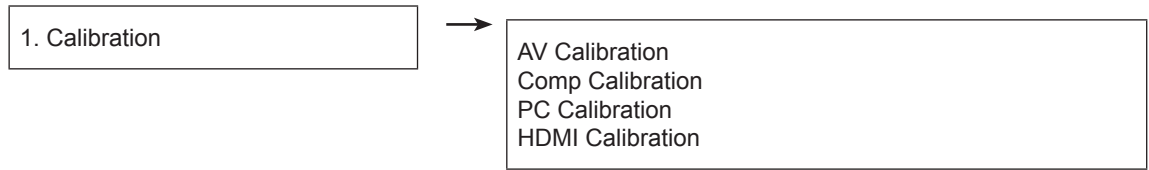

### 4-5-2. Service Adjustment

You must perform Calibration in the Lattice Pattern before adjusting the White Balance.

#### ■ Color Calibration

Adjust spec.

- 1. Source : HDMI
- 2. Setting Mode : 1280\*720@60Hz
- 3. Pattern : Pattern #24 (Chess Pattern)

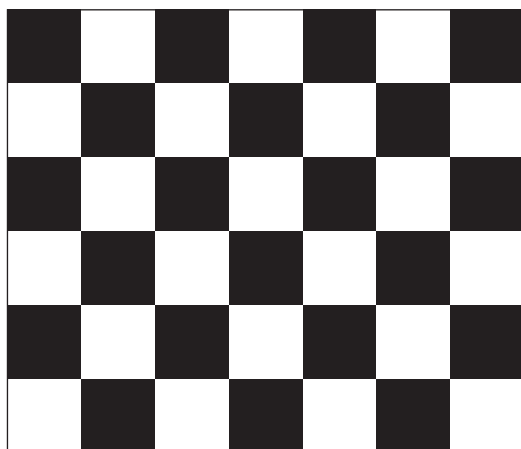

( Chess Pattern )

4. Use Equipment : CA210 & Master MSPG925 Generator

- Use other equipment only after comparing the result with that of the Master equipment.

Input mode	Calibration	Pattern
CVBS IN (Model_#1)	Perform in NTSC B&W Pattern #24	Lattice
Component IN (Model_#6)	Perform in 720p B&W Pattern #24	Lattice
PC Analog IN (Model_#21)	Perform in VESA XGA (1024x768) B&W Pattern #24	Lattice
HDMI IN	Perform in 720p B&W Pattern #24	Lattice

<Table 1>

### ■ Method of Color Calibration (AV)

- 1) Apply the NTSC Lattice (N0. 3) pattern signal to the AV IN 1 port
- 2) Press the Source key to switch to "AV1" mode
- 3) Enter Service mode
- 4) Select the "Calibration" menu
- 5) Select the "AV Calibration" menu.
- 6) In "AV Calibration Off" status, press the "▶" key to perform Calibration.
- 7) When Calibration is complete, it returns to the high-level menu.
- 8) You can see the change of the "AV Calibration" status from Failure to Success.

### ■ Method of Color Calibration (Component)

- 1) Apply the 720p Lattice (N0. 6) pattern signal to the Component IN 1 port
- 2) Press the Source key to switch to "Component1" mode
- 3) Enter Service mode
- 4) Select the "Calibration" menu
- 5) Select the "Comp Calibration" menu.
- 6) In "Comp Calibration Off" status, press the "▶" key to perform Calibration.
- 7) When Calibration is complete, it returns to the high-level menu.
- 8) You can see the change of the "Comp Calibration" status from Failure to Success.

### ■ Method of Color Calibration (PC)

- 1) Apply the VESA XGA Lattice (N0. 21) pattern signal to the PC IN port
- 2) Press the Source key to switch to "PC" mode
- 3) Enter Service mode
- 4) Select the "Calibration" menu
- 5) Select the "PC Calibration" menu.
- 6) In "PC Calibration Off" status, press the "▶" key to perform Calibration.
- 7) When Calibration is complete, it returns to the high-level menu.
- 8) You can see the change of the "PC Calibration" status from Failure to Success.

### ■ Method of Color Calibration (HDMI)

- 1) Apply the 720p Lattice (N0. 6) pattern signal to the HDMI1/DVI IN port
- 2) Press the Source key to switch to "HDMI1" mode
- 3) Enter Service mode
- 4) Select the "Calibration" menu
- 5) Select the "HDMI Calibration" menu.
- 6) In "HDMI Calibration Off" status, press the "▶" key to perform Calibration.
- 7) When Calibration is complete, it returns to the high-level menu.
- 8) You can see the change of the "HDMI Calibration" status from Failure to Success.

### 4-5-3. White Balance - Adjustment

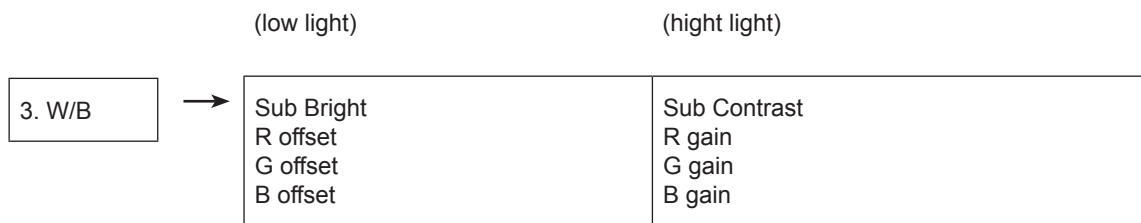

(W/B adjustment Condition refer next page)

### 4-6. White Ratio (Balance) Adjustment

1. You can adjust the white ratio in factory mode (1:Calibration, 3:White-Balance).
2. Since the adjustment value and the data value vary depending on the input source, you have to adjust these in CVBS, Component 1 and HDMI 1 modes.
3. The optimal values for each mode are configured by default. (Refer to Table 1, 2)  
It varies with Panel's size and Specification.

- Equipment : CS-210
- Pattern: MIK K-7256 #92 "Flat W/B Pattern" as standard
- Use other equipment only after comparing the result with that of the Master equipment.
- Set Aging time : 60min ↑
- Calibration and Manual setting for WB adjustment.



- HDMI : Calibration at #24 Chessboard Pattern → Manual adjustment #92 pattern (720p)
- COMP: Calibration at #24 Chessboard Pattern → Manual adjustment at #92 pattern (720p)
- CVBS: Calibration at #24 Chessboard Pattern → Manual adjustment at #92 pattern (NTSC)
- If finishing in HDMI mode, adjustment coordinate is almost same in AV/COMP mode.
- White Balance Manual Adjustment

• **37C539**

P-Mode	Adjustment Coordinate CA-210				
		x	y	Y (Luminance)	T(K) + MPCD
[ Dynamic Cool1 ] HDMI Comp CVBS	H/L	272	278	63.5 fL (Sub_CT:134 Fix)	12,000 (±0)
	L/L	272	278	4.8 fL (Sub-Br:128 Fix)	12,000 (±0)
[ Movie Warm2 ] HDMI Comp CVBS	H/L	306	327	- (Sub_CT:Unadjusted)	6,500 (+6)
	L/L	306	327	- (Sub_Brt:Unadjusted)	6,500 (+6)

• **40C530/C539**

P-Mode	Adjustment Coordinate CA-210				
		x	y	Y (Luminance)	T(K) + MPCD
[ Dynamic Cool1 ] HDMI Comp CVBS	H/L	272	278	64.1 fL (Sub_CT:134 Fix)	12,000 (±0)
	L/L	272	278	4.9 fL (Sub-Br:128 Fix)	12,000 (±0)
[ Movie Warm2 ] HDMI Comp CVBS	H/L	306	327	- (Sub_CT:Unadjusted)	6,500 (+6)
	L/L	306	327	- (Sub_Brt:Unadjusted)	6,500 (+6)

• **46C539**

P-Mode	Adjustment Coordinate CA-210				
		x	y	Y (Luminance)	T(K) + MPCD
[ Dynamic Cool1 ] HDMI Comp CVBS	H/L	272	278	66.5 fL (Sub_CT:134 Fix)	12,000 (±0)
	L/L	272	278	4.9 fL (Sub-Br:128 Fix)	12,000 (±0)
[ Movie Warm2 ] HDMI Comp CVBS	H/L	306	327	- (Sub_CT:Unadjusted)	6,500 (+6)
	L/L	306	327	- (Sub_Brt:Unadjusted)	6,500 (+6)

- **32C450/C459**

P-Mode	Adjustment Coordinate CA-210				
		x	y	Y (Luminance)	T(K) + MPCD
[ Dynamic Cool1 ] HDMI Comp CVBS	H/L	272	278	64.1 fL (Sub_CT:134 Fix)	12,000 (±0)
	L/L	272	278	4.6 fL (Sub_Brt:128 Fix)	12,000 (±0)
[ Movie Warm2 ] HDMI Comp CVBS	H/L	306	327	- (Sub_CT:Unadjusted)	6,500 (+6)
	L/L	306	327	- (Sub_Brt:Unadjusted)	6,500 (+6)

- **26C450/C459**

P-Mode	Adjustment Coordinate CA-210				
		x	y	Y (Luminance)	T(K) + MPCD
[ Dynamic Cool1 ] HDMI Comp CVBS	H/L	272	278	63.0 fL (Sub_CT:134 Fix)	12,000 (±0)
	L/L	272	278	5.3 fL (Sub_Brt:128 Fix)	12,000 (±0)
[ Movie Warm2 ] HDMI Comp CVBS	H/L	306	327	- (Sub_CT:Unadjusted)	6,500 (+6)
	L/L	306	327	- (Sub_Brt:Unadjusted)	6,500 (+6)

- Adjustment Specification

White Balance : High light (±1), Low light (±3)

Luminance : High light (Don't care), Low light (±0.2 Ft/L)

## 4-7. Servicing Information

### 4-7-1. USB Download Method

Software Upgrade upgrades can be performed via broadcasting signal or by downloading the new firmware from [samsung.com](http://samsung.com) to a USB memory device.

Current Version is the software already installed in the TV.

**Note** Software is represented as 'Year/Month/Day\_Version'.  
Installing the latest version is recommended.

- ▶ **By USB:** Insert a USB drive containing the firmware upgrade file downloaded from [samsung.com](http://samsung.com) into the TV. Please be careful not to disconnect the power or remove the USB drive until upgrades is complete. The TV will turn off and on automatically after completing the firmware upgrade. When software is upgraded, video and audio settings you have made will return to their default settings. We recommend you to write down your settings so that you can easily reset them after the upgrade.
- ▶ **By Online:** Upgrades the software using the Internet.
  - Note** First, configure your network.  
For detailed procedures on using the Network Setup, refer to the 'Setting the Network' instructions.
  - Note** If the internet connection doesn't operate properly, the connection may be broken.  
Please retry downloading. If the problem still happens, download by USB and upgrade.
- ▶ **Alternative Software (Backup):** If there is an issue with the new firmware and it is affecting operation, you can change the software to the previous version.
  - Note** If software was changed, existing software is displayed.

## 4-8. Hotel Plug & Play

Hotel Plug & Play is a function that automatically performs the Hotel mode selection, Country Setup, Clock Setup and Picture mode Setup once, when power is first turned ON, after a Service Reset is executed.

### UI Scenario

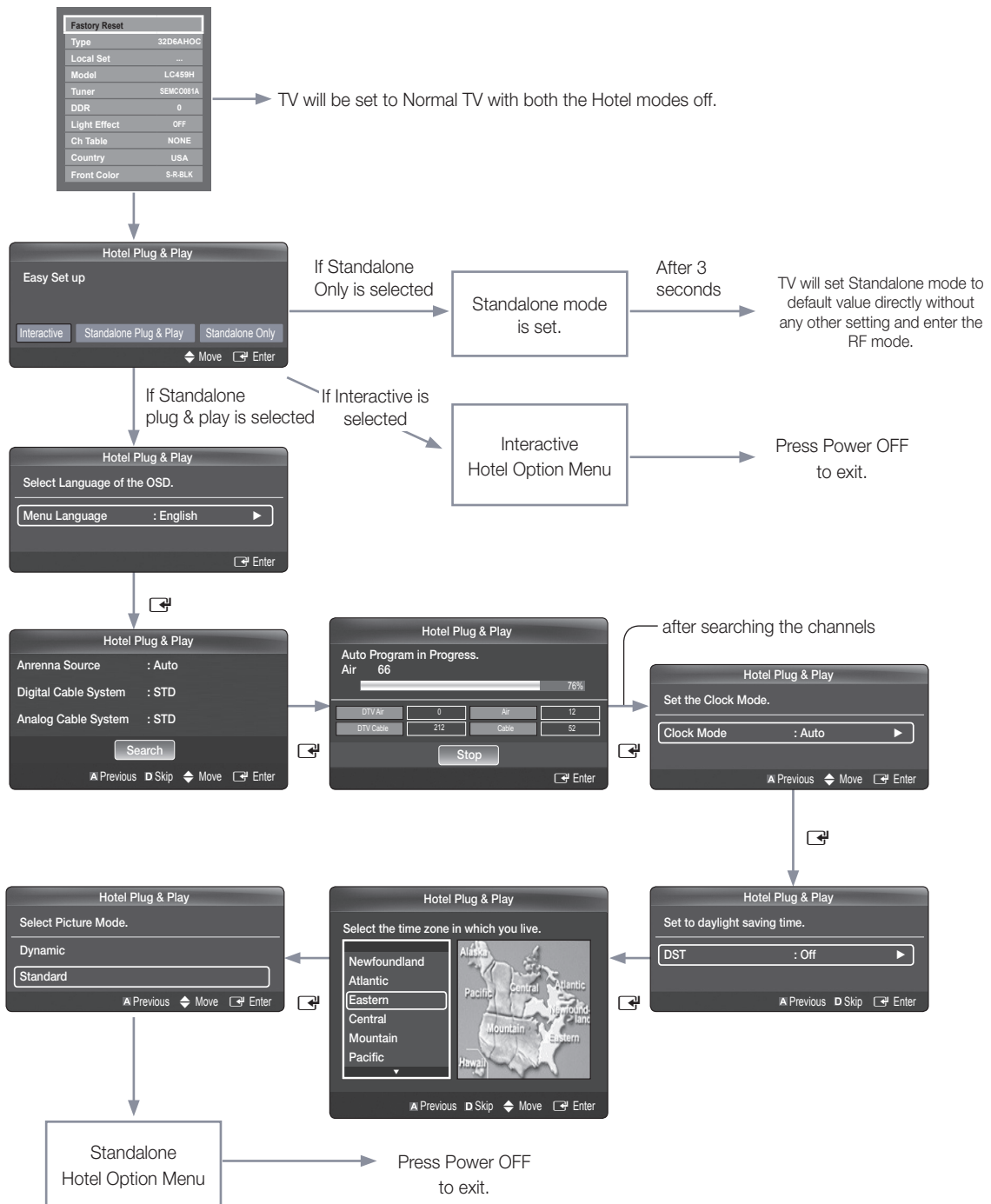

- **Hotel Plug & Play OSD**
  - Initial Highlight: Interactive
  - If you select the Standalone Only button, the Standalone hotel mode is set by default and the “Standalone mode is set” OSD appears for 3 seconds.
  - TV enters into RF mode automatically after displaying “Standalone mode is set” OSD for 3 seconds.
  - If you select the Interactive mode, the Interactive Setup Menu is displayed. Press the power off key to exit from Interactive menu.
  - If you select the Standalone Plug & Play mode, the “Select Menu Language” OSD appears.
  
- **Select Menu Language OSD**
  - If you select Standalone from the “Select Hotel TV Mode” OSD, the “Select Menu Language” OSD appears.
  - Initial Highlight : English
  - Display time: OSD timeout and operation are the same as Samsung's consumer TV models.
  - If you press the Enter key, the “Select Country” OSD appears
  
- **Auto Search Mode OSD**
  - If you select the Skip option, the TV displays the Clock Mode OSD.
  - If you press the Enter key, the TV auto searches for channels.
  - The OSD Display time, which starts at the time that Auto Store is completed goes to the time Auto Sort starts, is 30 seconds.
  
- **Clock Mode OSD**
  - Initial Highlight: Auto.
  - Display time: 30 seconds.
  - The Clock Set item OSD appears if you select Manual.
  - If you press the Enter key after setting the clock, or while in Auto clock set, the Picture Mode OSD appears.
  
- **Set daylight saving time OSD**
  - Initial Highlight: Off
  - If you press the Enter key, the Select the DST area OSD appears.
  
- **Picture Mode OSD**
  - Initial Highlight: Dynamic.
  - The TV displays the Picture Mode OSD where you can choose the Dynamic or a Standard Picture mode.
  - After you select the picture mode, the TV displays the Standalone Setup Menu OSD. Press power off to exit.

## ■ Hotel Option

### Instruction

This TV is provided with functionality that lets it interact with a set-back box (SBB/STB) connected to the TV, and with other TVs in a computer controlled system for hotels and other hospitality businesses.

**Interactive** : When the TV is powered-up initially, it sends a command to identify the connected SBB/STB. If it identifies the SBB/STB, the TV switches to ONLINE mode which gives full control of the TV to the SBB/STB. When the TV is in ONLINE mode, it stops accepting IR (Samsung remote) commands and acts according to the interface protocol.

**Stand-Alone**: If SBB/STB is not identified, the TV should be switched to STAND-ALONE mode with restricted operation.

### Operational Modes

When this TV (in Hotel mode) is operated with a SBB/STB, it is in one of two states: ONLINE or STAND-ALONE

- In the STAND-ALONE state, the TV will act as a Hotel TV, but without active communication. This is to prevent guests from trying to cheat the system by disconnecting the SBB/STB.

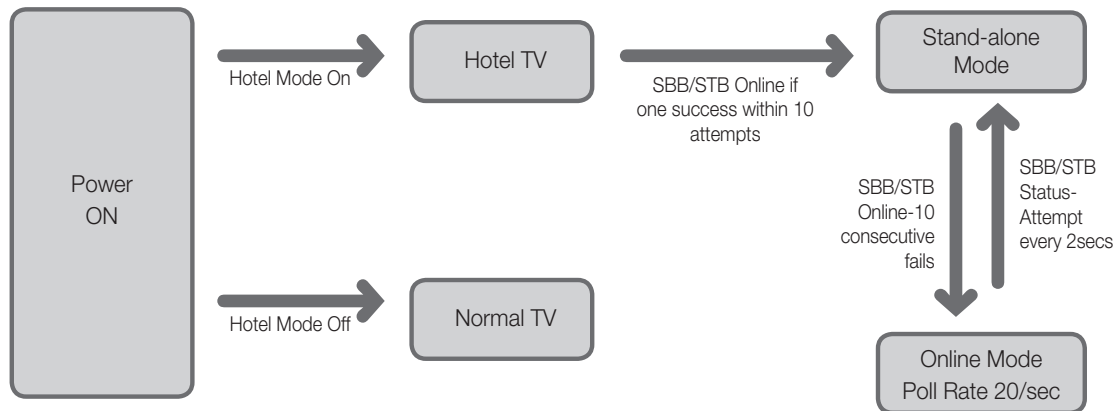

To set the details for Stand-alone or Interactive (Online) mode, refer to Chapter 4-4 (Setting the hotel option data : Stand-alone mode and Interactive mode)

- All (or some) operations may be restricted to prevent guests from "cheating" the TV system.
- Limited Volume and Panel button lock or unlock

## Connecting the TV with SBB

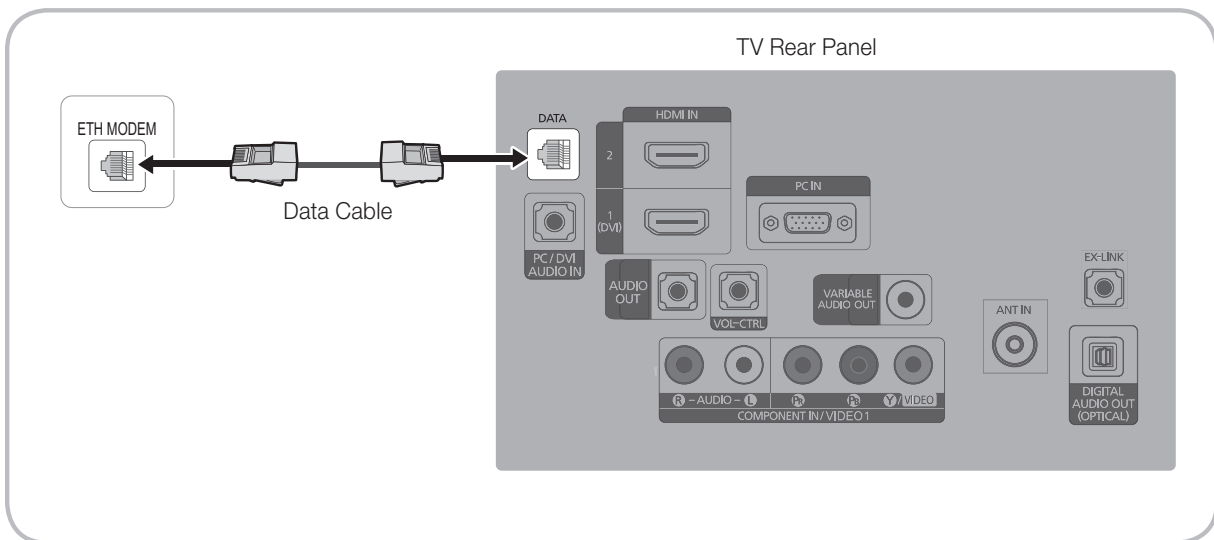

1. Connect the **DATA** jack of the TV to the **ETH MODEM** jack of the STB (SBB) with the Data cable.  
✎ Use data communication.

### List of SI Vendors for Compatible Data Cables Supplied with the TV

- Refer to the code label on the data cables.

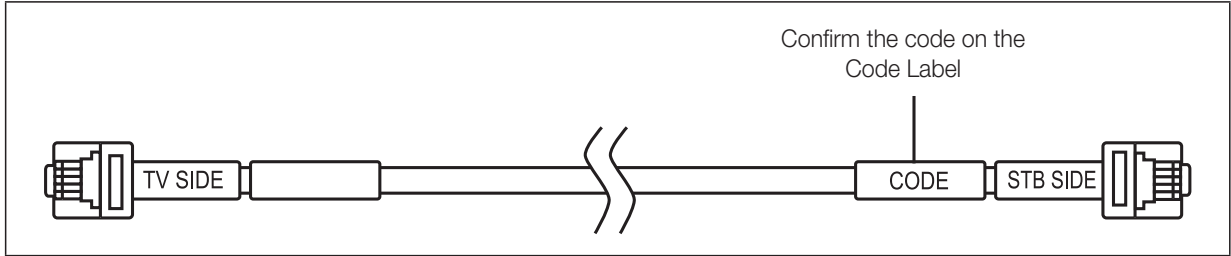

Vendor	Cable code	Pin assign	Remark
OCC	BN39-00865B		
NXTV	BN39-01011B		
nStreams	BN39-01110A		
MTI	BN39-01011C		LodgeNet MTI
DAW	BN39-00865B		MPEG4 STB

### Connecting the Bathroom Speakers

You can connect the Bathroom Speakers in one of the following 2 methods.

#### Connecting through the Variable Output (available without an external amplifier)

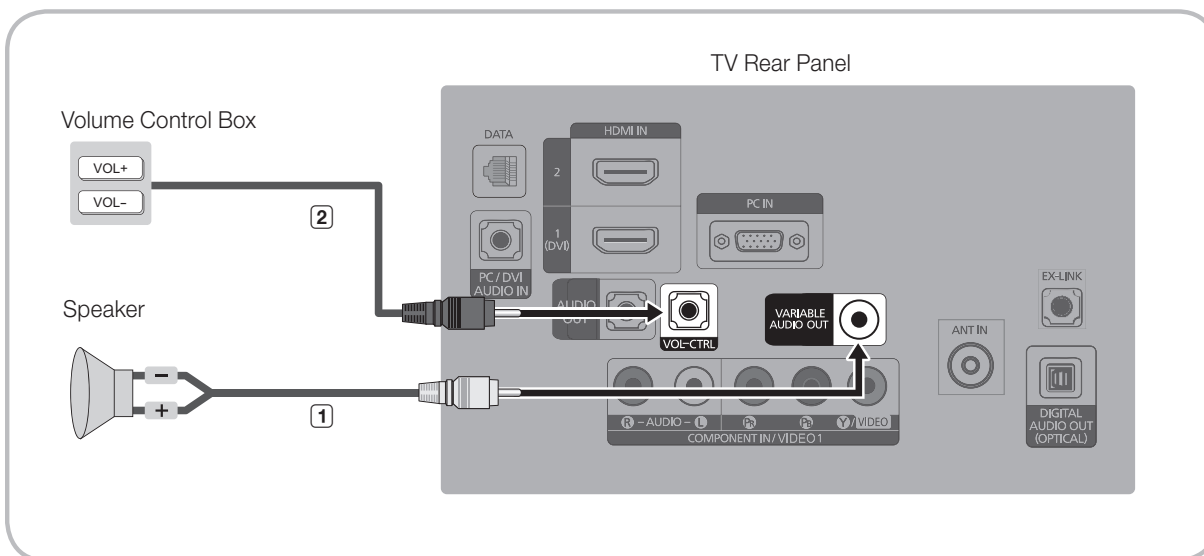

1. Connect the **VARIABLE AUDIO OUT** port of the TV to the Bathroom Wall Speakers of the hotel.
2. Connect the **VOL-CTRL** jack of the TV to the Volume Control Box Switch port of the Bathroom Wall of the hotel.



- The maximum speaker output is 4W, 8Ω.
- When the **MUTE** button on the remote control is pressed or the Headphone or the earphone are connected to the TV, all sound from the Main speaker and the Bathroom speaker is muted.

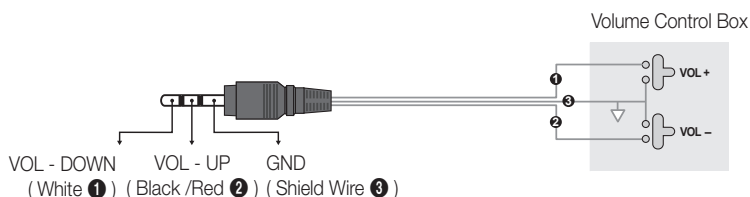

- Installing the Volume Control
  - If you configure the Volume Control Box as shown in the figure, you can control the volume of the bathroom speakers.
  - The jack that is connected from the Volume Control Box to the TV is a normal Phone jack.
  - Volume Control Box switch consists of Tact switch.
  - Setting the Sub AMP Mode
    - 0: Turns the Sub AMP function off (PWM off).
    - 1: Determines the Sub volume according to the main volume control. That is, the sub volume is determined according to the Power On Volume, the Min Volume, and the Max Volume values of the Hotel Mode.
    - 2: Determines the volume according to the bathroom control panel setting.
- Variable Output Port Specifications
  - 8Ω, 4W(Mono)
  - Speaker Wire: Use speaker cable no more than 82 feet (25m) in length.

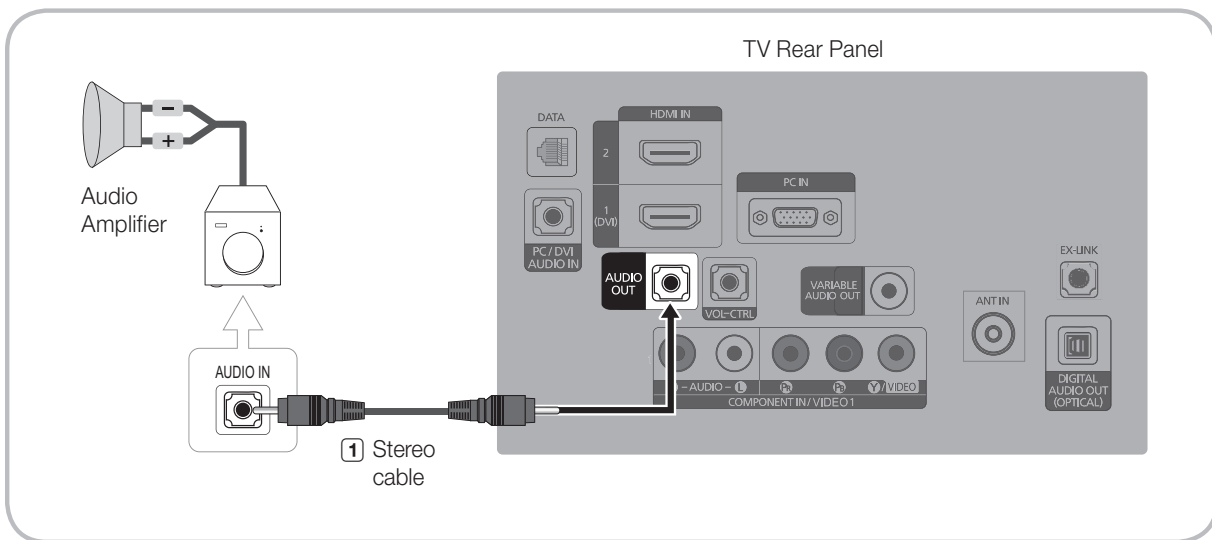

**Connecting through the Variable Output (available without an external amplifier)**

1. Connect the **AUDIO OUT** port of the TV and the Audio In port of the audio amplifier with a stereo cable.



- **RJP (Remote Jack Pack):** RJP stands for Remote Jack Pack. The RJP is a hardware module that has different Audio Video inputs (A/V, Audio, PC and HDMI) and corresponding outputs. The corresponding output sources are connected from the RJP to the TV. The RJP communicates with the TV via RS232. Hot Plug & Play is a function that allows hotel guests to connect an external source to the RJP. The RJP communicates with the TV by sending messages regarding Active/Inactive sources. The TV will switch to the Active external source according to the priority set by the User.
  -  You can select HDMI 1,2,3 and AV 1,2 for connecting the RJP.
  -  When the TV is on, connect the TV and the RJP within 10 seconds.
- The RJP can be returned to the factory default settings by pressing the A/V and HDMI buttons simultaneously for 10 seconds. All LEDs blink 5 times, acknowledging that the reset has been performed
- The RJP will automatically turn off any LEDs after 5 minutes to avoid unnecessary light pollution in the hotel room. The LEDs that were turned off will turn on again if the guest touches any of the buttons and the 5 minute timer will restart. If the guest then touches another source button, the TV will change to the selected source and the corresponding LED will be lit.
- After an RJP Reset or a TV Power OFF/ON, it takes approx. 10 seconds to establish communications between the TV and the RJP.
- The following table shows the approximate time in seconds to switch from the TV to the input source, based on the priority.

 Scenario 1: When no inputs are connected.

Source	To Connect
AV	2 Sec
PC	0.7 Sec
HDMI	3.9 Sec



 Scenario 2: When two or more inputs are connected and an Input source is disconnected and then reconnected.

Source	Disconnect	To Connect	Total
AV	4.5 Sec	2 Sec	6.5 Sec
PC	0.7 Sec	0.7 Sec	1.4 Sec
HDMI	3.9 Sec	3.9 Sec	7.8 Sec

 E.g. If the RJP has all its live sources AV, PC and HDMI connected, AV is viewed as the highest priority. If the RJP is in HDMI mode, and a guest removes and reconnects the AV, the minimum time required to switch to the AV is 6.5 seconds.

- To connect audio (Ipod or Mp3), Music mode should be ON and Jack Ident detect should be OFF.
- AV, PC and HDMI input sources are supported.

## Economical Solutions

 MENU  → Picture → ECO Solution → ENTER 

- **Energy Saving (Off / Low / Medium / High / Picture Off / Auto):**  
This adjust the brightness of the TV in order to reduce power consumption.  
If you select Picture Off, the screen is turned off , but the sound remains on.  
Press any button to turn on the screen again.
- **Eco Sensor (Off / On :**  
To enhance your power savings; the picture settings will automatically adapt to the light in the room.  
**Min Backlight:** When ECO sensor is On, the minimum screen brightness can be adjusted manually.
- **No Signal Stand by (Off / 15 min / 30 min / 60 min) :**  
Sets how quickly the TV switches to standby mode, if no picture is being received.
  - Disabled when the PC is in power saving mode.

## 5. Exploded View & Part List

### 5-1. LN32C459E1G Exploded View

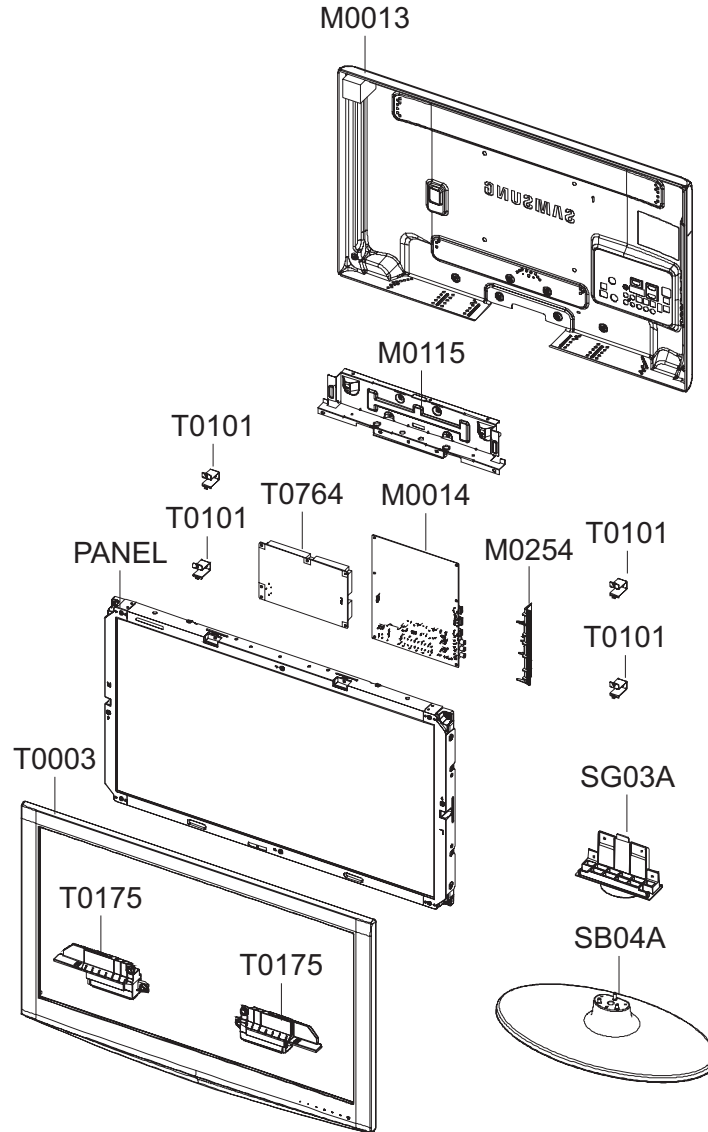

#### 5-1-1. LN32C459E1G Parts List

Location No.	Code No.	Description & Specification	Q'ty	SA/SNA	Remark
M0013	BN96-12737H	ASSY COVER P-REAR;LC450 32,UO(HOTEL),PCM	1	SA	
M0014	BN94-03377M	ASSY PCB MAIN;LN32C459E1HXZA	1	SA	
M0115	BN61-06024A	BRACKET-STAND LINK;LC550 32",SECC,T1.2	1	SNA	
M0254	BN61-06066A	HOLDER-SIDE AV;LC550,PC+ABS,V0,BK0008	1	SNA	
PANEL	BN07-00819A	LCD-PANEL;V315B5-L06,CM31B56,8bits,31.5,	1	SA	
SB04A	BN96-12150D	ASSY STAND P-BASE;LC451,459 32,SWIVEL,AB	1	SA	
SG03A	BN96-14077A	ASSY STAND P-GUIDE;LC450 32,SWIVEL,PC+G/	1	SA	
T0003	BN96-12733K	ASSY COVER P-FRONT;LC450 32,ZA(HOTEL),PC	1	SA	
T0101	BN61-05996A	BRACKET-WALL;LC650 40,SECC,T1.2	4	SNA	
T0175	BN96-12871A	ASSY SPEAKER P;6ohm,4pin,10W,L:530 R:170	1	SA	
T0764	<a href="#">BN44-00338B</a>	DC VSS-LCD TV;P2632HD_ADY,P2632HD_ADY,AC	1	SA	

## 5-2. LN32C459E1G Parts List

Service Bom (SA: SERVICE AVAILABLE, SNA: SERVICE NOT AVAILABLE)

Level	Location No.	Code No.	Description & Specification	Q'ty	SA/SNA	Remark
0.1		BN90-02428K	ASSY COVER FRONT;LC450 32	1	SNA	
..2	T0527	AA68-03539A	LABEL BAR CODE;65X40mm,ART PAPER	1	SNA	
..2	T0003	BN96-12733K	ASSY COVER P-FRONT;LC450 32,ZA(HOTEL),PC	1	SA	
...3	M0081	6003-001003	SCREW-TAPTYPE;BH,+,B,M4,L12,ZPC(BLK),SWR	4	SA	
...3	AB326	BN61-04661A	BRACKET-STOPPER;L650,SK-5,T0.4,Plating,H	2	SNA	
...3	CCM1	BN63-02183F	COVER-SHEET;Rhcm,PE Vinyl,T0.04,900mm,20	0.6	SNA	
...3	CCM1	BN63-05199D	COVER-SHEET;AMBER,PE,T0.08,W75mm,200M,CL	2	SNA	
...3	M0125	BN96-13421B	ASSY BOARD P-TOUCH FUNCTION&IR;LN32C459E	1	SA	
...3	F001	BN63-06502P	COVER-FRONT;LC450 32,UO(HOTEL),PC,V0,RD0	1	SNA	
...3		BN96-13186B	ASSY HOLDER P-BOSS;LC450 32,ABS,V0,WT003	1	SNA	
....4		BN61-04731B	BOSS-TAPE;AMBER,ACRYL,T1.1,W12.0mm,WHITE	0.5	SNA	
....4		BN61-06138B	HOLDER-BOSS BOTTOM;LC450 32,ABS,V0,WT003	1	SNA	
...3	CCM1	BN63-05199H	COVER-SHEET;AMBER,PE,T0.08,W130mm,200M,C	0.9	SNA	
...3	FD01A	BN96-13178B	ASSY DECORATION P;LC450 32,PC,CLEAR,V0,T	1	SNA	
....4	W391	<a href="#">6003-000275</a>	SCREW-TAPTYPE;BH,+,B,M3,L10,ZPC(BLK),SWR	4	SA	
....4	RS01	BN63-06503B	COVER-REAR SUB;LC450 32,HIPS,V0,BK0020	1	SNA	
....4	AD070	BN64-01259A	DECORATION-BOTTOM;LC450 32,PC CLEAR,V2,T	1	SNA	
...3	XT01	0201-001578	ADHESIVE-HM;HM-555,WHT,4,000 Cps	0.03	SNA	
...3		BN60-00162V	SPACER-FOAM;FOAM,50000mm,Dark Gray,0.5T,	2.18	SNA	
..2	T0175	BN96-12871A	ASSY SPEAKER P;6ohm,4pin,10W,L:530 R:170	1	SA	
0.1	S001A	BN90-02527K	ASSY STAND;LC350 32	1	SNA	
..2	SB04A	BN96-12150D	ASSY STAND P-BASE;LC451,459 32,SWIVEL,AB	1	SA	
...3	T0081	<a href="#">6002-001294</a>	SCREW-TAPPING;BH,+,M4,L16,ZPC(BLK)	4	SA	
...3	M0081	<a href="#">6003-001239</a>	SCREW-TAPTYPE;FH,+,B,M4,L10,ZPC(WHT),SWR	4	SNA	
...3	T0010	BN61-02232A	HOLDER-SWIVEL RING;32R71,ACETAL NATUAL,N	1	SNA	
...3	T0010	BN61-02233A	HOLDER-SWIVEL RING;32R71,ACETAL NATUAL,N	1	SNA	
...3		BN61-02236A	BRACKET-HINGE SWIVEL;BORDEAUX 32,SECC,T1	1	SNA	
...3		BN61-05710A	BRACKET-STAND BOTTOM;LB450,SECC,GL,T1.2	1	SNA	
...3		BN61-05844A	BRACKET-SUPPORT SWIVEL;LB450 32,SECC,T1.	1	SNA	
...3	CCM1	BN63-02183D	COVER-SHEET;Rhcm,PE Vinyl,T0.04,680mm,20	0.4	SNA	
...3		BN63-04355A	COVER-STAND BASE;L450 32INCH,ABS+PMMA,HB	1	SNA	
...3	M0019	BN73-00052C	RUBBER-FOOT;LCD TV,CR RUBBER,T2.0 DIA19,	4	SNA	
...3	M0523	<a href="#">BN96-07934A</a>	ASSY STAND P-GUIDE BOTTOM;BOTTOM;L450,V0	1	SA	
....4		BN61-02932B	BRACKET-STOPPER NUT;L450,M4,OD8,L24,MOLD	3	SNA	
....4	T0920	BN61-03872A	GUIDE-STAND BOTTOM;32,L450,PC+GF,20% V2,	1	SNA	
...3		BN74-00031A	GREASE;kanto-kasei FL-955,grease,wht	0.8	SNA	
...3		BN61-04692A	BOSS-PRIMER,#94,clear,35cps	0.1	SNA	
..2	SG03A	BN96-14077A	ASSY STAND P-GUIDE;LC450 32,SWIVEL,PC+G/	1	SA	
...3	T0524	6902-001048	BAG PE;LDPE,T0.05,W160,L300,TRP,4g	1	SNA	
...3	SG03	BN61-06625A	GUIDE-STAND;C450 32inch,PC+GF 20%	1	SNA	
...3		BN63-07207A	COVER-STAND NECK;LC450 32INCH,ABS+PMMA,H	1	SNA	
...3		BN68-02765D	MANUAL FLYER-STAND GUIDE;LN32C450E1G LN3	1	SNA	
...3	M0045	BN96-01800D	ASSY ACCESSORY-SCREW ZIPPER;CORAL,Withou	1	SNA	
....4	M0081	<a href="#">6003-001334</a>	SCREW-TAPTYPE;BH,+,S,M4,L14,ZPC(BLK),SWR	3	SNA	
....4		6902-000683	BAG ZIPPER;LDPE,T0.05,W60,L60,TRP,4-PE M	1	SNA	
....4		BN68-01628A	LABEL-SCREW;ART PAPER 100G,T0.08,White,D	1	SNA	
...3		BN96-12031U	ASSY ACCESSORY-SCREW;LC750,6003-001003,(	1	SNA	
....4	M0081	6003-001003	SCREW-TAPTYPE;BH,+,B,M4,L12,ZPC(BLK),SWR	4	SA	

Level	Location No.	Code No.	Description & Specification	Q'ty	SA/SNA	Remark
....4		6902-000336	BAG ZIPPER;LDPE,T0.05,W70,L80,TRP,0.500g	1	SNA	
0.1		BN91-05024A	ASSY LCD-CMO;BN07-00819A	1	SNA	
..2	PANEL	BN07-00819A	LCD-PANEL;V315B5-L06,CM31B56,8bits,31.5,	1	SA	
...3	M0059	BN81-04464A	A/S-INV V315B5-L06;V315B5-L06	1	SNA	
0.1	M0017	BN91-05118G	ASSY CHASSIS;LN32C459E1HXZA	1	SNA	
..2	M0014	BN94-03377M	ASSY PCB MAIN;LN32C459E1HXZA	1	SA	
...3		0202-001608	SOLDER-WIRE FLUX;LFC7-107,D0.8,99.3Sn/0.	0.125	SNA	
...3		3701-001480	CONNECTOR-DSUB;15P,3R,FEMAIL,STAMPED PIN	1	SA	
...3	CN906	3707-001096	CONNECTOR-OPTICAL;STRAIGHT W/L,SPDIF	1	SA	
...3		3711-007302	HEADER-BOARD TO BOARD;BOX,18P,2R,2mm,ANG	1	SA	
...3		3722-003037	JACK-USB;4P/1C W/L,AU/NI,BLK,ANGLE,A	1	SA	
...3	JA330	3722-003038	JACK-PHONE;7P/1C W/L,SN,BLK	4	SA	
...3	JA333	3722-003040	JACK-PIN;3P W/L,SN,BLK/YEL/WHT/RED,ANGLE	1	SA	
...3		3722-003047	JACK-MODULAR;6P/6C,YES,NO,AU/NI,1PORT	1	SA	
...3	JA333	3722-003048	JACK-PIN;1P W/L,NI/SN,BLK,STRAIGHT	1	SA	
...3	JA333	3722-003052	JACK-PIN;5P+Shield W/L,NI/SN,GN/BL/RD/WH	1	SA	
...3	T0010	AA61-00356B	HOLDER;501F,ABS,BLK,HB	1	SNA	
...3	T0756	AA68-01018A	LABEL-PQS;50mmX,13,WHITE	1	SNA	
...3	CIS3	BN40-00163A	TUNER;DTVS20CVL081A,NTSC,191CH,45.75MHz,	1	SA	
...3	M0412	BN96-11826C	ASSY BRACKET P-PCB;LB450 40,SPTT 0.5 +	1	SNA	
....4		BN61-04928C	BRACKET-SUPPORT PCB;SPTT,T 0.5,SCREW-M4	1	SNA	
....4		BN61-05262B	HOLDER-BOSS PCB;52,LB550(EO),PBT+G/F(30%	1	SNA	
...3	T0174	BN97-04213E	ASSY SMD;LN26C459E1HXZA,301	1	SNA	
....4		0202-001767	SOLDER-CREAM;LST-5710,D20~38,42Sn/57Bi/1	0.155	SNA	
....4	DS01A	0401-001056	DIODE-SWITCHING;MMBD4148SE,100V,200mA,SO	14	SA	
....4		0403-001783	DIODE-ZENER;BZB84-C6V2,5.8/6.6V,300mW,SO	11	SNA	
....4		0403-001785	DIODE-ZENER;NZH5V1B,4.94/5.2V,500mW,SOD-	1	SA	
....4	D0254	0404-001404	DIODE-SCHOTTKY;BAT721C,40V,200mA,SOT-23,	6	SA	
....4	T0139	0406-001200	DIODE-TVS;RCLAMP0504F,6/-V,150W,SC-70	1	SA	
....4	Q101	0501-000445	TR-SMALL SIGNAL;KTC3875S-Y,NPN,150mW,SOT	10	SA	
....4	CEQ2	0505-000110	FET-SILICON;2N7002,N,60V,115mA,7.5ohm,0.	7	SA	
....4	Q409	0505-002572	FET-SILICON;AO4801AL,P,-30V,-5.6A,0.075o	1	SA	
....4	U6	0801-002378	IC-CMOS LOGIC;74VHC04,INVERTER,SOP,14P,8	1	SA	
....4	ND51C2	0801-002780	IC-CMOS LOGIC;74LVC1G17,SCHMITT-TRIGGER	1	SA	
....4	IC106	1001-001573	IC-VIDEO SWITCH;Sil9287BCNUTR,QFN,72P,10	1	SNA	
....4		1006-001266	IC-LINE TRANSCEIVER;3232,TSSOP,16P,174MI	1	SA	
....4	IC112	1103-000129	IC-EEPROM;24C02,2Kbit,256x8,SOP,8P,5x4mm	2	SA	
....4	IC112	1103-001385	IC-EEPROM;AT24C256,256Kbit,32Kx8,SOP,8P,	1	SA	
....4		1105-002058	IC-DDR2 SDRAM;K4T1G164QE-HCF8,DDR2,1Gbit	2	SA	
....4	T0085	1201-002849	IC-AUDIO AMP;DRV603,TSSOP,14P,5x4.4mm,DU	1	SA	
....4	T0124	1201-002992	IC-POWER AMP;STA369BWS,PSSO,36P,10.3x7.5	1	SA	
....4	T0124	1201-002993	IC-POWER AMP;TAS5715,HTQFP,48P,7x7mm,DUA	1	SA	
....4	T0087	1203-002835	IC-POSI.FIXED REG.;KIA7805AF,DPAK,3P,6.6	1	SA	
....4	T0087	1203-005134	IC-POSI.FIXED REG.;RT9167A-33PB,SOT-23-5	1	SNA	
....4		1203-005559	IC-BACKLIGHT DRIVER;MP3302DJ,TSOT23,5P,2	1	SA	
....4		1203-006017	IC-VOL. DETECTOR;RT9824GJ8,TSOT23,8P,2.9	1	SA	
....4		1203-006104	IC-DC/DC CONVERTER;MP8707EN,SOIC8E,8P,4.	1	SA	
....4		1203-006127	IC-DC/DC CONVERTER;MP28253EL,QFN,14P,3x4	1	SA	
....4	T0087	1203-006136	IC-POSI.FIXED REG.;AP1117D-18-GZ-13-89,T	1	SA	
....4	IC012	1203-006138	IC-POSI.ADJUST REG.;AP1117DGZ-13-89,TO-2	1	SA	
....4		1204-003089	IC-DEMODULATOR;DRX39XYJ,PQFN,64P,9x9x0.8	1	SA	

## 5. Exploded View &amp; Part List

Level	Location No.	Code No.	Description & Specification	Q'ty	SA/SNA	Remark
....4		1204-003096	IC-VIDEO DECODER;HIDTVPRO-SX,PBGA,580P,P	1	SA	
....4		1204-003141	IC-DEMODULATOR;LGDT1129,PBGA,49P,17x17x1	1	SA	
....4		1205-003201	IC-BUS SWITCH;TC7WB125FK,SSOP,8P,2x2.3mm	2	SA	
....4		1205-003733	IC-SWITCH;AP2191MPG-13,MSOP-8L-EP,8P,2.9	1	SA	
....4		1405-001185	VARISTOR;24Vdc,1.6x0.8x0.36mm,TP	1	SA	
....4		1405-001271	VARISTOR;20Vdc,5A,1.0x0.5x0.6mm,TP	26	SA	
....4	R512	2007-000107	R-CHIP;470Kohm,5%,1/10W,TP,1608	1	SA	
....4	ZR24	2007-000109	R-CHIP;1Mohm,5%,1/10W,TP,1608	1	SA	
....4	R105	2007-000138	R-CHIP;100ohm,5%,1/16W,TP,1005	31	SA	
....4	MR306	2007-000141	R-CHIP;2.2Kohm,5%,1/16W,TP,1005	13	SA	
....4	R319	2007-000143	R-CHIP;4.7Kohm,5%,1/16W,TP,1005	54	SA	
....4		2007-000146	R-CHIP;6.8Kohm,5%,1/16W,TP,1005	2	SNA	
....4		2007-000147	R-CHIP;8.2Kohm,5%,1/16W,TP,1005	1	SA	
....4	R104	2007-000148	R-CHIP;10Kohm,5%,1/16W,TP,1005	14	SA	
....4	R102	2007-000149	R-CHIP;12Kohm,5%,1/16W,TP,1005	6	SA	
....4	HDR9	2007-000152	R-CHIP;20Kohm,5%,1/16W,TP,1005	2	SNA	
....4	MR36	2007-000153	R-CHIP;22Kohm,5%,1/16W,TP,1005	6	SNA	
....4	AR43	2007-000155	R-CHIP;27Kohm,5%,1/16W,TP,1005	3	SA	
....4	MR13	2007-000157	R-CHIP;47Kohm,5%,1/16W,TP,1005	5	SNA	
....4	R123	2007-000159	R-CHIP;56Kohm,5%,1/16W,TP,1005	1	SA	
....4	DR39	2007-000162	R-CHIP;100Kohm,5%,1/16W,TP,1005	5	SA	
....4	R111	2007-000171	R-CHIP;0ohm,5%,1/16W,TP,1005	18	SA	
....4	R338	2007-000173	R-CHIP;22ohm,5%,1/16W,TP,1005	9	SA	
....4	UR23	2007-000174	R-CHIP;47ohm,5%,1/16W,TP,1005	3	SA	
....4	R726	2007-000695	R-CHIP;3.3ohm,5%,1/10W,TP,1608	2	SNA	
....4	R124	2007-000775	R-CHIP;33Kohm,5%,1/16W,TP,1005	3	SNA	
....4	DR37	2007-000932	R-CHIP;470ohm,5%,1/16W,TP,1005	4	SA	
....4	OTR1	2007-001292	R-CHIP;33ohm,5%,1/16W,TP,1005	6	SA	
....4	R326	2007-001325	R-CHIP;3.3Kohm,5%,1/16W,TP,1005	6	SNA	
....4		2007-001333	R-CHIP;18Kohm,5%,1/16W,TP,1005	1	SA	
....4	MR316	2007-002796	R-CHIP;510ohm,5%,1/16W,TP,1005	3	SA	
....4	PR24	2007-002970	R-CHIP;56ohm,5%,1/16W,TP,1005	1	SA	
....4	TR30	2007-007009	R-CHIP;75ohm,5%,1/16W,TP,1005	4	SNA	
....4		2007-007135	R-CHIP;18Kohm,1%,1/16W,TP,1005	2	SNA	
....4	DR4	2007-007142	R-CHIP;10Kohm,1%,1/16W,TP,1005	34	SA	
....4		2007-007156	R-CHIP;1ohm,5%,1/16W,TP,1005	3	SA	
....4		2007-007239	R-CHIP;31.6Kohm,1%,1/10W,TP,1608	1	SNA	
....4		2007-007315	R-CHIP;3.9Kohm,1%,1/16W,TP,1005	1	SNA	
....4		2007-007318	R-CHIP;1Kohm,1%,1/16W,TP,1005	6	SA	
....4		2007-007573	R-CHIP;330Kohm,1%,1/16W,TP,1005	1	SC	
....4		2007-007587	R-CHIP;3.6Kohm,1%,1/16W,TP,1005	1	SNA	
....4		2007-007766	R-CHIP;2Kohm,1%,1/16W,TP,1005	1	SA	
....4	MR11	2007-008015	R-CHIP;75ohm,1%,1/16W,TP,1005	9	SA	
....4		2007-008136	R-CHIP;36Kohm,1%,1/16W,TP,1005	1	SA	
....4	R54	2007-008426	R-CHIP;12.4Kohm,1%,1/10W,TP,1608	1	SNA	
....4	DAR09	2011-001262	R-NETWORK;22ohm,5%,1/16W,L,CHIP,8P,TP,2.	6	SA	
....4		2011-001427	R-NETWORK;0ohm,5%,1/16W,L,CHIP,8P,TP,2.0	4	SA	
....4		2011-001449	R-NETWORK;22ohm,5%,1/16W,L,4P,TP,1010	5	SA	
....4		2011-001519	R-NETWORK;33OHM,5%,1/16W,L,CHIP,4P,TP,1.	5	SA	
....4		2011-001527	R-NETWORK;4.7Kohm,5%,1/16W,L,CHIP,4P,TP,	2	SA	
....4	C24	2203-000041	C-CER,CHIP;0.01nF,0.25pF,50V,C0G,1608	2	SA	

Level	Location No.	Code No.	Description & Specification	Q'ty	SA/SNA	Remark
....4	AC1	2203-000125	C-CER,CHIP;1.2nF,10%,50V,X7R,TP,1608,-	1	SA	
....4	AD480	2203-000204	C-CER,CHIP;100nF,10%,25V,X7R,2012	4	SNA	
....4	PC43	2203-000233	C-CER,CHIP;0.1nF,5%,50V,C0G,TP,1005	5	SA	
....4	MC302	2203-000425	C-CER,CHIP;.018nF,5%,50V,C0G,TP,1005	7	SA	
....4	C254	2203-000438	C-CER,CHIP;1nF,10%,50V,X7R,TP,1005	5	SA	
....4	C507	2203-000489	C-CER,CHIP;2.2nF,10%,50V,X7R,TP,1005	3	SA	
....4	V1233	2203-000575	C-CER,CHIP;220nF,10%,25V,X7R,TP,2012	7	SA	
....4	MC9	2203-000627	C-CER,CHIP;.022nF,5%,50V,C0G,TP,1005	2	SNA	
....4	AD480	2203-000679	C-CER,CHIP;0.027nF,5%,50V,C0G,1005	3	SA	
....4	AD480	2203-000714	C-CER,CHIP;3.3nF,10%,50V,X7R,TP,1005,-	2	SA	
....4	CK40B	2203-000838	C-CER,CHIP;0.39nF,5%,50V,C0G,TP,1608	2	SA	
....4	KAC5	2203-001126	C-CER,CHIP;0.68nF,10%,50V,X7R,1608	1	SNA	
....4	AD480	2203-001412	C-CER,CHIP;0.03nF,5%,50V,NP0,TP,1005	8	SNA	
....4	AD480	2203-001428	C-CER,CHIP;470nF,10%,50V,X7R,TP,2012	2	SA	
....4	AD480	2203-002285	C-CER,CHIP;10nF,10%,50V,X7R,1005	14	SNA	
....4	AD480	2203-002525	C-CER,CHIP;0.56nF,10%,50V,X7R,TP,1005	6	SA	
....4	C33	2203-002687	C-CER,CHIP;1.2nF,10%,50V,X7R,TP,1005	4	SA	
....4	AD480	2203-002994	C-CER,CHIP;0.068nF,5%,50V,CH,BK,1005	2	SNA	
....4	DC108	2203-005005	C-CER,CHIP;100nF,10%,16V,X7R,1608	2	SC	
....4	AAC1	2203-005249	C-CER,CHIP;100nF,10%,50V,X7R,TP,1608	12	SA	
....4	AD480	2203-005344	C-CER,CHIP;22nF,10%,25V,X7R,TP,1005,-	1	SNA	
....4	AD480	2203-005968	C-CER,CHIP;4.7nF,10%,50V,X7R,TP,1005	3	SNA	
....4	AD480	2203-006126	C-CER,CHIP;47nF,10%,16V,X7R,1005	3	SNA	
....4	PC11	2203-006141	C-CER,CHIP;1000nF,10%,16V,X5R,1608	3	SNA	
....4	C102	2203-006158	C-CER,CHIP;100nF,10%,16V,X7R,1005	176	SA	
....4	AD480	2203-006307	C-CER,CHIP;1000nF,10%,25V,X5R,2012	1	SNA	
....4	JC10	2203-006324	C-CER,CHIP;2200nF,10%,10V,X5R,1608	2	SA	
....4	AD480	2203-006336	C-CER,CHIP;10000nF,10%,25V,X5R,3216	10	SA	
....4	C125	2203-006361	C-CER,CHIP;10000nF,10%,10V,X5R,TP,2012	43	SC	
....4	HE4	2203-006474	C-CER,CHIP;22000nF,20%,6.3V,X5R,2012	16	SA	
....4	AD480	2203-006841	C-CER,CHIP;1000nF,10%,16V,X5R,1005	17	SNA	
....4	AD480	2203-007176	C-CER,CHIP;10000nF,10%,16V,X5R,TP,2012	2	SNA	
....4	C	2402-001326	C-AL,SMD;220uF,20%,16V,LZ,8.3x8.3x6.2mm	1	SA	
....4	T0052	2703-000158	INDUCTOR-SMD;1uH,10%,2012	4	SA	
....4	VL6	2703-000398	INDUCTOR-SMD;10uH,10%,3225	1	SA	
....4	L1103	2703-000403	INDUCTOR-SMD;22uH,10%,3225	1	SA	
....4	T0052	2703-001239	INDUCTOR-SMD;3.3uH,10%,1608	4	SA	
....4	T0052	2703-002332	INDUCTOR-SMD;330nH,5%,1608	1	SA	
....4	T0052	2703-003150	INDUCTOR-SMD;4.7uH,20%,5050	4	SNA	
....4	T0052	2703-003362	INDUCTOR-SMD;4.7uH,20%,7070	1	SA	
....4	T0052	2703-003637	INDUCTOR-SMD;22uH,20%,7070	1	SA	
....4	T0052	2703-003790	INDUCTOR-SMD;4.7uH,20%,8080	1	SA	
....4	X202	2801-003326	CRYSTAL-SMD;24MHz,30ppm,28-ABX,20pF,50oh	1	SA	
....4	X202	2801-003773	CRYSTAL-SMD;12MHz,30ppm,28-AAN,20pF,50oh	1	SA	
....4	X202	2801-004004	CRYSTAL-SMD;20.25MHz,20ppm,28-AAN,13pF,2	1	SA	
....4	XU25	2806-001308	OSCILLATOR-VCXO;27MHZ,-,30PF,TP,3.3V,50M	1	SA	
....4	F103	2901-001506	FILTER-EMI SMD;5V,0.13A,0pF,2x1x0.5mm,TP	2	SA	
....4	DR32	3301-000314	BEAD-SMD;120ohm,1.6x0.8x0.8mm,-,-,-	6	SNA	
....4	T0568	3301-001236	BEAD-SMD;60ohm,1608	2	SNA	
....4	T0568	3301-001404	BEAD-SMD;30ohm,2012,TP,15.9OHM/30MHz	8	SA	
....4	T0568	3301-002039	BEAD-SMD;26ohm,1608,TP	36	SA	

## 5. Exploded View &amp; Part List

Level	Location No.	Code No.	Description & Specification	Q'ty	SA/SNA	Remark
....4		3701-001591	CONNECTOR-HDMI;19P,2ROW,FEMALE,SMD-S,AU	2	SA	
....4		3701-001693	CONNECTOR-HDMI;19P,2ROW,FEMALE,SMD-A	1	SA	
....4	AC510	3708-001150	CONNECTOR-FPC/FFC/PIC;30P,1mm,SMD-A,SN,Y	1	SA	
....4	CON_US	3711-005616	HEADER-BOARD TO CABLE;BOX,10P,1R,2mm,SMD	1	SNA	
....4	HB01A	3711-007336	HEADER-BOARD TO CABLE;BOX,4P,1R,2.5mm,SM	1	SA	
....4	T0077	BN41-01385A	PCB MAIN;ATSC Hotel LC450,FR-4,4,1.2T,19	1	SNA	
....4		BN68-02775A	LABEL-SMD;ALL MODELS,8.5,21,COMMON	1	SNA	
....4		BN97-04224A	ASSY MICOM-MAIN;T-TDT5HUSC-1002.0,2010.0	1	SNA	
.....5		1107-001818	IC-NAND FLASH;KFG1G16U2C-DIB6,1024Mbit,6	1	SNA	
.....5		BN68-02303A	LABEL-IC;9.5MMX8MM,ART PAPER	1	SNA	
....4		BN97-04225A	ASSY MICOM-SUB;T-TDT5HUSS-8004,2010.04.2	1	SNA	
.....5	IC520	0903-001590	IC-MICROCONTROLLER;61P8E-RG480WT,LQFP,48	1	SNA	
....4	T0596	0904-002554	IC-USC;AU6256-JBF,QFN,28P,5x5mm,12MHz,TP	1	SA	
....4		2007-001237	R-CHIP;910ohm,1%,1/10W,TP,1608	1	SNA	
....4		2007-001285	R-CHIP;5.6ohm,5%,1/16W,TP,1005	2	SA	
....4	KFC6	2203-000872	C-CER,CHIP;0.0030nF,0.25pF,50V,C0G,1608	2	SNA	
....4	T0052	2703-002268	INDUCTOR-SMD;8.2nH,5%,1005	2	SNA	
....4	X202	2801-004775	CRYSTAL-SMD;12MHz,30ppm,16pF,30ohm,TP	1	SNA	
....4	HR3	2007-000903	R-CHIP;430ohm,1%,1/10W,TP,1608	1	SNA	
....4		2007-002768	R-CHIP;6.2Kohm,1%,1/10W,TP,1608	1	SA	
....4		1203-004363	IC-VOL. DETECTOR;RT9818C-29PV,SOT-23,3P,	1	SA	
....4	T0087	1203-002898	IC-POSI.FIXED REG.;G950T45R,T0-252,3P,6.	1	SA	
...3		0201-002251	ADHESIVE-EPOXY;UNIQUE 6200,BLACK/YELLOW,	1	SNA	
0.1		BN91-05848A	ASSY SHIELD;LN32C450E1GXZA	1	SNA	
..2	T0081	6001-002284	SCREW-MACHINE;BH,+,M4,L8,ZPC(WHT),SWRCH1	7	SA	
..2	T0081	6001-002604	SCREW-MACHINE;BH,+,M4,L10,ZPC(WHT),SWRCH	2	SA	
..2	M0081	6003-000337	SCREW-TAPTYPE;BH,+,S,M4,L10,ZPC(BLK),SWR	6	SA	
..2	M0081	6003-001003	SCREW-TAPTYPE;BH,+,B,M4,L12,ZPC(BLK),SWR	7	SA	
..2	M2893	BN39-01267A	LEAD CONNECTOR;LA32B450,UL 2651 AWG#26,1	1	SA	
..2	M2893	BN39-01274A	LEAD CONNECTOR;LC5F,UL 1007 #26,14P,80mm	1	SA	
..2	T0764	BN44-00338B	DC VSS-LCD TV;P2632HD_ADY,P2632HD_ADY,AC	1	SA	
..2	M0254	BN61-06066A	HOLDER-SIDE AV;LC550,PC+ABS,V0,BK0008	1	SNA	
..2		BN61-06441A	HOLDER-INLET;LC530,ABS,V0	1	SNA	
..2	CCMM1	BN73-00264A	SILICON/RUBBER;LE32C530F1WXXC,SILICON+PO	2	SNA	
..2	M0523	BN96-12973A	ASSY BRACKET P-WALL;32,37,40,LC650,SECC,	4	SNA	
...3	T0101	BN61-05996A	BRACKET-WALL;LC650 40,SECC,T1.2	4	SNA	
...3		BN60-00188B	SPACER-FOAM;LCD,FELT,20,3.0,20,Center :	4	SNA	
..2	M0230	BN96-13227A	ASSY CABLE P-FFC;LA32C450,FFC,1mm PITCH,	1	SA	
..2	T0910	BN96-13341A	ASSY BRACKET P-STAND LINK;LC530 32,SECC,	1	SA	
...3		BN61-02429K	STUD-PEM;PNB,M3.8,D7,L14.9,ZPC(SIL),SUM2	4	SNA	
...3	M0115	BN61-06024A	BRACKET-STAND LINK;LC550 32",SECC,T1.2	1	SNA	
...3		BN61-05281A	HOLDER-CLAMP;LCD,NYLON 66,WHT	2	SNA	
0.1		BN92-05530Q	ASSY BOX;LC450 32	1	SNA	
..2		BN69-04612K	BOX-SET;32LC450,CB,A-01,SW2,YEL,W1008,D1	1	SNA	
..2		BH68-00662A	LABEL BOX-00;ALL MODEL,MOJO 90G,60,110,W	1	SNA	
0.1		BN92-06033A	ASSY LABEL;LA32C450E1TXXT	1	SNA	
..2	T0527	BP68-00052B	LABEL-00,RATING;CCTV,TETRON PAPER,T0.05,	1	SNA	
0.1		BN92-06488A	ASSY P/MATERIAL;LC450 32,SWIVEL	1	SNA	
..2	T0214	0203-001595	TAPE-OPP MASKING;OPP-2,0.075,75,800M,CLR	2.32	SNA	
..2	T0524	6902-000519	BAG PE;HDPE/NITRON,T0.015/T0.05(DOUBLE),	1	SNA	
..2	M040	6922-000013	BAND PP;PP,W18,L2300m,TRP,21000g	0.99	SNA	

Level	Location No.	Code No.	Description & Specification	Q'ty	SA/SNA	Remark
..2		BH69-00418A	BAG WRAPPING;LDPE,762,1828M,SAMEX FACTOR	0.9	SNA	
..2		BH69-40321C	PACKING INNER-00,PAD;COMM,CB,2030,140,CG	1	SNA	
..2		BN68-02422B	LABEL-WARNING SHIPPING;ALL MODEL,A/P 100	1	SNA	
..2		BN69-05034B	PAD CUSHION;32LC***,EPS,T50,W435,D360	1	SNA	
..2		BN69-05139A	CUSHION-SET;LC459 32",EPS	1	SNA	
0.1	ACCE1	BN92-06501A	ASSY ACCESSORY;LN32C459E1GXZA	1	SNA	
..2	ACCE1	BN96-13543A	ASSY ACCESSORY;LN32C459E1GXZA	1	SNA	
...3	T0268	<a href="#">3903-000467</a>	CBF-POWER CORD;DT,US,EP3,IEC320 C13-RA,1	1	SA	
...3	T0120	4301-000121	BATTERY-MN;1.5V,R03,10.5x44.5m,HOLDER,7.	2	SNA	
...3	T0524	6902-000018	BAG PE;LDPE,T0.1,W280,L400,CLEAR,8,2,20.	1	SNA	
...3		AA68-03242L	MANUAL FLYER-07,SAFETY GUIDE;comm,Samsun	1	SNA	
...3		BN39-00865B	CBF IF-MODULAR/MODULAR;US HOTEL CORAL,6P	1	SA	
...3		BN39-01011C	CBF IF-MODULAR/MODULAR;US HOTEL CORAL/AM	1	SA	
...3	T0074	BN59-01068A	REMOCON;TM1050,SAMSUNG,20PIN SINGLE,49KE	1	SA	
...3	M9889	<a href="#">BN63-01798B</a>	CLOTH-CLEAN;cloth,180,200,sea blue,ToC	1	SA	
...3	RB01	BN63-07208A	COVER-BOTTOM;C450 32inch,HIPS,V0	1	SA	
...3	T0527	BN68-00513A	LABEL-E,PASS;ALL MODEL,YUPO(110G),50X15,	1	SNA	
...3	T0059	BN68-02178C	MANUAL FLYER-CARD;COMM,SAMSUNG,eng/spa/c	1	SNA	
...3		BN68-03013A	MANUAL FLYER-QSG;LN32C450E1G LN32C459E1G	1	SNA	
...3		BN96-10788C	ASSY ACCESSORY-PREVENT;LCD-TV,32,37,40,n	1	SNA	
0.1	R001A	BN90-02857K	ASSY COVER REAR;LC450 32	1	SNA	
..2	M0081	6003-001003	SCREW-TAPTYPE;BH,+ ,B,M4,L12,ZPC(BLK),SWR	9	SA	
..2	M0013	BN96-12737H	ASSY COVER P-REAR;LC450 32,UO(HOTEL),PCM	1	SA	
...3	AH358	BN61-06544A	HOLDER-REAR;LC650 32,PP,BLK	1	SNA	
...3		BN64-01270P	INLAY-AV;LC530/531/532/533,KO,PS SHEET,T	1	SNA	
...3	T0071	BN64-01312A	INLAY-TERMINAL;LC530,PS SHEET,T0.5,UO HO	1	SNA	
...3	T0139	BN65-00003A	CLAMPER BAG;42C7,LDPE,HB,BLK	1	SNA	
...3	M0006	BN63-06392A	COVER-REAR;32,LCD-TV,UO,KO,PCM T0.5,BLK	1	SNA	
...3	M0131	BN63-04082A	GASKET;PS63P71FHX,CONDUCTIVE ADHESIVE sp	1	SNA	
...3	M0131	BN63-03845A	GASKET;EMT4-10-4-110R-DM8,4T,10MM,100MM	2	SNA	
...3		BN60-00162C	SPACER-FOAM;FOAM,50000mm,Dark Gray,0.5T,	0.86	SNA	

## 6. Wiring Diagram

### 6-1. Wiring Diagram

- C539 : 37"
- C450/C459 : 26",32"

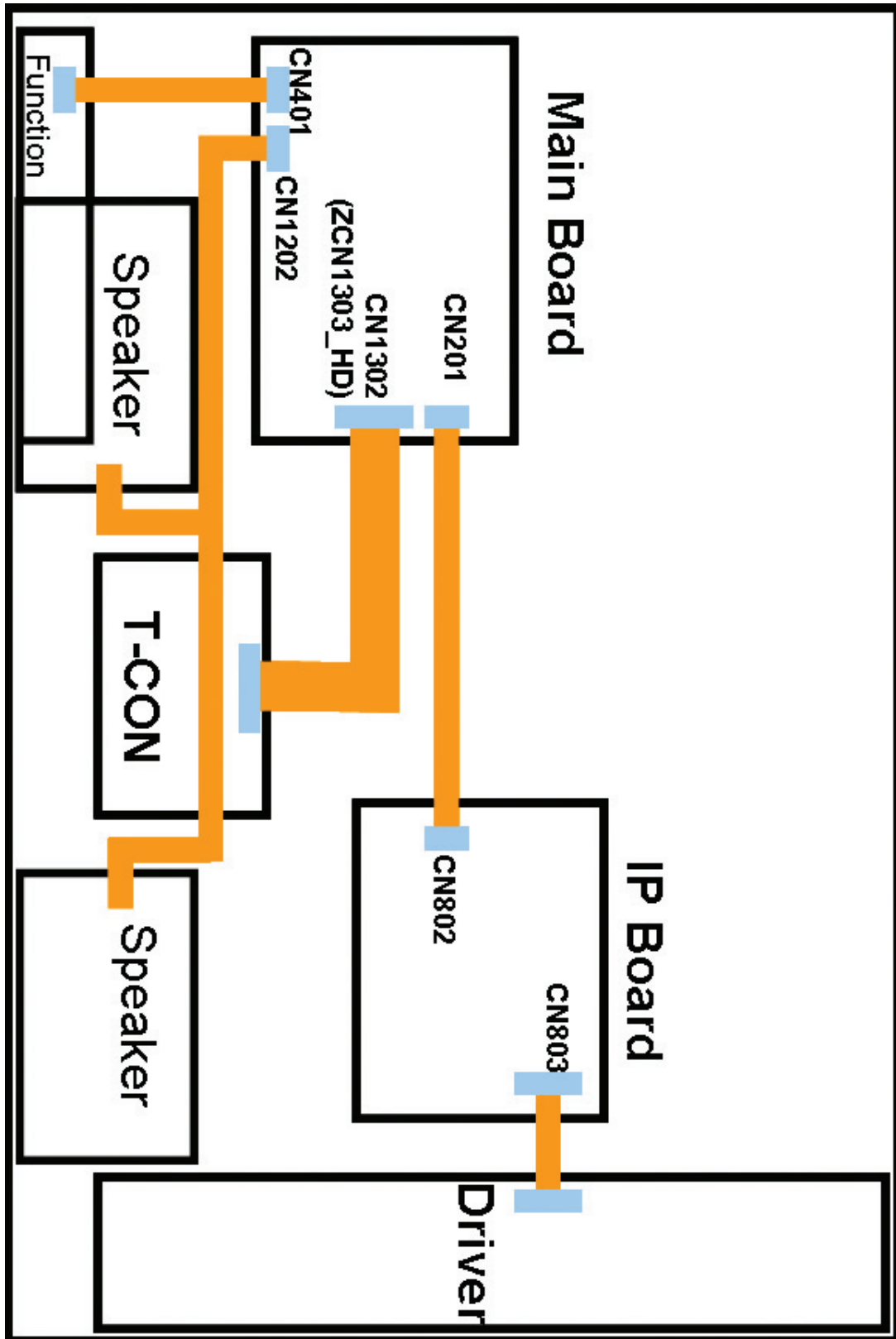

■ C530/C539 : 40", 46"

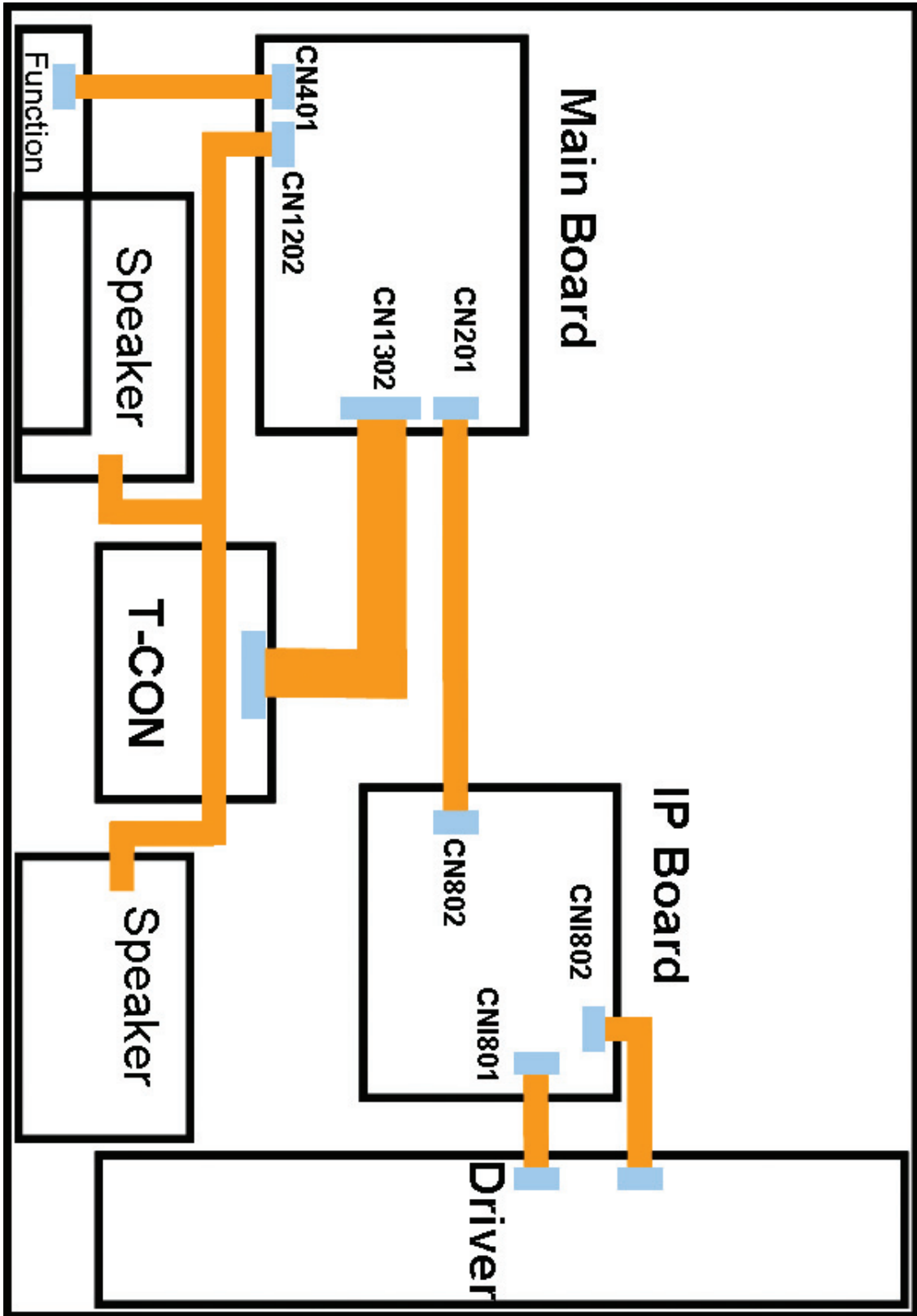

## 6-2. Connector

<b>FCN402 (to Panel) C550/C540(40"/46")/C530</b>			
1	NC	27	EVEN[0]-
2	NC	28	GND
3	NC	29	ODD[4]+
4	NC	30	ODD[4]-
5	NC	31	ODD[3]+
6	NC	32	ODD[3]-
7	FORMAT	33	GND
8	SDA_Panel	34	ODDCLK+
9	TCON_WP	35	ODDCLK-
10	NC	36	GND
11	SDA_Panel	37	ODD[2]+
12	SCL_Panel	38	ODD[2]-
13	GND	39	ODD[1]+
14	EVEN[4]+	40	ODD[1]-
15	EVEN[4]-	41	ODD[0]+
16	EVEN[3]+	42	ODD[0]-
17	EVEN[3]-	43	GND
18	GND	44	GND
19	EVENCLK+	45	GND
20	EVENCLK-	46	NC
21	GND	47	Panel_VCC
22	EVEN[2]+	48	Panel_VCC
23	EVEN[2]-	49	Panel_VCC
24	EVEN[1]+	50	Panel_VCC
25	EVEN[1]-	51	Panel_VCC
26	EVEN[0]+		

<b>ZCN1303_HD(to Panel) C540(32")/C450</b>			
1	Panel_VCC	16	ODD[CLK]+
2	Panel_VCC	17	ODD[CLK]-
3	Panel_VCC	18	GND
4	Panel_VCC	19	ODD[2]+
5	Panel_VCC	20	ODD[2]-
6	GND	21	GND
7	GND	22	ODD[1]+
8	GND	23	ODD[1]-
9	TCON_WP	24	GND
10	FORMAT	25	ODD[0]+
11	NC	26	ODD[0]-
12	GND	27	GND
13	ODD[3]+	28	SDA_TCON
14	ODD[3]-	29	SCL_TCON
15	GND	30	NC

<b>CN202 (to Powr board)</b>			
1	B12VS	10	GND
2	SW_POWER	11	GND
3	B12VS	12	H_OUT
4	A5V	13	B13V
5	B5V	14	PWM_DIMMING
6	B5V	15	B13V
7	B5V	16	SW_INVERTER
8	GND	17	B13V
9	GND	18	IP_DET

<b>CN401(FUNCTION)</b>			
1	IR	6	KEY_INPUT1
2	GND	7	KEY_INPUT2
3	A5V	8	LED_STB
4	MSCL	9	FUNC_9
5	MSDA	10	LED_CONTROL

<b>CN501(LAN) C550</b>			
1	LAN_TX-	5	LAN_VCC
2	GND	6	LAN_RX-
3	LAN_TX+	7	NC
4	LAN_RX+	8	GND

<b>CN901(PC)</b>			
1	PC_RED	9	PC_5V
2	PC_GREEN	10	IDENT_PC
3	PC_BLUE	11	R_FANET
4	T_FANET	12	SDA_DOWN
5	GND	13	PC_HS
6	GND	14	PC_VS
7	GND	15	SCL_DOWN
8	GND		

<b>CN902(PC/DIV SOUND)</b>			
1	GND	4	NC
2	PC_SR_IN	5	NC
3	PC_SL_IN	6	NC

<b>CN903(DEBUG)</b>			
1	GND	4	DEBUG_TX
2	DEBUG_RX	5	DEBUG_TX
3	DEBUG_TX	6	GND

<b>CN701(UNIVERSAL JACK)</b>			
1	GND	16	GND
2	COM2_SL	17	COMP1_SL
3	COM2_SR	18	COMP1_SR
4	GND	19	GND
5	COMP2_SR	20	COMP1_SR
6	COMP2_SL	21	COMP1_SL
7	GND	22	GND
8	COMP2_PR	23	COMP1_PR
9	COMP2_PR	24	COMP1_PR
10	GND	25	GND
11	COMP2_PB	26	IDENT_COMP1
12	COMP2_PB	27	COMP1_PB
13	GND	28	GND
14	IDENT_COMP2	29	IDENT_AV
15	COMP2_Y	30	COMP1_Y

<b>CN1202 (SPEAKER)</b>			
1	R+	3	L+
2	R-	4	L-

<b>CN705_2U (REAR USB) C550</b>			
1	USB_VCC	3	USB_DP
2	USB_DM	4	GND

<b>CN706 (SIDE USB)</b>			
1	USB_VCC	3	USB_DP
2	USB_DM	4	GND

<b>CN704 (SIDE AV) C550/C540/C30</b>			
1	GND	6	SL_IN
2	IDENT_AV	7	GND
3	CVBS	8	SL_IN
4	GND	9	SR_IN
5	SR_IN		

<b>CN1002 (HDMI1)</b>			
1	HDMI1_RX2+	11	GND
2	GND	12	HDMI1_RXCLK-
3	HDMI1_RX2-	13	HDMI_CEC
4	HDMI1_RX1+	14	GND
5	GND	15	SCL
6	HDMI1_RX1-	16	SDA
7	HDMI1_RX0+	17	GND
8	GND	18	5V
9	HDMI1_RX0-	19	HPD
10	HDMI1_RXCLK+		

<b>CN1003 (HDMI2)</b>			
1	HDMI2_RX2+	11	GND
2	GND	12	HDMI2_RXCLK-
3	HDMI2_RX2-	13	HDMI_CEC
4	HDMI2_RX1+	14	GND
5	GND	15	SCL
6	HDMI2_RX1-	16	SDA
7	HDMI2_RX0+	17	GND
8	GND	18	5V
9	HDMI2_RX0-	19	HPD
10	HDMI2_RXCLK+		

<b>CN1004 (HDMI3) C550/C540</b>			
1	HDMI3_RX2+	11	GND
2	GND	12	HDMI3_RXCLK-
3	HDMI3_RX2-	13	HDMI_CEC
4	HDMI3_RX1+	14	GND
5	GND	15	SCL
6	HDMI3_RX1-	16	SDA
7	HDMI3_RX0+	17	GND
8	GND	18	5V
9	HDMI3_RX0-	19	HPD
10	HDMI3_RXCLK+		



<b>CN1001 (SIDE HDMI4)</b>			
1	HDMI4_RX2+	11	GND
2	GND	12	HDMI4_RXCLK-
3	HDMI4_RX2-	13	HDMI_CEC
4	HDMI4_RX1+	14	GND
5	GND	15	SCL
6	HDMI4_RX1-	16	SDA
7	HDMI4_RX0+	17	GND
8	GND	18	5V
9	HDMI4_RX0-	19	HPD
10	HDMI4_RXCLK+		

<b>CN1201 (MONITOR OUT)</b>			
1	GND	5	NC
2	OUT_R	6	GND
3	OUT_R	7	NC
4	GND		

### 6-3. Connector Functions

Connector	Functions
Main CN201 ↔ IP CN802	Supply main power and dimming signal from IP board to Main Board.
Main CN1302/ZCN1303_HD ↔ T-CON CNF1	The LVDS signal transferred from Main Board to Panel .
IP CN803 ↔ Panel CN1 (14 Pin)	Supply power from IP board to Driver Board.
IP CNI802 ↔ Panel CN1 (2 Pin)	Supply power from IP board to Driver Board.
IP CNI801 ↔ Panel CN3 (7 Pin)	Supply power from IP board to Driver Board.

### 6-4. Cables

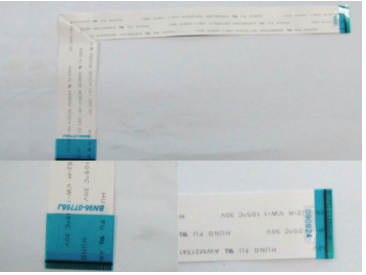
Use	LEAD (Main-IP 18P)	LVDS (Main - TCON)	
<b>Code</b>	37" C539 : BN39-01267C(300mm) 40" C530/C539 : BN39-01267E(250mm) 46" C539 : BN39-01267F(350mm) 26" C450/C459 : BN39-01267B(150mm) 32" C450/C459 : BN39-01267A(200mm)	37" C550/C530 : BN96-07612X 40" C530/C539 : BN96-07613Y 46" C539 : BN96-07614Z	26" C450/C459 : BN96-07766J 32" C450/C459 : BN96-07766K
<b>Photo</b>			
<b>Use</b>	LEAD (IP-Driver B'D 14P)	LEAD (IP-Driver B'D 2P)	LEAD (IP-Driver B'D 7P)
<b>Code</b>	37" C539 : BN39-01272A(100mm) 26" C450/C459 : BN39-01274A(80mm) 32" C450/C459 : BN39-01274A(80mm)	40" C530/C539 : BN39-01024D(200mm) 46" C539 : BN39-01021B(250mm)	40" C530/C539 : BN39-00830B(200mm) 46" C539 : BN39-01279A(250mm)
<b>Photo</b>	