

INSTALLATION INSTRUCTIONS FOR EXPOSED SLOAN WATER CLOSET AND URINAL FLUSHOMETERS



Closet Flushometer for 1½” Top Spud

- MODELS 110/111, 113, 114, 115 & 116

Service Sink Flushometer for 1½” Top Spud

- MODEL 117



Urinal Flushometer for ¼” Top Spud

- MODEL 180

Urinal Flushometer for ¾” Top Spud

- MODEL 186



Closet Flushometer for 1½” Back Spud

- MODELS 120, 121 & 122

LIMITED WARRANTY

Unless otherwise noted, Sloan Valve Company warrants this product, manufactured and sold for commercial or industrial uses, to be free from defects in material and workmanship for a period of three (3) years (one (1) year for special finishes, SF faucets, PWT electronics and 30 days for PWT software) from date of first purchase. During this period, Sloan Valve Company will, at its option, repair, replace, or refund the purchase price of any product which fails to conform with this warranty under normal use and service. This shall be the sole and exclusive remedy under this warranty. Products must be returned to Sloan Valve Company, at customer's cost. No claims will be allowed for labor, transportation or other costs. This warranty extends only to persons or organizations who purchase Sloan Valve Company's products directly from Sloan Valve Company for purpose of resale. This warranty does not cover the life of the batteries.

THERE ARE NO WARRANTIES WHICH EXTEND BEYOND THE DESCRIPTION ON THE FACE HEREOF. IN NO EVENT IS SLOAN VALVE COMPANY RESPONSIBLE FOR ANY CONSEQUENTIAL DAMAGES OF ANY MEASURE WHATSOEVER.

PRIOR TO INSTALLATION

Before you install the Sloan Flushometer, be sure the items listed below are installed. Also, refer to the rough-in diagram below.

- Closet fixture
- Drain line
- Water supply line

IMPORTANT:

- **ALL PLUMBING SHOULD BE INSTALLED IN ACCORDANCE WITH APPLICABLE CODES AND REGULATIONS.**
- **WATER SUPPLY LINES MUST BE SIZED TO PROVIDE AN ADEQUATE VOLUME OF WATER FOR EACH FIXTURE.**
- **FLUSH ALL WATER LINES PRIOR TO MAKING CONNECTIONS.**

The Sloan Flushometer is designed to operate with 15 to 80 psi (103 to 552 kPa) of water pressure. **THE MINIMUM PRESSURE REQUIRED TO THE VALVE IS DETERMINED BY THE TYPE OF FIXTURE SELECTED.** Consult fixture manufacturer for minimum pressure requirements. Most High Efficiency water closets require a minimum flowing pressure of 25 psi (172 kPa). Many building codes and the ASME A112.19.2 fixture standard list Maximum static water pressure as 80 PSI (552 kPa).

TOOLS REQUIRED FOR INSTALLATION

- Straight blade screwdriver
- Sloan A-50 Super-Wrench™, Sloan A-109 Plier Wrench or smooth jawed spud wrench

!!! IMPORTANT !!!

PROTECT THE FINISH OF SLOAN FLUSHOMETERS – DO NOT USE TOOTHED TOOLS TO INSTALL OR SERVICE THESE VALVES. USE A SLOAN A-50 SUPER-WRENCH™, SLOAN A-109 PLIER WRENCH OR SMOOTH JAWED SPUD WRENCH TO SECURE ALL COUPLINGS. ALSO SEE “CARE AND CLEANING” SECTION OF THIS MANUAL.

!!! IMPORTANT !!!

WITH THE EXCEPTION OF CONTROL STOP INLET, DO NOT USE PIPE SEALANT OR PLUMBING GREASE ON ANY VALVE COMPONENT OR COUPLING!

!!! IMPORTANT !!!

THIS PRODUCT CONTAINS MECHANICAL AND/OR ELECTRICAL COMPONENTS THAT ARE SUBJECT TO NORMAL WEAR. THESE COMPONENTS SHOULD BE CHECKED ON A REGULAR BASIS AND REPLACED AS NEEDED TO MAINTAIN THE VALVE'S PERFORMANCE.

If you have questions about how to install your Sloan flushometer, consult your local Sloan Representative or call Sloan Technical Support at:

1-888-SLOAN-14 (1-888-756-2614)

ROUGH-IN

MODEL 110/111

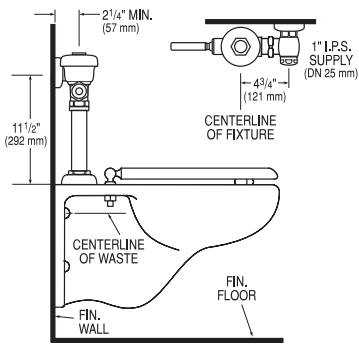

MODELS 113, 114, 115 & 116

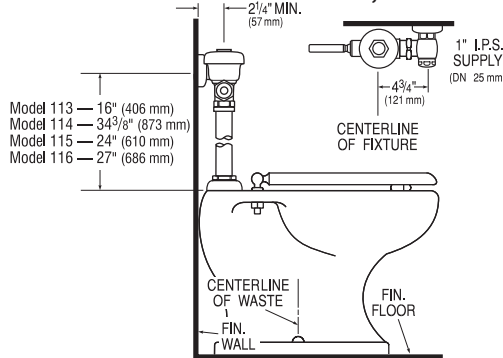

MODEL 117

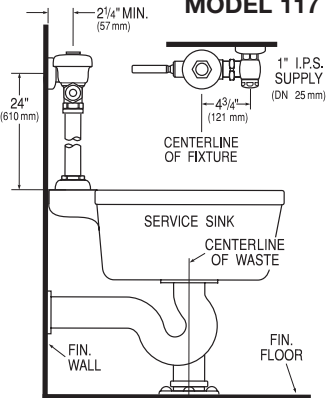

MODELS 120, 121, & 122

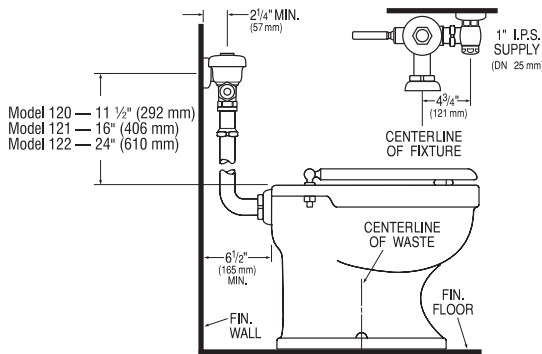

MODEL 180

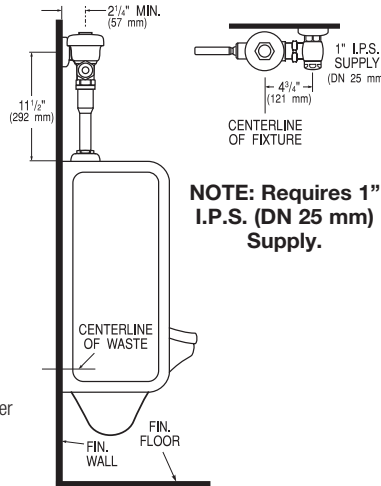

MODEL 186

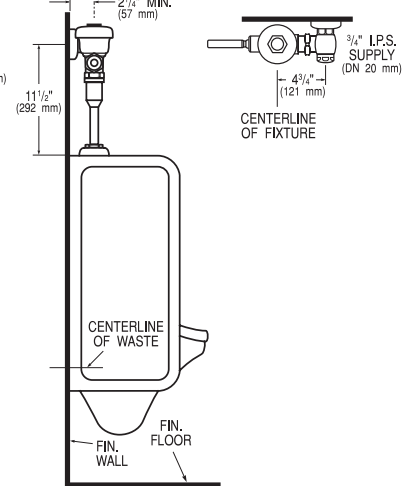

NOTE: Requires 1" I.P.S. (DN 25 mm) Supply.

IMPORTANT NOTES:

- When mounted on an ADA accessible bowl, the rough-in to the supply inlet should be no higher than 37 1/2" or the handle will exceed maximum height allowances under ADA guidelines.
- New ADAAG Guidelines allow for Split or Offset Grab Bars, check with local authorities or reference section 604.5.2 of ADAAG.

1 - INSTALL OPTIONAL SWEAT SOLDER ADAPTER (ONLY IF YOUR SUPPLY PIPE DOES NOT HAVE A MALE THREAD)

A Measure from finished wall to C/L of fixture spud. Cut pipe 1" (32 mm) shorter than this measurement. Chamfer O.D. and I.D. of water supply pipe.

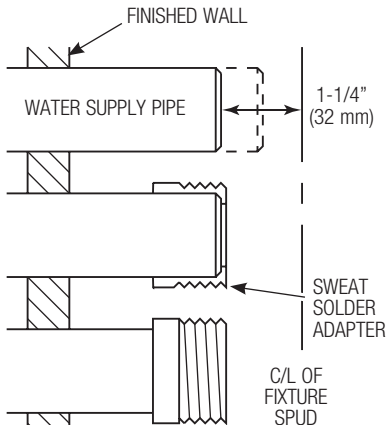

B Slide threaded adapter fully onto pipe.

C Sweat solder the adapter to pipe.

!!! IMPORTANT !!!
WITH THE EXCEPTION OF CONTROL STOP INLET, DO NOT USE PIPE SEALANT OR PLUMBING GREASE ON ANY VALVE COMPONENT OR COUPLING!

2 - INSTALL COVER TUBE, WALL FLANGE AND CONTROL STOP TO SUPPLY PIPE

A Measure from finished wall to first thread of adapter or threaded supply pipe (dimension "X"). Cut cover tube to this length.

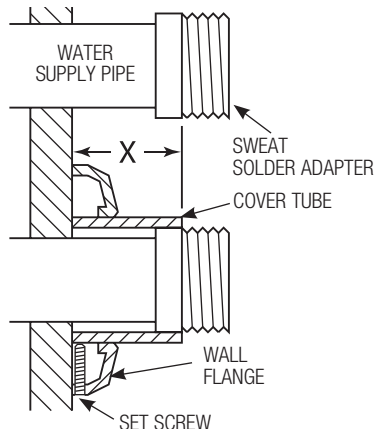

B Slide cover tube over pipe. Slide wall flange over cover tube until against wall.

C Thread control stop onto pipe. Tighten with a wrench.

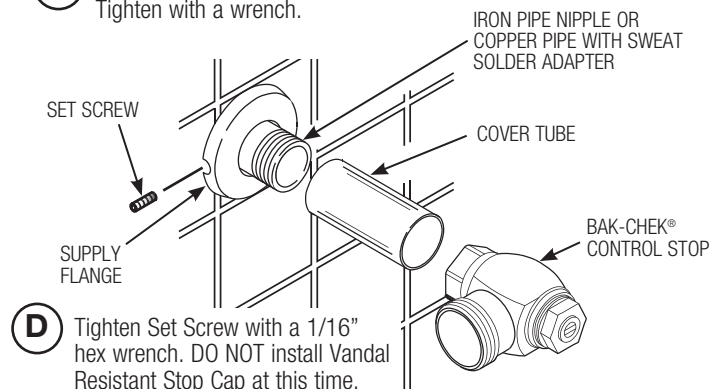

D Tighten Set Screw with a 1/16" hex wrench. DO NOT install Vandal Resistant Stop Cap at this time.

3 - INSTALL VACUUM BREAKER FLUSH CONNECTION

MODELS 110/111,
113, 114, 115,
116, 117

MODELS 120, 121, 122

MODEL 180

MODEL 186

- A** Slide spud coupling, nylon slip gasket, rubber gasket and spud flange over vacuum breaker tube.
- B** Insert tube into fixture spud.
- C** Hand tighten spud coupling onto fixture spud.

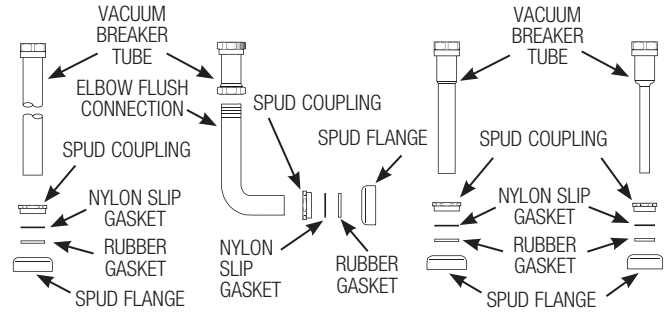

4 - INSTALL FLUSHOMETER

NOTE

For high efficiency urinal flushometers (0.5, 0.25 and 0.125 gpf), it is necessary to first insert the flow control component into the tailpiece assembly. See the H1015A flow control kit and separate instructions for details on how to install.

- A** Lubricate tailpiece o-ring with water. Insert adjustable tailpiece into control stop. Tighten tailpiece coupling by hand.
- B** Align flushometer directly above the vacuum breaker flush connection by sliding the flushometer Body IN or OUT as needed. Tighten vacuum breaker coupling by hand.

NOTE

Maximum adjustment of the Sloan Adjustable Tailpiece is 1/2" (13 mm) IN or OUT from the standard 4-3/4" (121 mm) (centerline of Flushometer to centerline of Control Stop).

If roughing-in measurement exceeds 5-1/4" (133 mm), consult factory for longer tailpiece.

- C** Align flushometer body and securely tighten first the tailpiece coupling (1), then the vacuum breaker coupling (2), and finally the spud coupling (3). Use a wrench to tighten these couplings in the order shown.

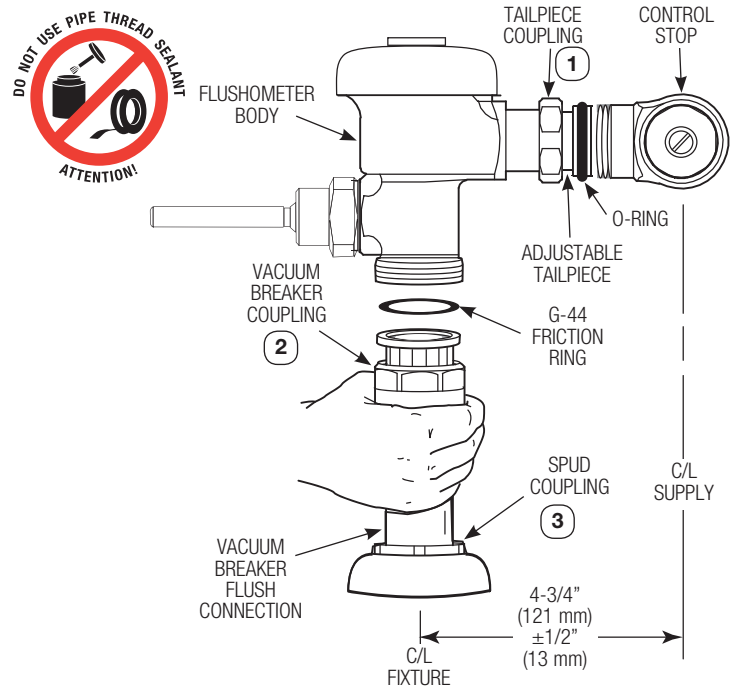

5 - FLUSH OUT SUPPLY LINE

- A** Make sure control stop is CLOSED and remove flushometer outer cover.
- B** Remove inside cover and lift out inside parts assembly.

- C** Reinstall outside and inside cover wrench tight. Open control stop to flush supply line. Close control stop and remove outside and inside cover.
- D** Reinstall inside parts assembly, inside cover and outside cover wrench tight.

6 - ADJUST CONTROL STOP AND INSTALL VANDAL RESISTANT STOP CAP

- A** Open control stop COUNTERCLOCKWISE one FULL turn from closed position.
- B** Activate flushometer.

- C** Adjust control stop after each flush until the rate of flow delivered properly cleanses the fixture.
- D** Install vandal resistant control stop cap onto control stop.

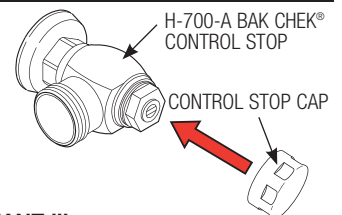

!!! IMPORTANT !!!

Sloan's flushometers are engineered for quiet operation. Excessive water flow creates noise, while too little water flow may not satisfy the needs of the fixture. Proper adjustment is made when plumbing fixture is cleansed after each flush without splashing water out from the lip AND a quiet flushing cycle is achieved.

TROUBLESHOOTING

1. Valve does not function (no flush).

- A. Control stop or main valve is closed. Open control stop or main valve.
- B. Handle assembly is worn or damaged. Install handle repair kit or replace handle assembly.
- C. Relief valve is worn or damaged. Replace inside parts kit.

2. Volume of water is not sufficient to siphon fixture.

- A. Control stop is not open wide enough. Adjust control stop for desired delivery of water volume.
- B. Urinal flushometer parts inside a closet flushometer. Replace inside urinal Parts with proper closet flushometer parts.
- C. Low consumption flushometer installed on a higher consumption fixture. Replace inside parts kit with water saver kit.
- D. Water saver kit installed in old non-water saver bowl. Position refill head so that SIDE 1 is in the UP position.
- E. Water supply volume or pressure is inadequate. If no gauges are available to properly measure supply pressure or volume of water at the flushometer, then remove the relief valve from the inside parts kit, reassemble the flushometer and completely open the control stop.
 - If the fixture siphons, more water volume is required. If a 3.5 gpf inside parts kit is installed in the flushometer, then first flip the refill head (under the diaphragm) to obtain a 4.5 gpf volume. If this volume is still inadequate, remove the flow ring from the guide to obtain a 6.5 gpf kit. If additional flow is required, try a low pressure guide kit. **IMPORTANT – LAWS AND REGULATIONS PROHIBIT THE USE OF HIGHER FLUSHING VOLUMES THAN LISTED ON FIXTURE OR FLUSHOMETER.**
 - If the fixture does not siphon or if a low consumption fixture is installed, or if the above steps do not prove satisfactory, steps must be taken to increase the water supply pressure and/or volume. Contact the fixture manufacturer for minimum water supply requirements of the fixture.

3. Flushometer closes off immediately.

- A. Ruptured or damaged diaphragm. Replace inside parts kit.
- B. Enlarged by-pass orifice from corrosion or damage. Replace inside parts kit.

4. Length of flush is too short (short flush).

- A. Diaphragm assembly and guide assembly are not hand-tight. Screw the two assemblies hand-tight.
- B. Enlarged by-pass orifice from corrosion or damage. Replace inside parts kit.

- C. Urinal flushometer parts inside a closet flushometer. Replace inside urinal parts with proper closet flushometer parts.
- D. Low consumption flushometer installed on a higher consumption fixture. Replace inside parts kit with water saver kit.
- E. Handle assembly is damaged. Replace Handle

5. Length of flush is too long (long flush) or continuous.

- A. Relief valve is not seating properly or by-pass orifice is clogged because of foreign material, or by-pass orifice is closed by an invisible gelatinous film from "over-treated" water. Disassemble the working parts and wash thoroughly. **NOTE: Size of the orifice in the by-pass is of utmost importance for the proper metering of water into the upper chamber of the flushometer. Do not enlarge or damage this orifice.** Replace inside kit if cleaning does not correct problem.
- B. Supply line water pressure has dropped and is not sufficient to close the valve. Close control stop until pressure is restored.
- C. Closet flushometer parts inside a urinal flushometer. Replace inside closet parts with proper urinal flushometer parts.
- D. Inside cover is damaged. Replace inside cover.

6. Chattering noise is heard during flush.

- A. The segment diaphragm is installed upside-down. Replace the segment diaphragm to the proper position as instructed by markings on the diaphragm.
- A. Inside cover is damaged. Replace inside cover.

7. Handle Leaks.

- A. Handle gasket, seal or assembly is damaged. Replace as required.

**If assistance is required, please contact
Sloan Technical Support at:
1-888-SLOAN-14 (1-888-756-2614)**

CARE AND CLEANING

DO NOT use abrasive or chemical cleaners (including chlorine bleach) to clean flushometers that may dull the luster and attack the chrome or special decorative finishes. Use ONLY mild soap and water, then wipe dry with clean cloth or towel.

While cleaning the bathroom tile, protect the flushometer from any splattering of cleaner. Acids and cleaning fluids will discolor or remove chrome plating.

PARTS LIST

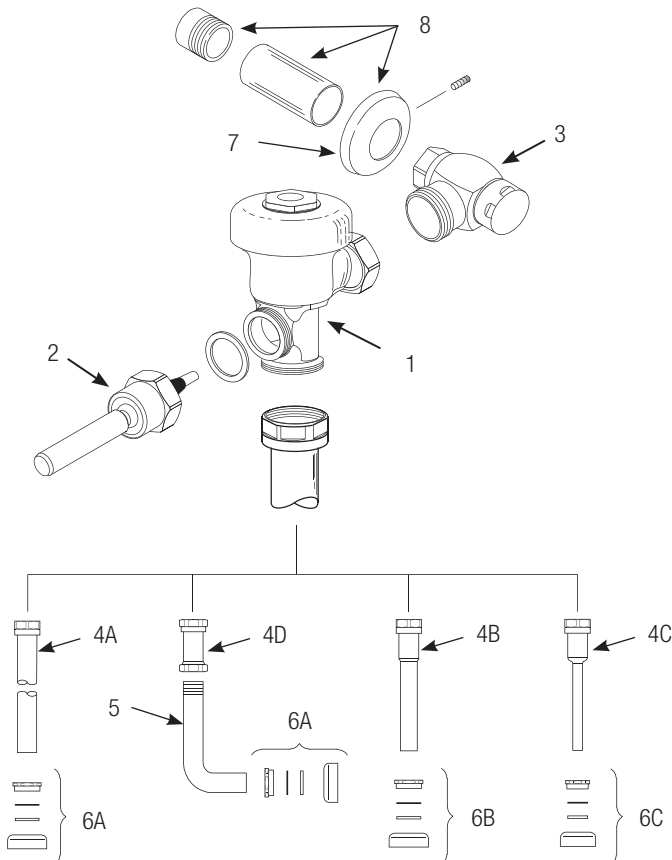

| Item No. | Part No. | Description |
|----------|----------|--|
| 1 | † | Valve Assembly |
| 2 | B-73-A | ADA Compliant Handle Assembly |
| 3 | H-710-A | Bak-Chek® Control Stop |
| 4A | V-500-AA | 1½" (38 mm) x 9" (229 mm) Vacuum Breaker Assembly ‡ |
| 4B | V-500-AA | 1¼" (32 mm) x 9" (229 mm) Vacuum Breaker Assembly |
| 4C | V-500-AA | ¾" (19 mm) x 9" (229 mm) Vacuum Breaker Assembly |
| 4D | V-500-A | Vacuum Breaker Assembly |
| 5 | F-109 | 1½" (38 mm) Elbow Flush Connection |
| 6A | F-56-A | 1½" (38 mm) Spud Coupling Assembly |
| 6B | F-57-A | 1¼" (32 mm) Spud Coupling Assembly |
| 6C | F-58-A | ¾" (19 mm) Spud Coupling Assembly |
| 7 | F-7 | Supply Flange (Supplied when Valve is not Ordered with Sweat Solder Kit) |
| 8 | H-633-AA | 1" (25 mm) Sweat Solder Kit with Cast Set Screw Flange |
| | H-636-AA | ¾" (19 mm) Sweat Solder Kit with Cast Set Screw Flange |
| † | | Part number varies with valve model variation; consult factory. |
| ‡ | | Length varies with valve model variation; consult factory. |

For optimum water conservation and flushometer performance, use only Genuine Sloan Parts.

NOTE: The information contained in this document is subject to change without notice.

SLOAN • 10500 SEYMOUR AVENUE • FRANKLIN PARK, IL 60131

Phone: 1-800-982-5839 • Fax: 1-800-447-8329 • www.sloanvalve.com