

INSTALLATION INSTRUCTIONS FOR RETROFIT AND COMPLETE SLOAN ECOS[®] VALVE INSTALLATION



8100 HET/HEU Complete Flushometer Models

8100 Series Sloan ECOS[®] Electronic Flush valves are complete Flushometer valves and ideal for new installations.

Reducing Your Water Footprint™



RESS Series Retrofit Conversion Kit Models

RESS Sloan ECOS[®] Electronic models are used to convert existing Royal, Sloan, and Regal style Flushometers to sensor operation.

Sloan ECOS[®] Electronic Dual Flush Water Closet & Urinal Models are furnished for the following:

- 1.6 gpf/1.1 gpf (6.0 Lpf/4.2 Lpf) For Low Consumption Bowls
- 1.28 gpf/1.1 gpf (4.8 Lpf/4.2 Lpf) For High Efficiency Bowls
- 0.5 gpf/1.9 Lpf For Washdown Urinals
- 0.25 gpf/1.9 Lpf For High Efficiency Urinals
- 0.125 gpf/1.9 Lpf For High Efficiency Urinals

SLOAN[®] LIMITED WARRANTY SUMMARY

Sloan Valve Company ("Sloan"), warrants its products against defects in materials and workmanship, excluding damage caused by matters beyond Sloan's reasonable control. Instructions for filing claims can be found in the Limited Warranty which can be obtained at www.Sloan.com or by requesting a free copy by telephone at 888.756.2614. Sloan will repair or replace your defective product, or provide a refund, as your exclusive remedy. This is only a general summary of Sloan's Limited Warranty so it is important to note that the specific terms, conditions, limitations and exclusions, including the duration of warranty coverage for your particular Sloan product, are contained in the actual Sloan Limited Warranty. The Limited Warranty is subject to applicable laws in your country, state, province or other jurisdiction—and disputes arising under the Limited Warranty are to be resolved by binding arbitration unless you provide Sloan with an opt-out notice no later than 30 days after your purchase date. In case of a conflict with this summary, the terms and conditions set forth in the complete Limited Warranty will prevail.

PRIOR TO INSTALLING THE SLOAN ECOS[®] DUAL-FLUSH ELECTRONIC FLUSHOMETER

Prior to installing the Sloan ECOS[®] Electronic Flushometer, install the items listed below as illustrated in the Rough-in Diagram. (New installations only.)

- Closet fixture
- Drain line
- Water supply line

Important:

- **ALL PLUMBING SHOULD BE INSTALLED IN ACCORDANCE WITH APPLICABLE CODES AND REGULATIONS.**
- **WATER SUPPLY LINES MUST BE SIZED TO PROVIDE AN ADEQUATE VOLUME OF WATER FOR EACH FIXTURE.**

- **WHEN INSTALLING A FLUSHOMETER, IT IS IMPORTANT THAT THE FLUSH MODEL MATCHES THE REQUIREMENTS OF THE PLUMBING FIXTURE.**
- **FLUSH ALL WATER LINES PRIOR TO MAKING CONNECTIONS.**

The Sloan ECOS[®] is designed to operate with 15 to 80 PSI (103 to 552 kPa) of water pressure.

THE MINIMUM PRESSURE REQUIRED TO THE VALVE IS DETERMINED BY THE TYPE OF FIXTURE SELECTED. Consult fixture manufacturer for pressure requirements.

Most High Efficiency water closets require a minimum flowing pressure of 25 psi (172 kPa). Many building codes and the ASME A112.19.2 fixture standard list Maximum static water pressure as 80 PSI (552 kPa).

TOOLS REQUIRED FOR INSTALLATION

- Slotted screwdriver to adjust control stop.
- Sloan A-50 Super-Wrench™, Sloan A-109 Plier Wrench or smooth jawed spud wrench for couplings.
- Trimpot adjustment screwdriver (supplied) to adjust range, if necessary.
- Strap wrench (supplied) to install Sloan ECOS[®] Electronic to valve body.
- 7/64" hex wrench (supplied) to secure Sloan ECOS[®] Electronic cover to base plate.

VALVE ROUGH-IN

Typical Water Closet Installation Model 8110/8111

Reference for RESS-C Retrofit

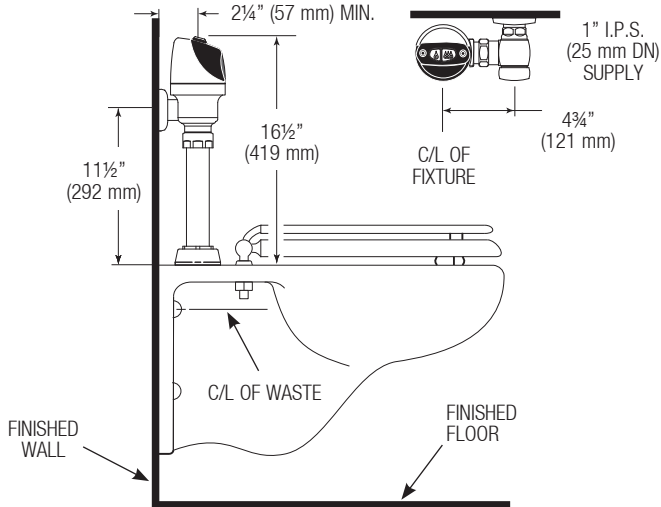

High Rough-in Water Closet Installation Models 8113, 8115 & 8116

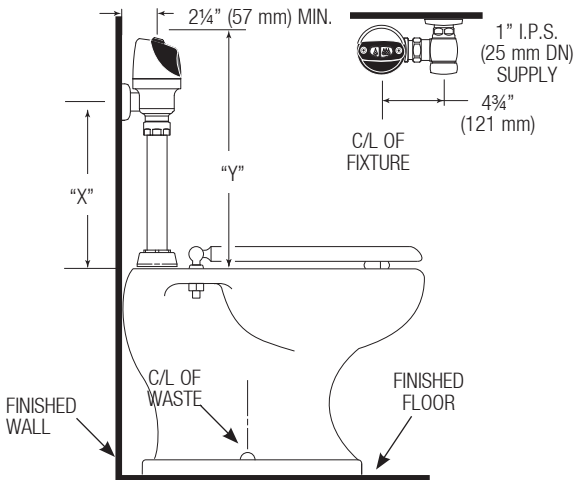

MODEL	"X"	"Y"
8113	16" (406 mm)	21" (533 mm)
8115	24" (610 mm)	29" (737 mm)
8116	27" (686 mm)	32" (813 mm)

Model 8115 & 8116 valves are designed for installations where the water supply is roughed-in 24" - 27" (610 mm - 686 mm) above the top of the water closet.

Typical Urinal Installation

Model 8186

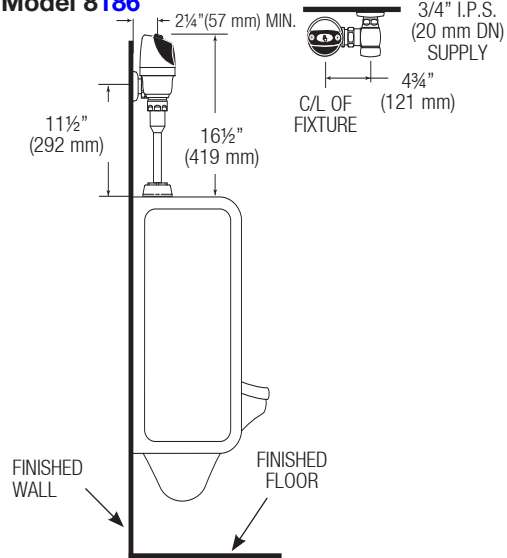

Squat Toilet Water Closet Installation Model 8137

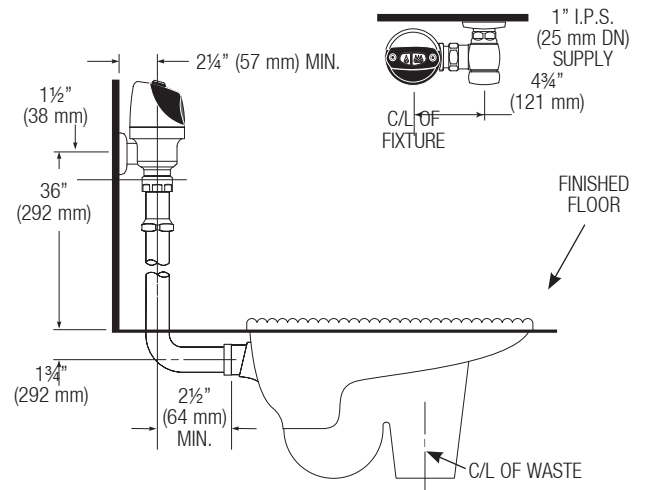

ALTERNATIVE WATER CLOSET INSTALLATION

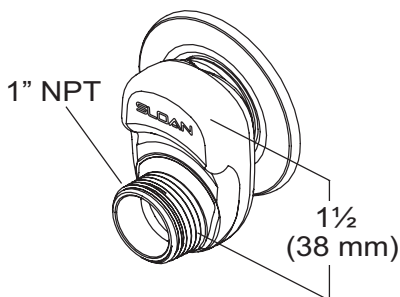

When installing the Sloan ECOS® Electronic Flushometer in an ADA compliant stall: Per ADA Guidelines (section 604.9.4) it is recommended that the grab bars be split or shifted to the wide side of the stall. For alternative installations, lower water supply rough-in to 10" (254 mm), or use the H-1018-A 1-1/2" offset adapter (not supplied) to lower the overall height. The Sloan H-1018-A 1" NPT x 1-1/2" offset adapter kit (sold separately) is designed to lower a ECOS Flushometer 1-1/2" when the space above the top of the Flushometer conflicts with grab bar clearance. Mount the grab bar at the 36" (914 mm) maximum allowed height (top of grab bar at 36").

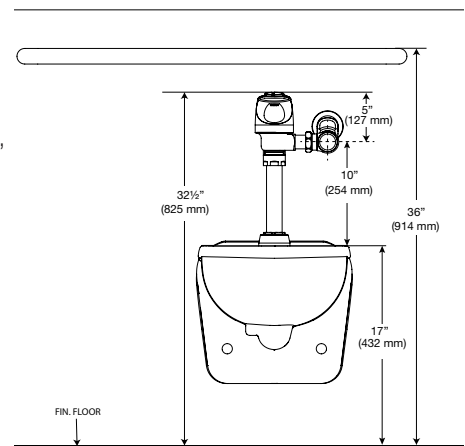

1 - FOR COMPLETE VALVE INSTALLATION, START HERE. FOR RESS RETROFIT INSTALLATIONS, START AT STEP 6. INSTALL OPTIONAL SWEAT SOLDER ADAPTER (ONLY IF YOUR SUPPLY PIPE DOES NOT HAVE A MALE THREAD).

- A** Measure from finished wall to C/L of Fixture Spud. Cut pipe 1¼" (32 mm) shorter than this measurement. Chamfer O.D. and I.D. of water supply pipe.
- B** Slide Threaded Adapter fully onto pipe.
- C** Sweat solder the Adapter to pipe.

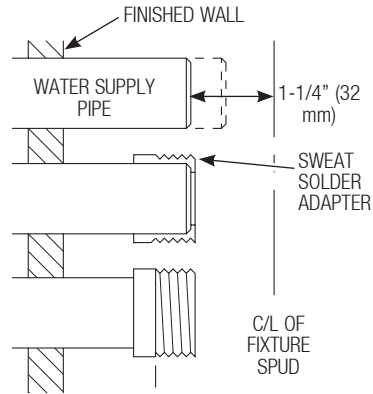

!!! IMPORTANT !!!
PROTECT THE CHROME OR SPECIAL FINISH OF SLOAN FLUSHMETERS — DO NOT USE TOOTHED TOOLS TO INSTALL OR SERVICE THESE VALVES. USE A SLOAN A-50 SUPER-WRENCH™, SLOAN A-109 PLIER WRENCH OR SMOOTH JAWED SPUD WRENCH TO SECURE ALL COUPLINGS. ALSO SEE “CARE AND CLEANING” SECTION

!!! IMPORTANT !!!
WITH THE EXCEPTION OF CONTROL STOP INLET, DO NOT USE PIPE SEALANT OR PLUMBING GREASE ON ANY VALVE COMPONENT OR COUPLING!

!!! IMPORTANT !!!
When further assistance is required, please contact your local Sloan Representative or call Sloan Technical Support at: 1-888-SLOAN-14 (1-888-756-2614)

!!! IMPORTANT !!!
THIS PRODUCT CONTAINS MECHANICAL AND/OR ELECTRICAL COMPONENTS THAT ARE SUBJECT TO NORMAL WEAR. THESE COMPONENTS SHOULD BE CHECKED ON A REGULAR BASIS AND REPLACED AS NEEDED TO MAINTAIN THE VALVE'S PERFORMANCE.

!!! IMPORTANT !!!
WITH THE EXCEPTION OF CONTROL STOP INLET, DO NOT USE PIPE SEALANT OR PLUMBING GREASE ON ANY VALVE COMPONENT OR COUPLING!

!!! IMPORTANT !!!
THE STRAP WRENCH PROVIDED WITH SLOAN ECOS® ELECTRONIC IS A CONVENIENCE TOOL AND IS NOT TO BE USED TO REMOVE OR INSTALL THE FLUSHMETER COUPLINGS. USE STRAP WRENCH ONLY TO INSTALL SLOAN ECOS® ELECTRONIC LOCKING RING.

2 - INSTALL COVER TUBE, WALL FLANGE AND CONTROL STOP TO SUPPLY PIPE

- A** Measure from finished wall to first thread of Adapter or threaded supply pipe (dimension "X"). Cut Cover Tube to this length.
- B** Slide Cover Tube over pipe. Slide Wall Flange over Cover Tube until against wall.
- C** Thread Control Stop onto pipe. Tighten with a wrench.
- D** Tighten Set Screw with a 1/16" hex wrench. DO NOT install Vandal Resistant Stop Cap at this time.

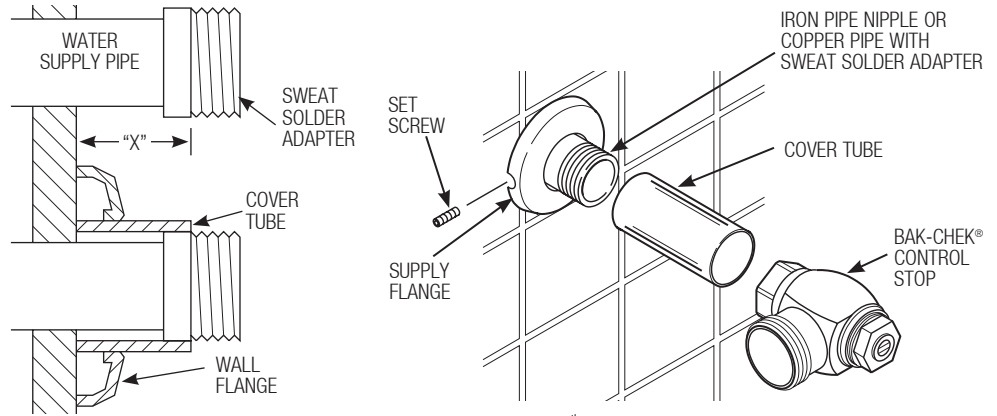

3 - FLUSH OUT SUPPLY LINE

- A** Open Control Stop.
- B** Turn on water supply to flush line of any debris or sediment.
- C** Close Control Stop.



4 - INSTALL VACUUM BREAKER FLUSH CONNECTION

NOTE

If cutting Vacuum Breaker Tube to size, note that Critical Line (C/L) on Vacuum Breaker must typically be 6" (152 mm) above fixture. Consult Code for details.

- A** Slide Spud Coupling, Nylon Slip Gasket, Rubber Gasket and Spud Flange over Vacuum Breaker Tube.
- B** Insert Tube into Fixture Spud.
- C** Hand tighten Spud Coupling onto Fixture Spud.

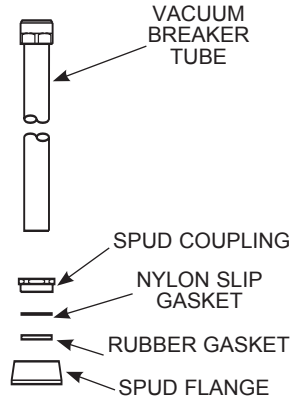

5 - INSTALL FLUSHOMETER

- A** Lubricate tailpiece O-ring with water. Insert Adjustable Tailpiece into Control Stop. Tighten Tailpiece Coupling by hand.
- B** Align Flushometer directly above the Vacuum Breaker Flush Connection by sliding the Flushometer Body IN or OUT as needed. Tighten Vacuum Breaker Coupling by hand.

NOTE

Maximum adjustment of the Sloan Adjustable Tailpiece is 1/2" (13 mm) IN or OUT from the standard 4-3/4" (121 mm) (centerline of Flushometer to centerline of Control Stop).

If roughing-in measurement exceeds 5-1/4" (133 mm), consult factory for longer tailpiece.

- C** Align Flushometer Body and securely tighten first the Tailpiece Coupling (1), then the Vacuum Breaker Coupling (2), and finally the Spud Coupling (3). Use a wrench to tighten these couplings in the order shown.

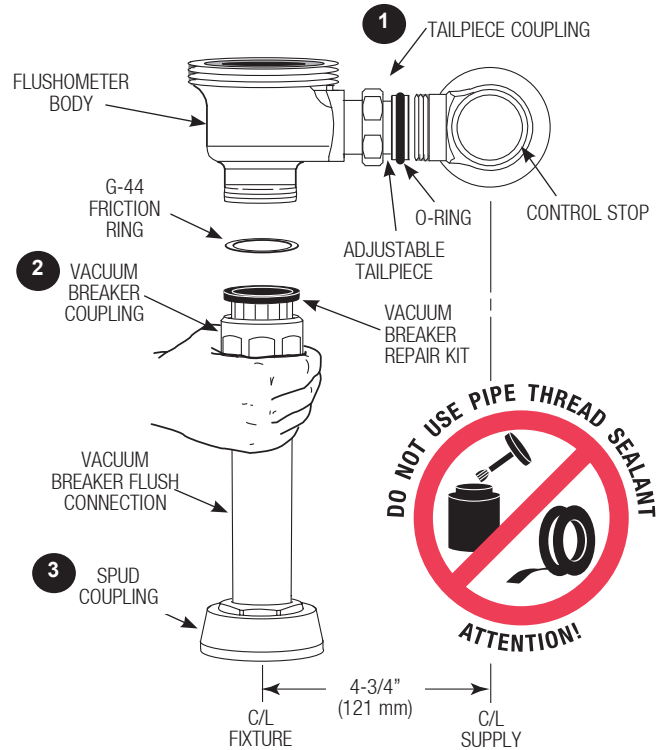

6 - WHEN RETROFITTING AN EXISTING VALVE, START HERE. REMOVE COMPONENTS FROM EXISTING FLUSHOMETER (RESS RETROFIT INSTALLATIONS ONLY)

- A** Remove Control Stop Cap.
- B** Turn off water supply at Control Stop. Push Valve Handle to relieve water pressure.
- C** Remove Outside and Inside Covers and old Inside Parts Kit.
- D** Remove old Handle Assembly and Gasket.
- E** Install Chrome Handle Cap with Gasket to handle opening on Flushometer Body. Tighten Chrome Handle Cap securely.

NOTE: An extra H-553 Tail O-ring is included in the event leakage occurs if the valve is repositioned during the installation of the new Sloan ECOS® Electronic. Use only as needed.

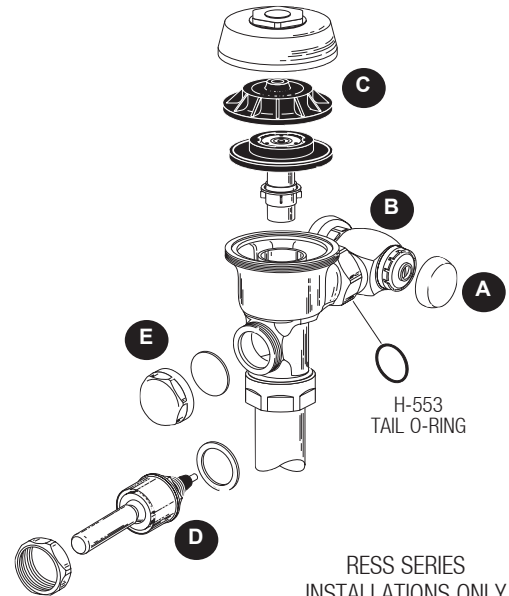

7 - SLOAN ECOS® ELECTRONIC DUAL-FLUSH VOLUMES (RESS RETROFIT INSTALLATIONS ONLY)

The Dual-Flush Volume of the Sloan ECOS® Electronic is controlled by the Flex Tube Diaphragm Kit. Regulators are identified by color.

RESS-C Sloan ECOS® Electronic valves are supplied with it's lowest flush volume configuration.

When installing a new Regulator on a Flex Tube Diaphragm Kit, be sure to push the Regulator past the O-ring when installing.

Note: Never use more water than needed. Low Consumption water closets will not function properly on excess water.

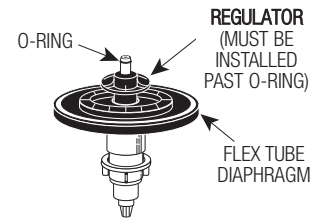

8 - ASSEMBLE FLEX TUBE DIAPHRAGM TO SLOAN ECOS® DUAL-FLUSH ELECTRONIC ASSEMBLY

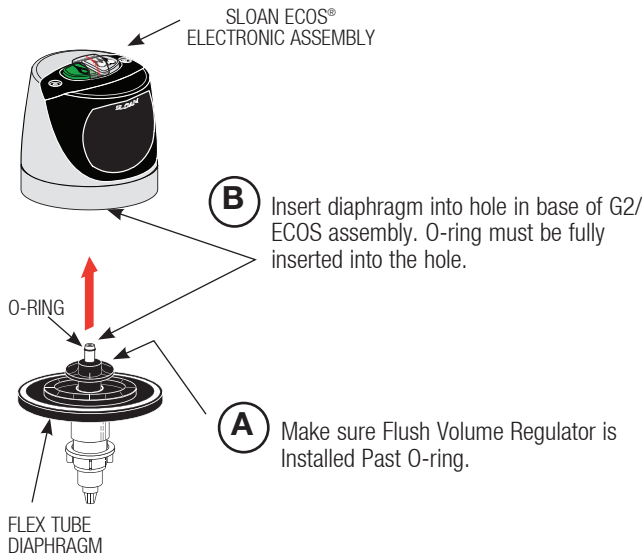

C Push Diaphragm securely against underside of Sloan ECOS® Electronic Assembly. Place entire Assembly onto the Valve Body.

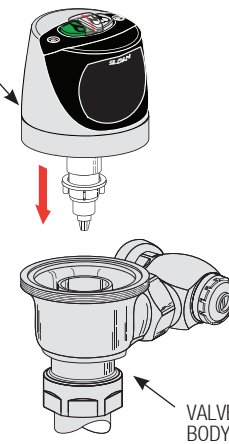

To facilitate installation, the O-ring on the diaphragm assembly must be wet for easier insertion. NOTE: Sensor Lens must face directly forward. Rotating the Sensor to either side will decrease the Sensor's ability to detect a target.

9 - TIGHTEN LOCKING RING

A Thread Locking Ring onto Valve Body.

B Use Strap Wrench provided to tightly secure Locking Ring.

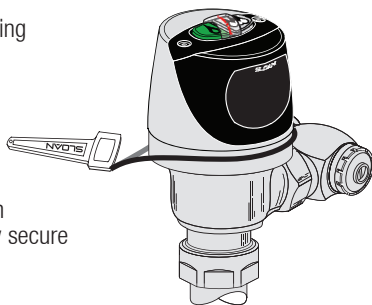

!!! IMPORTANT !!!

The Locking Ring must be installed down past the valve body threads by at least one thread. If difficulty is experienced installing the Locking Ring, turn the Locking Ring back and forth, each time working it further down the threads. The Locking Ring will act as a thread chaser in the event there has been a build-up of matter on the threads of the old valve body.

If retrofitting the Optima Plus onto a †Zurn valve body, a special Locking Ring must be used (identified by a machined groove around the ring).

Order the Optima Plus with the "Z" variation to receive the unit supplied with this Ring.

10 - REMOVE TAB TO ACTIVATE SENSOR MODULE

A Remove all removable objects in sensor view area and remove the Tab located over the Override Button to activate the Sensor Module. The sensor module will perform the start-up routine for one minute with LED blinking.

B After the start-up routine is complete, for the first ten (10) minutes of operation, a Visible LED Light flashes in the Sensing Window of the Optima Plus Flushometer when a user is detected.

NOTE

The self adaptive sensor automatically adapts to the surrounding environment when the tab on the override button is removed.

No manual adjustments are required. Start-up mode will take approximately one (1) minute to complete its cycle and it is important that no non-permanent target is present at this time. If the target is permanent, the sensor will adapt itself around this target. A 3 seconds long LED light on and followed with slow LED light blinking in sensor window indicates sensor is in the start-up mode. When the start-up cycle is complete, one LED light blink indicates lithium batteries are installed and two LED light blinks indicates alkaline batteries are installed.

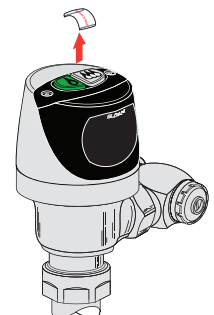

†The brands and/or products names referenced herein may be subject to trademark rights of their respective owners. Use of the brands and names is for identification purposes only and does not imply affiliation with or endorsement by Sloan.

11 - TEST SENSOR OPERATION

The ECOS has a factory set sensing range:

Water Closet Models - 22" to 42" (559 mm to 1067 mm)

Urinal Models - 15" to 30" (381 mm to 762 mm)

The factory setting should be satisfactory for most installations. If a range adjustment is required, refer to the Range Adjustment instructions on this page.

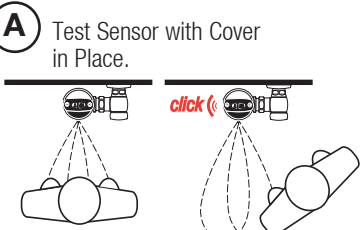
- A** Test Sensor with Cover in Place.
- B** Stand in front of Sensor for eight (8) seconds
- C** Step away from Sensor and listen for "CLICK."
- *16 seconds-BT Water Closet Models
- 

12 - ADJUST CONTROL STOP AND INSTALL VANDAL RESISTANT STOP CAP

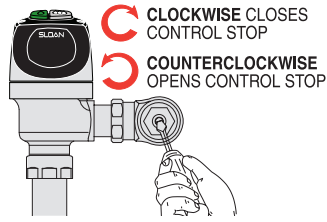
- A** Open Control Stop COUNTERCLOCKWISE ½ turn from closed position.
- B** Activate Flushometer by placing hand in front of Optima Plus Sensor Lens for 8-16 seconds and then moving it away (or press override button).
- C** Adjust Control Stop after each flush until the rate of flow delivered properly cleanses the fixture.
- 

!!! IMPORTANT !!!

The flushometer is engineered for quiet operation. Excessive water flow creates noise, while too little water flow may not satisfy the needs of the fixture. Proper adjustment is made when plumbing fixture is cleaned after each flush without splashing water out from the lip AND a quiet flushing cycle is achieved.

!!! IMPORTANT !!!

The Control Stop should never be opened to the point where the flow from the valve exceeds the flow capability of the fixture. In the event of a valve failure, the fixture must be able to accommodate a continuous flow from the valve.

- D** Install Control Stop Cap onto Control Stop. For RESS retrofit applications, reuse Stop Cap from existing valve. In complete valve installations, a new Stop Cap is provided. For G2 models, follow the instructions packaged with the Free Spinning Vandal Resistant Stop Cap.

13 - OPERATION

1. A continuous, INVISIBLE light beam is emitted from the Sloan ECOS® Electronic



- Sensor.
2. As the user enters the beam's effective range, water closets 22 to 42 inches (559 mm to 1067 mm), the beam is reflected into the Scanner Window to activate the Output Circuit. Once activated, the Output Circuit continues in a "hold" mode for as long as the user remains within the effective range of the sensor. If the user stays longer than 65 seconds, a full flush will automatically initiate when the user



- leaves.
3. Once a user is detected, if the user leaves in 65 seconds or less, a reduced flush will automatically initiate. The circuit automatically resets and is ready for the next user.

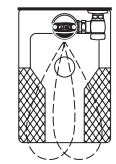
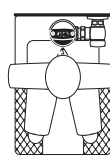
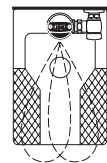

14 - RANGE ADJUSTMENT (ADJUST ONLY IF NECESSARY)

The ECOS has a factory set sensing range:

Water Closet Models - 22" to 42" (559 mm to 1067 mm)

Urinal Models - 15" to 30" (381 mm to 762 mm)

The Factory setting should be satisfactory for most installations.

If the range is too short (i.e., not picking up users) or too long (i.e., picking up opposite wall or stall door) the range can be adjusted.

Note: Water does not have to be turned off to adjust range.

Make sure to remove all the non-permanent targets in sensor view area. Push manual override button for 20-30 seconds. the LED in the sensor starts slow blinking. Release the button during the LED blinking (for BT models, press manual override again for 20-30 seconds). The ECOS will enter into distance setting mode. The setting mode will run for one minute.

NOTE: To automatically check battery strength, troubleshoot, diagnose and report issues with a wireless device, use the Sloan SmartPhone APP. The APP is available free-of-charge at the Apple iPhone APP store for iOS devices or the Google Play APP store for Android devices. For more information about the APP and its capabilities please visit Sloan.com.

To communicate with your flushometer, wave your hand 3 times in front of sensor within 10 seconds to activate your product or press and hold the override button for 12 seconds.

*-BT compatible models only



!!! IMPORTANT !!!

WHEN ADJUSTING RANGE FOR URINAL SENSOR, MAKE SURE TO SET-UP A PROPER TARGET IN FRONT OF URINAL SENSOR.

When further assistance is required, please contact Sloan Technical Support at: +1.888.SLOAN.14 (+ 1.888.756.2614) or visit us online at: sloan.com

15- BATTERY REPLACEMENT

When required, replace batteries with four (4) AA-Size Batteries. **Note: Water does not have to be turned off to replace Batteries.** Loosen the two (2) Screws on top of unit. Remove the complete Cover Assembly. Lift the Sensor Module from its Plate. Unplug the Electrical Connector from Battery Compartment Cover. Loosen the Retaining Screw on Battery Compartment Cover and remove Battery Compartment Cover.

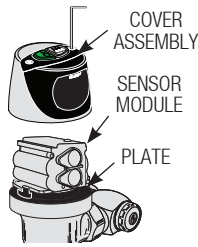

Install four (4) AA-Size Batteries exactly as illustrated. Install Battery Compartment Cover and secure with Retaining Screw. Make certain that Battery Compartment Cover is fully compressed against Gasket to provide a seal; Do Not overtighten. Plug the Electrical Connector into the Battery Compartment Cover. Reinstall the Sensor Module onto the Plate. Reinstall the complete Cover Assembly onto the Plate. Tighten the two (2) Screws on top of the unit.

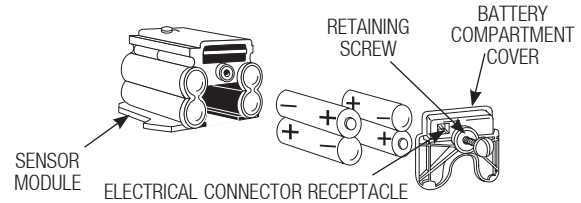

!!! IMPORTANT !!!

NEVER INSTALL MIXED BATTERY TYPES: (CARBON-ALKALINE-LITHIUM), PRIMARY AND SECONDARY CELLS (NON-RECHARGEABLE VS RECHARGEABLE) REPLACE ALL 4 BATTERIES AT THE SAME TIME WITH FRESH BATTERIES FAILURE ON THE ABOVE CAN REDUCE BATTERY LIFE, CAUSE BATTERY LEAKAGE, AND RESULT IN PRODUCT DAMAGE.

16 - TROUBLESHOOTING

1. Sensor Flashes Continuously Only When User Steps Within Range.

- A. Unit in Start-Up mode; no problem. This feature is active for the first ten (10) minutes of operation.

2. Valve Does Not Flush; Sensor Not Picking Up User.

- A. Range too short; increase the range.

3. Valve Does Not Flush; Sensor Picking Up Opposite Wall or Surface, or Only Flushes When Someone Walks By. Light Flashes Continuously for First 10 Minutes Even with No One in Front of the Sensor.

- A. Range too long; shorten range.

4. Valve Does Not Flush Even After Adjustment.

- A. Improper Range Adjustment; Follow Instructions and repeat steps.
B. Batteries completely used up; replace batteries.
C. Problem with Electronic Sensor Module; replace Electronic Sensor Module.

5. Light Blinks 4 Times When User Steps Within Range.

- A. Batteries low; replace batteries.

6. Valve Does Not Shut Off.

- A. Bypass orifice in diaphragm is clogged with dirt or debris, or bypass is clogged by an invisible gelatinous film due to "over-treated" water. Remove flex tube diaphragm and wash under running water.

Note: Size of Orifice in the Bypass is of utmost importance for the proper metering of water by the valve. DO NOT ENLARGE OR DAMAGE THIS ORIFICE. Replace flex tube diaphragm if cleaning does not correct the problem.

- B. Dirt or debris fouling stem or flex tube diaphragm. Remove flex tube diaphragm and wash under running water.
C. O-ring on stem of flex tube diaphragm is damaged or worn. Replace O-ring if necessary.
D. Problem with Electronic Sensor Module; replace Sensor Module. Try swapping out module with working unit to test module function.
E. Are there audible clicks from the solenoid?
No, possibly solenoid stuck in open position, replace solenoid
Yes, Check solenoid properly screwed into inside cover, check to make sure locking ring was secured properly.
F. If module is working and solenoid clicking, check diaphragm for perforations in diaphragm disc; replace

7. Not Enough Water to Fixture.

- A. Wrong Flush Volume Regulator installed in Flex Tube Diaphragm Kit. Install the correct Regulator (see Section 7 of these instructions).
B. Wrong G2/ECOS model installed; i.e., 1 gpf. urinal installed on closet fixture. Replace with proper G2/ECOS model, or refer to the G2/ECOS Conversion Guide to convert existing unit to the proper model.
C. Enlarged Bypass in Diaphragm. Replace Flex Tube Diaphragm.
D. Control Stop not adjusted properly. Readjust Control Stop.
E. Inadequate volume or pressure at supply. Increase water pressure or supply (flow) to valve. Consult factory for assistance.

8. Too Much Water to Fixture.

- A. Wrong flush volume regulator installed in flex tube diaphragm kit. Install the correct regulator (see Step 7 of these instructions).
B. Control Stop not adjusted properly. Readjust Control Stop.
C. Wrong G2/ECOS model installed; i.e., 3 gpf. model installed on 1.0 or 1.5 gal. urinal fixture. Replace with proper G2/ECOS model, or refer to the G2/ECOS

Conversion Guide to convert existing unit to the proper model.

- D. Dirt in diaphragm bypass. Clean under running water or replace flex tube diaphragm.

Note: The EBV-46-A Beam Deflector is no longer required or available for the G2/ECOS.

!!! IMPORTANT !!!

PROTECT THE CHROME OR SPECIAL FINISH OF SLOAN FLUSHMETERS — DO NOT USE TOOTHED TOOLS TO INSTALL OR SERVICE THESE VALVES. USE A SLOAN A-50 SUPER-WRENCH™, SLOAN A-109 PLIER WRENCH OR SMOOTH JAWED SPUD WRENCH TO SECURE ALL COUPLINGS. ALSO SEE "CARE AND CLEANING" SECTION

!!! IMPORTANT !!!

THIS PRODUCT CONTAINS MECHANICAL AND/OR ELECTRICAL COMPONENTS THAT ARE SUBJECT TO NORMAL WEAR. THESE COMPONENTS SHOULD BE CHECKED ON A REGULAR BASIS AND REPLACED AS NEEDED TO MAINTAIN THE VALVE'S PERFORMANCE.

!!! IMPORTANT !!!

LAWS AND REGULATIONS PROHIBIT THE USE OF HIGHER FLUSHING VOLUMES THAN LISTED ON FIXTURE OR FLUSHOMETER

!!! IMPORTANT !!!

THE CONTROL STOP SHOULD NEVER BE OPENED TO THE POINT WHERE THE FLOW FROM THE VALVE EXCEEDS THE FLOW CAPABILITY OF THE FIXTURE. IN THE EVENT OF A VALVE FAILURE, THE FIXTURE MUST BE ABLE TO ACCOMMODATE A CONTINUOUS FLOW FROM THE VALVE.

!!! IMPORTANT !!!

WITH THE EXCEPTION OF CONTROL STOP INLET, DO NOT USE PIPE SEALANT OR PLUMBING GREASE ON ANY VALVE COMPONENT OR COUPLING!

!!! IMPORTANT !!!

THE STRAP WRENCH PROVIDED WITH SLOAN ECOS® ELECTRONIC IS A CONVENIENCE TOOL AND IS NOT TO BE USED TO REMOVE OR INSTALL THE FLUSHOMETER COUPLINGS. USE STRAP WRENCH ONLY TO INSTALL SLOAN ECOS® ELECTRONIC LOCKING RING.

RECOMMENDED WALL PLATE LOCATIONS

- Centered over Flushometer

- On stall door

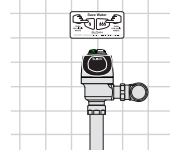

CARE AND CLEANING

DO NOT use abrasive or chemical cleaners to clean flushometers as they may dull the luster and attack the chrome or special decorative finishes. Use ONLY soap and water, then wipe dry with clean cloth or towel.

While cleaning the bathroom tile, the Flushometer should be protected from any splattering of cleaner. Acids and cleaning fluids can discolor or remove chrome plating.

PARTS LIST

Item # Part # Description

Items Included with RESS Retrofit and Complete Sloan ECOS Flush Valves

- 1 WES-55-A* Cover/Ring/Sensor Assembly - 1.6/1.1 Dual Flush WC
- WES-60-A* Cover/Ring/Sensor Assembly - 1.6/1.1w/†Zurn® ring Dual Flush WC
- WES-57-A* Cover/Ring/Sensor Assembly 1.28/1.1 - Dual Flush
- EBV-341-A* Cover/Ring/Sensor Assembly 0.5 & 0.25 Urinal
- EBV-381-A* Cover/Ring/Sensor Assembly 0.125 Urinal
- 2A EBV-191-A Cover Assembly - Dual Flush
- 2B EBV-142-A Cover Assembly - Single Flush
- 3A WES-23-A Button Cover Assembly with Screws - Dual Flush
- 3B EBV-130-A Single Button Repair Kit
- 4 EBV-131 Lens Window Cover
- 5 EBV-14 Locking Ring
- EBV-30 Locking Ring - for †Zurn® valves
- 6 EBV-196-A* Module - ECOS Electronic 1.6/1.1 gpf Dual Flush
- EBV-1054-A* Module - ECOS Electronic 1.28/1.1 gpf Dual Flush
- EBV-387-A* Module - ECOS Electronic 0.5 & 0.25 Urinal
- EBV-386-A* Module - ECOS Electronic 0.125 Urinal
- 7 EBV-134 Cover Rest Plate
- 8 EBV-145-A Inside Cover Assembly (includes solenoid)
- 9 EBV-136-A Solenoid
- 10 EBV-1020-A Flex Tube Diaphragm Assembly 1.6
- EBV-1024-A Flex Tube Diaphragm Assembly 1.28
- EBV-1023-A Flex Tube Diaphragm Assembly 0.5
- EBV-1025-A Flex Tube Diaphragm Assembly 0.25 & 0.125
- 11 Flush Volume Regulator (included in 10)
- 12 EBV-1017-A Handle Cap (RESS Retrofit Models only)
- 13 EBV-91 Range Adjustment Tool
- 14 EBV-22 Strap Wrench
- 15 EBV-137 7/64" Hex Wrench
- 16 WES-19 English Operation Instruction Plate
- WES-22 Spanish Operation Instruction Plate

Items Included with Complete Sloan ECOS Valves Only

- 17 H-633-AA † † Sweat Solder Kit
- 18 H-700-A † † Bak-Chek® Control Stop
- 19 H-1010-A Vandal Resistant Stop Cap
- 20 EBV-36-A Valve Body
- 21A V-600-AA 1½" (38 mm) x 10" (254 mm) Vacuum Breaker (Model 8110 & 8111)
- V-600-AA 1½" (38 mm) x 23" (584 mm) Vacuum Breaker (Model 8115)
- V-600-AA 1½" (38 mm) x 26" (660 mm) Vacuum Breaker (Model 8116)
- 21B V-600-AA ¾" (19 mm) Vacuum Breaker (Model 8186) (Urinal Models)
- 22A F-5-AT 1½" Spud Coupling Assembly (Water Closet Models)
- 22B F-5-AW ¾" Spud Coupling Assembly (Model 8186) (Urinal Models)

*-BT Sloan Connected Product Models Available

† † Contact Tech Support for Available Sizes

FCC INFORMATION TO USERS

This equipment has been tested and found to comply with the limits for a class B digital devices, pursuant to Part 15 of the FCC Rules. These limits are designed to provide reasonable protection against harmful interference in a residential installation. This equipment generates, uses, and can radiate radio frequency energy and, if not installed and used in accordance with the instruction manual, may cause harmful interference to radio or television reception, which can be determined by turning the equipment off and on, the user is encouraged to try to correct the interference by one or more of the following measures:

- Reorient or relocate the receiving antenna
- Increase the separation between the equipment and receiver
- Connect the equipment into an outlet on a circuit different from that to which the receiver is connected
- Consult the dealer or an experienced radio/TV technician for help

When further assistance is required,

please contact Sloan Technical Support at:

+1.888.SLOAN.14 (+1.888.756.2614) or visit us online at: sloan.com

SLOAN • 10500 Seymour Avenue • Franklin Park, IL 60131

Phone: +1.800.982.5839 • Fax: +1.800.447.8329 • sloan.com

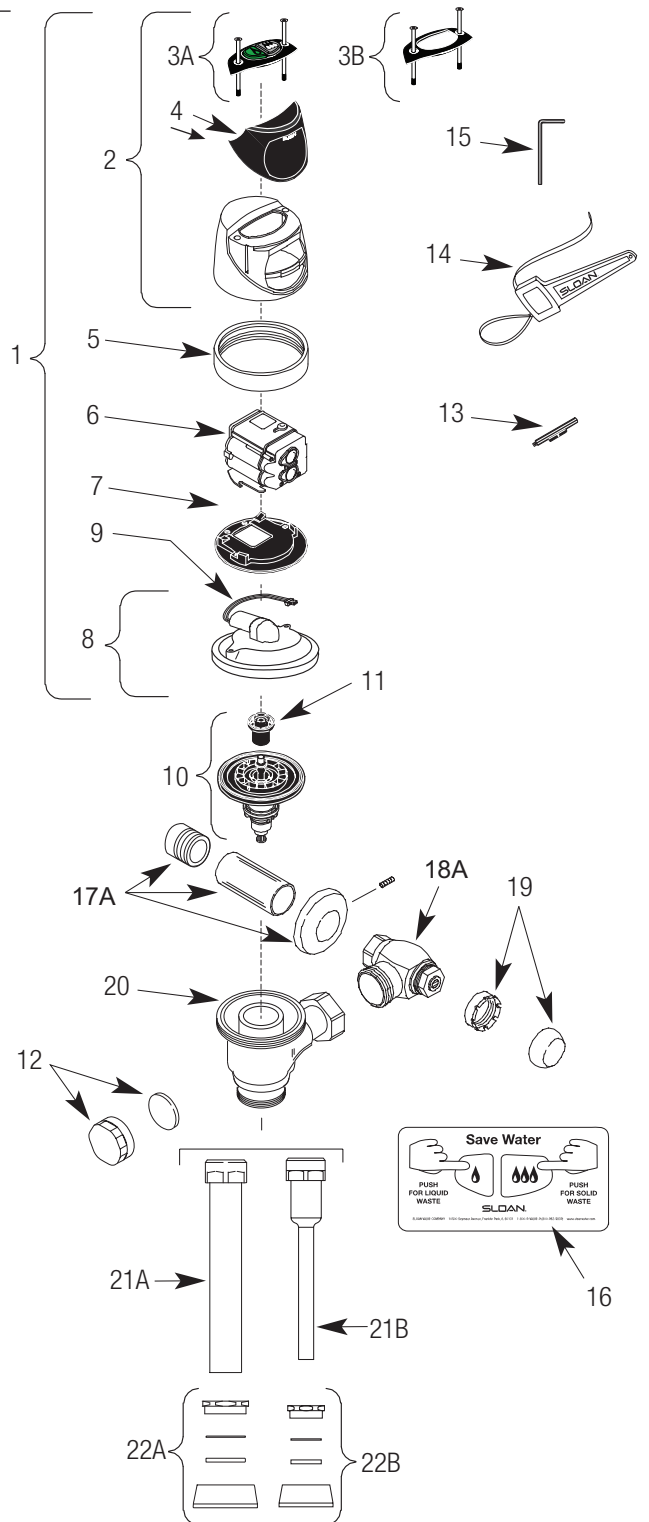

Manufactured in the U.S.A. by Sloan Valve Company under one or more of the following patents: U.S. Patents. 4,839,039; 5,195,720; 5,295,655; 5,542,718; 5,558,120; 5,564,460; 5,887,848; 5,967,182; 6,212,697; 6,382,586; 6,619,614; 6,685,158; 6,691,979; Des. 411,609.
Other Pats. Pending. BAK-CHEK®, CID®, COURTESY FLUSH®, PARA-FLO®, PERMEX®, TURBO-FLO®.

†The brands and/or products names referenced herein may be subject to trademark rights of their respective owners. Use of the brands and names is for identification purposes only and does not imply affiliation with or endorsement by Sloan.

The information contained in this document is subject to change without notice.