

INSTALLATION INSTRUCTIONS FOR OPTIMA® SYSTEM SENSOR ACTIVATED SLOAN® CONCEALED WITH TRUE MECHANICAL OVERRIDE FLUSHOMETERS

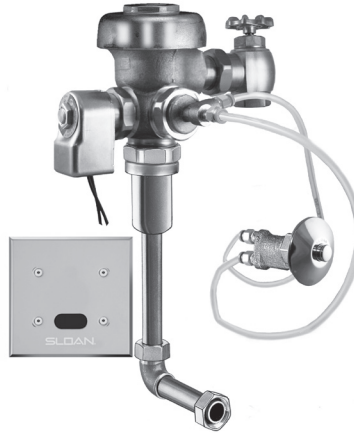

MODEL 152



MODEL 195

Concealed Closet Flushometers 1-1/2" Rear Spud

- Model 152 ES-S TMO

Concealed Urinal Flushometers 3/4" Rear Spud

- Model 195 ES-S TMO



LIMITED WARRANTY

Unless otherwise noted, Sloan Valve Company warrants this product, manufactured and sold for commercial or industrial uses, to be free from defects in material and workmanship for a period of three (3) years (one (1) year for special finishes, SF faucets, PWT electronics and 30 days for PWT software) from date of first purchase. During this period, Sloan Valve Company will, at its option, repair, replace, or refund the purchase price of any product which fails to conform with this warranty under normal use and service. This shall be the sole and exclusive remedy under this warranty. Products must be returned to Sloan Valve Company, at customer's cost. No claims will be allowed for labor, transportation or other costs. This warranty extends only to persons or organizations who purchase Sloan Valve Company's products directly from Sloan Valve Company for purpose of resale. This warranty does not cover the life of the batteries.

THERE ARE NO WARRANTIES WHICH EXTEND BEYOND THE DESCRIPTION ON THE FACE HEREOF. IN NO EVENT IS SLOAN VALVE COMPANY RESPONSIBLE FOR ANY CONSEQUENTIAL DAMAGES OF ANY MEASURE WHATSOEVER.

ROUGH-IN

MODEL 152

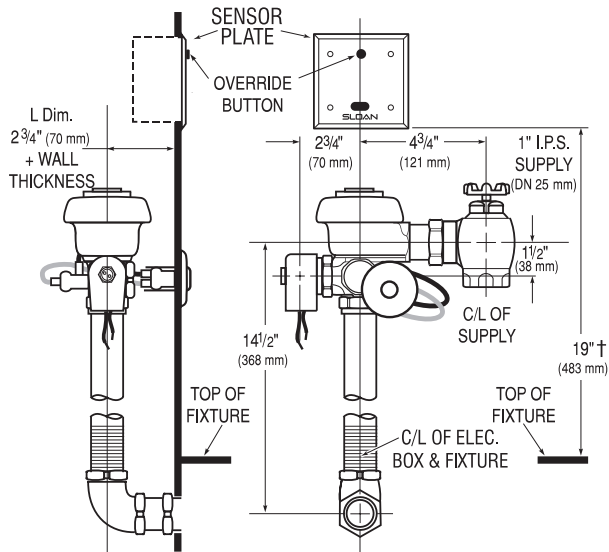

MODEL 195

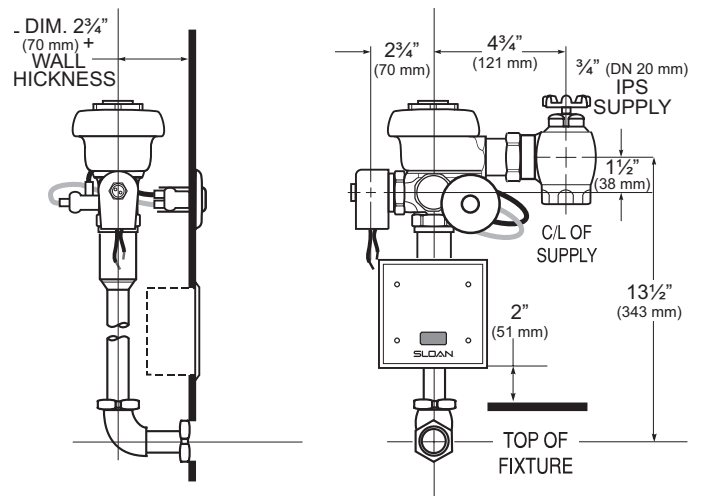

SENSOR LOCATION & POSITIONING IS CRITICAL!

Failure to properly position the electrical boxes to the plumbing rough-in will result in improper installation and impair product performance. All tradesmen (plumbers, electricians, tile setters, etc.) involved with the installation of this product must coordinate their work to assure proper product installation.

† POSITION OF SENSOR BOX CAN BE RAISED OR LOWERED 1" (25 mm) IF IN CONFLICT WITH HANDICAP GRAB BARS.

PRIOR TO INSTALLATION

Check the "L" dimension shown on the Flushometer package is correct for your application. Determine the "L" dimension for your application by using the following formula:

$$\text{"L" dimension} = \text{Wall Thickness (to nearest the whole inch)} + 2\text{-}3/4\text{" (69 mm)}$$

Prior to installation, install the items listed below:

- Electrical wiring to the transformer box (120 VAC, 2 amp service required for each EL-154, 24 VAC, 50 VA transformer used)
- Bore a 1-1/2" (38 mm) opening in wall for the hydraulic push button actuator
- Bore a 2" (51 mm) opening in wall for piping (if required)
- Closet/Urinal fixture
- Water supply line
- Drain line

IMPORTANT:

- **ALL PLUMBING AND ELECTRICAL WIRING SHOULD BE INSTALLED IN ACCORDANCE WITH APPLICABLE CODES AND REGULATIONS.**
- **WATER SUPPLY LINES MUST BE SIZED TO PROVIDE AN ADEQUATE VOLUME OF WATER FOR EACH FIXTURE.**
- **A 24 VAC STEP-DOWN TRANSFORMER MUST BE USED.**
- **WHEN INSTALLING A FLUSHOMETER, IT IS IMPORTANT THAT THE FLUSH MODEL MATCHES THE REQUIREMENTS OF THE PLUMBING FIXTURE.**
- **FLUSH ALL WATER LINES PRIOR TO MAKING CONNECTIONS.**

Sloan flushometers are designed to operate with 15 to 100 psi (104 to 689 kPa) of water pressure. **THE MINIMUM PRESSURE REQUIRED TO THE VALVE IS DETERMINED BY THE TYPE OF FIXTURE SELECTED.** Consult fixture manufacturer for minimum pressure requirements.

Most Low Consumption water closets (1.6 gallon/6.0 liter) require a minimum flowing pressure of 25 psi (172 kPa).

TRANSFORMER INSTALLATION

Install transformer (EL-154) on a 2-Gang electrical Box, 4" x 4" x 2-1/2" (102 mm x 102 mm x 64 mm) in a convenient location; refer to the illustration at right (Figure 1).

Note: One Sloan EL-154 transformer can operate up to ten OPTIMA equipped flushometers. Run 18-gauge wire from transformer to flushometer(s). Wire supplied by others. DO NOT supply power to transformer until installation of flushometer is complete.

Note: A maximum of ten (10) flushometer units can operate from one (1) Sloan EL-154 Transformer, Class 2, UL Listed, 50 VA (min.) at 24 VAC, plate mounted.

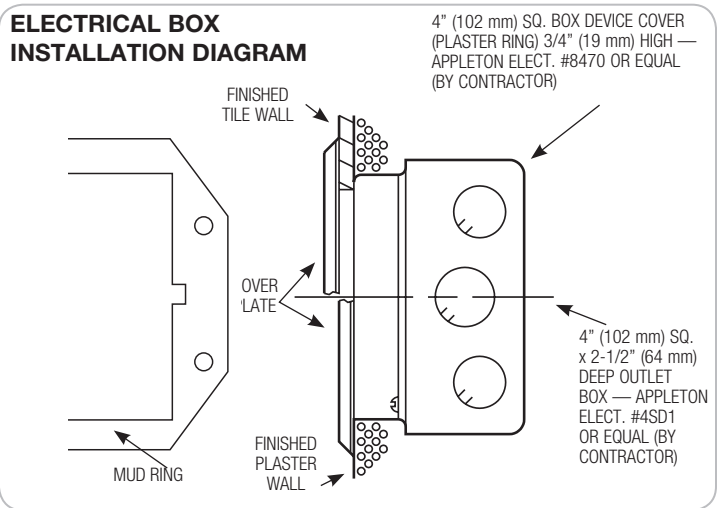

Figure 1

SENSOR/SOLENOID BOX LOCATIONS

Concealed Optima ES-S flushometer with True Mechanical Override models employ one (1) electrical box. Refer to rough-in illustrations for locations.

Note: Install plaster ring so screw holes are on left and right side of box.

Note: Break tiles to allow screw holes in plaster to show.

TOOLS REQUIRED FOR INSTALLATION

- Sloan A-50 "Super-Wrench™," Sloan A-109 Plier Wrench or smooth jawed spud wrench
- Wire stripper/crimping tool
- 5/64" hex wrench (supplied)

!!! IMPORTANT !!!

NEVER OPEN CONTROL STOP TO WHERE THE FLOW FROM THE VALVE EXCEEDS THE FLOW CAPABILITY OF THE FIXTURE. IN THE EVENT OF A VALVE FAILURE, THE FIXTURE MUST BE ABLE TO ACCOMMODATE A CONTINUOUS FLOW FROM THE VALVE.

!!! IMPORTANT !!!

PROTECT THE FINISH OF THE FLUSHOMETER – DO NOT USE TOOTHED TOOLS TO INSTALL OR SERVICE THESE VALVES. USE A SLOAN A-50 Super-Wrench™, Sloan A-109 Plier Wrench OR SMOOTH JAWED SPUD WRENCH TO SECURE ALL COUPLINGS. ALSO SEE "CARE AND CLEANING" SECTION.

!!! IMPORTANT !!!

EXCEPT FOR CONTROL STOP INLET, DO NOT USE PIPE SEALANT OR PLUMBING GREASE ON ANY VALVE COMPONENT OR COUPLING!

!!! IMPORTANT !!!

THIS PRODUCT CONTAINS MECHANICAL AND/OR ELECTRICAL COMPONENTS THAT ARE SUBJECT TO NORMAL WEAR. THESE COMPONENTS SHOULD BE CHECKED ON A REGULAR BASIS AND REPLACED AS NEEDED TO MAINTAIN THE VALVE'S PERFORMANCE.

If you have questions about how to install your flushometer, consult your local Sloan Representative or call Sloan Technical Support at:
1-888-SLOAN-14 (1-888-756-2614)

1 - INSTALL OPTIONAL SWEAT SOLDER ADAPTER (ONLY IF YOUR SUPPLY PIPE DOES NOT HAVE A MALE THREAD) AND CONTROL STOP

- A** To install the optional sweat solder adapter: Cut water supply line pipe 1-1/4" (32 mm) shorter. Slide threaded adapter fully onto pipe and sweat solder to pipe.
- B** Install the Sloan Bak-Chek® control stop to the water supply line with the outlet positioned as required.

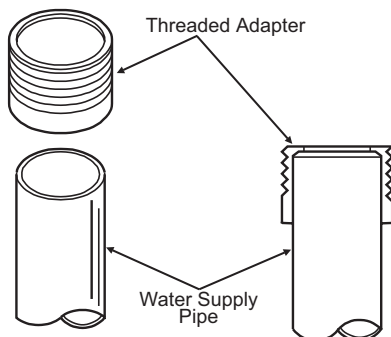

!!! IMPORTANT !!!
WITH THE EXCEPTION OF THE CONTROL STOP INLET, DO NOT USE PIPE SEALANT OR PLUMBING GREASE ON ANY VALVE COMPONENT OR COUPLING!

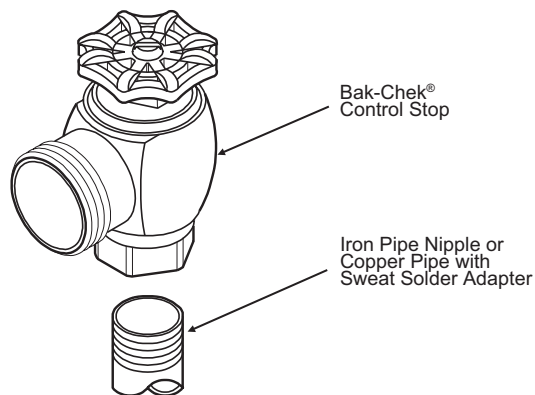

2 - INSTALL METAL PUSH BUTTON ACTUATOR

- A** Drill a 2" (51 mm) diameter hole through wall, if needed.
- B** Screw threaded rod into back of push button actuator.
- C** From behind wall, run plastic tubing through space sleeve (notched end of toward rear) and through wall. Spacer sleeve is only required if wall thickness is less than 2" (51 mm).
- D** Remove tube fitting nuts from push button actuator fittings and slide one nut onto each plastic tube. Slide each plastic tube onto its corresponding push button actuator fitting and tighten tube fitting nuts.

!!! IMPORTANT !!!
MUST USE SLOAN APPROVED TUBING ONLY

NOTE
 Observe the "L" and "O" markings on push button actuator. Mark each tube so that it can be identified and connected to corresponding fittings marked "L" and "O" on valve actuator housing.

- E** Insert push button actuator assembly into the 2" (51 mm) diameter hole in wall.

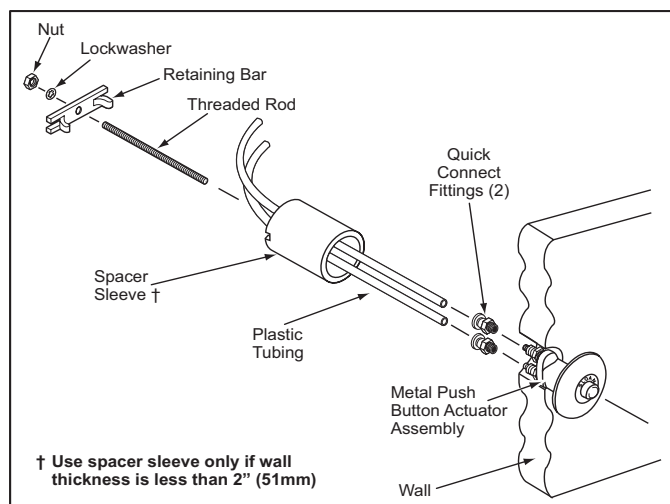

- F** From behind wall, slide spacer sleeve (if required) over threaded rod and rest it against rear of wall. Slide retaining bar onto threaded rod and into slots of sleeve. Install lockwasher and nut onto threaded rod and tighten securely. Carefully cut excess threaded rod making certain not to damage the plastic tubing.

3 - INSTALL VACUUM BREAKER FLUSH CONNECTION AND BUTTON

- A** Assemble pipe, elbows, couplings, nylon slip gaskets, rubber gaskets, and flanges, as illustrated.
- B** Insert tube into fixture spud.
- C** Hand tighten all couplings.

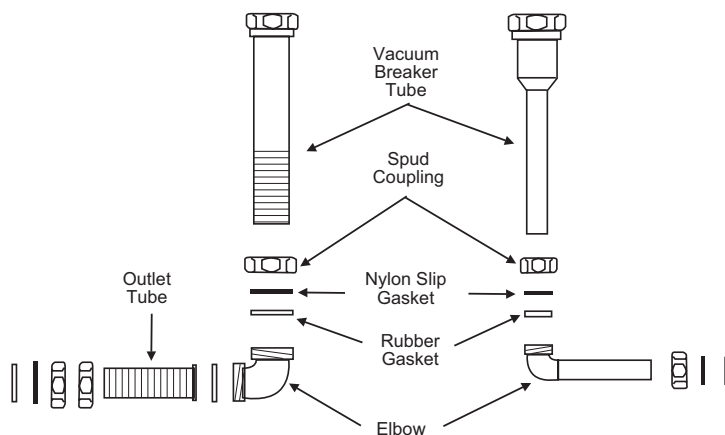

4 - INSTALL FLUSHOMETER

NOTE

For high efficiency urinal flushometers (0.5, 0.25 and 0.125 gpf), it is necessary to first insert the flow control component into the tailpiece assembly. See the H1015A flow control kit and separate instructions for details on how to install.

- A** Lubricate tailpiece o-ring with water. Insert adjustable tailpiece into control stop. Tighten tailpiece coupling by hand.
- B** Align flushometer directly above the vacuum breaker flush connection by sliding the flushometer Body IN or OUT as needed. Tighten vacuum breaker coupling by hand.
- C** Align flushometer body and securely tighten first the tailpiece coupling (1), then the vacuum breaker and pipe couplings (2), and finally the spud coupling. Use a wrench to tighten these couplings in the order shown.

NOTE

Max. adjustment of Sloan Adjustable Tailpiece is $\frac{1}{2}$ " (13 mm) IN or OUT from the standard $4\frac{3}{4}$ " (121 mm) (C of Valve to C of Control Stop).
If roughing-in measurement exceeds $5\frac{1}{4}$ " (133 mm), consult factory for longer tailpiece.

IMPORTANT!!!

USE A Sloan A-50 "Super-Wrench™" OR SMOOTH JAWED SPUD WRENCH TO SECURE ALL COUPLINGS. THIS WILL ELIMINATE DAMAGE TO FINISH THAT NORMALLY OCCURS WHEN SLIP-JOINT PLIERS, PIPE WRENCHES OR OTHER "TOOTHED" TOOLS ARE USED.

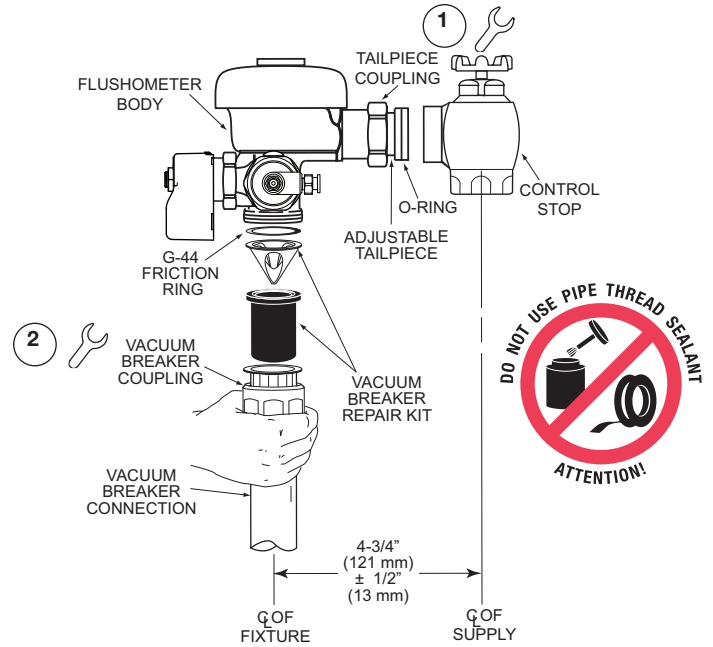

5 - INSTALL VALVE ACTUATOR

- A** Cut off excess plastic tubing so that there will be about 3 to 4 inches (72 to 102 mm) of slack when actuator is installed. If the "L" and "O" markings on the tubing will be cut off, remark tubing appropriately so as not to lose identification.
- B** Remove tube fitting nuts from valve actuator and slide one nut onto each plastic tube.
- C** Slide plastic tubing onto its corresponding valve actuator fitting and tighten tube fitting Nuts.

NOTE

Observe the "L" and "O" markings on push button actuator. Mark each tube so that it can be identified and connected to corresponding fittings marked "L" and "O" on valve actuator housing.

- D** Install valve handle cap and adapter assembly (EL-190-A) on valve opening not used by hydraulic actuator assembly (typically in back of valve body).

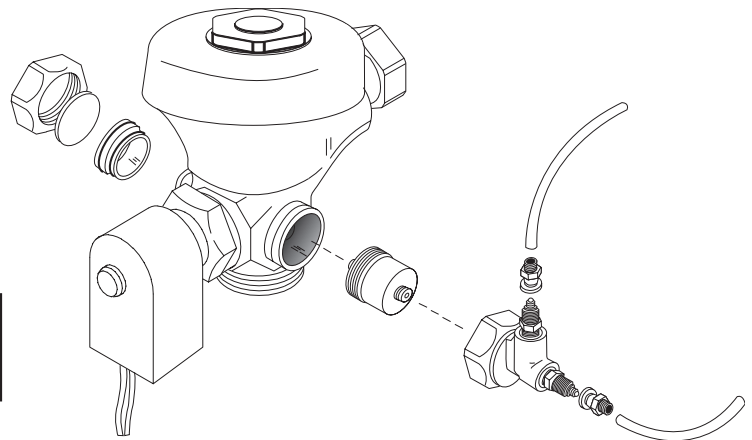

6 - INSTALL SENSOR BOX MOUNTING PLATE

- A** Install sensor mounting plate using the screws provided.

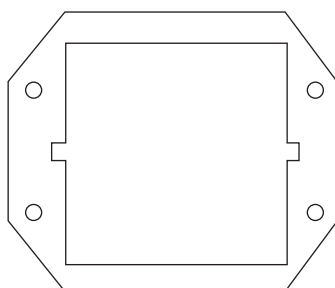

Preferred Mud Ring Orientation

SENSOR BOX MOUNTING PLATE

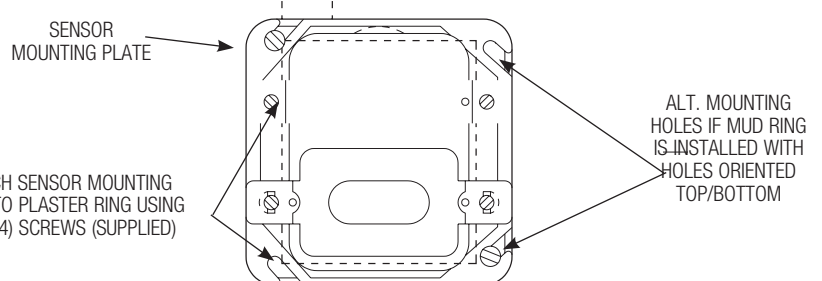

7 - ELECTRICAL HOOK-UP

- A** Be certain power is OFF to prevent damage to electrical components. Connect sensor to transformer and solenoid coil EXACTLY as shown.
- B** Connect 24 volt source lead to terminal labeled "24 VAC IN" of sensor.
- C** Connect solenoid lead to terminal labeled "TO VALVE" of sensor.
- D** Connect remaining solenoid lead to remaining 24 volt source lead.
- E** Connect transformer and sensor wire leads to coil wire leads.
- F** Secure solenoid operator to Flushometer by tightening the solenoid coupling. Tighten housing retention nut.

Wiring Diagram

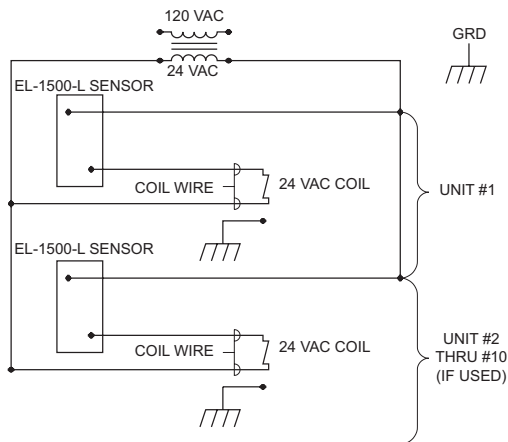

Wiring Diagram for One Flush Valve

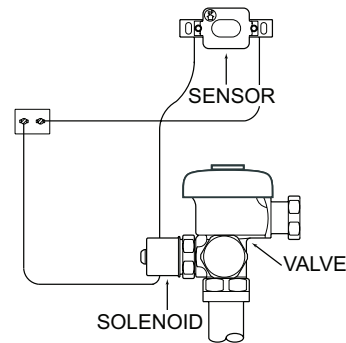

Wiring Diagram for Multiple Flush Valves

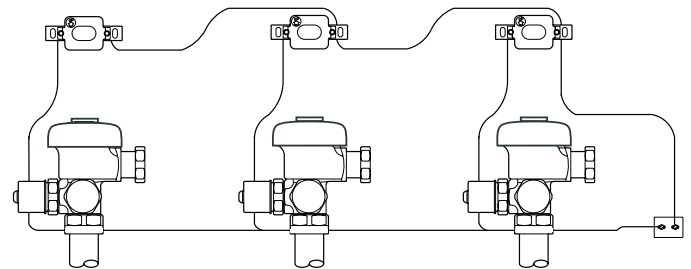

Note: Valve is not shown to complete assembly with control stop on.

8 - INSTALL SENSOR, YOKE AND COVER PLATE

- A** Install sensor (EL-1500 or EL-1500-L) into the 2-gang electrical box using two (2) long screws provided. Ensure that sensor lens faces outward and horizontally from finished wall.
- B** Mount assembled yoke to electrical box.
- C** Install sensor cover plate and secure with tamper-proof screws (EL-152).

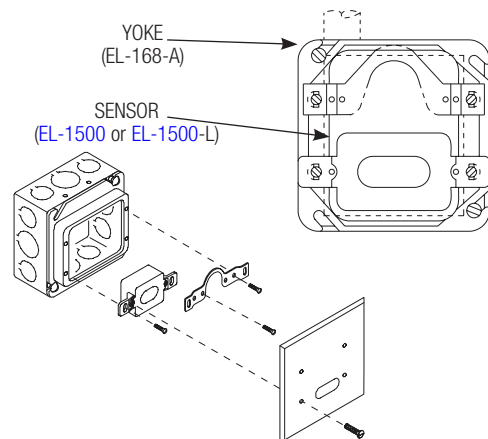

9 - FLUSH OUT SUPPLY LINE

- A** Make sure control stop is CLOSED.
- B** Remove flushometer cover.
- C** Remove flushometer cover and lift out Inside parts assembly. Install flushometer cover wrench tight.
- D** Open control stop. Turn on water supply to flush line of any debris or sediment.
- E** Shut off control stop, remove cover and reinstall Inside Parts Assembly. Install flushometer cover wrench tight. Do Not open control stop until Step 13.

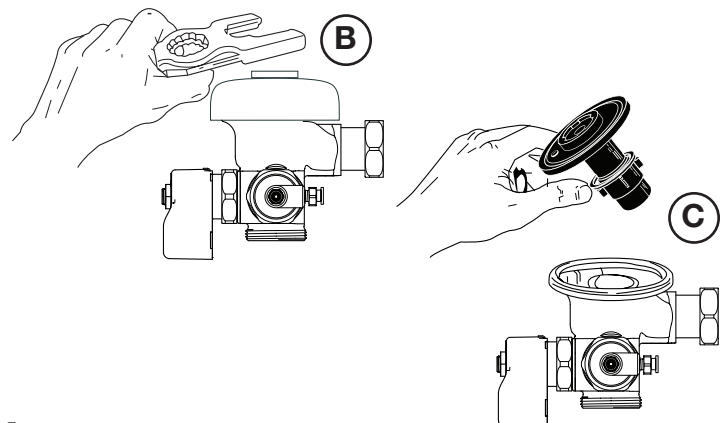
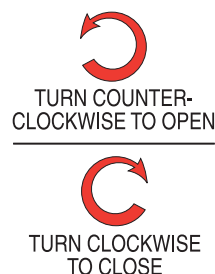

10 - POWER AND START-UP MODE

NOTE: IT IS RECOMMENDED THAT ALL ELECTRONIC CONNECTIONS BE TESTED WITH THE WATER SUPPLY OFF.

- A** Turn power ON. The self adaptive sensor automatically adapts to the surrounding environment when 24 volt supply is activated. No manual adjustments are required.
- B** Start-up mode will take approximately one (1) minute to complete its cycle and is important that no non-permanent target is present at this time. A continuous red light visible in sensor window indicates sensor is in the start-up mode. If the red light is flashing, this indicates that the sensor is picking up a target. Unless this target is a permanent fixture in the sensor's environment (i.e., a wall or stall door), it must be removed from the view of the sensor. If this target is permanent, the sensor will adapt itself around this target. In this case, disconnect the 24 volt power supply for twenty (20) seconds or more. Reconnect the 24 volt power supply at the transformer or fuse box. When the start-up cycle is complete there will be no light visible in the sensor window.

NOTE: IF 24 VOLT POWER SUPPLY IS EVER INTERRUPTED FOR LONGER THAN TWENTY (20) SECONDS, THE START-UP MODE AUTOMATICALLY BEGINS WHEN POWER IS RESTORED.

- C** Incorrect wiring or a short in the 24 volt power supply is indicated by a continuous warning signal seen in the sensor window. The visible red light flashes an "SOS" signal: three (3) short flashes, three (3) long flashes, three (3) short flashes and continually repeats this signal.

11 - DETECTION/ACTIVATION

- A** When an object is detected, a slowly flashing red light will appear in the sensor window. After approximately eight (8) to sixteen (16) seconds (closet) / eight (8) seconds (urinal), the light will flash rapidly indicating sensor is armed and ready to activate solenoid when the object leaves the detection area. The solenoid will be activated within 0.5 seconds (for urinals) or three (3) seconds (for water closets) after non-detection.

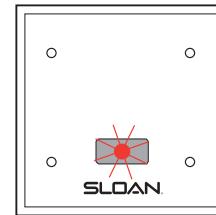

13 - TURN WATER ON AND ADJUST CONTROL STOP

- A** Adjust control stop to meet the flow rate required for proper cleansing of the fixture. Open control stop COUNTERCLOCKWISE one (1) FULL turn from the closed position.

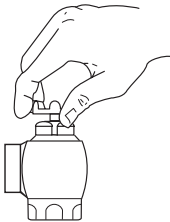

- C** Adjust control stop after each flush until the rate of flow delivered properly cleanses the fixture.

!!! IMPORTANT !!!

All Sloan Flushometers are engineered for quiet operation. Excessive water flow creates noise, while too little water flow may not satisfy the needs of the fixture. Proper adjustment is made when plumbing fixture is cleansed after each flush without splashing water out from the lip AND a quiet flushing cycle is achieved.

Never open Control Stop to where the flow from the valve exceeds the flow capability of the fixture. In the event of a valve failure, the fixture must be able to accommodate a continuous flow from the valve.

- B** Activate flushometer by placing hand in front of sensor lens for ten (10) seconds and then moving it away.

OPERATION

1. A continuous, invisible light beam is emitted from the sensor.

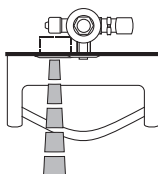
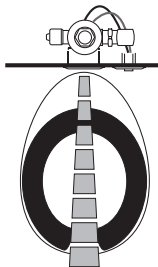

2. When a user enters the beam's effective range, for water closets 22" - 42" (559 mm - 1067 mm) and for urinals 15" - 30" (381 mm - 762 mm), the beam is reflected into the sensors scanning window and transformed into a low voltage electrical signal that activates a sixteen (16) second (closet) / eight (8) second (urinal) time delay circuit. The time delay circuit eliminates false operation from passers-by in the rest room. Once the time delay is completed, the output circuit is alerted and continues in a "hold" mode for as long as the user remains within the effective range of the sensor.

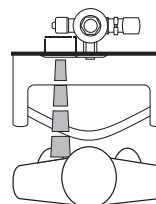
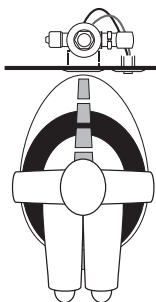

3. When the user steps away from the sensor, the loss of reflected light initiates an electrical "one-time" signal that energizes the solenoid operator, and activates the flushometer to flush the fixture. This occurs on the water closet approximately three (3) seconds after indication. This delay is built into the sensor to help prevent false flushing due to movement by the user. The circuit for both water closets and urinals then automatically resets and is ready for the next user.

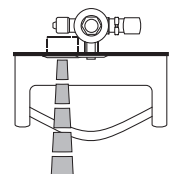
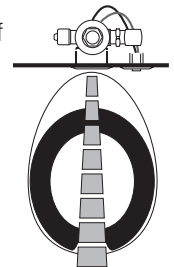

TROUBLESHOOTING GUIDE

NOTE: URINALS – When the sensor detects a user, a slow flashing red light appears in the sensor window. After eight (8) to ten (10) seconds, the light flashes rapidly to indicate that the sensor is armed. When the sensor no longer detects a user, the sensor immediately activates the solenoid valve after a 0.5 second delay.

WATER CLOSETS – Detection and activation are the same as for the urinal except when the sensor no longer detects an user, the sensor activates the solenoid valve after a three (3) second delay.

1. Valve does not function (red light does not flash when user steps in front of sensor).

- A. No power is being supplied to sensor. Ensure that the main power is turned "ON." Check transformer, leads and connections. Repair or replace as necessary.
- B. EL-1500 sensor is not operating. Replace the EL-1500 sensor.

2. Valve does not function (red light flashes when user steps in front of sensor).

- A. Red light stops flashing when user steps away and valve makes a "clicking" sound but does not flush.
 - a. No water is being supplied to the valve. Make certain that the water supply is turned "ON" and the Control Stop is open. No power is being supplied to sensor. Ensure that the main power is turned "ON." Check transformer, leads and connections. Repair or replace as necessary.
 - b. EL-128-A cartridge is fouled or jammed. Turn electronic power to valve "OFF" (failure to do so could result in damage to the solenoid coil. Remove the solenoid operator from the valve and remove the EL-128-A cartridge. Clean and/or repair as necessary.
- B. The red light stops flashing when user steps away but the valve does NOT make a "clicking" sound and does NOT flush.
 - a. EL-163-A solenoid shaft assembly is fouled or jammed. Turn electronic power to valve "OFF" (failure to do so could result in damage to the solenoid coil). Remove EL-101 or EL-166 nut from the solenoid operator. Remove the coil from the solenoid operator. Use a spanner wrench or pliers to remove the EL-163-A solenoid shaft assembly from valve. Clean and/or replace as necessary. Be sure to replace plunger spring when reassembling solenoid shaft assembly.
- C. The red light flashes three (3) short flashes, three (3) long flashes then three (3) short flashes ("S-O-S") and continues to repeat this cycle even when user steps out of the sensor's detection range.
 - a. EL-1500 sensor wiring connections are incorrect. Re-wire sensor to valve. One solenoid lead connects to the "TO VALVE" connection on sensor. One transformer lead connects to the "24 VAC IN" connection on sensor. Second solenoid lead and second transformer lead connect together.
 - b. Wiring to sensor is ground shorted. Find short in wiring circuit and correct.
 - c. EL-165-2 solenoid coil is burnt out or coil is not connected to solenoid plunger shaft. Reinstall or replace coil as necessary.

3. Volume of water is insufficient to adequately siphon fixture.

- A. Control stop is not open wide enough. Adjust control stop for desired water delivery.
- B. Low consumption unit is installed on water saver or conventional fixture. Replace diaphragm component parts of valve with kit that corresponds to appropriate flush volume of fixture.
- C. Inadequate water volume or pressure available from supply. Increase pressure or supply (flow rate) to the valve. Consult factory for assistance.

4. Length of flush is too long (long flushing) or valve fails to shut off.

- A. Water saver valve is installed on low consumption fixture. Replace diaphragm component parts of valve with kit that corresponds to appropriate flush volume of fixture.
- B. Relief valve in diaphragm is not seated properly or bypass hole in diaphragm is clogged. Disassemble inside diaphragm component parts and wash parts thoroughly. Replace worn parts if necessary.

5. Water splashes from fixture.

- A. Supply flow rate is more than necessary. Adjust control stop to meet flow rate required for proper cleansing of the fixture.

6. Leakage occurring at the push button.

- A. Damaged or worn seals or lime build up in the actuator cartridge. Replace with new HY-32-A cartridge.

7. The flushometer does not flush or flushes only once and will not flush a second time when the button is pushed.

- A. The plunger is lodged in the actuator cartridge or the plunger by-pass hole is clogged. Remove the actuator housing and cartridge from the flushometer. Clean under running water. If cartridge parts are worn, deteriorated or limed up and problem persists after cleaning, replace with new HY-83-A cartridge.
 - a. Turn off water at the control stop.
 - b. Unscrew the housing coupling nut from the flushometer.
 - c. Remove the actuator housing from the flushometer. The tubing connections can be left intact.
 - d. Remove the actuator cartridge from the flushometer body. Care should be taken so that upon removal the actuator does not abruptly separate due to spring compression within. If the actuator cartridge is lodged in the body cavity, grip the exposed portion gently with a pair of channel-lock pliers and rotate back and forth to loosen the o-ring seal.
 - e. Separate the actuator housing to reveal the spring and plunger.
- B. Plastic tubing installed incorrectly. Install Plastic tubing correctly.

8. The flushometer does not flush and a small amount of leakage is visible below the valve.

- A. Foreign material lodged in the cartridge. Remove the cartridge and inspect for foreign material. Clean under running water.
- B. Damaged or worn seals or lime build up in the actuator cartridge. Replace with new HY-32-A cartridge.
 - a. Remove the button or actuator assembly from the wall or fixture.
 - b. Disassemble the flange or button assembly from the actuator body.
 - c. Unscrew the cartridge from the actuator body. **NOTE: The metal push button was designed to be vandal-proof and thus requires removal from the wall for servicing.**
- C. Plastic tubing installed incorrectly. Install Plastic Tubing Correctly.

**When further assistance is required,
please contact Sloan Technical Support at:
1-888-SLOAN-14 (1-888-756-2614)**

!!! IMPORTANT !!!
**LAWS AND REGULATIONS PROHIBIT THE USE OF
HIGHER FLUSHING VOLUMES THAN LISTED ON
FIXTURE OR FLUSHOMETER.**

PARTS LIST

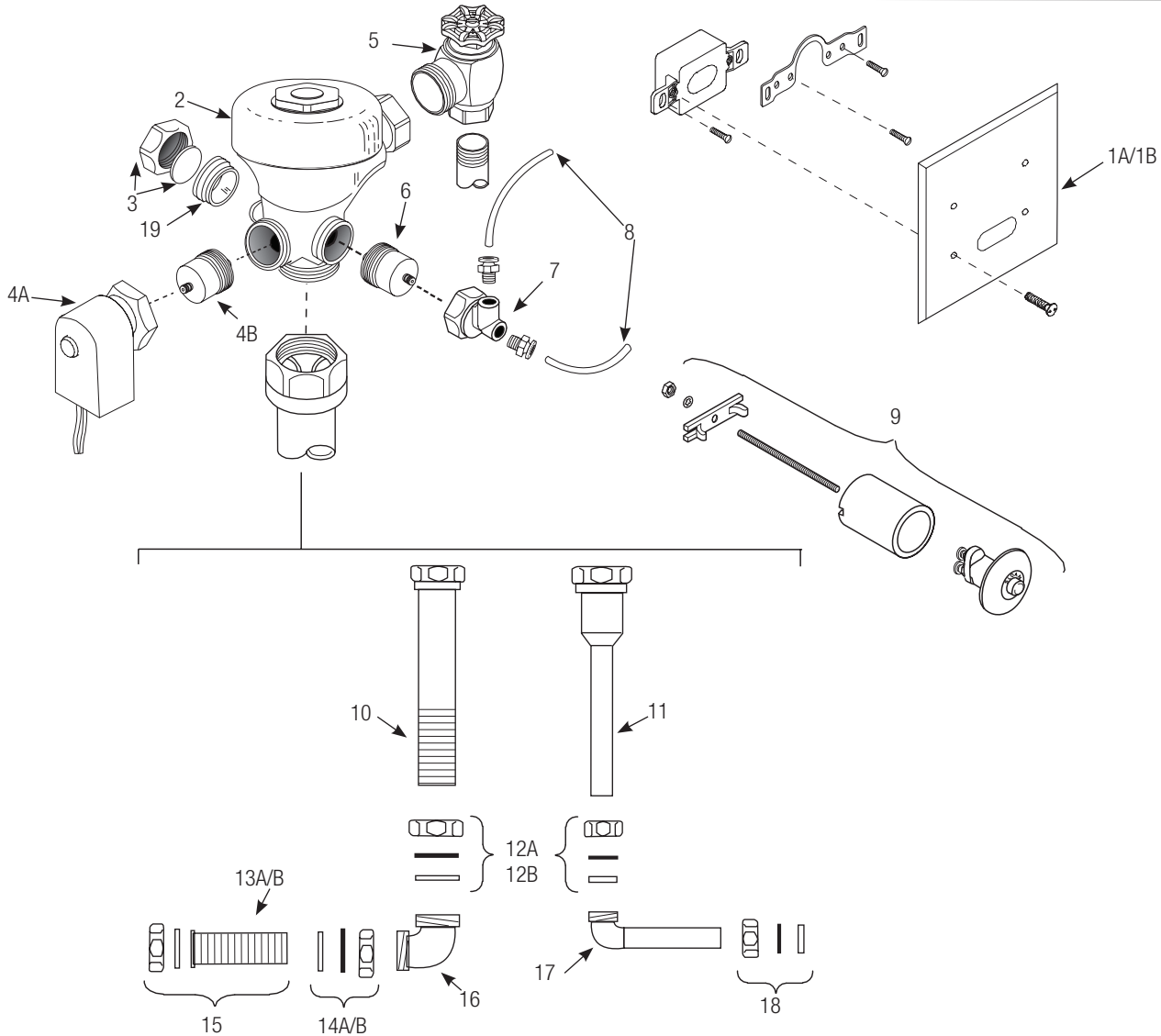

Item No.	Part No.	Description
1A	EL-1011-A	CP Cover Plate with Sensor (Mounting Screws included) (Model 152)
1B	EL-1007-A	CP Cover Plate with Sensor (Mounting Screws included) (Model 195)
2	‡	Valve Assembly
3	A-1013-A	Concealed Valve Handle Cap RB
4A	EL-138-2	RB Concealed 24V Solenoid Assembly
4B	EL-128-A	Cartridge Assembly
5	H-730-A	RB Bak-Chek® Control Stop
6	HY-83-A	Actuator Cartridge
7	HY-109-A-1	Valve Actuator Assembly
8	HY-30	¼" (6 mm) x 48" (1219 mm) Connecting Tubes
9	HY-100-A	Metal Push Button Assembly
10	V-500-AA	1½" (38 mm) Vacuum Breaker Assembly RB (Model 152)
11	V-500-AA	¾" (19 mm) Vacuum Breaker Assembly RB (Model 192)

Item No.	Part No.	Description
12A	F-2-AT	1½" (38 mm) Slip Joint Coupling Assembly RB (Model 152)
12B	F-2-AW	¾" (19 mm) Slip Joint Coupling Assembly RB (Model 192)
13A	F-110	1¼" (32 mm) Outlet Tube with Flange and Scoring (Model 152)
13B	F-100	1½" (38 mm) Outlet Tube with Flange and Scoring (Model 152)
14A	F-2-AU	1¼" (32 mm) Slip Joint Coupling Assembly RB (Model 152)
14B	F-2-AT	1½" (38 mm) Slip Joint Coupling Assembly RB (Model 152)
15	F-2-A	1½" (38 mm) Coupling with S-21 Gasket (Model 152)
16	F-21	1½" (38 mm) Double Male Slip Joint Elbow
17	F-15-A	ELL with ¾" (19 mm) Tail
18	F-2-AW	¾" (19 mm) Slip Joint Coupling
19	EL-190-A	Adapter Assembly

‡ Part number varies with valve model variation; consult factory.
The information contained in this document is subject to change without notice.

SLOAN • 10500 SEYMOUR AVENUE • FRANKLIN PARK, IL 60131

Phone: +1.800.982.5839 or +1.847.671-4300 • Fax: +1.800-447.8329 or +1.847.671.4380 • www.sloan.com