

## INSTALLATION INSTRUCTIONS FOR EXPOSED REGAL® XL WATER CLOSET AND URINAL FLUSHOMETERS

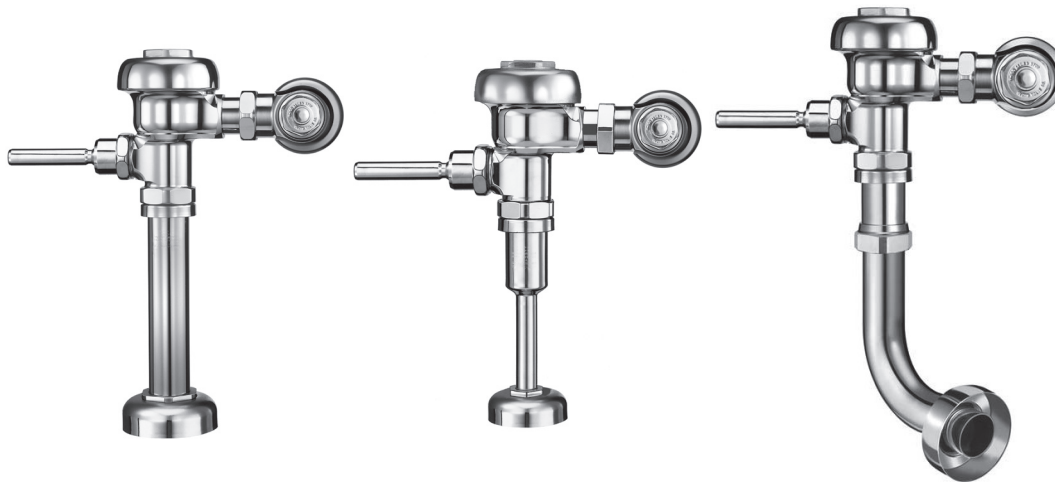

- Closet Flushometer**  
**1½" (38 mm) Top Spud**  
MODELS 110/111,  
113, 115 & 116
- Closet Flushometer**  
**1½" (38 mm) Back Spud**  
MODEL 120 & 122
- Service Sink Flushometer**  
**1½" (38 mm) Top Spud**  
MODEL 117
- Urinal Flushometer**  
**1¼" (32 mm) Top Spud**  
MODEL 180
- Urinal Flushometer**  
**¾" (19 mm) Top Spud**  
MODEL 186
- Squat Toilet Flushometer**  
**1½" (38 mm) Back Spud**  
MODEL 137

### LIMITED WARRANTY

Unless otherwise noted, Sloan Valve Company warrants this product, manufactured and sold for commercial or industrial uses, to be free from defects in material and workmanship for a period of three (3) years (one (1) year for special finishes, SF faucets, PWT electronics and 30 days for PWT software) from date of first purchase. During this period, Sloan Valve Company will, at its option, repair, replace, or refund the purchase price of any product which fails to conform with this warranty under normal use and service. This shall be the sole and exclusive remedy under this warranty. Products must be returned to Sloan Valve Company, at customer's cost. No claims will be allowed for labor, transportation or other costs. This warranty extends only to persons or organizations who purchase Sloan Valve Company's products directly from Sloan Valve Company for purpose of resale. This warranty does not cover the life of the batteries.

**THERE ARE NO WARRANTIES WHICH EXTEND BEYOND THE DESCRIPTION ON THE FACE HEREOF. IN NO EVENT IS SLOAN VALVE COMPANY RESPONSIBLE FOR ANY CONSEQUENTIAL DAMAGES OF ANY MEASURE WHATSOEVER.**

### PRIOR TO INSTALLATION

Before you install the Regal XL flushometer, be sure the items listed below are installed. Also, refer to the rough-in diagrams on the next page.

- Closet or urinal fixture
- Drain line
- Water supply line

#### IMPORTANT:

- **INSTALL ALL PLUMBING IN ACCORDANCE WITH APPLICABLE CODES AND REGULATIONS.**
- **WATER SUPPLY LINES MUST BE SIZED TO PROVIDE AN ADEQUATE VOLUME OF WATER FOR EACH FIXTURE.**
- **FLUSH ALL WATER LINES PRIOR TO MAKING CONNECTIONS.**

Sloan's flushometers are designed to operate with 10 to 100 psi (69 to 689 kPa) of water pressure. **THE MINIMUM PRESSURE REQUIRED TO THE VALVE IS DETERMINED BY THE TYPE OF FIXTURE SELECTED.** Consult fixture manufacturer for minimum pressure requirements. Most Low Consumption water closets (1.6 gpf/6.0 Lpf) require a minimum flowing pressure of 25 psi (172 kPa).

### TOOLS REQUIRED FOR INSTALLATION

- Straight blade screwdriver
- Sloan A-50 Super-Wrench™, Sloan A-109 Plier Wrench or smooth jawed spud wrench

# VALVE ROUGH-INS

## MODELS 110/111

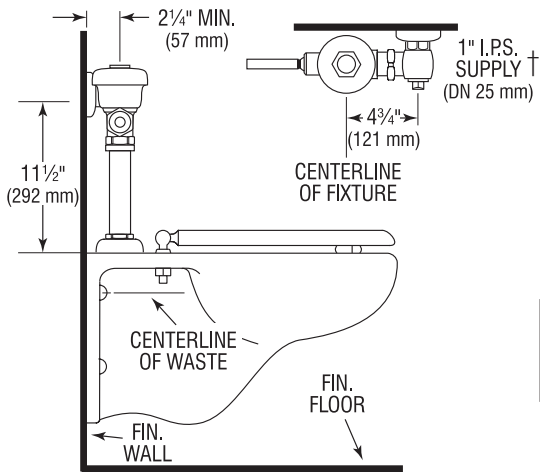

## MODELS 113, 115 & 116

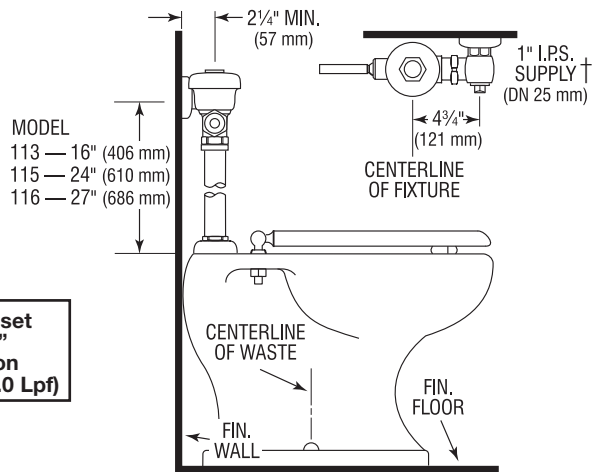

MODEL  
113 — 16" (406 mm)  
115 — 24" (610 mm)  
116 — 27" (686 mm)

**NOTE: Water Closet Valves with "-2.4" Model Designation deliver 2.4 gpf (9.0 Lpf)**

## MODEL 117

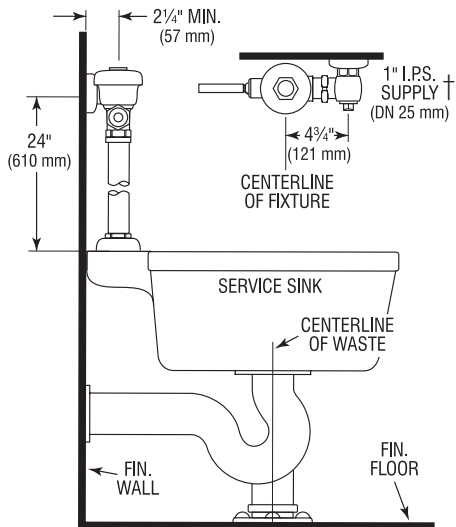

## MODELS 120/122

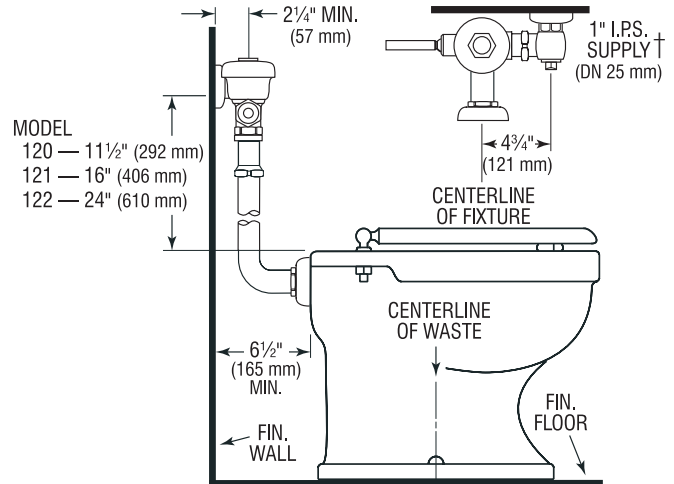

MODEL  
120 — 11 1/2" (292 mm)  
121 — 16" (406 mm)  
122 — 24" (610 mm)

## MODEL 180

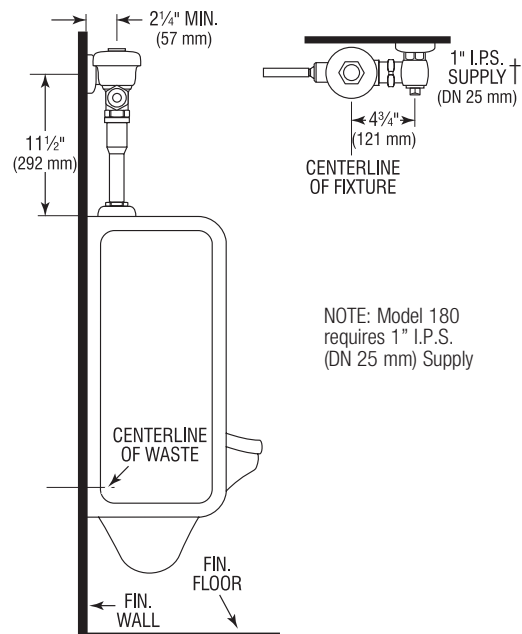

NOTE: Model 180 requires 1" I.P.S. (DN 25 mm) Supply

## MODEL 186

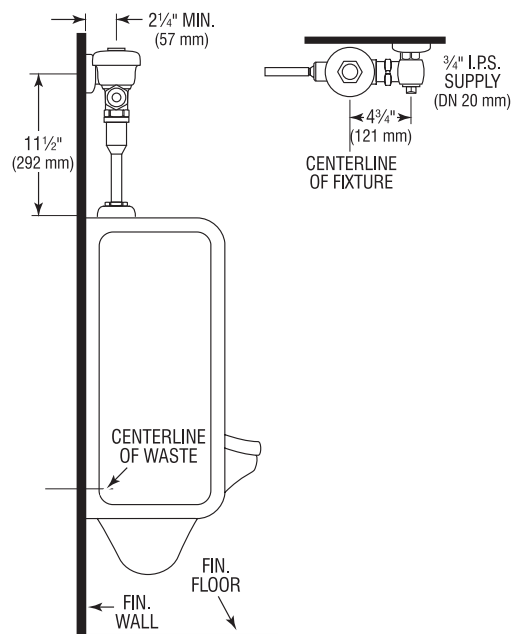

† 1" Control Stop is available with Whitworth Thread

### IMPORTANT NOTES:

- When mounted on an ADA accessible bowl, the rough-in to the supply inlet should be no higher than 37 1/2" or the handle will exceed maximum height allowances under ADA guidelines.
- New ADAAG Guidelines allow for Split or Offset Grab Bars, check with local authorities or reference section 604.5.2 of ADAAG.

**!!! IMPORTANT !!!**  
**WITH THE EXCEPTION OF CONTROL STOP INLET, DO NOT USE PIPE SEALANT OR PLUMBING GREASE ON ANY VALVE COMPONENT OR COUPLING!**

**!!! IMPORTANT !!!**  
**PROTECT THE FINISH OF SLOAN'S FLUSHOMETERS — DO NOT USE TOOTHED TOOLS TO INSTALL OR SERVICE THESE VALVES. USE A SLOAN A-50 Super-Wrench™, Sloan A-109 PLIER WRENCH OR SMOOTH JAWED SPUD WRENCH TO SECURE ALL COUPLINGS. SEE "CARE AND CLEANING" SECTION.**

**!!! IMPORTANT !!!**  
**THIS PRODUCT CONTAINS MECHANICAL AND/OR ELECTRICAL COMPONENTS THAT ARE SUBJECT TO NORMAL WEAR. THESE COMPONENTS SHOULD BE CHECKED ON A REGULAR BASIS AND REPLACED AS NEEDED TO MAINTAIN THE VALVE'S PERFORMANCE.**

**!!! IMPORTANT !!!**  
**NEVER OPEN CONTROL STOP TO WHERE THE FLOW FROM THE VALVE EXCEEDS THE FLOW CAPABILITY OF THE FIXTURE. IN THE EVENT OF A VALVE FAILURE, THE FIXTURE MUST BE ABLE TO ACCOMMODATE A CONTINUOUS FLOW FROM THE VALVE.**

**!!! IMPORTANT !!!**  
**LAWS AND REGULATIONS PROHIBIT THE USE OF HIGHER FLUSHING VOLUMES THAN LISTED ON FIXTURE OR FLUSHOMETER.**

Please take the time to read this manual to ensure proper product installation and longevity. Also, please visit our website to download our most recent documentation for this product.

If you have questions about how to install your Flushometer, consult your local Sloan Representative or call Sloan Technical Support at:

**1-888-SLOAN-14 (1-888-756-2614)**

## 1 - INSTALL SWEAT SOLDER ADAPTER (ONLY IF YOUR SUPPLY PIPE DOES NOT HAVE A MALE THREAD)

- A** Measure from finished wall to C/L of Fixture Spud. Cut pipe 1/4" (32 mm) shorter than this measurement. Chamfer O.D. and I.D. of water supply pipe.
- B** Slide Threaded Adapter fully onto pipe.
- C** Sweat solder the Adapter to pipe.

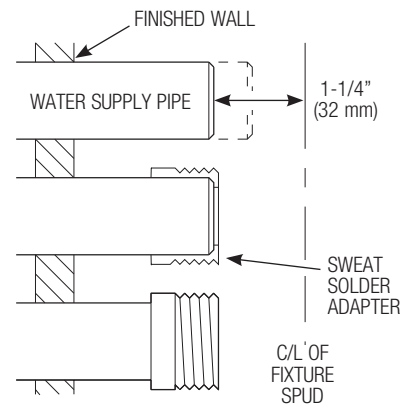

## 2 - INSTALL COVER TUBE, WALL FLANGE AND CONTROL STOP TO SUPPLY PIPE AND INSTALL VACUUM BREAKER FLUSH CONNECTION

- A** Measure from finished wall to first thread of adapter or threaded supply pipe (dimension "X"). Cut cover tube to this length.
- B** Slide cover tube over pipe. Slide wall flange over cover tube until against wall.
- C** Thread Control Stop onto pipe. Tighten with a wrench making sure outlet is positioned as required.

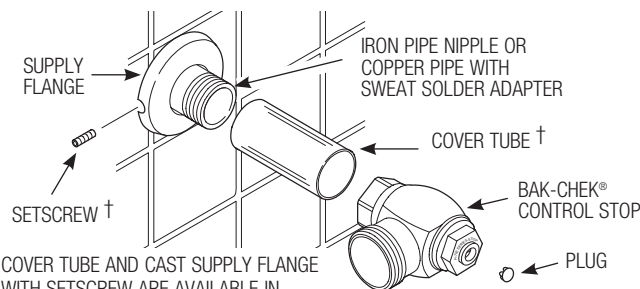
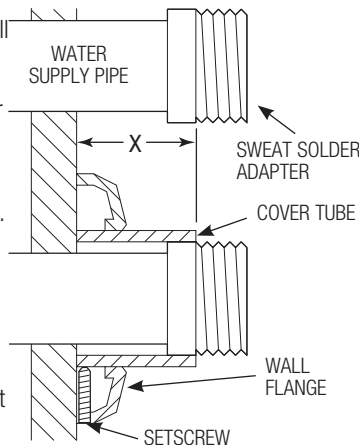

† COVER TUBE AND CAST SUPPLY FLANGE WITH SETSCREW ARE AVAILABLE IN "YBYC" SWEAT SOLDER KIT.

- D** Tighten setscrew with a 1/16" hex wrench. **DO NOT** install vandal resistant plug at this time.

- E** Slide spud coupling, nylon slip gasket, rubber gasket and spud flange over vacuum breaker tube.

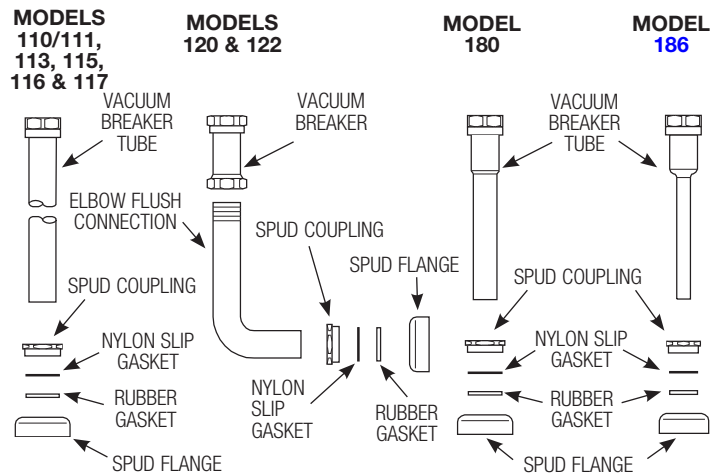

- F** Insert Tube into Fixture Spud.
- G** Hand tighten Spud Coupling onto Fixture Spud.

### 3 - INSTALL FLUSHOMETER AND HANDLE ASSEMBLY

**NOTE**

For high efficiency urinal flushometers (0.5, 0.25 and 0.125 gpf), it is necessary to first insert the flow control component into the tailpiece assembly. See the H1015A flow control kit and separate instructions for details on how to install.

- A** Lubricate tailpiece O-ring with water. Insert Adjustable Tailpiece into Control Stop. Tighten Tailpiece Coupling by hand.
- B** Align Flushometer directly above the Vacuum Breaker Flush Connection by sliding the Flushometer Body IN or OUT as needed. Tighten Vacuum Breaker Coupling by hand.



**NOTE**

Maximum adjustment of the Sloan Adjustable Tailpiece is 1/2" (13 mm) IN or OUT from the standard 4-3/4" (121 mm) (centerline of Flushometer to centerline of Control Stop).

If roughing-in measurement exceeds 5-1/4" (133 mm), consult factory for longer tailpiece.

- C** Align Flushometer Body. Using a wrench, securely tighten couplings in the order given: (1) Tailpiece Coupling, (2) Vacuum Breaker Coupling and (3) Spud Coupling.

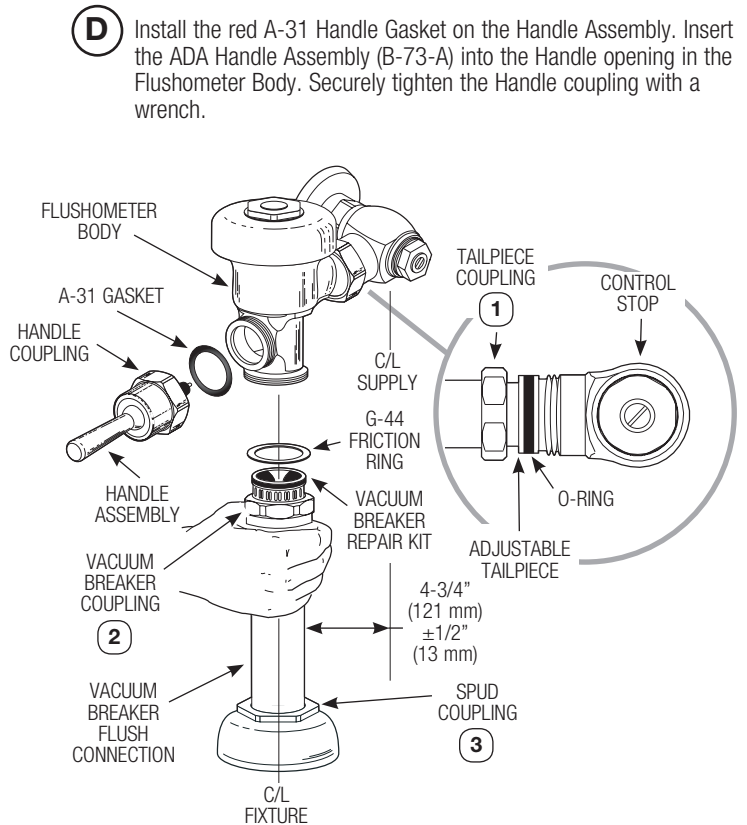

### 4 - FLUSH OUT SUPPLY LINE

- A** Make sure Control Stop is CLOSED and remove Flushometer Outer Cover.

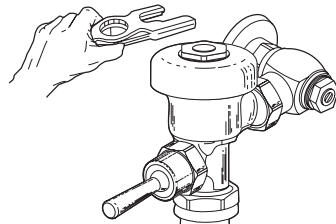
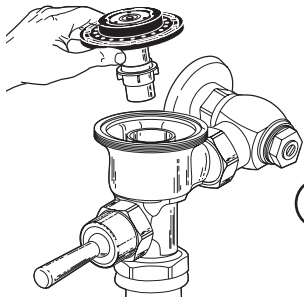

**CLOCKWISE CLOSSES CONTROL STOP**  
**COUNTERCLOCKWISE OPENS CONTROL STOP**

- B** Remove Inside Cover and lift out Inside Parts Assembly.

- C** Reinstall Outside and Inside Cover wrench tight. Open Control Stop to flush supply line. Close Control Stop and remove Outside and Inside Cover.

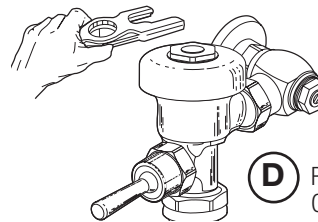

- D** Reinstall Inside Parts Assembly, Inside Cover and Outside Cover wrench tight.

### 5 - ADJUST CONTROL STOP AND INSTALL PLUG

- A** Open control stop COUNTERCLOCKWISE one FULL turn from closed position.

- B** Activate flushometer.

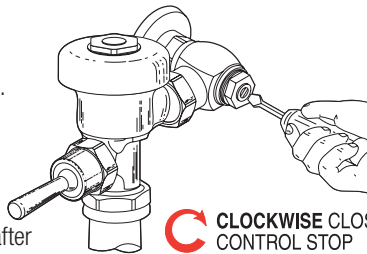

**CLOCKWISE CLOSSES CONTROL STOP**  
**COUNTERCLOCKWISE OPENS CONTROL STOP**

- C** Adjust control stop after each flush until the rate of flow delivered properly cleanses the fixture.

**!!! IMPORTANT !!!**

Sloan's flushometers are engineered for quiet operation. Excessive water flow creates noise, while too little water flow may not satisfy the needs of the fixture. Proper adjustment is made when the plumbing fixture is cleansed after each flush without splashing water out from the lip AND a quiet flushing cycle is achieved.

Never open Control Stop to where the flow from the valve exceeds the flow capability of the fixture. In the event of a valve failure, the fixture must be able to accommodate a continuous flow from the valve.

- D** Install plug into the control stop by pressing into bonnet.

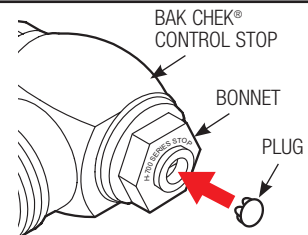

## CARE AND CLEANING

**DO NOT USE** abrasive or chemical cleaners (including chlorine bleach) to clean Flushometers that may dull the luster and attack the chrome or special decorative finishes. Use **ONLY** mild soap and water, then wipe dry with clean cloth or towel.

While cleaning the bathroom tile, protect the Flushometer from any splattering of cleaner. Acids and cleaning fluids will discolor or remove chrome plating.

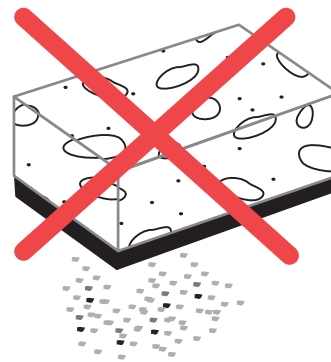

## TROUBLESHOOTING GUIDE

### I. Flushometer does not function (no flush).

- Control stop or main valve is closed. Open control stop or main valve.
- Handle assembly is damaged. Replace handle (B-32-A or B-73-A) or install handle repair kit (B-50-A).
- Relief valve is damaged. Replace inside parts kit.

### 2. Volume of water is not sufficient to siphon fixture.

- Control stop is not open wide enough. Adjust control stop for desired delivery of water volume.
- Urinal flushometer parts inside a closet flushometer. Replace inside urinal parts with proper closet flushometer parts.
- Low consumption flushometer installed on a non-low consumption fixture. Replace A-41-A inside parts kit with A-38-A water saver kit.
- Water saver kit installed in old, non-water saver bowl. Position refill head A-170 so that SIDE 1 is in the UP position.
- Inadequate volume or pressure at supply.
  - If no gauges are available to properly measure supply pressure or volume of water at the flushometer, then remove the relief valve from the inside parts kit, reassemble the flushometer and open the control stop. If the fixture siphons, more water volume is required. If a 3.5 gpf inside parts kit is installed in the flushometer, then first flip the refill head (under the diaphragm) to obtain a 4.5 gpf volume. If this volume is still inadequate, remove the flow ring from the guide to obtain a 6.5 gpf kit. If additional flow is still required, try a low pressure guide kit A-175-A (#0301104). **IMPORTANT — LAWS AND REGULATIONS PROHIBIT THE USE OF HIGHER FLUSHING VOLUMES THAN LISTED ON FIXTURE OR FLUSHOMETER.**
  - If fixture does not siphon or if a low consumption fixture is installed, or if the above steps do not prove satisfactory, steps must be taken to increase the pressure and/or supply.

### 3. Flushometer closes off immediately.

- Damaged diaphragm. Replace inside parts kit to correct problem.
- Enlarged by-pass orifice from corrosion or damage. Install inside parts kit to correct problem and update flushometer.

### 4. Length of flush is too short (short flush).

- Diaphragm assembly and guide assembly are not hand-tight. Screw the two assemblies hand-tight.
- Enlarged by-pass orifice from corrosion or damage. Install NEW Inside parts kit to correct problem and update flushometer.
- A-19-AU (Black) urinal relief valve in closet flushometer. Replace relief valve with A-19-AC (White) closet relief valve.
- A-41-A low consumption kit installed in non-low consumption fixture. Replace with proper Inside Parts Kit.
- Handle assembly is damaged. Replace handle (B-32-A or B-73-A) or install handle repair kit (B-50-A).

### 5. Length of flush is too long (long flushing) or fails to close off.

- Relief valve (A-19-A) is not seating properly or by-pass orifice is clogged because of foreign material, or by-pass orifice is closed by an invisible gelatinous film from "over-treated" water. Disassemble the working parts and wash thoroughly.

**NOTE: SIZE OF THE ORIFICE IN THE BY-PASS IS OF UTMOST IMPORTANCE FOR THE PROPER METERING OF WATER INTO THE UPPER CHAMBER OF THE FLUSHOMETER. DO NOT ENLARGE OR DAMAGE THIS ORIFICE. REPLACE INSIDE KIT IF CLEANING DOES NOT CORRECT PROBLEM.**

- Line pressure has dropped and is not sufficient to force Relief Valve to seat. Shut off all control stops until pressure has been restored, then open them again.
- A-19-AC (White) closet Relief Valve has been used in a 1 or 1½ gpf Urinal. Replace with A-19-AU (Black) Relief Valve.
- Inside cover is cracked or damaged. Replace the Inside Cover (A-71).

### 6. Chattering noise is heard during flush.

- Inside Cover is damaged. Replace Inside Cover (A-71).
- A-156-A Segment diaphragm has been installed upside-down. Reposition the Segment diaphragm properly (see markings on the Diaphragm).

### 7. Handle Leaks.

- B-39 Handle Seal is worn or damaged. Install new B-39 Seal.  
NOTE: The B-39 Seal will easily slide onto the B-40 Bushing when wet.
- Handle gasket has been omitted. Install Handle gasket (A-31) or Sloan handle repair kit (B-50-A).
- Valve handle bushing is worn. Replace handle repair kit (B-50-A).

When further assistance is required, please contact  
Sloan Technical Support at:

**1-888-SLOAN-14 (1-888-756-2614)**

or visit us online at:

**www.sloanvalve.com**

# PARTS LIST

Item No. No.	Part	Description
--------------	------	-------------

1	†	Valve Assembly
2A	B-73-A	ADA Compliant Handle Assembly
2B	A-31	Handle Gasket
3A	H-790-A	Bak-Chek® Control Stop
3B	H-528	Control Stop Bonnet Plug
4A	V-500-AA	1½" (38 mm) x 9" (229 mm) Vacuum Breaker Assembly ‡
4B	V-500-AA	1¼" (32 mm) x 9" (229 mm) Vacuum Breaker Assembly
4C	V-500-AA	¾" (19 mm) x 9" (229 mm) Vacuum Breaker Assembly
4D	V-500-A	Vacuum Breaker Assembly
5	F-109	1½" (38 mm) Elbow Flush Connection ‡
6A	F-56-A	1½" (38 mm) Spud Coupling Assembly
6B	F-57-A	1¼" (32 mm) Spud Coupling Assembly
6C	F-58-A	¾" (19 mm) Spud Coupling Assembly
7	F-7	Supply Flange (Supplied when Valve is Not Ordered with Sweat Solder Kit)
8	H-633-AA	1" (25 mm) Sweat Solder Kit and Cast Wall Flange with Setscrew
	H-636-AA	¾" (19 mm) Sweat Solder Kit and Cast Wall Flange with Setscrew

† Part number varies with valve model variation; consult factory  
 ‡ Length varies with valve model variation; consult factory

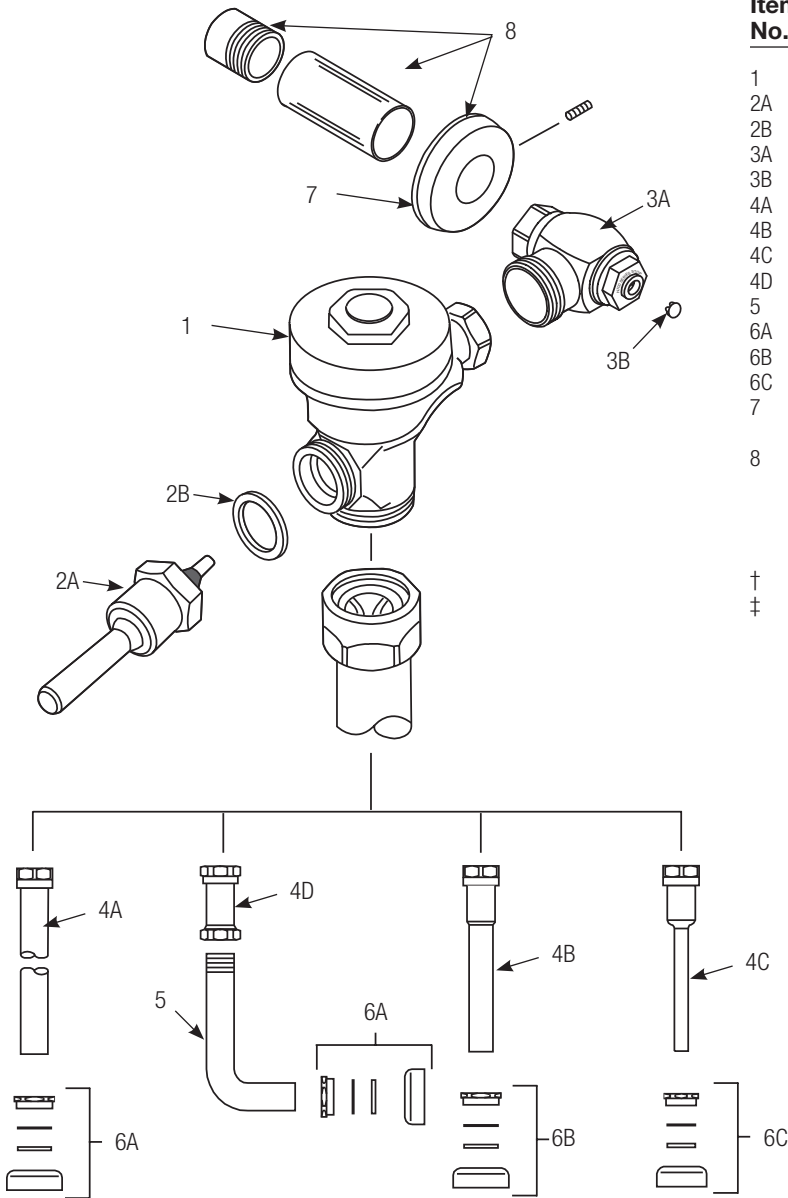

NOTE: The information contained in this document is subject to change without notice.

**SLOAN • 10500 SEYMOUR AVENUE • FRANKLIN PARK, IL 60131**

Ph: 1-800-982-5839 or 1-847-671-4300 • Fax: 1-800-447-8329 or 1-847-671-4380 • [www.sloanvalve.com](http://www.sloanvalve.com)