

INSTALLATION INSTRUCTIONS FOR OPTIMA® SYSTEMS SURFACE MOUNTED SENSOR ACTIVATED CONCEALED CLOSET AND URINAL FLUSHOMETERS

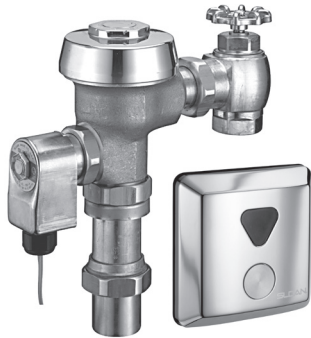

MODEL 150 ES-SM

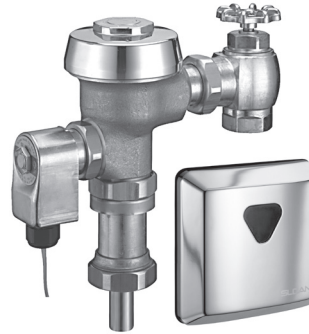

MODEL 194 ES-SM

Concealed Closet Flushometers

1" I.P.S. Outlet

- Model 150 ES-SM

1-1/2" Concealed Back Spud

- Model 152 ES-SM

Concealed Urinal Flushometers

1-1/4" Concealed Back Spud

- Model 190 ES-SM

3/4" I.P.S. Outlet

- Model 194 ES-SM

3/4" Concealed Back Spud

- Model 195 ES-SM



MODEL 152 ES-SM



MODEL 190 ES-SM



MODEL 195 ES-SM



LIMITED WARRANTY

Unless otherwise noted, Sloan Valve Company warrants this product, manufactured and sold for commercial or industrial uses, to be free from defects in material and workmanship for a period of three (3) years (one (1) year for special finishes, SF faucets, PWT electronics and 30 days for PWT software) from date of first purchase. During this period, Sloan Valve Company will, at its option, repair, replace, or refund the purchase price of any product which fails to conform with this warranty under normal use and service. This shall be the sole and exclusive remedy under this warranty. Products must be returned to Sloan Valve Company, at customer's cost. No claims will be allowed for labor, transportation or other costs. This warranty extends only to persons or organizations who purchase Sloan Valve Company's products directly from Sloan Valve Company for purpose of resale. This warranty does not cover the life of the batteries.

THERE ARE NO WARRANTIES WHICH EXTEND BEYOND THE DESCRIPTION ON THE FACE HEREOF. IN NO EVENT IS SLOAN VALVE COMPANY RESPONSIBLE FOR ANY CONSEQUENTIAL DAMAGES OF ANY MEASURE WHATSOEVER.

MODEL 150 ES-SM

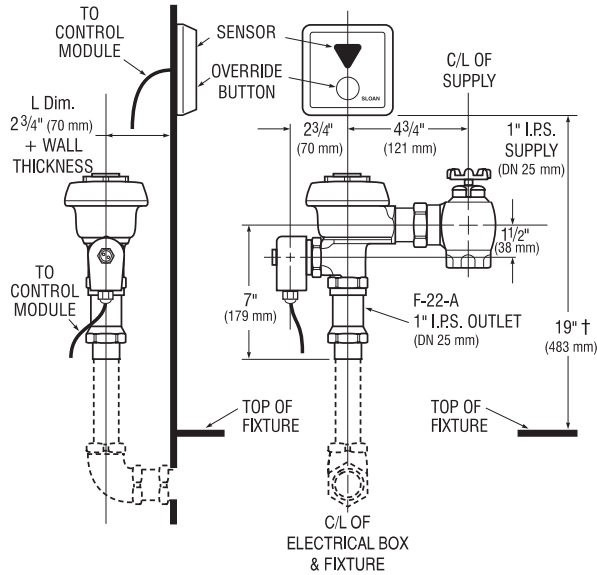

MODEL 152 ES-SM

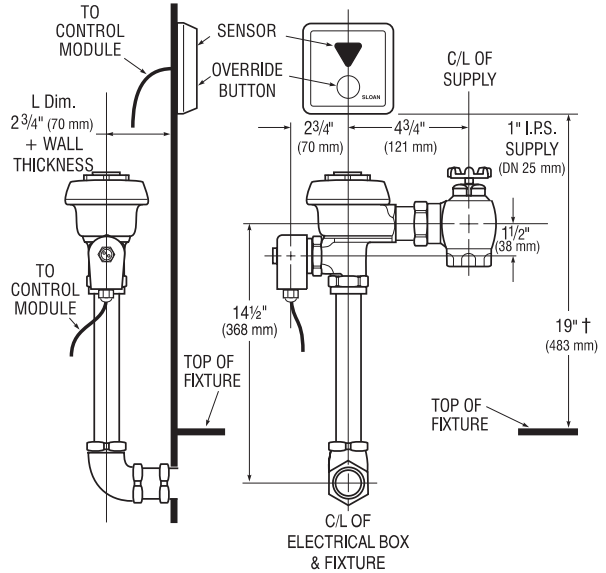

NOTE: Flush Connection shown with dotted lines is not included.

MODEL 190 ES-SM

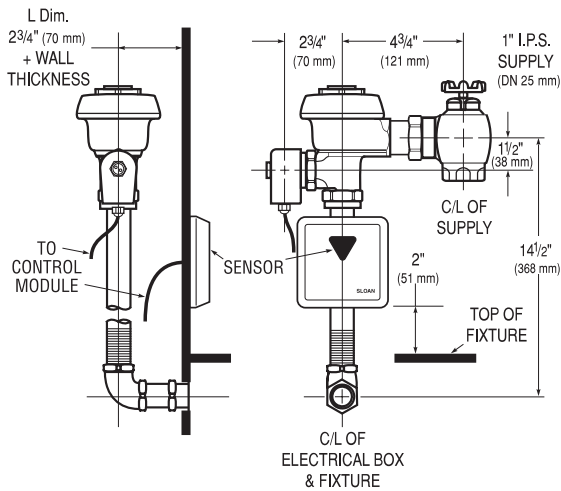

MODEL 194 ES-SM

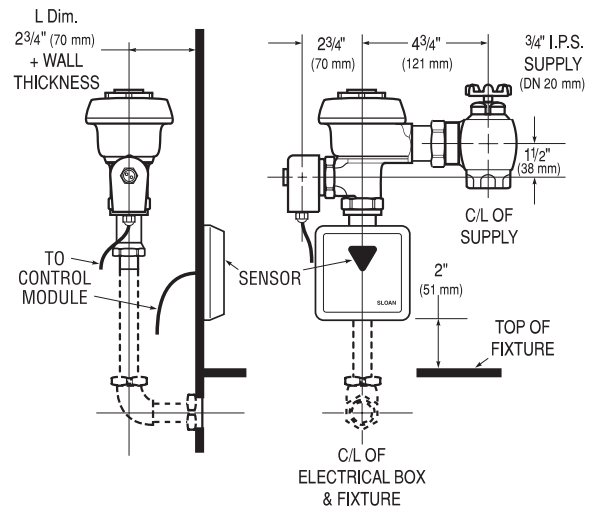

NOTE: Flush Connection shown with dotted lines is not included.

MODEL 195 ES-SM

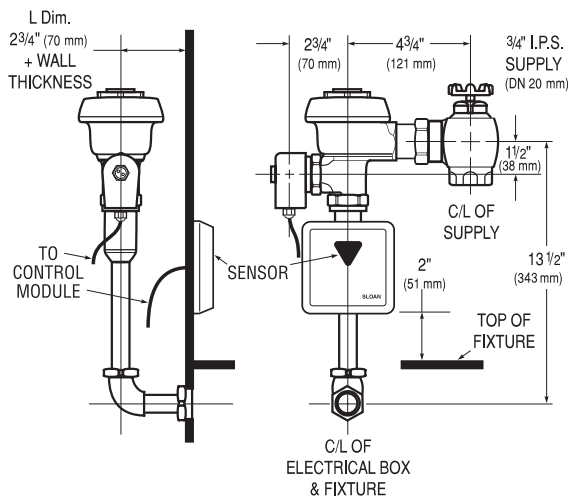

‡ POSITION OF SENSOR BOX CAN BE RAISED OR LOWERED 1" (25 mm) IF IN CONFLICT WITH HANDICAP GRAB BARS.

SENSOR LOCATION & POSITIONING IS CRITICAL!
 Failure to properly position the electrical boxes to the plumbing rough-in will result in improper installation and impair product performance. All tradesmen (plumbers, electricians, tile setters, etc.) involved with the installation of this product must coordinate their work to assure proper product installation.

PRIOR TO FLUSHOMETER INSTALLATION

Prior to installing the Sloan OPTIMA equipped Flushometer, install the items listed below. Refer to Rough-ins on Page 2 and illustration on this page.

- 2-gang electrical box — 4" x 4" x 2-1/2" (102 mm x 102 mm x 64 mm) for transformer; see paragraph entitled "Transformer Installation" (mount in a convenient location)
- Electrical wiring to the transformer box (120 VAC, 2 amp service required for each EL-154, 24 VAC, 50 VA transformer used)
- Closet/urinal fixture
- Drain line
- Water supply line

Important:

- **INSTALL ALL ELECTRICAL WIRING IN ACCORDANCE WITH NATIONAL/LOCAL CODES AND REGULATIONS.**
- **INSTALL ALL PLUMBING IN ACCORDANCE WITH APPLICABLE CODES AND REGULATIONS.**
- **WATER SUPPLY LINES MUST BE SIZED TO PROVIDE AN ADEQUATE VOLUME OF WATER FOR EACH FIXTURE.**
- **A 24 VAC STEP-DOWN TRANSFORMER MUST BE USED.**

- **USE APPROPRIATE PRECAUTIONS WHILE CONNECTING TRANSFORMER TO 120 VAC POWER SOURCE.**
- **FLUSH ALL WATER LINES PRIOR TO MAKING CONNECTIONS.**

Royal® and Sloan® Flushometers are designed to operate with 15 to 100 psi (104 to 689 kPa) of water pressure. **THE MINIMUM PRESSURE REQUIRED TO THE VALVE IS DETERMINED BY THE TYPE OF FIXTURE SELECTED.** Consult fixture manufacturer for minimum pressure requirements.

Most Low Consumption water closets (1.6 gallon/6.0 liter) require a minimum flowing pressure of 25 psi (172 kPa).

Protect the Chrome or Special finish of this Flushometer — **DO NOT USE TOOTHED TOOLS TO INSTALL OR SERVICE THE VALVE.** Also, see "Care and Cleaning" section of this manual.

IMPORTANT: EXCEPT FOR CONTROL STOP INLET, DO NOT USE PIPE SEALANT OR PLUMBING GREASE ON ANY VALVE COMPONENT OR COUPLING!

TRANSFORMER INSTALLATION AND SENSOR BOX LOCATION

Transformer Installation

Install Transformer (EL-154) on a 2-Gang Electrical Box, 4" x 4" x 2-1/2" (102 mm x 102 mm x 64 mm) in a convenient location; refer to the illustration at upper right side of this page.

Note: One Sloan EL-154 transformer can operate up to ten OPTIMA equipped Flushometers. Run 18-gauge wire from transformer to Flushometer(s). Wire supplied by others. DO NOT supply power to transformer until installation of Flushometer is complete.

Note: A maximum of ten (10) Flushometer units can operate from one (1) Sloan EL-154 Transformer, Class 2, UL Listed, 50 VA (min.) at 24 VAC, plate mounted.

Sensor Box Location

Failure to properly position the sensor to the plumbing rough-in will result in improper installation and impair product performance. All tradesmen (plumbers, electricians, tile setters, etc.) involved with the installation of this product must coordinate their work to assure proper product installation.

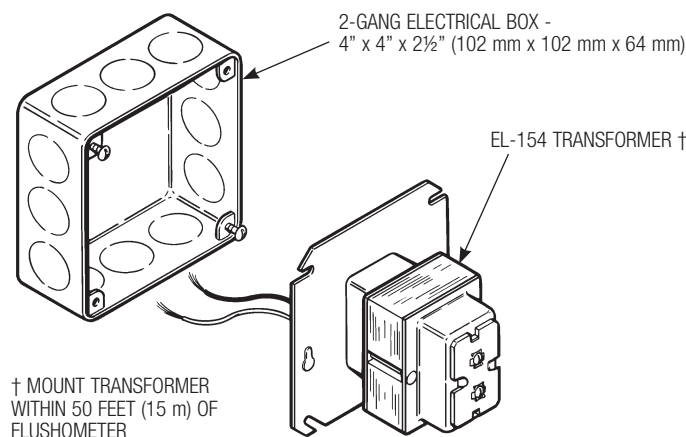

TOOLS REQUIRED FOR INSTALLATION

- Phillips screwdriver
- Drill – 1/16" and 1" drill bit
- Wire stripper
- Sloan A-50 Super-Wrench™, Sloan A-109 Plier Wrench or smooth jawed spud wrench

!!! IMPORTANT !!!

With the exception of Control Stop Inlet, DO NOT use pipe sealant or plumbing grease on any valve component or coupling!

!!! IMPORTANT !!!

Never open Control Stop to where the flow from the valve exceeds the flow capability of the fixture. In the event of a valve failure, the fixture must be able to accommodate a continuous flow from the valve.

!!! IMPORTANT !!!

This product contains mechanical and/or electrical components that are subject to normal wear. These components should be checked on a regular basis and replaced as needed to maintain the valve's performance.

!!! IMPORTANT !!!

Protect the chrome or special finish of Sloan Flushometers — **DO NOT USE toothed tools to install or service these valves.** Use a Sloan A-50 Super-Wrench™, Sloan A-109 Plier Wrench or smooth jawed spud wrench to secure all couplings. Also see "Care and Cleaning" section of this manual.

!!! IMPORTANT !!!

LAWS AND REGULATIONS PROHIBIT THE USE OF HIGHER FLUSHING VOLUMES THAN LISTED ON FIXTURE OR FLUSHOMETER.

If you have questions about how to install your flushometer, consult your local Sloan Representative or call Sloan Technical Support at: **1-888-SLOAN-14 (1-888-756-2614)**

1 - INSTALL OPTIONAL SWEAT SOLDER ADAPTER (ONLY IF YOUR SUPPLY PIPE DOES NOT HAVE A MALE THREAD)

- A** Slide Threaded Adapter fully onto pipe.
- B** Sweat solder the Adapter to pipe.

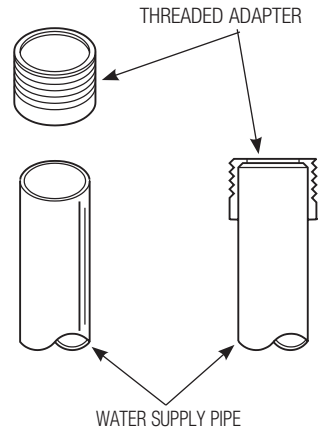

2 - INSTALL CONTROL STOP ONTO SUPPLY PIPE

- A** Install the Sloan Bak-Chek® control stop onto the water supply line with the outlet positioned as required.

!!! IMPORTANT !!!
WITH THE EXCEPTION OF THE CONTROL STOP INLET, DO NOT USE PIPE SEALANT OR PLUMBING GREASE ON ANY VALVE COMPONENT OR COUPLING!

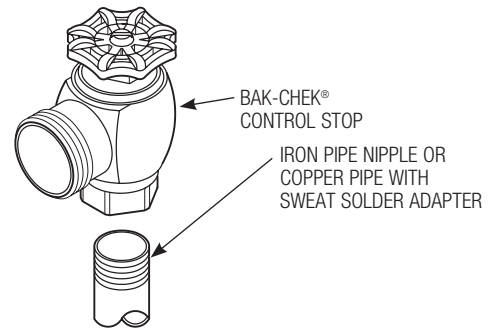

3 - INSTALL VACUUM BREAKER FLUSH CONNECTION

- A** Assemble pipe, elbows, couplings, nylon slip gasket, rubber gaskets and flanges as illustrated on parts page.
- B** Insert tube into fixture spud.
- C** Hand tighten all couplings.

IMPORTANT: WHEN CUTTING SCORED PIPE TO LENGTH LEAVE A MINIMUM OF 1-1/4" (32 mm) OF SCORING TO ENSURE PROPER ENGAGEMENT

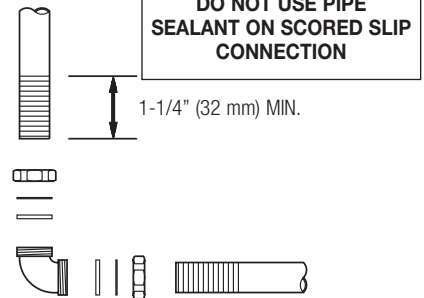

4 - INSTALL FLUSHOMETER

- A** Lubricate tailpiece o-ring with water. Insert adjustable tailpiece into control stop. Tighten tailpiece coupling by hand.
- B** Align flushometer directly above the vacuum breaker flush connection by sliding the flushometer body IN or OUT as needed. Tighten vacuum breaker coupling by hand.
- C** Align flushometer body and securely tighten first the tailpiece coupling **(1)**, then the vacuum breaker and pipe couplings **(2)**, and finally the spud coupling **(3)**. Use a wrench to tighten these couplings in the order shown.

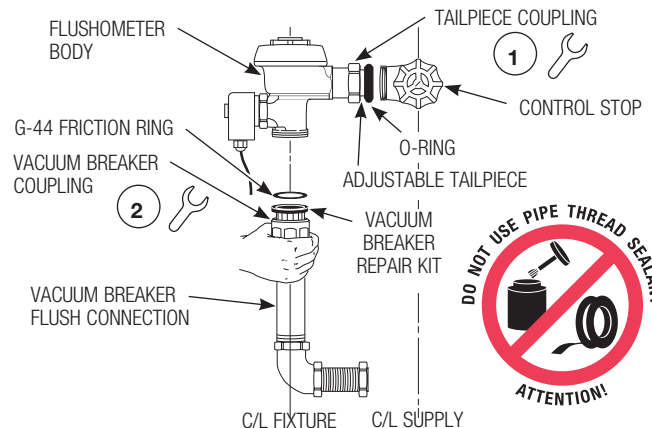

NOTE
Max. adjustment of Sloan Adjustable Tailpiece is 1/2" (13 mm) IN or OUT from the standard 4 3/4" (121 mm) (C/L of Valve to C/L of control stop).

If roughing-in measurement exceeds 5 1/4" (133 mm), consult factory for longer tailpiece.

5 - INSTALL SENSOR BOX

- A** Refer to page 2 rough-in drawings for the proper location of the sensor box. Position gasket (EL-456) onto finished wall in the sensor box location just determined. Using the gasket as a template, mark mounting holes and sensor box cable location.

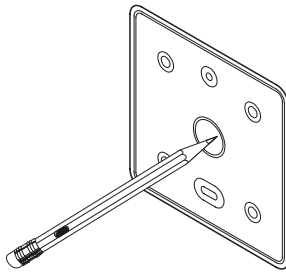

- B** Drill a 1/16" (1.6 mm) hole at the two mounting hole locations. Drill a 1" (25 mm) hole at the sensor box cable location.

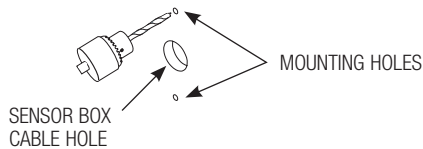

- C** Install an ETF-211 wall anchor in each mounting hole.

- D** Install gasket (EL-456) and wall bracket (EL-460) onto finished wall using two (2) #6 phillips screws. Ensure that sensor lens faces outward and horizontally from finished wall.

- E** Feed the 15-foot cord with RJ-11 plug through the wall bracket, gasket and 1" (25 mm) diameter hole.

- F** Install sensor cover plate and secure with screw.

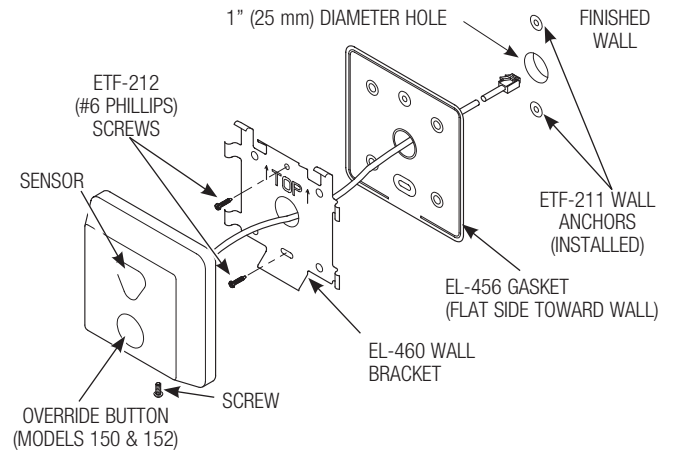

6 - ELECTRICAL HOOK-UP

- A** Be certain power is **OFF** to prevent damage to electrical components. Connect all cables EXACTLY as shown.

WATER CLOSET

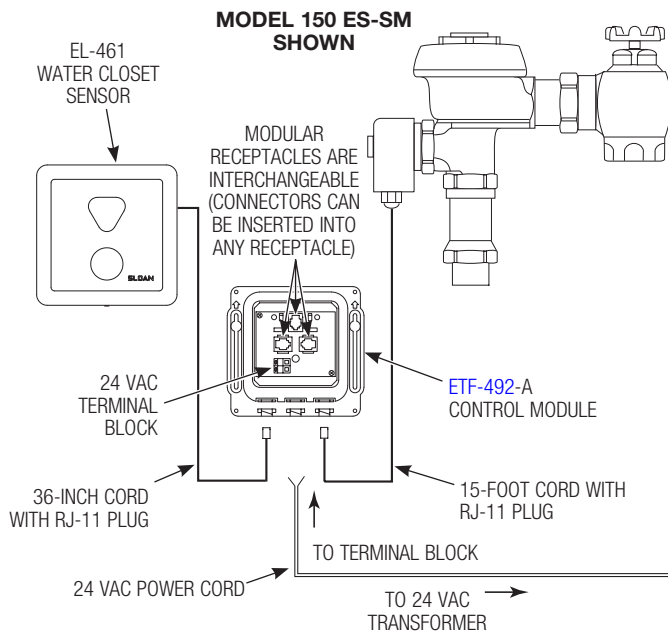

URINAL

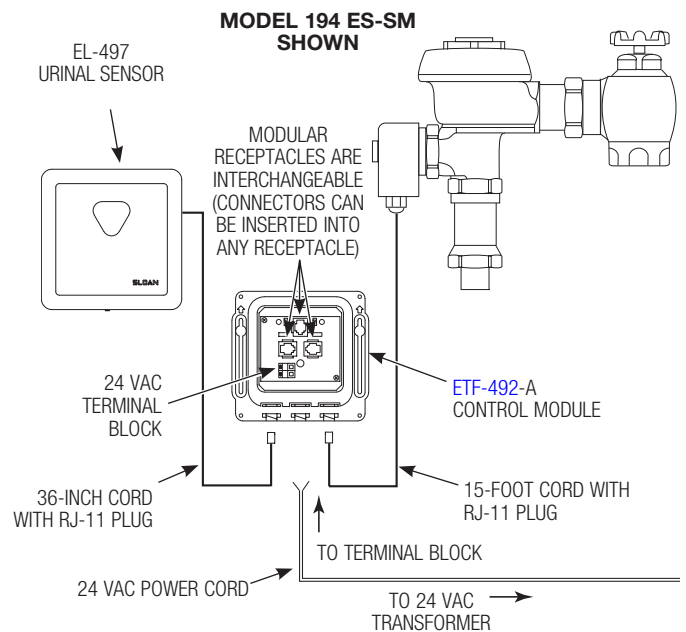

One 50 VA Transformer serves up to ten (10) OPTIMA closet/urinal flushometers. Specify number of transformers required accordingly.

7 - FLUSH OUT SUPPLY LINE

- A** Make sure Control Stop is CLOSED.
- B** Remove flushometer cover and lift out inside parts assembly. Install flushometer cover wrench tight.
- C** Open control stop. Turn on water supply to flush line of any debris or sediment.
- D** Shut off control stop, remove cover and reinstall inside parts assembly. Install flushometer cover wrench tight. **DO NOT** open control stop until Step 10.

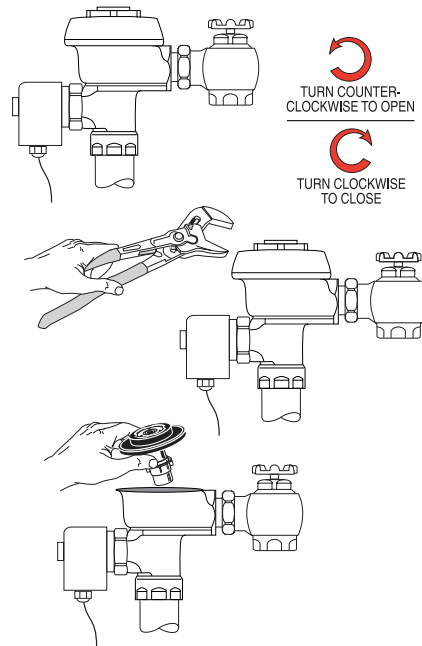

8 - POWER, START-UP MODE, AND ACTIVATION/DETECTION

Note: It is recommended that all electronic connections be tested with the water supply OFF.

- A** Turn Power **ON**. The self adaptive sensor automatically adapts to the surrounding environment when 24 volt supply is activated. No manual adjustments are required.
- B** Start-up mode will take approximately five (5) minutes to complete its cycle and is important that no non-permanent target is present at this time. A continuous red light visible in sensor window indicates sensor is in the start-up mode. If the red light is flashing, this indicates that the sensor is picking up a target. Unless this target is a permanent fixture in the sensor's environment (i.e., a wall or stall door), it must be removed from the view of the sensor. If this target is permanent, the sensor will adapt itself around this target. In this case, the start-up mode may take up to ten (10) minutes. When the start-up cycle is completed, no light is visible in sensor window.

Note: If 24 volt power supply is interrupted at any time for more than fifteen (15) seconds, the start-up mode automatically repeats itself when power is restored.

- C** The self-adaptive sensor is equipped with the sentinel flush feature (automatically flushes every twenty-four (24) hours after last use).
- D** When an object is detected, a steady flashing red light will appear in the sensor window. After approximately eight (8) to ten (10) seconds, the light will turn off indicating sensor is armed and ready to activate solenoid when the object leaves the detection area. The solenoid will be activated within two (2) to four (4) seconds after non-detection.



9 - TURN WATER ON AND ADJUST CONTROL STOP

- A** Adjust control stop to meet the flow rate required for proper cleansing of the fixture. Open control stop COUNTERCLOCKWISE 1/2 turn from the closed position.

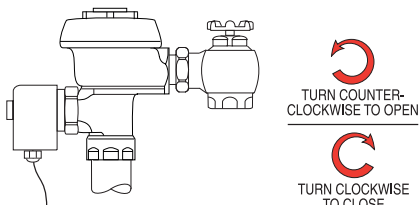

- B** Activate flushometer by placing hand in front of OPTIMA Sensor Lens for ten (10) seconds and then moving it away.

- C** Adjust control stop after each flush until the rate of flow delivered properly cleanses the fixture.

!!! IMPORTANT !!!

SLOAN FLUSHOMETERS ARE ENGINEERED FOR QUIET OPERATION. EXCESSIVE WATER FLOW CREATES NOISE, WHILE TOO LITTLE WATER FLOW MAY NOT SATISFY THE NEEDS OF THE FIXTURE. PROPER ADJUSTMENT IS MADE WHEN PLUMBING FIXTURE IS CLEANSSED AFTER EACH FLUSH WITHOUT SPLASHING WATER OUT FROM THE LIP AND A QUIET FLUSHING CYCLE IS ACHIEVED.

NEVER OPEN THE CONTROL STOP TO WHERE THE FLOW FROM THE VALVE EXCEEDS THE FLOW CAPABILITY OF THE FIXTURE. IN THE EVENT OF A VALVE FAILURE, THE FIXTURE MUST BE ABLE TO ACCOMMODATE A CONTINUOUS FLOW FROM THE VALVE.

OPERATION

1. A continuous, invisible light beam is emitted from the OPTIMA Sensor.

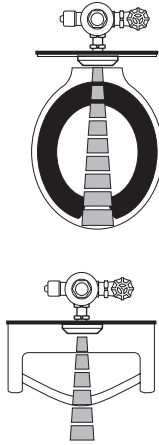

2. When a user enters the beam's effective range, the beam is reflected into the OPTIMA's scanning window and transformed into a low voltage electrical signal that activates a ten-second time delay circuit. The time delay circuit eliminates false operation from passers-by in the rest room. Once the time delay is completed, the output circuit is alerted and continues in a "hold" mode for as long as the user remains within the effective range of the sensor.

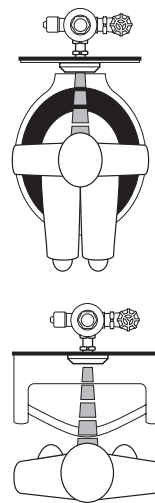

3. When the user steps away from the OPTIMA Sensor, the loss of reflected light initiates an electrical "one-time" signal that energizes the Solenoid Operator, and activates the Flushometer to flush the fixture. This occurs approximately three (3) seconds after indication. This delay is built into the Sensor to help prevent false flushing due to movement by the user. The circuit then automatically resets and is ready for the next user.

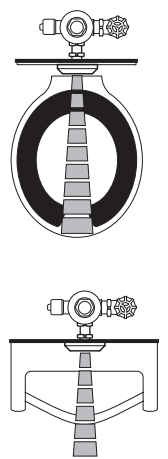

TROUBLESHOOTING GUIDE

NOTE: Upon detection of the user, the red indicator light is steadily on for a period of eight seconds. When the user leaves the detection range, the indicator light will turn off and the Sensor initiates the flush sequence. Then the indicator light stops flashing and the valve flushes. The valve will flush after a three-second delay.

- 1.PROBLEM:** Valve does not function (red light does not turn on when user steps in front of sensor).

CAUSE: No power is being supplied to sensor.

SOLUTION: Ensure that the main power is turned "ON." Check transformer, leads and connections. Repair or replace as necessary.

CAUSE: Sensor is not operating.

SOLUTION: Replace Sensor.

- 2.PROBLEM:** Valve does not function (red light flashes when user steps in front of Sensor).

INDICATOR: Red light stops flashing when user steps away and valve makes a "clicking" sound but does not flush.

CAUSE: No water is being supplied to the valve.

SOLUTION: Make certain that water supply is turned "ON" and the Control Stop is open.

CAUSE: EL-128-A cartridge is fouled or jammed.

SOLUTION: Turn electronic power to valve "OFF" (failure to do so could result in damage to the solenoid coil). Remove the solenoid operator from the valve and remove the EL-128-A cartridge. Clean and/or repair as necessary.

INDICATOR: The red light does not turn off when user steps away and the valve does NOT make a "clicking" sound and does NOT flush.

CAUSE: EL-163-A solenoid shaft assembly is fouled or jammed.

SOLUTION: Turn electronic power to valve "OFF" (failure to do so could result in damage to the solenoid coil). Remove EL-101 or EL-166 nut from the solenoid operator. Remove the coil from the solenoid operator. Use a spanner wrench or pliers to remove the EL-163-A solenoid shaft assembly from valve. Clean and/or replace as necessary. Be sure to replace plunger spring when reassembling Solenoid Shaft Assembly.

- 3.PROBLEM:** Volume of water is insufficient to adequately siphon fixture.

CAUSE: Control Stop is not open wide enough.

SOLUTION: Adjust control stop for desired water delivery.

CAUSE: Low Consumption unit is installed on Water Saver or Conventional fixture.

SOLUTION: Replace Diaphragm component parts of valve with kit that corresponds to appropriate flush volume of fixture.

CAUSE: Inadequate water volume or pressure available from supply.

SOLUTION: Increase pressure or supply (flow rate) to the valve. Consult factory for assistance.

- 4.PROBLEM:** Length of flush is too long (long flushing) or valve fails to shut off.

CAUSE: Water Saver valve is installed on Low Consumption fixture.

SOLUTION: Replace Diaphragm component parts of valve with kit that corresponds to appropriate flush volume of fixture.

CAUSE: Relief valve in diaphragm is not seated properly or bypass hole in diaphragm is clogged.

SOLUTION: Disassemble inside Diaphragm component parts and wash parts thoroughly. Replace worn parts if necessary.

- 5.PROBLEM:** Water splashes from fixture.

CAUSE: Supply flow rate is more than necessary.

SOLUTION: Adjust Control Stop to meet flow rate required for proper cleansing of the fixture.

When further assistance is required, please contact Sloan Technical Support at:

1-888-SLOAN-14 (1-888-756-2614).

!!! IMPORTANT !!!

LAWS AND REGULATIONS PROHIBIT THE USE OF HIGHER FLUSHING VOLUMES THAN LISTED ON FIXTURE OR FLUSHOMETER.

CARE AND CLEANING

DO NOT use abrasive or chemical cleaners (including chlorine bleach) to clean Flushometers as they may dull the luster and attack the chrome or special decorative finishes. Use **ONLY** soap and water, then wipe dry with clean cloth or towel.

While cleaning the bathroom tile, the Flushometer should be protected from any splattering of cleaner. Acids and cleaning fluids can discolor or remove chrome plating.

PARTS LIST

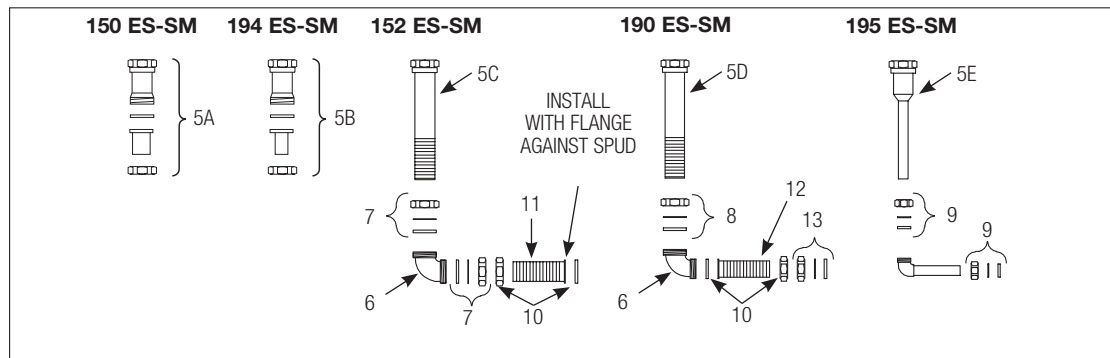
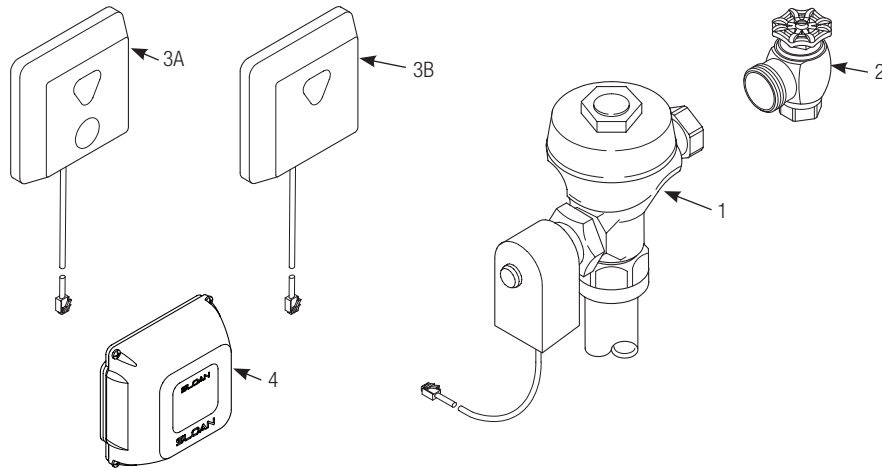

Item No.	Part No.	Description
1	‡	Solenoid Activated Valve Assembly
2	H-730-A	1" (25 mm) Concealed WH Bak-Chek® Angle Stop RB
3A	EL-461	¾" (19 mm) Concealed WH Bak-Chek® Angle Stop RB
3A	EL-461	Surface Mounted Sensor and Override Button Assembly (closet only)
3B	EL-497	Surface Mounted Sensor Assembly (urinal only)
4	ETF-492-A	Control Module
5A	V-500-A	1½" (38 mm) Vacuum Breaker Assembly RB (Model 150 ES-SM)
5B	V-500-A	¾" (19 mm) Vacuum Breaker Assembly RB (Model 194 ES-SM)
5C	V-500-A	1½" (38 mm) x 11½" (292 mm) Vacuum Breaker Assembly RB (Model 152 ES-SM)
5D	V-500-AA	1½" (38 mm) x 11½" (292 mm) Vacuum Breaker Assembly RB (Model 190 ES-SM)
5E	V-500-AA	¾" (19 mm) x 10½" (267 mm) Vacuum Breaker Assembly RB (Model 195 ES-SM)

Item No.	Part No.	Description
6	F-21	1½" (38 mm) Double Slip Elbow RB (Models 152 ES-SM and 190 ES-SM)
7	F-2-AA	1½" (38 mm) Slip Joint Coupling RB (Set of Two) (Model 152 ES-SM)
8	F-2-A	1½" (38 mm) Slip Joint Coupling RB (Model 190 ES-SM)
9	F-2-AW	¾" (19 mm) Slip Joint Coupling RB (Model 195 ES-SM)
10	F-2-A	1½" (38 mm) Coupling with S-21 Gasket
11	F-102	1½" (38 mm) Outlet Tube RB
12	F-110	1¼" (32 mm) O.D. Outlet Tube RB
13	F-2-AU	1¼" (32 mm) Slip Joint Coupling RB

‡ Part number varies with valve model variation; consult factory.

NOTE: The information contained in this document is subject to change without notice.

SLOAN HEADQUARTERS • 10500 SEYMOUR AVENUE • FRANKLIN PARK, IL 60131

Phone: 1-800-982-5839 or 1-847-671-4300 • Fax: 1-800-447-8329 or 1-847-671-4380 • www.sloanvalve.com