

SLOAN® Water Closet Installation Instructions

Water Connects Us®

THE RIGHT CHOICE

We thank you for your purchase. Our products are 100% tested but should you have any questions, please contact us by phone or at our web site.



⚠ WARNING: Any vitreous china can chip or break if the bolts or nuts are over-tightened or if mishandled.

BEFORE YOU START...

- Check all local plumbing and building codes.
- Check for any damage to the new water closet before installation.

WHAT YOU WILL NEED...

- Putty knife
- Safety glasses
- Measuring tape
- Spud wrench
- Sponge
- 10" adjustable wrench
- Large level
- Wax seal

NOTE: Plumbing System Requirements

- ✓ Minimum Flowing Pressure: 25 PSI
- ✓ Minimum Flow Rate: 25 GPM
- ✓ Maximum Static Pressure: 80 PSI

1. REMOVAL OF EXISTING WATER CLOSET

- Turn off the water supply.
- Disconnect the flush valve.
- Remove the existing water closet.

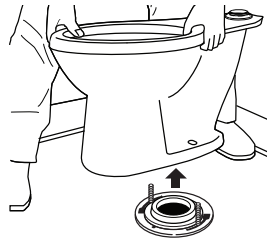

- Using putty knife, completely remove old wax seal from floor and bottom of water closet.
- Lay water closet down on padded surface to help protect the vitreous china.



⚠ WARNING: Hazardous gases can escape through the closet flange if new water closet is not installed quickly. A temporary fix: place a large rag in the closet flange.

NOTE: All vitreous china dimensions shown in these drawings are nominal. Dimensions can vary within the tolerances established in the governing ASME A112.19.2/CSA B45.1 standard. Please take this into consideration when planning rough-in and plumbing layouts.

2. INSTALLING NEW WATER CLOSET

- Check rough-in dimensions and install or relocate flush valve and outlet as indicated.
- Record model number for reference.
- Place and press in a new wax seal around the water closet bottom outlet.
- Install new 5/16" T-bolts.

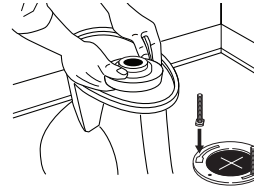

- Take out the temporary rag (if used) from the water closet flange hole.
- Carefully align and lower the water closet over the flange and T-bolts.

IMPORTANT! Do not lift or rock the water closet after replacement. The watertight seal will have to be replaced if breakage occurs.



- To seal, apply your full body weight around the water closet.
- Place the plastic cap base in the position indicated on cap as marked.
- The metal washers and nuts can now be placed on the bolt cap base and T-bolts.

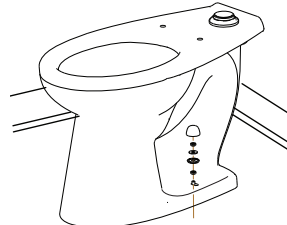

- Tighten the nuts carefully.



⚠ IMPORTANT! Do not overtighten the nuts, breakage and chipping of vitreous china can occur.

- Cut 1/4" or more over the top of the nut.
- Attach the bolt caps.

⚠ IMPORTANT! Product damage can occur if using a saw blade to cut off the excess T-bolt length. Make sure vitreous china is protected and covered.

3. COMPLETING THE INSTALLATION

- Flush valve should be installed to manufacturer's installation instructions.
- Turn on water supply valve.
- Install toilet seat (not included).

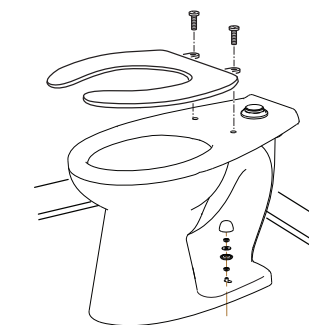

- Flush water closet a few times and check all connections for water seepage.
- Check for leaks.

CARE AND CLEANING OF VITREOUS CHINA

Clean water closet with a cleaner safe for vitreous china. Spray and wipe clean using soft cloth. Soft abrasive cleaners may be used to remove stains.

LIMITED WARRANTY

Sloan Valve Company warrants its products to be made of first class materials, free from defects of material or workmanship under normal use and to perform the service for which they are intended in a thoroughly reliable and efficient manner when properly installed and serviced, for a period of three years (one year for special finishes) from date of purchase. During this period, Sloan Valve Company will, at its option, repair or replace any part or parts which prove to be thus defective if returned to Sloan Valve Company, at customer's cost, and this shall be the sole remedy available under this warranty. No claims will be allowed for labor, transportation or other incidental costs. This warranty extends only to persons or organizations who purchase Sloan Valve Company's products directly from Sloan Valve Company for purpose of resale.

THERE ARE NO WARRANTIES WHICH EXTEND BEYOND THE DESCRIPTION ON THE FACE HEREOF. IN NO EVENT IS SLOAN VALVE COMPANY RESPONSIBLE FOR ANY CONSEQUENTIAL DAMAGES OF ANY MEASURE WHATSOEVER.

NOTE: IN NO EVENT SHALL THE SLOAN VALVE COMPANY BE LIABLE FOR INCIDENTAL DAMAGES, RESULTING FROM IMPROPER INSTALLATION, OR FOR DAMAGES CAUSED BY NEGLIGENCE, ABUSE OR ALTERATION.

The information contained in this document is subject to change without notice.

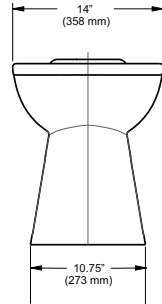
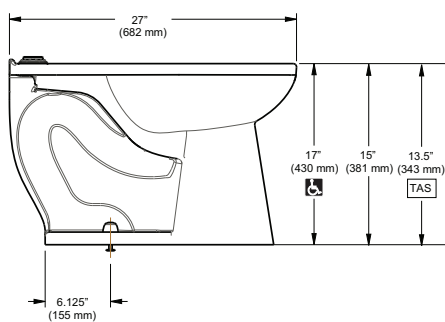
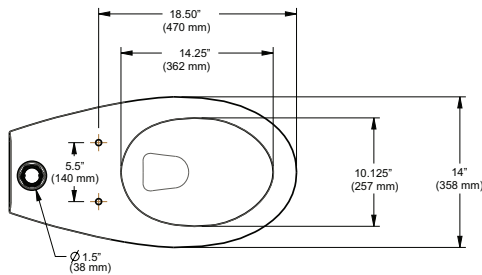

TO MAXIMIZE THE PERFORMANCE OF YOUR SLOAN WATER CLOSET, USE ONLY SLOAN FLUSHMETERS

SLOAN®

SLOAN

10500 Seymour Avenue
Franklin Park, IL 60131
Phone: 1-800-9-VALVE-9 (982-5839)
or 1-847-671-4300
Fax: 1-800-447-8329 or 1-847-671-4380
www.sloan.com

Copyright © 2017 Sloan Valve Company
Printed in the U.S.A.
Code No. 0816691 Rev.2 (03-17)