

INSTALLATION INSTRUCTIONS FOR EXPOSED GEM•2® AND GEM•2® XL PISTON TYPE WATER CLOSET AND URINAL FLUSHOMETERS

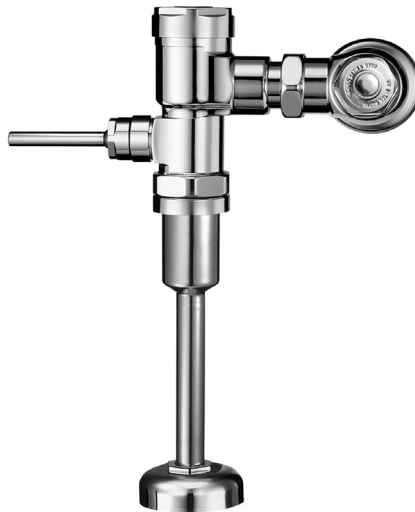

**Closet Flushometer for
1 1/2" Top Spud
MODELS
110/111, 113, 115 & 136**



**Urinal Flushometer for
1 1/4" Top Spud
MODEL 180
Urinal Flushometer for
3/4" Top Spud
MODEL 186**



**Closet Flushometer for
1 1/2" Back Spud
MODELS
120, 121, 122 & 137**

Made in the U.S.A.

LIMITED WARRANTY

Sloan Valve Company warrants its Gem•2® Flushometers to be made of first class materials, free from defects of material or workmanship under normal use and to perform the service for which they are intended in a thoroughly reliable and efficient manner when properly installed and serviced, for a period of three years (1 year for special finishes) from date of purchase. During this period, Sloan Valve Company will, at its option, repair or replace any part or parts which prove to be thus defective if returned to Sloan Valve Company, at customer's cost, and this shall be the sole remedy available under this warranty. No claims will be allowed for labor, transportation or other incidental costs. This warranty extends only to persons or organizations who purchase Sloan Valve Company's products directly from Sloan Valve Company for purpose of resale.

THERE ARE NO WARRANTIES WHICH EXTEND BEYOND THE DESCRIPTION ON THE FACE HEREOF. IN NO EVENT IS SLOAN VALVE COMPANY RESPONSIBLE FOR ANY CONSEQUENTIAL DAMAGES OF ANY MEASURE WHATSOEVER.

VALVE ROUGH-IN MODELS 110/111, 113, 115

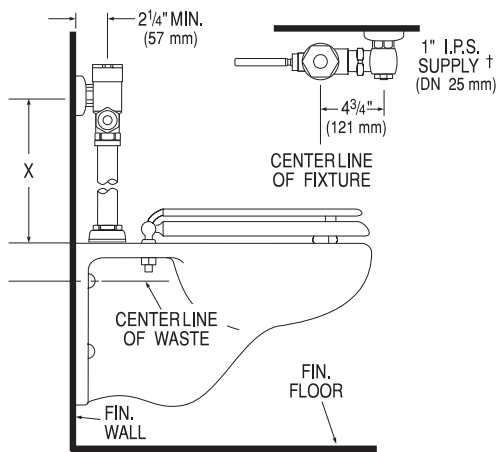

X = Model 110/111 - 11-1/2" (292 mm)
 Model 113 - 16" (406 mm)
 Model 115 - 24" (610 mm)

MODELS 120, 121, 122

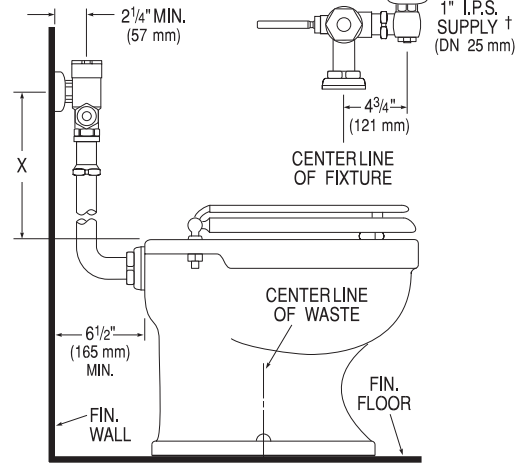

X = Model 120 — 11 1/2" (292 mm)
 Model 121 — 16" (406 mm)
 Model 122 — 24" (610 mm)

MODEL 136

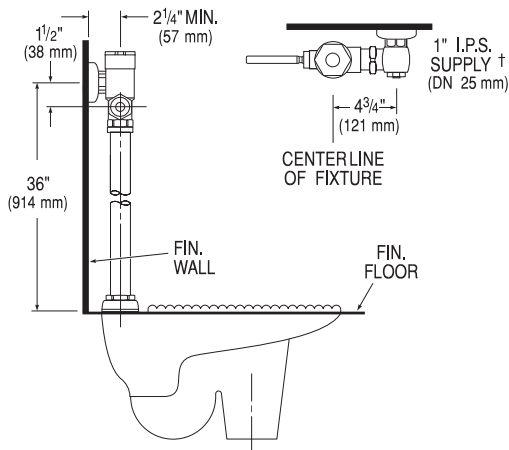

MODEL 137

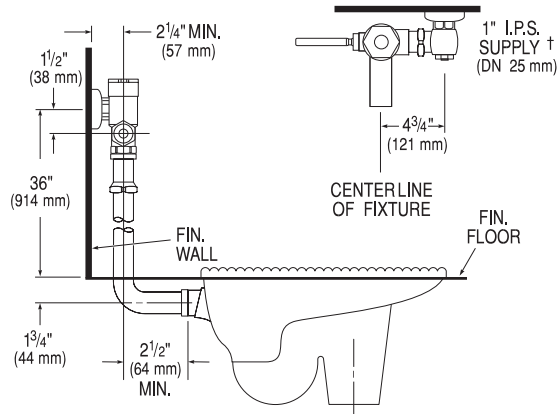

MODEL 180

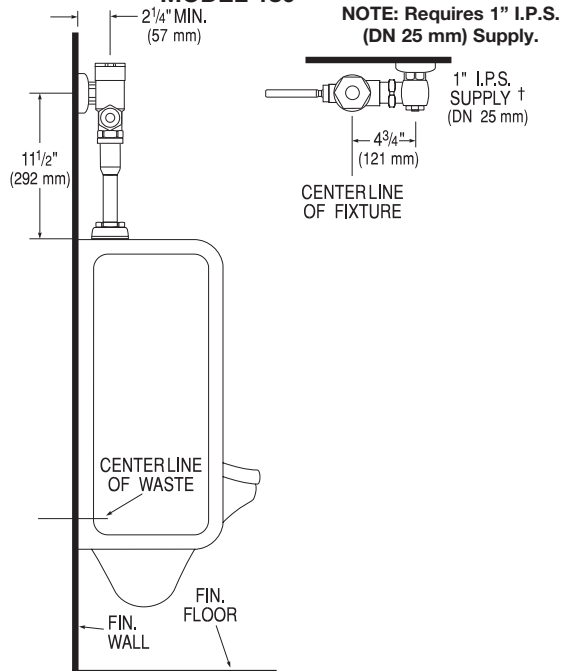

MODEL 186

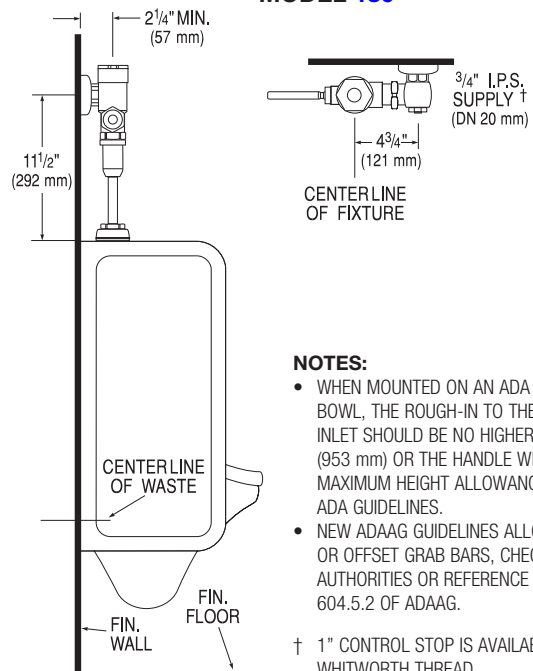

NOTES:

- WHEN MOUNTED ON AN ADA ACCESSIBLE BOWL, THE ROUGH-IN TO THE SUPPLY INLET SHOULD BE NO HIGHER THAN 37 1/2" (953 mm) OR THE HANDLE WILL EXCEED MAXIMUM HEIGHT ALLOWANCES UNDER ADA GUIDELINES.
- NEW ADAAG GUIDELINES ALLOW FOR SPLIT OR OFFSET GRAB BARS, CHECK WITH LOCAL AUTHORITIES OR REFERENCE SECTION 604.5.2 OF ADAAG.

† 1" CONTROL STOP IS AVAILABLE WITH WHITWORTH THREAD.

PRIOR TO INSTALLATION

Before you install the GEM•2® Flushometer, be sure the items listed below are installed. Also, refer to the rough-in diagram on Page 2.

- Closet/urinal fixture
- Drain line
- Water supply line

Important:

- ALL PLUMBING SHOULD BE INSTALLED IN ACCORDANCE WITH APPLICABLE CODES AND REGULATIONS.
- WATER SUPPLY LINES MUST BE SIZED TO PROVIDE AN ADEQUATE VOLUME OF WATER FOR EACH FIXTURE.
- WHEN INSTALLING A FLUSHOMETER, IT IS IMPORTANT THAT THE FLUSH MODEL MATCHES THE REQUIREMENTS OF THE PLUMBING FIXTURE.
- FLUSH ALL WATER LINES PRIOR TO MAKING CONNECTIONS.

The Sloan GEM•2® Flushometer is designed to operate with 10 to 100 psi (69 to 689 kPa) of water pressure. THE MINIMUM PRESSURE REQUIRED TO THE VALVE IS DETERMINED BY THE TYPE OF FIXTURE SELECTED. Consult fixture manufacturer for minimum pressure requirements. Most Low Consumption water closets require a minimum flowing pressure of 25 psi (172 kPa). Many building codes and the ASME A112.19.2 fixture standard list maximum static water pressure as 80 PSI.

TOOLS REQUIRED FOR INSTALLATION

- Straight blade screwdriver
- Sloan A-50 Super-Wrench™, Sloan A-109 Plier Wrench or smooth jawed spud wrench

!!! IMPORTANT !!!

With the exception of Control Stop Inlet, DO NOT use pipe sealant or plumbing grease on any valve component or coupling!

!!! IMPORTANT !!!

Never open Control Stop to where the flow from the valve exceeds the flow capability of the fixture. In the event of a valve failure, the fixture must be able to accommodate a continuous flow from the valve.

!!! IMPORTANT !!!

Protect the chrome or special finish of Gem•2 Flushometers — DO NOT USE toothed tools to install or service these valves. Use a Sloan A-50 Super-Wrench™, Sloan A-109 Plier Wrench or smooth jawed spud wrench to secure all couplings. Also see "Care and Cleaning" section of this manual.

!!! IMPORTANT !!!

This product contains mechanical and/or electrical components that are subject to normal wear. These components should be checked on a regular basis and replaced as needed to maintain the valve's performance.

If you have questions about how to install your Gem•2 Flushometer, consult your local Sloan Representative or call Sloan Installation Engineering Department at:

1-888-SLOAN-14 (1-888-756-2614)

1 Install Optional Sweat Solder Adapter (only if your supply pipe does not have a male thread)

- A** Measure from finished wall to C/L of Fixture Spud. Cut pipe 1¼" (32 mm) shorter than this measurement. Chamfer O.D. and I.D. of water supply pipe.
- B** Slide Threaded Adapter fully onto pipe.
- C** Sweat solder the Adapter to pipe.
-

!!! IMPORTANT !!!

With the exception of Control Stop Inlet, DO NOT use pipe sealant or plumbing grease on any valve component or coupling!

2 Install Cover Tube, Wall Flange and Control Stop to supply pipe

- A** Measure from finished wall to first thread of Adapter or threaded supply pipe (dimension "X"). Cut Cover Tube to this length.
- B** Slide Cover Tube over pipe. Slide Wall Flange over Cover Tube until against wall.
- C** Thread Control Stop onto pipe. Tighten with a wrench.
- D** Tighten Set Screw with a 1/16" hex wrench. **DO NOT** install Vandal Resistant Plug at this time.
-

3 Install Vacuum Breaker Flush Connection

- A** Slide Spud Coupling, Nylon Slip Gasket, Rubber Gasket and Spud Flange over Vacuum Breaker Tube.

MODELS 110/111, 115, 136 MODELS 120, 121, 122, 137 MODEL 180 MODEL 186

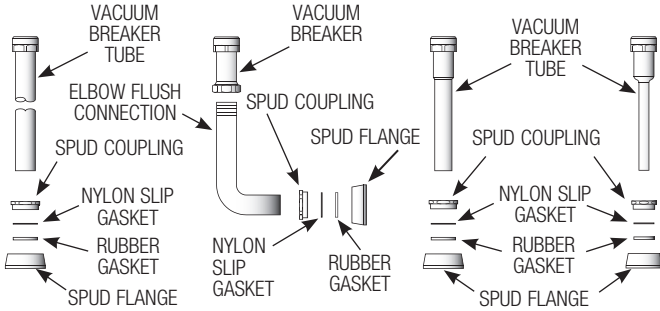

- B** Insert Tube into Fixture Spud.
C Hand tighten Spud Coupling onto Fixture Spud.

NOTE

On valves furnished less vacuum breaker (XYV Variation) connect flush tube to the bottom of the valve using the slip gasket supplied.

4A Install Flushometer

NOTE

For high efficiency urinal flushometers (0.5, 0.25 and 0.125 gpf), it is necessary to first insert the flow control component into the tailpiece assembly. See the H1015A flow control kit and separate instructions for details on how to install.

- A** Lubricate tailpiece O-ring with water. Insert Adjustable Tailpiece into Control Stop. Tighten Tailpiece Coupling by hand.
B Align Flushometer directly above the Vacuum Breaker Flush Connection by sliding the Flushometer Body IN or OUT as needed. Tighten Vacuum Breaker Coupling by hand.



NOTE

Maximum adjustment of the Sloan Adjustable Tailpiece is 1/2" (13 mm) IN or OUT from the standard 4-3/4" (121 mm) (centerline of Flushometer to centerline of Control Stop).

If roughing-in measurement exceeds 5-1/4" (133 mm), consult factory for longer tailpiece.

- C** Align Flushometer Body and securely tighten first the Tailpiece Coupling (1), then the Vacuum Breaker Coupling (2), and finally the Spud Coupling (3). Use a wrench to tighten these couplings in the order shown.
D If not installed, install Handle Assembly with Gasket to handle opening on Flushometer Body. Tighten Handle Assembly securely.

4B Install Flushometer (Continued)

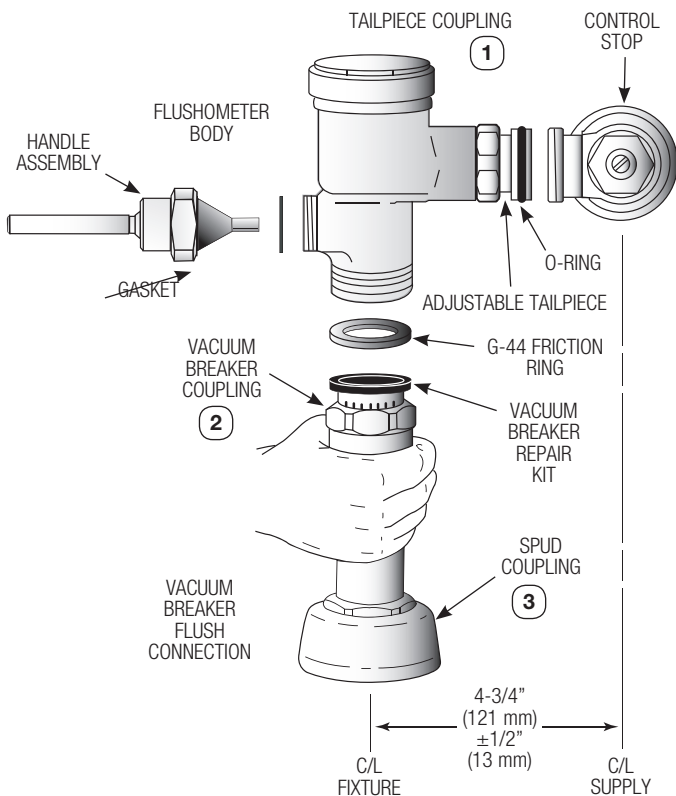

5 Flush Out Supply Line

- A** Make sure Control Stop is CLOSED and remove Flushometer Cover.
B Lift out Piston Assembly.
C Install Flushometer Cover wrench tight. Open Control Stop to flush supply line. Close Control Stop and remove Flushometer Cover.
D Reinstall Piston Assembly and Flushometer Cover. Tighten Flushometer Cover wrench tight.

6 Adjust Control Stop and Install Vandal Resistant Plug

- (A) Open Control Stop COUNTERCLOCKWISE 1/2 turn from closed position.
- (B) Activate Flushometer.
- (C) Adjust Control Stop after each flush until the rate of flow delivered properly cleanses the fixture.

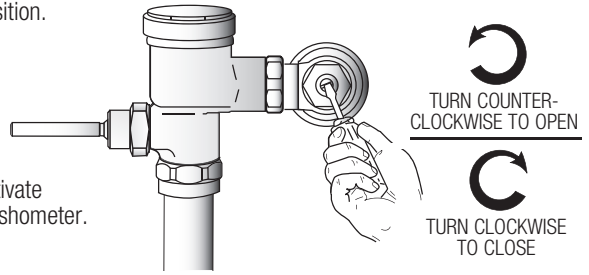

- (D) Install plug into the control stop by pressing into bonnet.

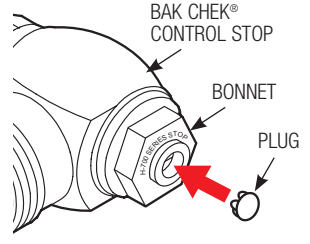

!!! IMPORTANT !!!

The Sloan Gem•2 Flushometer is engineered for quiet operation. Excessive water flow creates noise, while too little water flow may not satisfy the needs of the fixture. Proper adjustment is made when plumbing fixture is cleansed after each flush without splashing water out from the lip AND a quiet flushing cycle is achieved.

Never open Control Stop to where the flow from the valve exceeds the flow capability of the fixture. In the event of a valve failure, the fixture must be able to accommodate a continuous flow from the valve.

TROUBLESHOOTING GUIDE

- ### 1. Valve does not function (no flush).
- A. Control Stop or Main Valve is Closed. Open Control Stop or Main Valve.
 - B. Handle Assembly is worn. Replace Sloan Handle Assembly (G-143-A).
 - C. Relief Valve is worn and sticking in UP position. Replace Piston.
- ### 2. Volume of water is not sufficient to siphon fixture.
- A. Control Stop not open enough. Adjust Control Stop for desired delivery of water.
 - B. Urinal Piston Parts inside a Closet Flushometer. Replace Piston Parts with proper Closet Piston.
 - C. Low Consumption Flushometer installed on a non-Low Consumption fixture. Replace with proper Piston Kit.
 - D. Inadequate volume or pressure at supply. Increase water pressure or supply (flow) to Flushometer. Consult Factory for assistance.
- ### 3. Length of flush is too short (Short Flushing) or Flushometer closes off immediately.
- A. Piston Assembly is not hand-tight. Screw the assembly hand-tight.
 - B. Enlarged Bypass orifice from corrosion or damage. Install NEW Inside Piston Kit to correct problem and update Flushometer.
 - C. Urinal Piston in Closet Flushometer. Replace Piston with proper Closet Piston.
 - D. Low Consumption Piston installed in non-Low Consumption fixture. Replace Piston with proper Closet Piston.
 - E. Handle Assembly is worn. Replace Sloan Handle Assembly (G-143-A).
- ### 4. Length of flush is too long (Long Flushing) or fails to close off.
- A. Piston is not seating properly or Bypass orifice is clogged because of foreign material, or Bypass orifice is closed by an invisible gelatinous film from "over-treated" water.
Disassemble the working parts and wash thoroughly. NOTE: SIZE OF THE ORIFICE IN THE BYPASS IS OF UTMOST IMPORTANCE FOR THE PROPER METERING OF WATER INTO THE UPPER CHAMBER OF THE FLUSHOMETER. DO NOT ENLARGE OR DAMAGE THIS ORIFICE. REPLACE PISTON IF CLEANING DOES NOT CORRECT PROBLEM.
 - B. Line pressure has dropped and is not sufficient to force Relief Valve to seat. Shut off all control stops until pressure has been restored, then open them again.
 - C. 3.5 gpf Closet Piston has been used in a 1.0 or 1.5 gpf Urinal or on a 1.6 gpf Toilet. Replace with proper Piston.
 - D. G-21 Main Seat is fouled with debris or is worn. Clean or replace G-21 Main Seat.

5. Leaking at Handle Assembly.

- A. The B-39 Seal is worn or deteriorated. Install new B-39 Seal. NOTE: The B-39 Seal will easily slide onto the Bushing if it is wet.
- B. Handle gasket has been omitted. Replace Sloan Handle Assembly (G-143-A).
- C. Valve Handle Bushing is worn. Replace Sloan Handle Assembly (G-143-A).

Refer to the GEM•2 Flushometer Maintenance Guide for additional Troubleshooting and Repair Part information.

When assistance is required, please contact Sloan Valve Company Installation Engineering Department at:

1-888-SLOAN-14 (1-888-756-2614)

CARE AND CLEANING OF CHROME AND SPECIAL FINISHES

DO NOT use abrasive or chemical cleaners (including chlorine bleach) to clean Flushometers that may dull the luster and attack the chrome or special decorative finishes. Use ONLY mild soap and water, then wipe dry with clean cloth or towel.

While cleaning the bathroom tile, protect the Flushometer from any splattering of cleaner. Acids and cleaning fluids will discolor or remove chrome plating.

PARTS LIST

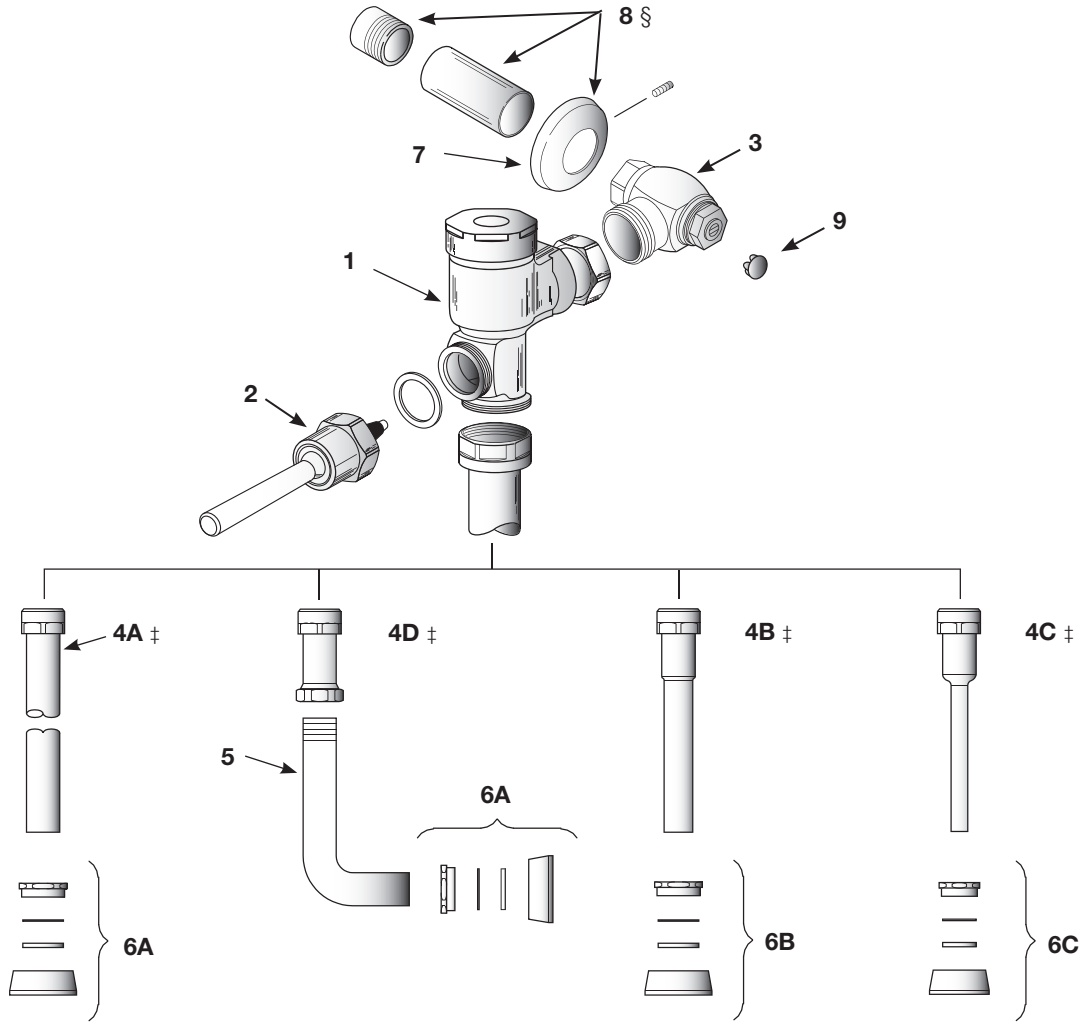

Item No.	Part No.	Description
1	†	Valve Assembly
2	G-143-A	Handle Assembly
3	H-700-A	Bak-Chek® Control Stop
4A	V-500-AA	1-1/2" (38 mm) x 9" (229 mm) Vacuum Breaker Assembly CP (Model 110/111) ‡
	V-500-AA	1-1/2" (38 mm) x 21-1/2" (546 mm) Vacuum Breaker Assembly CP (Model 115) ‡
4B	V-500-AA	1-1/4" (32 mm) x 9" (229 mm) Vacuum Breaker Assembly CP (Model 180) ‡
4C	V-500-AA	3/4" (19 mm) x 9" (229 mm) Vacuum Breaker Assembly CP (Model 186) ‡
4D	V-500-A	1-1/2" (38 mm) Vacuum Breaker Assembly CP ‡

Item No.	Part No.	Description
5	F-109	1-1/2" (38 mm) Elbow Flush Connection
6A	CR-1010-A	1-1/2" (38 mm) Spud Coupling Assembly (Models 110/111, 115, 120, 121 & 122)
6B	CR-1009-A	1-1/4" (32 mm) Spud Coupling Assembly (Model 180)
6C	CR-1008-A	3/4" (19 mm) Spud Coupling Assembly (Model 186)
7	F-7	Supply Flange (Supplied when Valve is Not Ordered with Sweat Solder Kit)
8	H-633-AA	1" (25 mm) Sweat Solder Kit with Cast Set Screw Flange (XL Models) §
	H-636-AA	3/4" (19 mm) Sweat Solder Kit with Cast Set Screw Flange (XL Models) §
9	H-528	Control Stop Bonnet Plug

† Part number varies with valve model variation; consult factory.

‡ If valve was specified less vacuum breaker (XYV variation), a straight flush tube is supplied in place of the vacuum breaker assembly. Consult Factory for part number.

§ Furnished only when ordered with XL Version.

For a complete listing of GEM•2 Flushometer Valve Components and Repair Kits, refer to the Maintenance Guide or consult your nearest plumbing wholesaler. For optimum water conservation and Flushometer performance, use only Genuine Sloan Parts.

NOTICE: The information contained in this document is subject to change without notice.