

SloanStone® EWF-40000 Sink



EW-42000, EW-43000 AND EW-44000 PARTS

Item No.	Code No.	Part No.	Description
1A.	—	—	Actuator Housing Assembly Cover (double station)
1B.	—	—	Actuator Housing Assembly Cover (triple station)
1C.	—	—	Actuator Housing Assembly Cover (quadruple station)
2.	—	—	Sensor
3A.	—	—	Actuator Housing Assembly (double station)
3B.	—	—	Actuator Housing Assembly (triple station)
3C.	—	—	Actuator Housing Assembly (quadruple station)
4.	—	—	Spray Head
5.	—	—	Strainer
6.	—	—	1½" Drain Spud
7A.	—	—	Solid Surface Basin (double station)
7B.	—	—	Solid Surface Basin (triple station)
7C.	—	—	Solid Surface Basin (quadruple station)
8.	—	—	Washer
9.	—	—	Locknut
10A.	—	—	Pedestal (double station)
10B.	—	—	Pedestal (triple station)
10C.	—	—	Pedestal (quadruple station)
11A.	—	—	Solid Surface Access Cover (double station)
11B.	—	—	Solid Surface Access Cover (triple station)
11C.	—	—	Solid Surface Access Cover (quadruple station)

MIXING VALVE

0326045	MIX-135-A	Below Deck Thermostatic Water Mixing Valve (BDT Variation)
----------------	-----------	--

REPAIR KITS

3305622	EL-1500-LL	Sensor – Lavatory
3305527	ETF-1004-A	Solenoid
3305577	ETF-1009-A	Solenoid Valve Repair Kit

— Consult factory for replacement part.
 — Consult factory for replacement part.

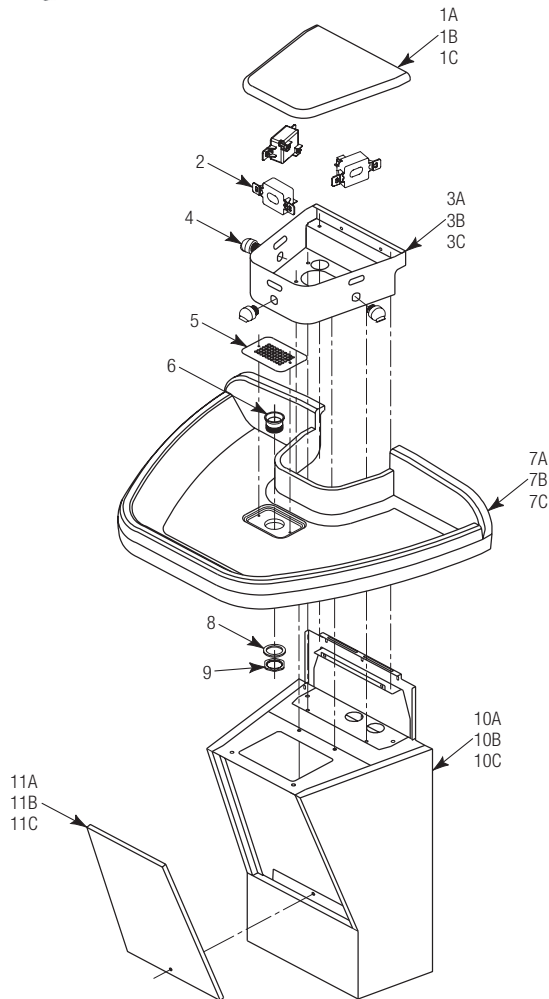

SloanStone® EWF-40000 Sink

TROUBLESHOOTING GUIDE

1. No water flows when sensor is activated

Ensure that main power supply is turned "ON." Check receptacle, transformer, solenoid, leads and connections.

INDICATOR: If Sensor LED does not blink:

- A. Control module circuit board is faulty; replace.
- B. Sensor is faulty; replace sensor module.

INDICATOR: If Sensor LED blinks when user is sensed:

- A. Supply Stop(s) may be closed; open Supply Stop(s).
- B. Debris may be in Solenoid filter; remove, clean and reinstall.

2. Very low flow or slow dribble

- A. Supply Stop(s) may be closed; open Supply Stop(s).
- B. Debris is in solenoid, won't close properly; remove operator and clean. Reassemble in the same manner.
- C. Debris may be in Solenoid filter; remove, clean and reinstall.
- D. Debris is in spray head; remove, clean and reinstall.

3. Continues to run (even after power to faucet has been disconnected)

- A. Solenoid valve is installed backwards; install correctly.
- B. Debris is in solenoid, won't close properly; remove operator and clean. Reassemble in the same manner.

SOLENOID SCREEN FILTER CLEANING

- A. Before cleaning the Screen Filter, turn off the water supply at supply stop(s).
- B. Activate the Spray Head to relieve any pressure in the system.
- C. Unscrew the Filter Cap and remove it from the Solenoid Valve Housing.
- D. Carefully remove the Screen Filter from the Solenoid Valve Housing.
- E. Clean the Screen Filter using fresh tap water only. If necessary, use a small brush to clean. Use caution while cleaning to prevent damage to Screen Filter.
- F. Examine the Copper Washer for wear or damage; replace if necessary. Carefully replace the Screen Filter into the Filter Cap. Screw the Filter Cap with Copper Washer into the Solenoid Valve Housing and tighten securely to prevent leaks.
- G. Turn on the water supply at the supply stop(s). Activate the Spray Head to purge any air from the system lines. Check for leaks and repair as necessary.

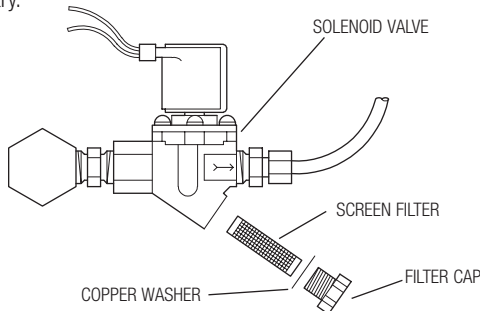

SloanStone® Solid Surface Care

For normal cleaning, use warm, soapy water or conventional ammonia based liquid glass cleaner.

For dry stains, allow the soapy water or glass cleaner some time to remoisturize the area, then wipe the stain off.

To renew the surface after deep scratches or stains, use green, then maroon, and finally white 3M Scotch-Brite® pads to return the deck to a smooth 1200 grit wet-sanded finish.

If the dry stain is neither water-based nor oil-based, gently scrape the stain off with a plastic material (i.e. a plastic knife), and then proceed with the aforementioned normal cleaning procedures.

Wipe the entire surface evenly with a mild abrasive cleanser for regular maintenance.

Stainless Steel Care

Important: When cleaning stainless steel, always rub in the same direction of the stainless steel finish lines, never across. After cleaning, always thoroughly rinse with water and dry all cleaned stainless steel areas to prevent buildup of mineral deposits.

Clean stainless steel surfaces often using warm, soapy water.

For more stubborn deposits, use baking soda, borax or any of several non-abrasive commercial cleansing agents. Do not leave chlorides found in most cleansing agents for extended periods of time on the surfaces as they may attack stainless steel. If an abrasive cleaning tool is needed, always use stainless steel wool, stainless steel pads, or stainless steel brushes. Do not use ordinary steel wool, pads or brushes because they have a tendency to break apart and leave small particles which will rust on the stainless steel surfaces, giving the appearance that the stainless steel surfaces themselves are rusting. Do not use strong acidic or caustic cleaners or cleansers because they may also attack the stainless steel surfaces. Maintain a regular cleaning schedule.

**When assistance is required, please contact
Sloan Technical Support at: 1-888-SLOAN-14 (1-888-756-2614).**