

SloanStone® EW-72000 Sink Head Assembly

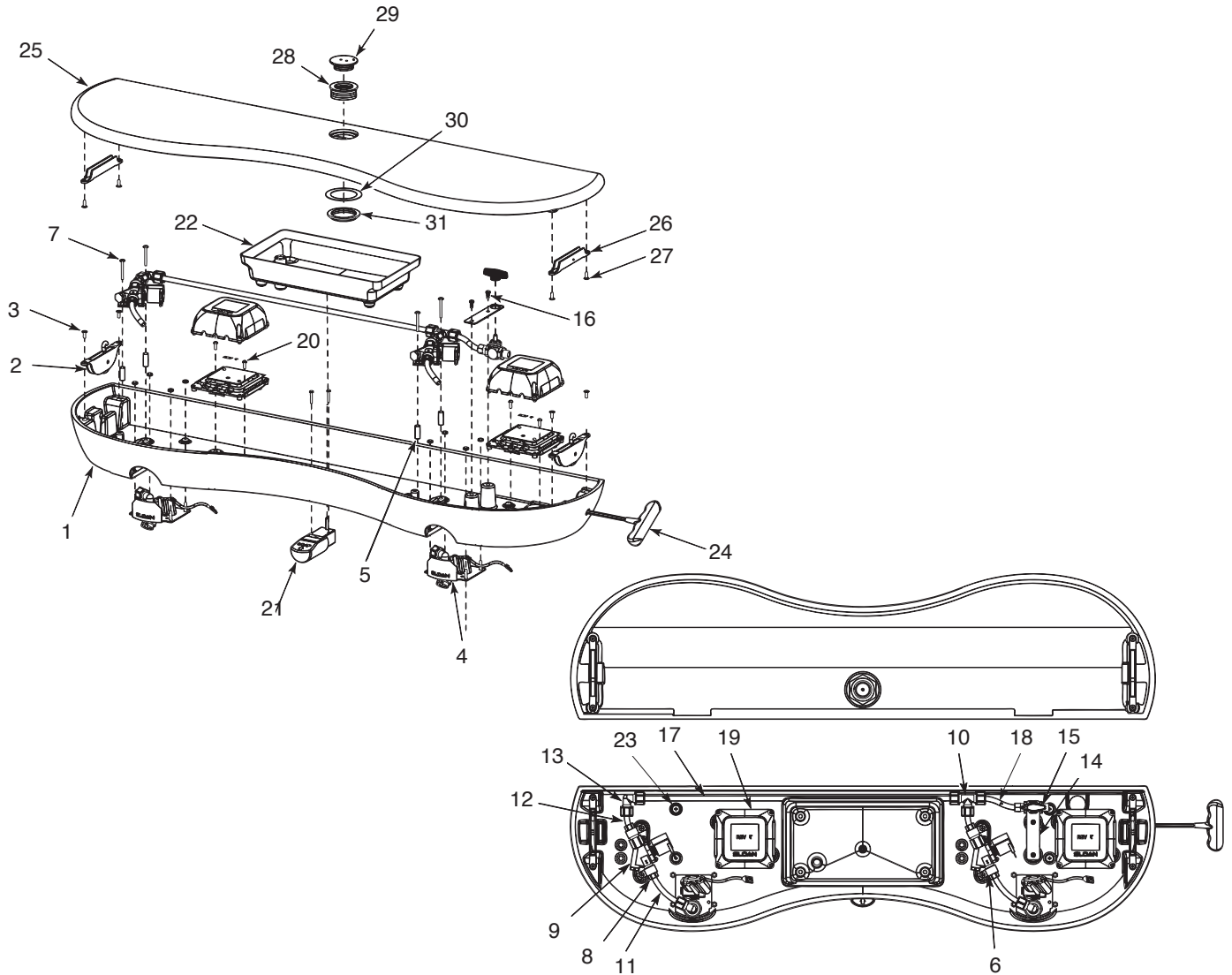

Item No.	Part No.	Description
1.	EW-46	Electronics Enclosure 2 Station Machined
2.	EW-41	Large Latch (2)
3.	EW-27	Screw, Flat Head #10-24 x 1/2" Long (4)
4.	EW-75-A	Sensor Plate Assembly (2)
5.	EW-8	Spacer, #8 x 1" Long (4)
6.	EW-13	Mounting Clamp for ETF-370-A Solenoid (4)
7.	EW-9	Screw, Truss Head #8-32 x 1-1/2" Long (4)
8.	ETF-61	Male Connector (4)
9.	ETF-370-A	Solenoid Valve Assembly (2)
10.	EW-19	Compression Tee Fitting 3/8" Tube
11.	EW-89-00362	Tube, 3/8" x 3-5/8" Long (2)
12.	EW-89-00188	Tube, 3/8" x 1-7/8" Long (2)
13.	EW-18	Compression Elbow Fitting, 3/8" Tube
14.	EW-5	Mounting Bracket for Shut-off Valve
15.	EW-74	Panel Mount Ball Valve - 3/8" Compression Fitting
16.	EW-36	Screw, Pan Head #8-32 x 7/16" Long (SEMS)(2)
17.	EW-89-02525	Tube, 3/8" x 25-1/4" Long
18.	EW-89-00388	Tube, 3/8" x 3-7/8" Long
19.	ETF-450-A	Splash Proof Junction Box Assembly (2)
20.	EW-28	Screw, Round Head #8-32 x 1/2" Long (4)
21. †	ESD-255-A	Manual Soap Pump Assembly

Item No.	Part No.	Description
22. †	ESD-245-A	Manual Soap Reservoir Assembly
23.	EW-37	Screw, Truss Head 1/4-20 x 1-1/2" (4)
—	EW-26	Tube Support 3/8" (5) (Not Shown)
—	MIX-135-A	Thermostatic Mixing Valve (Below Deck) (Not shown)
—	EW-87	Flexible Supply Hose, 2 Station (Not Shown)
—	EW-82-A	Wiring Harness, 2 Station (Not Shown)
—	ETF-233	Transformer (Not shown)
—	ETF-731	Vandal Proof Key, Standard and Junior (Not shown)
24.	EW-96	T-Handle Hex Wrench, 7/32"
25.	EW-48-X	Cover, Electronics Enclosure, 2 Station Machined
26.	EW-42	Large Encased Receiver (2)
27.	EW-27	Screw, Flat Head #10-24 x 1/2" Long (4)
28. ‡	ESD-242	Sleeve for Fill Cap
29. ‡	ESD-241	Fill Cap for Soap Reservoir
30. ‡	EW-11	Gasket - Fill Cap Sleeve (Manual Soap Reservoir)
31. ‡	ESD-243	Jam Nut for Fill Cap Sleeve
— ‡	ESD-249	Fill Cap Spanner (Not Shown)

† Included on models with Soap Dispenser.
‡ Included on models with Fill Cap.

The information contained in this document is subject to change without notice.

**SloanStone® EW-72000 Sink
Cabinet and Basin Assembly**

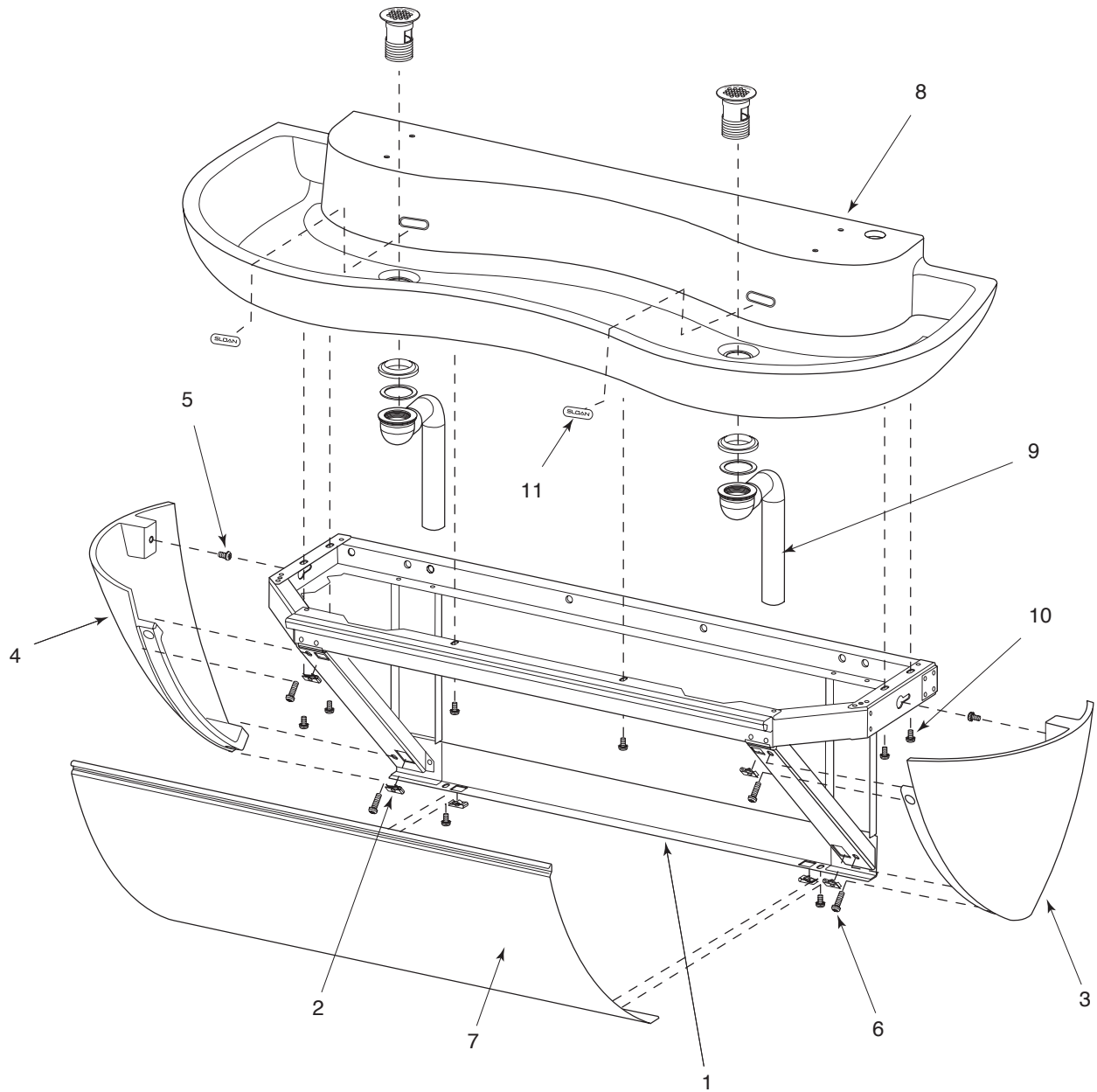

Item No.	Part No.	Description
1.	EW-20-A	Cabinet Weldment, 2 Station
2.	EW-99	U-Type Nut Standard 1/4-20 Thread (6)
3.	EW-60	End Cap Right - Machined
4.	EW-52	End Cap Left - Machined
5.	EW-15	Screw, Pan Head 1/4-20 x 1/2" Long (SEMS) (4)
6.	EW-16	Screw, Pan Head 1/4-20 x 1" Long (SEMS) (4)
7.	EW-25	Front Panel, 2 Station

Item No.	Part No.	Description
1.	EW-44	Basin 2-Station Machined
2.	ETF-725-A	Grid Strainer Assembly (2)
3.	EW-15	Screw, Pan Head 1/4-20 x 1/2" Long (SEMS) (6)
4.	EW-61	Overflow Cover Plate (2)
		— EW-98 Light Duty Buffing Pad (Not Shown)

SloanStone® EW-73000 Sink Cabinet and Basin Assembly

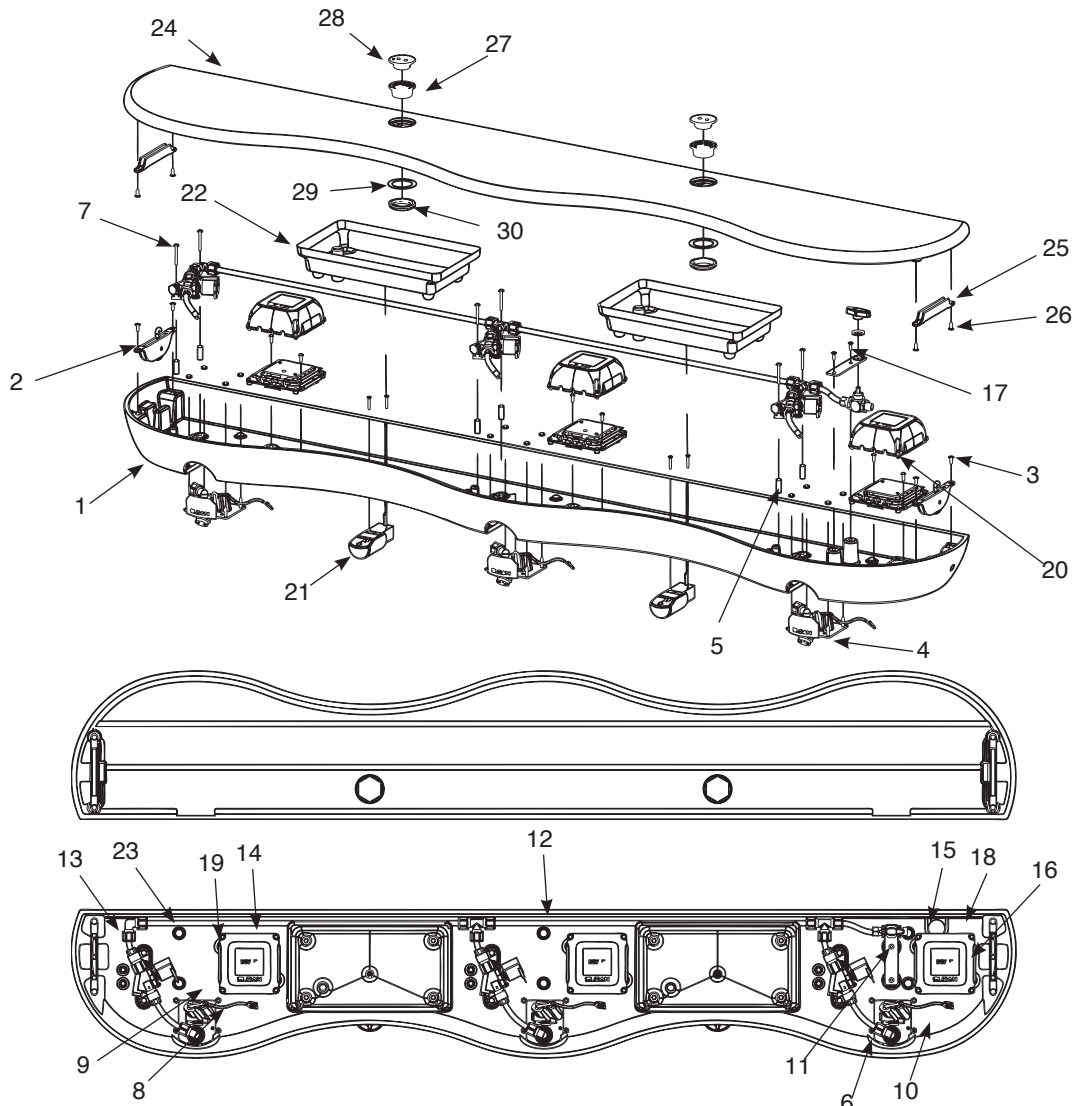

Item Part No. No.	Description
1.EW-56	Electronics Enclosure, 3 Station Machined
2.EW-41	Large Latch (2)
3.EW-27	Screw, Flat Head #10-24 x 1/2" Long (4)
4.EW-75-A	Sensor Plate Assembly (3)
5.EW-8	Spacer #8 x 1" Long (6)
6.EW-13	Mounting Clamp ETF-370-A Solenoid (6)
7.EW-9	Screw, Truss Head #8-32 x 1-1/2" Long (6)
8.ETF-61	Male Connector (6)
9. ETF-370-A	Solenoid Valve Assembly (3)
10.EW-89-00362	Tube 3/8" x 3-5/8" Long (3)
11.EW-89-00188	Tube 3/8" x 1-7/8" Long (3)
12.EW-19	Compression Tee Fitting 3/8" Tube (2)
13.EW-18	Compression Elbow Fitting 3/8" Tube
14.EW-89-02525	Tube 3/8" x 25-1/4" Long (2)
15.EW-89-00388	Tube 3/8" x 3-7/8" Long (1)
16.EW-5	Mounting Bracket for Shut-off Valve
17.EW-36	Screw, Pan Hd #8-32 x 7/16" Long (SEMS) (2)
18.EW-74	Panel Mount Ball Valve - 3/8" Compression Fitting
19.ETF-450-A	Splash Proof Junction Box Assembly (3)
20.EW-28	Screw, Round Head #8-32 x 1/2" Long (6)
21. † ESD-255-A	Manual Soap Pump Assembly (2)

Item Part No. No.	Description
22. † ESD-245-A	Soap Reservoir Assembly (2)
23. EW-37	Screw, Truss Head 1/4-20 x 1-1/2" Long (6) (Not Shown)
— EW-26	Tube Support 3/8" (7) (Not Shown)
— MIX-135-A	Thermostatic Mixing Valve (Below Deck) (Not Shown)
— EW-92-A	Wiring Harness 3 Station (Not Shown)
— ETF-233	Transformer (Not Shown)
— ETF-731	Vandal Proof Key, Standard and Junior (Not Shown)
— EW-97	Flexible Supply Hose, 3 Station (Not Shown)
— EW-96	T-Handle Hex Wrench 7/32" (Not Shown)
24. EW-58-X	Cover, Electronics Enclosure, 3 Station Machined
25. EW-42	Large Encased Receiver (2)
26. EW-27	Screw, Flat Head #10-24 x 1/2" Long (4)
27. ‡ ESD-242	Sleeve for Fill Cap (2)
28. ‡ ESD-241	Fill Cap for Soap Reservoir (2)
29. ‡ EW-11	Gasket for Fill Cap Sleeve (2)
30. ‡ ESD-243	Jam Nut for Fill Cap Sleeve (2)
— ‡ ESD-249	Fill Cap Spanner (Not Shown)

† Included on models with Soap Dispenser.
‡ Included on models with Fill Cap.

SloanStone® EW-73000 Sink Head Assembly

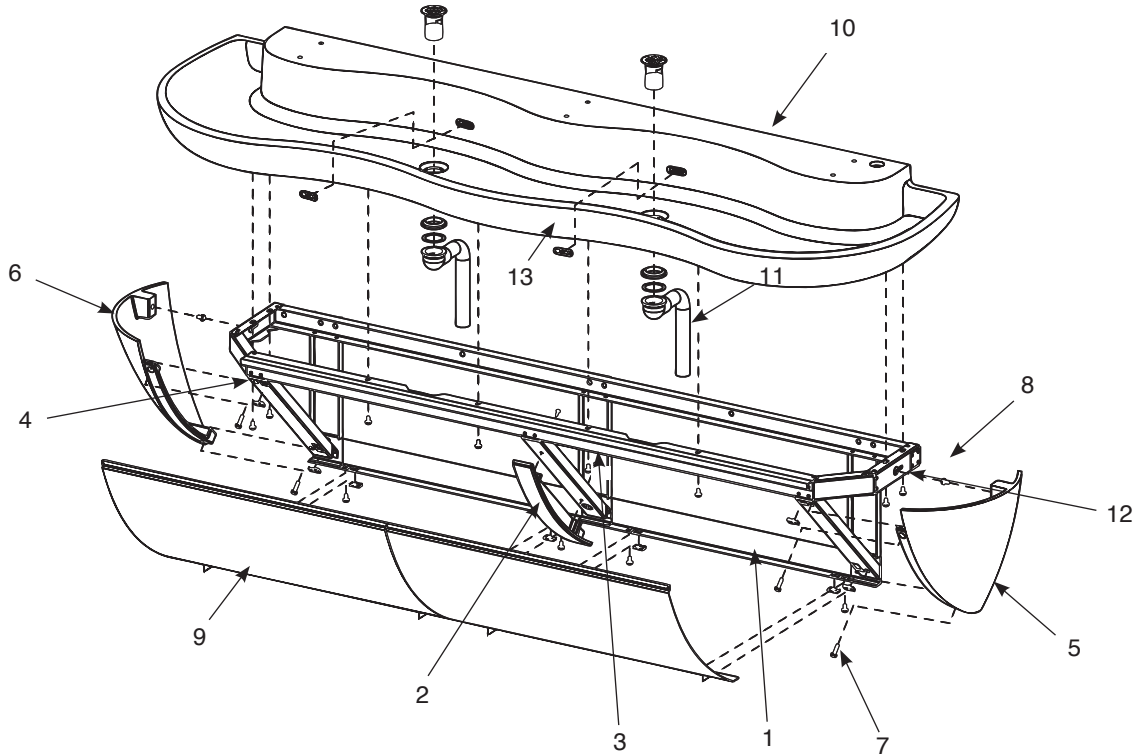

Item No.	Part No.	Description
1.	EW-30-A	Cabinet Weldment, 3 Station
2.	EW-50	Front Panel Support - Machined
3.	EW-36	Screw, Pan Head #8-32 x 7/16" Long (SEMS) (2)
4.	EW-99	U-type Nut, Standard 1/4-20 Thread (8)
5.	EW-60	End Cap Right - Machined
6.	EW-52	End Cap Left - Machined
7.	EW-16	Screw, Pan Head 1/4-20 x 1" Long (SEMS) (4)

Item No.	Part No.	Description
8.	EW-15	Screw, Pan Head 1/4-20 x 1/2" Long (SEMS) (2)
9.	EW-35	Front Panel, 3 Station (2)
10.	EW-54	Triple Station Lavatory Basin Assembly
11.	ETF-725-A	Grid Strainer Assembly (2)
12.	EW-15	Screw, Pan Head 1/4-20 x 1/2" Long (SEMS) (8)
13.	EW-61	Overflow Cover Plate (2)
—	EW-98	Light Duty Buffing Pad (Not Shown)

Troubleshooting Guide

1.No water flows when sensor is activated
Ensure that main power supply is turned "ON." Check receptacle, transformer, solenoid, leads and connections.

If Sensor LED does not blink:

- A. Control module circuit board is faulty; replace.
- B. Sensor is faulty; replace sensor module.

If Sensor LED blinks when user is sensed:

- A. Supply Stop(s) may be closed; open Supply Stop(s).
- B. Debris may be in Solenoid filter; remove, clean and reinstall.

2.Very low flow or slow dribble

- A. Supply Stop(s) may be closed; open Supply Stop(s).
- B. Debris is in solenoid, won't close properly; remove operator and clean. Reassemble in the same manner.
- C. Debris is in Solenoid filter; remove, clean and reinstall.
- D. Debris is in spray head; remove, clean and reinstall.

3.Continues to run (even after power to faucet has been disconnected)

- A. Solenoid valve is installed backwards; install correctly.
- B. Debris is in solenoid, won't close properly; remove operator and clean. Reassemble in the same manner.