

INSTALLATION INSTRUCTIONS FOR DOUBLE AND TRIPLE STATION SENSOR ACTIVATED SOLID SURFACE LAVATORY SYSTEMS



ELS-63000
ELS-72000
Double Station
Sensor Activated
Solid Surface
Lavatory System
(ELS-72275-30 Shown)



ELS-63000
ELS-73000
Triple Station
Sensor Activated
Solid Surface Lavatory System
(ELS-73275-30 Shown)

LIMITED WARRANTY

Unless otherwise noted, Sloan Valve Company warrants this product, manufactured and sold for commercial or industrial uses, to be free from defects in material and workmanship for a period of three (3) years (one (1) year for special finishes, SF faucets, PWT electronics and 30 days for PWT software) from date of first purchase. During this period, Sloan Valve Company will, at its option, repair, replace, or refund the purchase price of any product which fails to conform with this warranty under normal use and service. This shall be the sole and exclusive remedy under this warranty. Products must be returned to Sloan Valve Company, at customer's cost. No claims will be allowed for labor, transportation or other costs. This warranty extends only to persons or organizations who purchase Sloan Valve Company's products directly from Sloan Valve Company for purpose of resale. This warranty does not cover the life of the batteries.

THERE ARE NO WARRANTIES WHICH EXTEND BEYOND THE DESCRIPTION ON THE FACE HEREOF. IN NO EVENT IS SLOAN VALVE COMPANY RESPONSIBLE FOR ANY CONSEQUENTIAL DAMAGES OF ANY MEASURE WHATSOEVER.

ROUGH-IN (FAUCETS MAY VARY)

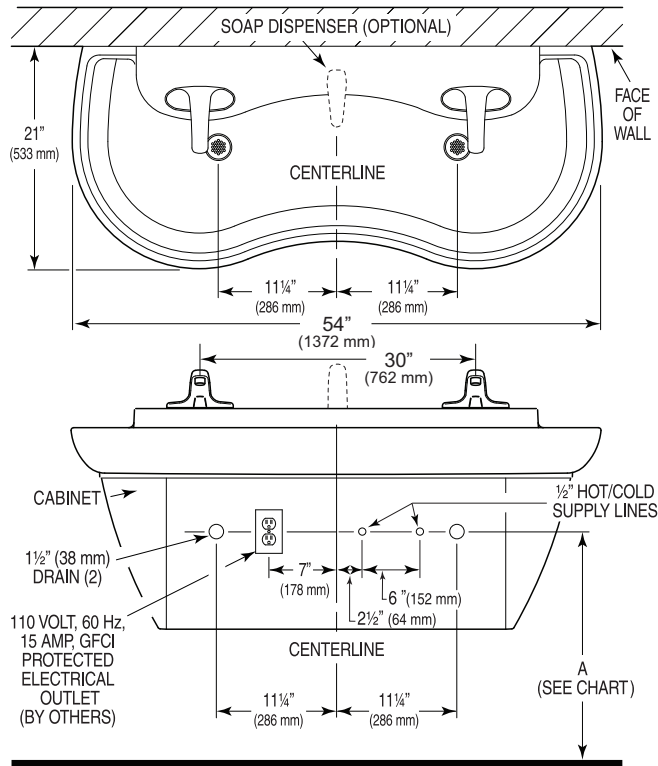

FOR MODELS:
ELS-62000
ELS-72000
 Double Station Lavatory System
Lavatory System Weight (Packaged):
 Approximately 88 Lbs (40 Kg)

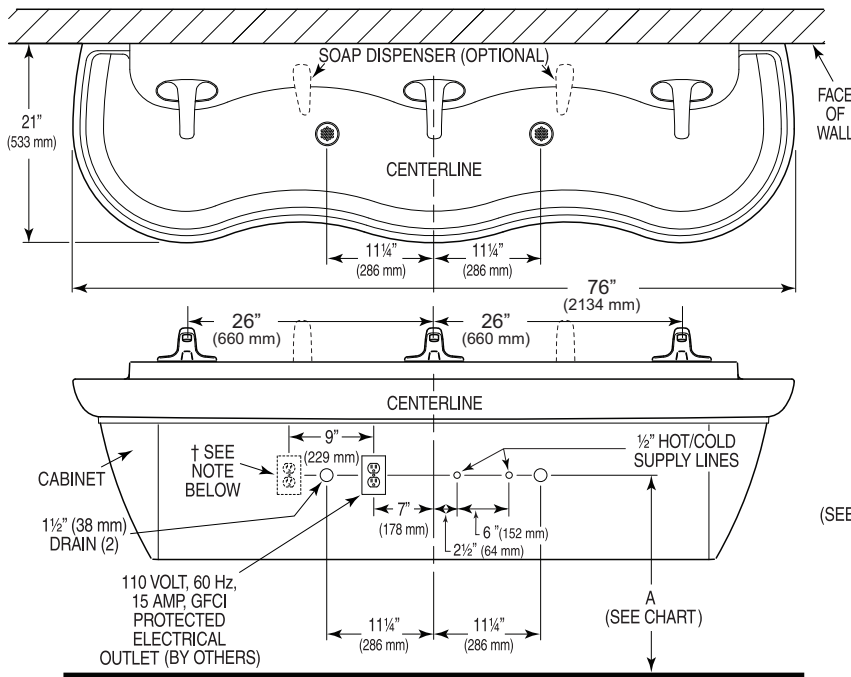
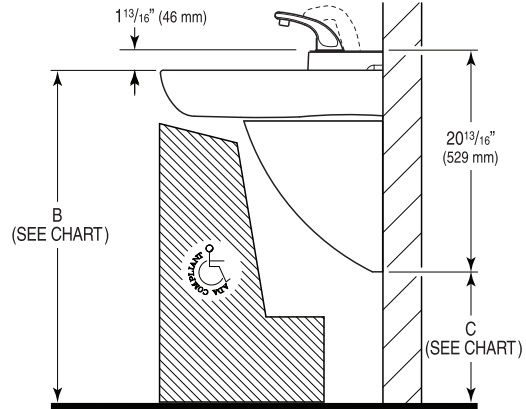

FOR MODELS:
ELS-63000
ELS-73000
 Triple Station Lavatory System
Lavatory System Weight (Packaged):
 Approximately 130 Lbs/59 Kg

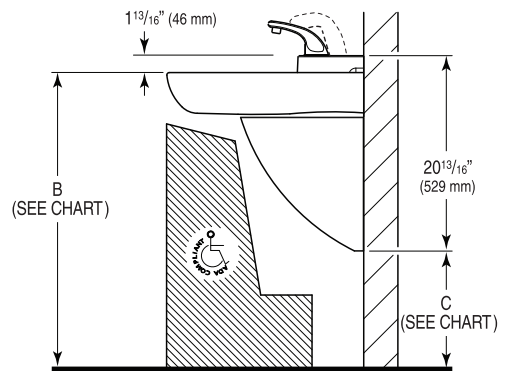

† An additional electrical outlet is required when installing two hardwire soap dispensers in conjunction with hardwire Faucets.

VARIABLE MOUNTING HEIGHT CHART

⦿	DIMENSION DESCRIPTION	T.A.S. AGES 4-10	T.A.S. AGES 11-15	A.D.A. STANDARD
A	ROUGH-IN	20-1/2" (521 mm)	22-1/2" (572 mm)	24" (610 mm)
B	RECOMMENDED RIM HEIGHT	29-7/8" (759 mm)	31-7/8" (810 mm)	33" (838 mm)
C	FLOOR CLEARANCE	10-7/8" (276 mm)	12-7/8" (327 mm)	14" (356 mm)
D	NOMINAL FRAME HEIGHT ‡	25-1/8" (638 mm)	27-1/8" (689 mm)	28-1/4" (718 mm)

‡ Refer to Step 3.

PRIOR TO INSTALLATION

Prior to installing the Sloan Optima ELS-60000/ELS-70000 Series Lavatory System, install the items listed below. Also, refer to the appropriate rough-in diagram on Page 2 and 3.

- Electrical receptacle(s) – 120 VAC, 2 amp service for plug-in faucets and soap dispensers. The ELS-73000-xx-MSD 3-station sink with hardwire soap dispensers in conjunction with hardwire faucets require TWO electrical outlets (see rough-in on Page 2), all others require ONE.
- Hot and cold water supply lines or tempered water supply line (If there is no tempered water supply, install thermostatic mixing valve between hot and cold water supply)
- Drain lines

IMPORTANT:

- **ADEQUATE STRUCTURAL SUPPORT IN OR BEHIND THE WALL IS REQUIRED. REFER TO THE APPROPRIATE ROUGH-IN DIAGRAM ON PAGE 2 FOR DRY WEIGHT OF SINK. STRUCTURAL SUPPORT MUST HAVE A MINIMUM PULLOUT RATING OF 1000 POUNDS (450 Kg) FOR EACH FASTENER.**
- **ALL PLUMBING SHOULD BE INSTALLED IN ACCORDANCE WITH APPLICABLE CODES AND REGULATIONS.**
- **BEFORE CONNECTING SUPPLY LINES TO SUPPLY STOPS, FLUSH ALL WATER LINES UNTIL WATER IS CLEAR.**

WHEN INSTALLING HARDWIRED FAUCETS AND SOAP DISPENSERS:

- **ALL ELECTRICAL WIRING SHOULD BE INSTALLED IN ACCORDANCE WITH NATIONAL/LOCAL CODES AND REGULATIONS.**
- **A 24 VAC STEP-DOWN TRANSFORMER MUST BE USED FOR HARDWIRE FAUCETS(S) AND 6 VAC PLUG-IN ADAPTER FOR SOAP DISPENSER(S).**
- **USE APPROPRIATE PRECAUTIONS WHILE CONNECTING TRANSFORMER TO 120 VAC POWER SOURCE.**
- **DO NOT PLUG TRANSFORMER INTO POWER SOURCE (RECEPTACLE) UNTIL ALL WIRING IS COMPLETED. PERMANENT DAMAGE TO THE TRANSFORMER AND CIRCUIT CONTROL MODULE WILL RESULT IF 24 VAC WIRES TOUCH EACH OTHER OR SHORT WHEN POWER SUPPLY IS ACTIVE.**

TOOLS REQUIRED FOR INSTALLATION

- Electric drill for drilling anchor holes.
- Standard sockets and open end wrench set for installing anchoring fasteners and connecting water lines.
- Open end wrench for connecting water lines.
- Pipe wrench for installing drain lines.
- Phillips and straight blade screwdrivers.

SINK LOCATION

Determine the appropriate wall location for the Lavatory System. Consider that hot and cold water supply lines, drain lines, and an electrical source (receptacle or wiring depending on type of transformer used when installing hardwire faucets and soap dispensers) will be required. Compare the physical dimensions of the Lavatory System to the space available for the installation. If wall is not load bearing, a carrier may be required behind the wall. Refer to the appropriate Rough-in diagram on Page 2 and 3 for Lavatory System dimensions.

Prior to Lavatory System installation, electric wiring (when installing hardwire faucets and soap dispensers), water supply and drain must be installed.

1 – INSTALL THERMOSTATIC MIXING VALVE

- A** If there is no tempered water supply, install Thermostatic Mixing Valve between hot and cold water supply.

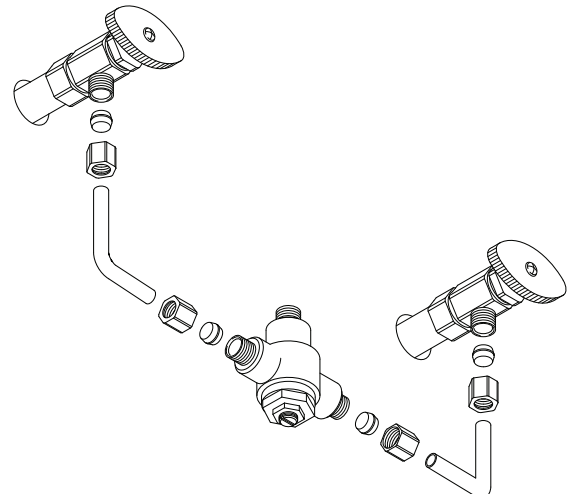

2 – MOUNTING WALL BRACKETS

Double Station

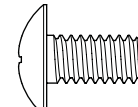
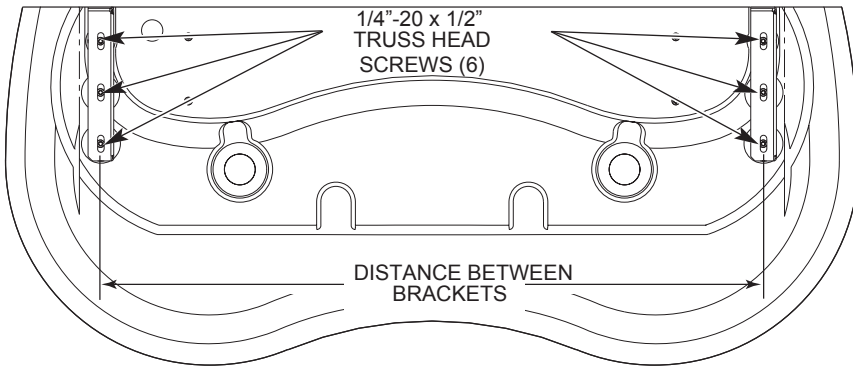

1/4"-20 x 1/2" Truss Head Screw
(Actual Size)

- A** Attach brackets to basin using 1/4"-20 x 1/2" truss head screws.
- B** Measure distance between brackets. Make sure the carrier (when needed) can accommodate the proper location for the brackets.

Triple Station

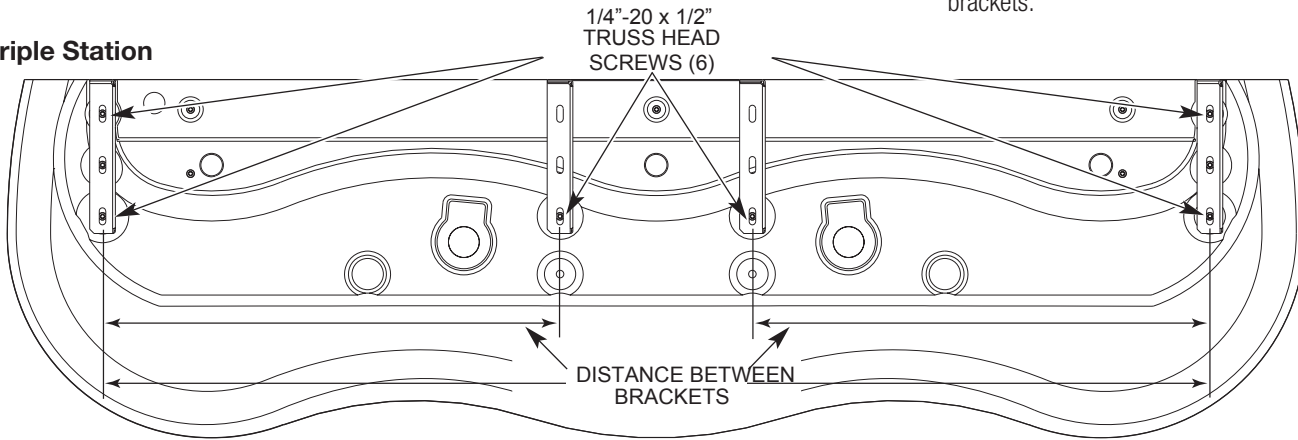

- C** Determine the appropriate location for the holes to secure the brackets to the wall. Use the following dimensions as a reference.
- D** Mount basin and brackets to wall using fasteners with waster that hold over 1000 lbf (pounds-force) withdrawal load each.

NOTE: IF DESIRED, DETACH BRACKETS FROM BASIN AND MOUNT BRACKETS TO WALL FIRST. THEN MOUNT BASIN TO BRACKETS USING 1/4"-20 X 1/2" TRUSS HEAD SCREWS. GRID STRAINER MAY BE INSTALLED PRIOR TO ATTACHING BASIN TO BRACKETS. REFER TO STEP 6.

Double Station

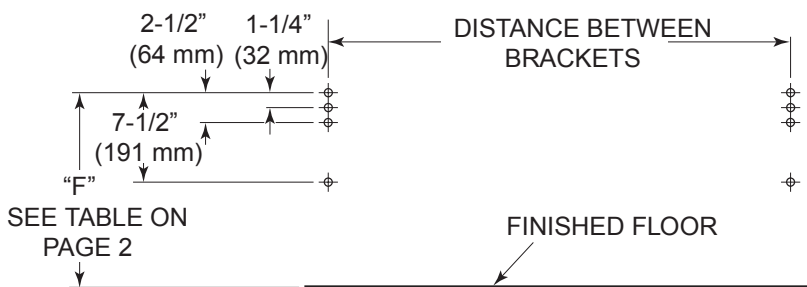

Triple Station

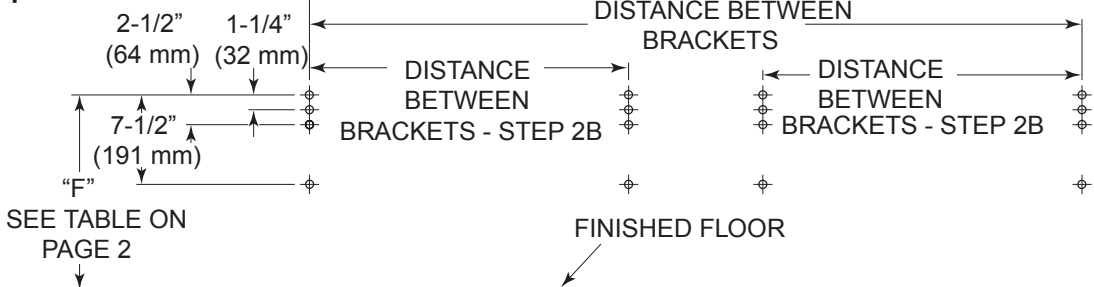

3 – REMOVE END CAPS FROM FRAME

A Loosen (do not remove) screws on inside of frame.

B Remove both End Caps by removing the two outer screws on each Cap. Slide Cap forward in slot and pull it out through enlarged hole in Frame.

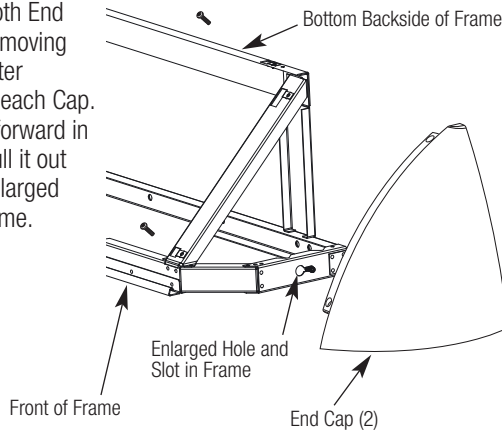

C For triple station sinks, remove the Front Panel Support.

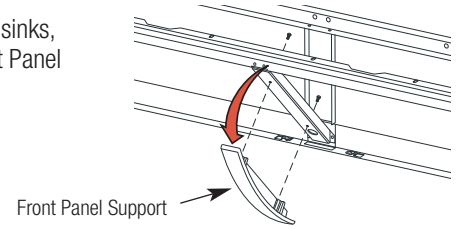

4 – MOUNT FRAME TO WALL (FOR ELS-70000 SERIES)

A If desired, apply adhesive to back surfaces of Frame.

B Mount Frame to wall using 3/8" fasteners with 1000 lb min pull out strength in the following locations:

1. Each hole in the extreme outer corners of top support
2. One of either of the two holes in the top position of each upright
3. The lower hole location in each upright

Fasteners may be optionally applied to any of the remaining mounting hole locations. Level Frame in both directions before tightening fasteners securely.

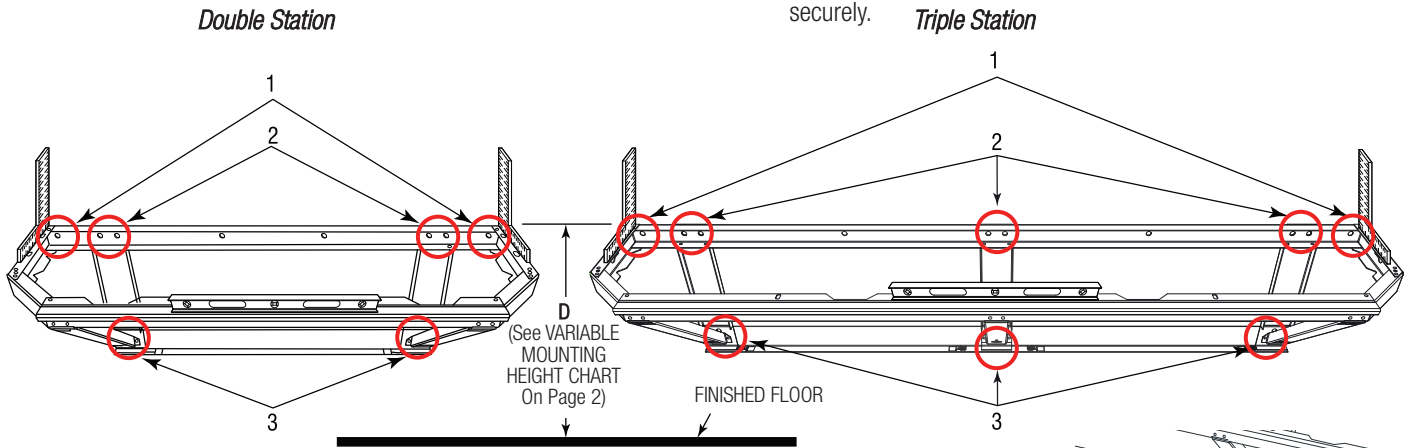

C For triple station sinks, reinstall the Front Panel Support.

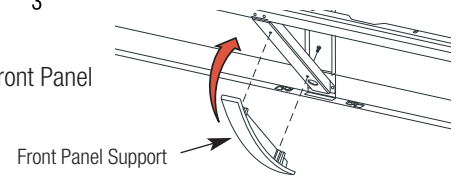

D For installations including the optional SJS-1650 Soap Dispenser, refer to Soap Dispenser Installation Instructions.

5 – MOUNT BASIN TO FRAME (FOR ELS-70000 SERIES)

Note: If desired, Grid Strainers, Faucets and Soap Dispensers may be installed prior to mounting Basin to the Frame. Refer to Steps 5 and 6.

- A** Mount Basin to Frame using 1/4"-20 x 1/2" SEMS fasteners.

Double Station

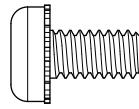
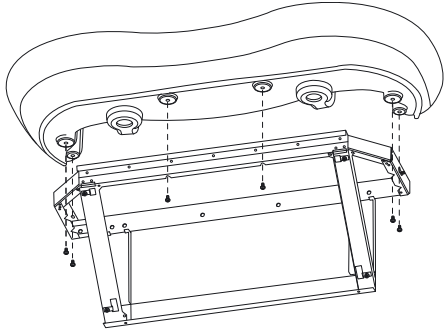

1/4"-20 x 1/2" Pan Head Screw (SEMS)
(Actual Size)

- B** If desired, apply caulk between Basin and wall.

Triple Station

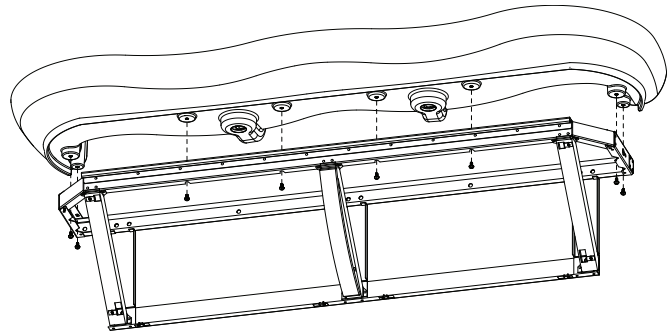

6 – INSTALL GRID STRAINERS AND CONNECT DRAIN LINE

- A** Install Grid Strainers.
- B** Plumb drain outlets to wall.

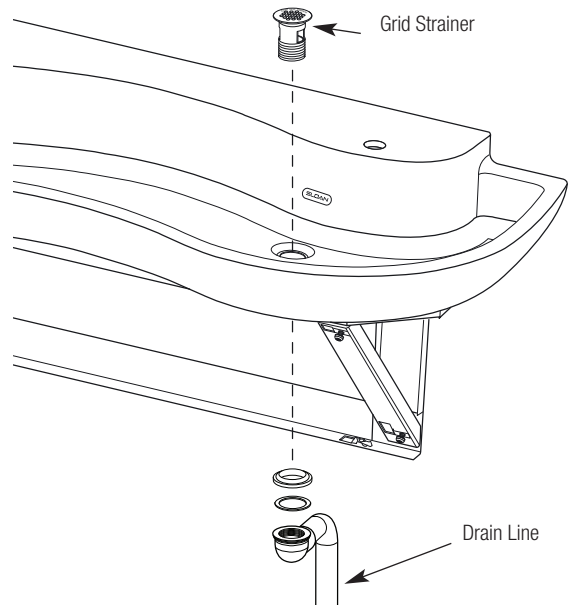

7 – INSTALL FAUCETS AND SOAP DISPENSERS

Install Faucets and Soap Dispensers as instructed in the installation instructions furnished with the Faucets and Soap Dispensers. Also see Step 7 for Transformer hookup.

SOAP DISPENSER OPTIONS



SJS-1650

ESD-350

FAUCET OPTIONS



ETF-80/EBF-85

SF-2100/SF-2150

SF-2200/SF-2250

SF-2300/SF-2350

MORE FAUCET OPTIONS



EAF-100/150

EAF-275

EAF-200/250

EAF-225

ETF-610/EBF-615



EFX-3 SERIES

EFX-6 SERIES



ETF-600/EBF-650

EFX-2 SERIES

EBF-187

8 – CONNECT FAUCET POWER CABLES TO TRANSFORMER AND PLUG TRANSFORMER INTO RECEPTACLE

- A** Connect one Power Cable from each Control Module to a Twist On Terminal. Connect second Power Cable from each Control Module to a second Twist On Terminal.

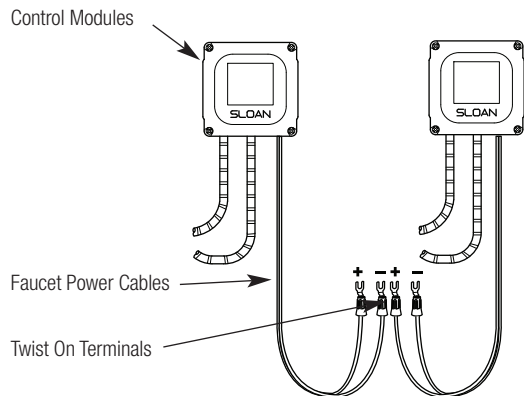

- B** Connect terminals to transformer.

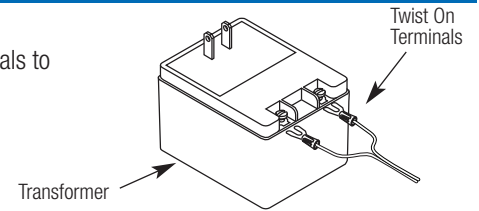

- C** Plug Transformer into outlet.

9 – CONNECT SUPPLY LINE TO THERMOSTATIC MIXING VALVE

- A** Install water Supply Line.

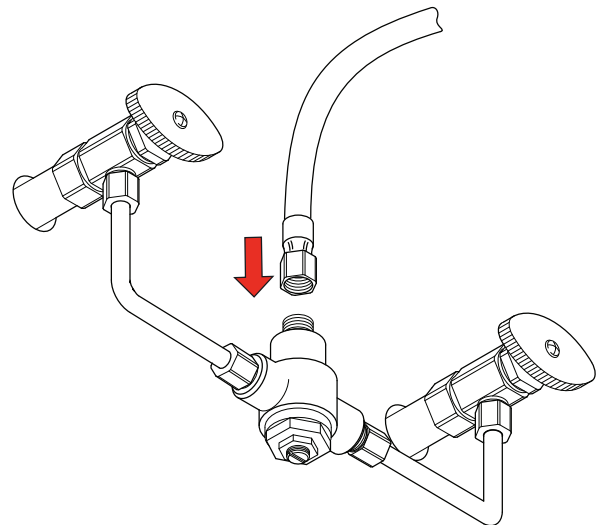

10 – TURN ON WATER SUPPLY, CHECK FOR WATER LEAKS AND INSTALL END CAPS

- A** Turn on water supply.
B Check all plumbing for water leaks.

- C** Replace End Caps. Insert the screw located on the inside of the Cap into the enlarged hole of the Frame. Then slide the Cap into place. Loosely install the two front screws. Slide End Cap UP to eliminate any gap between the End Cap and Basin. Tighten the inside screw securely. Lastly, tighten the two front screws securely. Follow the same procedure for the second End Cap.

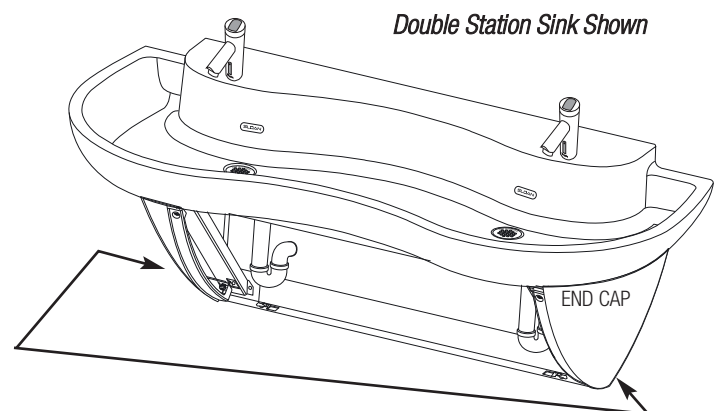

11 – INSTALL FRONT PANEL(S) – FOR ELS-7000 SERIES ONLY

- A** Replace Front Panel by hanging top lip of Panel into track of Trim Rail under Basin. Swing panel into position and affix with 2 Fasteners. For triple station sinks, repeat this procedure for second panel.

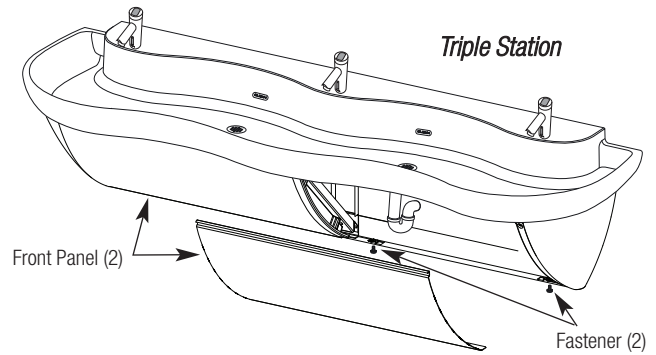
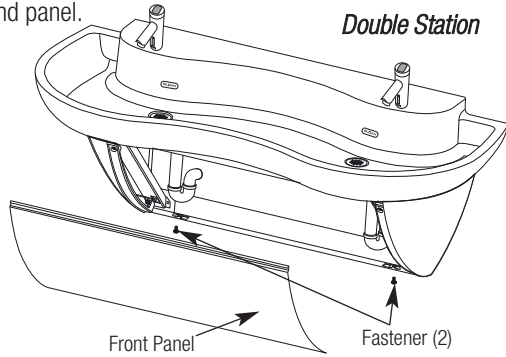

12 – INSTALL COVER CABINET – FOR ELS-6000 SERIES ONLY

NOTE: ENSURE THAT THERE ARE NO GAPS BETWEEN THE BASIN AND CABINET, AND THE CABINET AND WALL.

- A** Replace cover and screws and tighten firmly in place with t-handled wrench.

- B** Install plastic cabinet by fastening it to the wall via screws through cabinet's mounting eyelets. Double-station (6) fasteners and triple-station (8) fasteners. Prior to fastening the triple-station cabinet to the wall, bring the cabinet to the basin and press the front of the cabinet to the basin ensuring that the velcro straps, pre-applied to the basin and cabinet, meet and attach firmly. Allow the cabinet to hang from the basin, while fastening the cabinet to the wall.

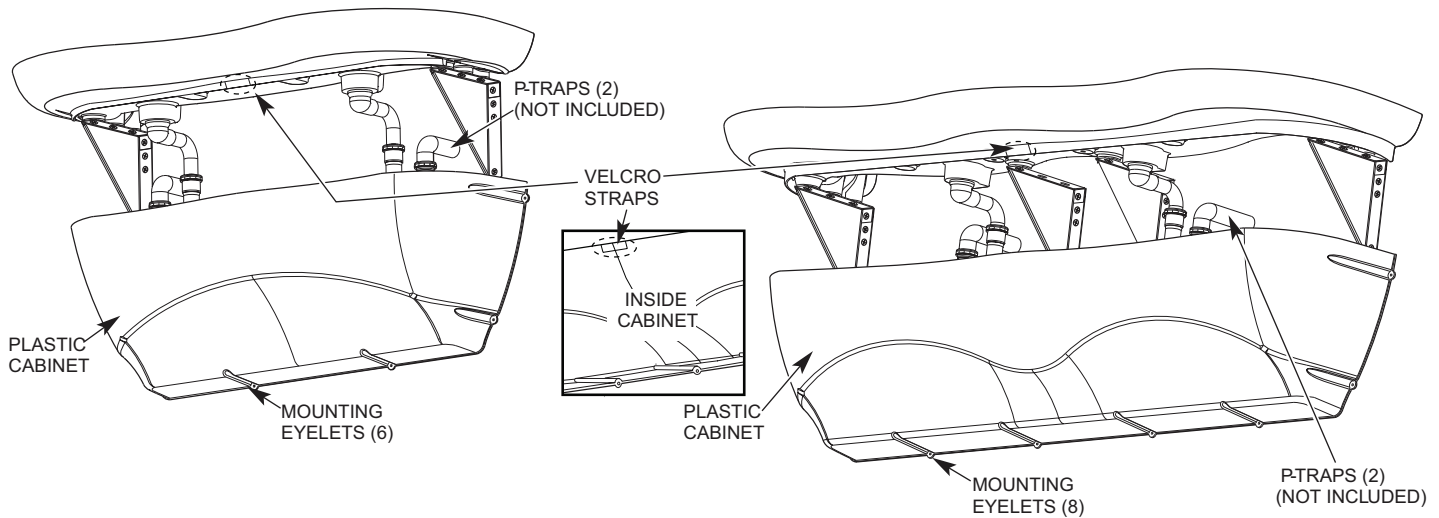

OPTIONAL – SOAP DISPENSER PUMP MOUNTING INSTRUCTIONS

A **FOR ELS-70000 SERIES ONLY** – Install Soap Dispenser Pump (SJS-1650 for battery powered applications and SJS-1750 for hardwire applications) at the location(s) shown. Mount Soap Dispenser as instructed in the Installation Instructions furnished with the Soap Dispenser using spacers and extended length screws provided.

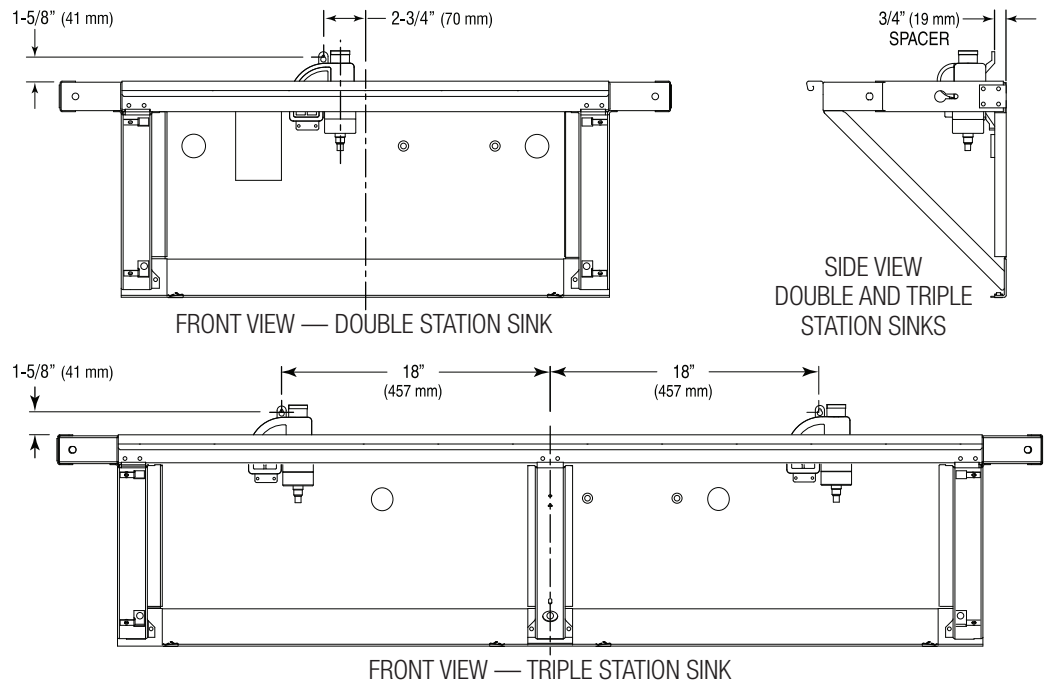

SLOANSTONE® CARE AND MAINTENANCE

SloanStone® surfaces may be easily cleaned using a conventional cleaning agent such as an ammonia based liquid cleaner (glass cleaner). Cover faucet(s) and, if applicable, soap dispenser(s) to protect the finish. **DO NOT USE** the same cloth that was used to wipe down SloanStone surface as the faucet(s) and, if applicable, soap dispenser(s).

Dry stains on a matte finish can be removed with a 3M Scotch-Brite scouring pad or a mild abrasive cleaner.

Burns or scorches can be removed by sanding with the Light Duty Buffing Pad (included with SloanStone sinks). Follow sanding with the General Purpose Buffing Pad (included with SloanStone sinks) to match finish of sanding area to surrounding area. A final buffing may be required on polished surfaces. Accidental nicks or chips can be repaired with a special patch kit available in all SloanStone colors, contact Sloan 1-888-SLOAN-14 (1-888-756-2614) or your Sloan Representative, if needed.

Avoid exposing SloanStone surfaces to strong chemicals such as acetones, paint removers/thinners and sulfuric acid, or hydrochloric chemical cleaners. Exposure to strong chemicals may result in permanent damage to SloanStone surfaces.

REFER TO FAUCET OR SOAP DISPENSER INSTALLATION INSTRUCTIONS SHEET FOR TROUBLESHOOTING AND OPERATION INSTRUCTIONS

PARTS LIST

ELS-62000 Double Station Cabinet and Basin Assemblies

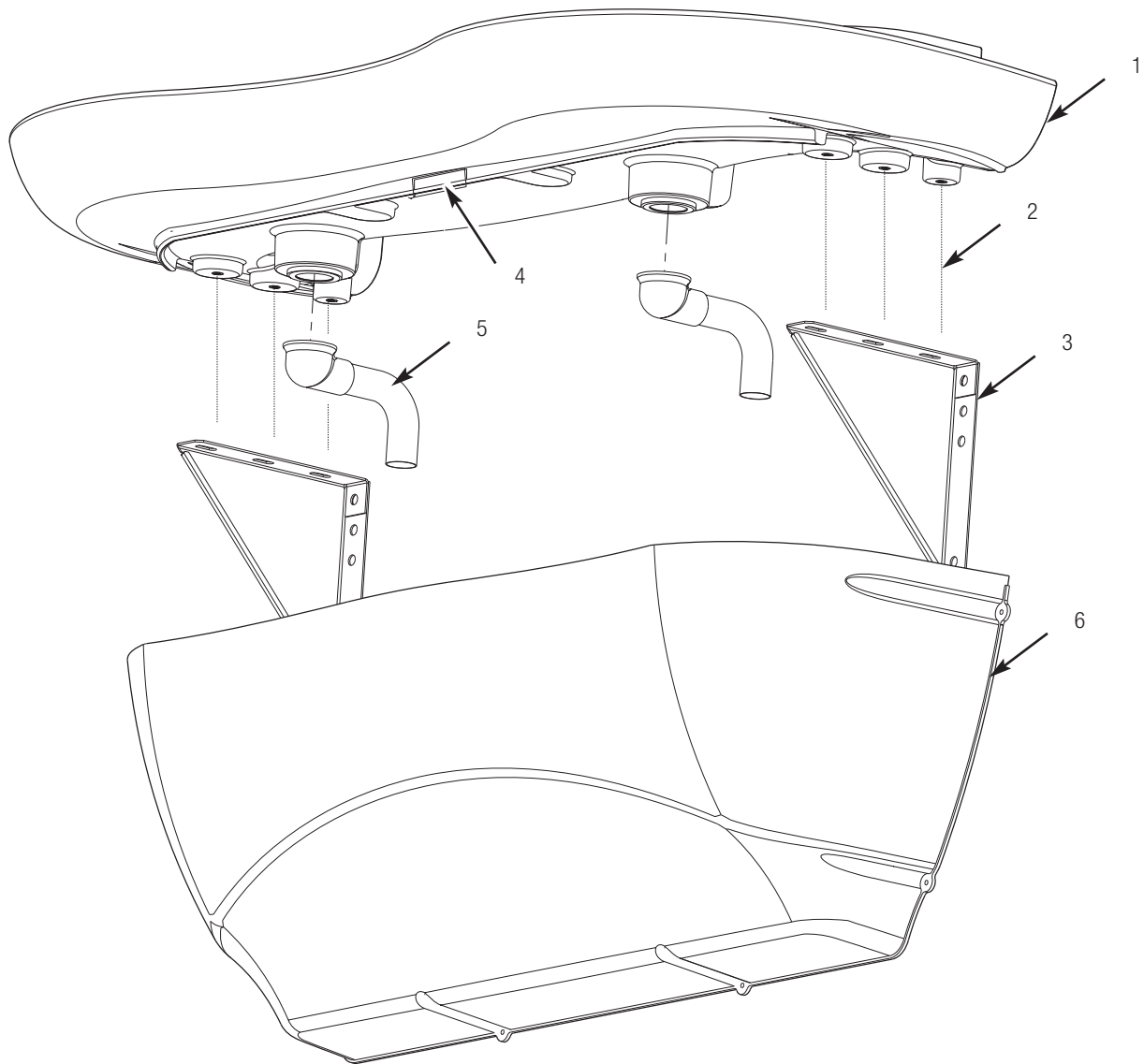

Item No.	Part No.	Description
1	SEE TABLE	Double Station Lavatory Basin Assembly
2	ELC-41	Screw, Machine Truss Head 1/4-20 (6)
3	EW-122	Mounting Bracket (4)

Item No.	Part No.	Description
4	EW-127	Velcro Strip (Hook)
5	ETF-725-A	Grid Strainer Assembly (2)
6	EW-105	Plastic Cabinet for Double Station Lavatory
-	EW-98	Light Duty Buffing Pad (Not Shown)
-	EW-108	General Duty Buffing Pad (Not Shown)

ITEM NO. 1 — Double Station Lavatory Basin Hole Patterns

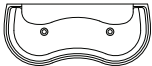
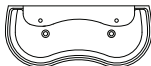
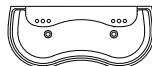
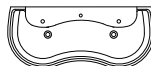
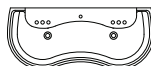
Hole Pattern	—	A	B	C	D
Part No.	ELS-9-A-XXX	ELS-9-A-XXX-A	ELS-12-A-XXX-B	ELS-12-A-XXX-C	ELS-12-A-XXX-D
Basin Hole Pattern					

PARTS LIST

ELS-63000 Triple Station Cabinet and Basin Assemblies

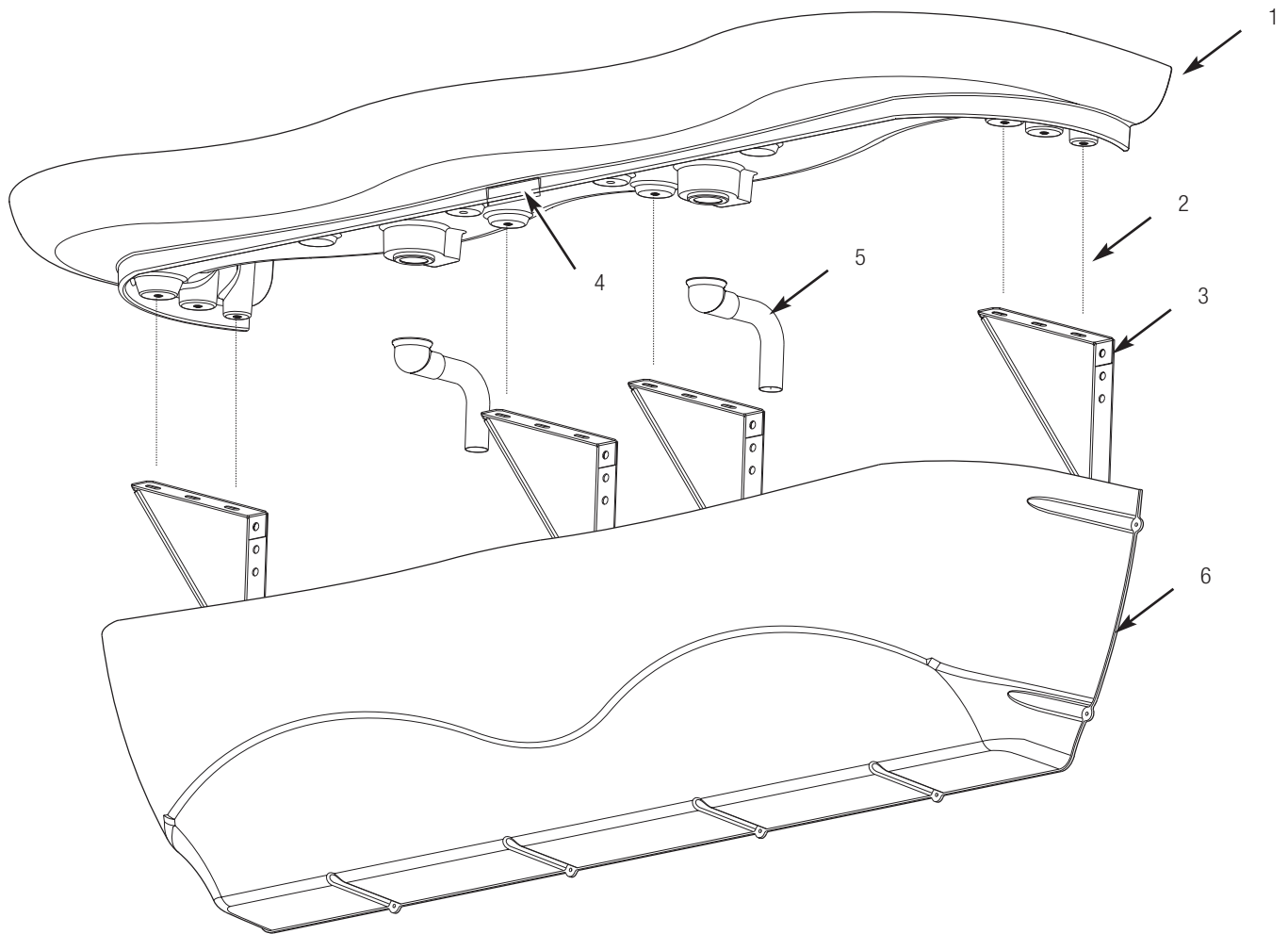

Item No.	Part No.	Description	Item No.	Part No.	Description
1	SEE TABLE	Triple Station Lavatory Basin Assembly	4	EW-127	Velcro Strip (Hook)
2	ELC-41	Screw, Machine Truss Head 1/4-20 (6)	5	ETF-725-A	Grid Strainer Assembly (2)
3	EW-122	Mounting Bracket (4)	6	EW-123	Plastic Cabinet for Triple Station Lavatory
			-	EW-98	Light Duty Buffing Pad (Not Shown)
			-	EW-108	General Duty Buffing Pad (Not Shown)

ITEM NO. 1 – Triple Station Lavatory Basin Hole Patterns

Hole Pattern	-	A	B	C	D
Part No.	ELS-11-A-XXX	ELS-11-A-XXX-A	ELS-11-A-XXX-B	ELS-11-A-XXX-C	ELS-11-A-XXX-D
Basin Hole Pattern					

PARTS LIST

ELS-72000 Double Station Cabinet and Basin Assemblies

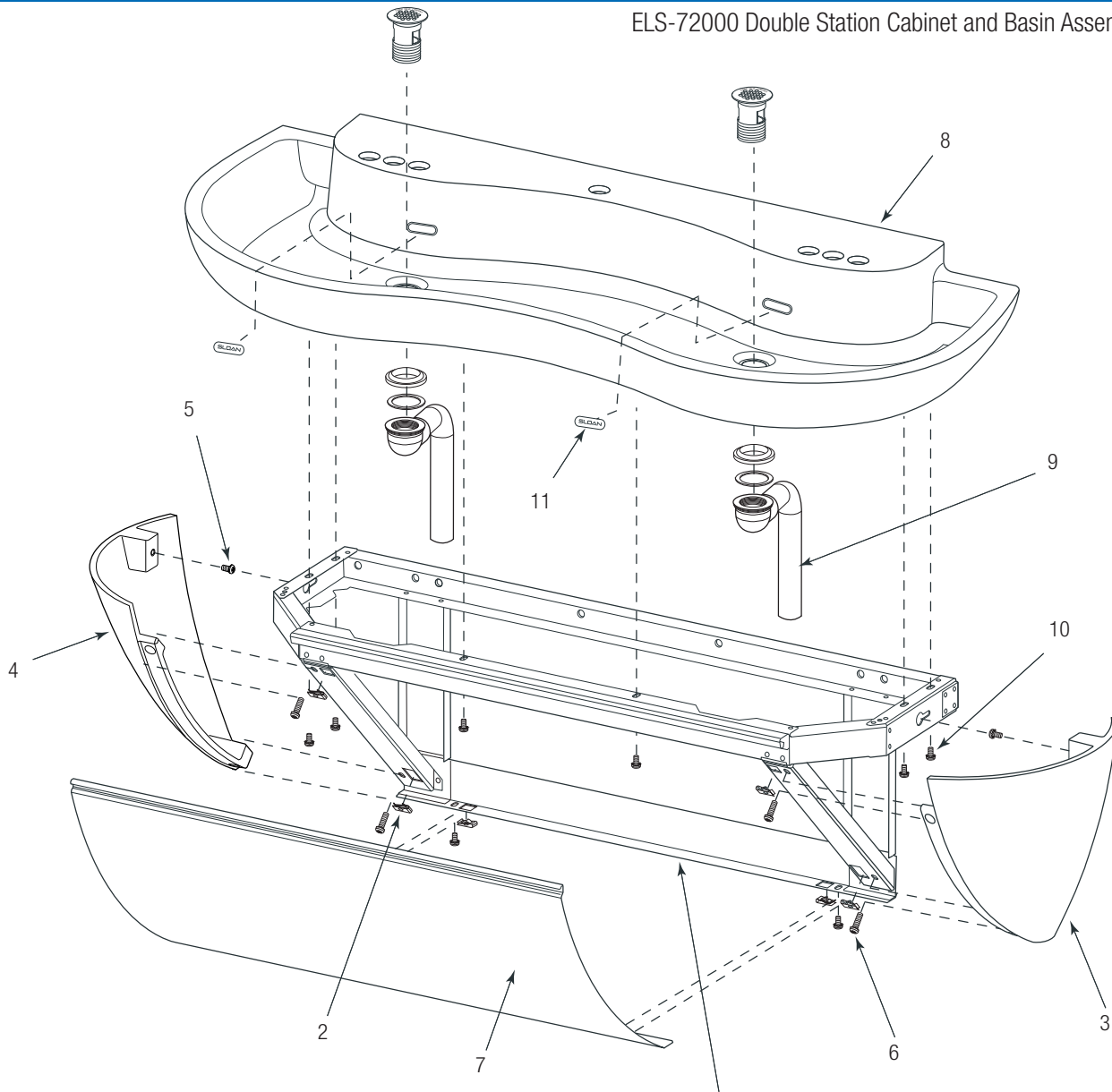

Item No.	Part No.	Description
1	EW-20-A	Cabinet Weldment, 2 Station
2	EW-99	U-Type Nut Standard 1/4-20 Thread (6)
3	EW-60	End Cap Right - Machined
4	EW-52	End Cap Left - Machined
5	EW-15	Screw, Pan Head 1/4-20 x 1/2" Long (SEMS) (2)
6	EW-16	Screw, Pan Head 1/4-20 x 1" Long (SEMS) (4)
7	EW-25	Front Panel, 2 Station

Item No.	Part No.	Description
8	SEE TABLE	Double Station Lavatory Basin Assembly
9	ETF-725-A	Grid Strainer Assembly (2)
10	EW-15	Screw, Pan Head 1/4-20 x 1/2" Long (SEMS) (6)
11	EW-61	Overflow Cover Plate (2)
-	EW-98	Light Duty Buffing Pad (Not Shown)
-	EW-108	General Duty Buffing Pad (Not Shown)

ITEM NO. 8 — Double Station Lavatory Basin Hole Patterns

Hole Pattern	—	A	B	C	D
Part No.	ELS-9-A-XXX	ELS-9-A-XXX-A	ELS-12-A-XXX-B	ELS-12-A-XXX-C	ELS-12-A-XXX-D



PARTS LIST

ELS-73000 Triple Station Cabinet and Basin Assemblies

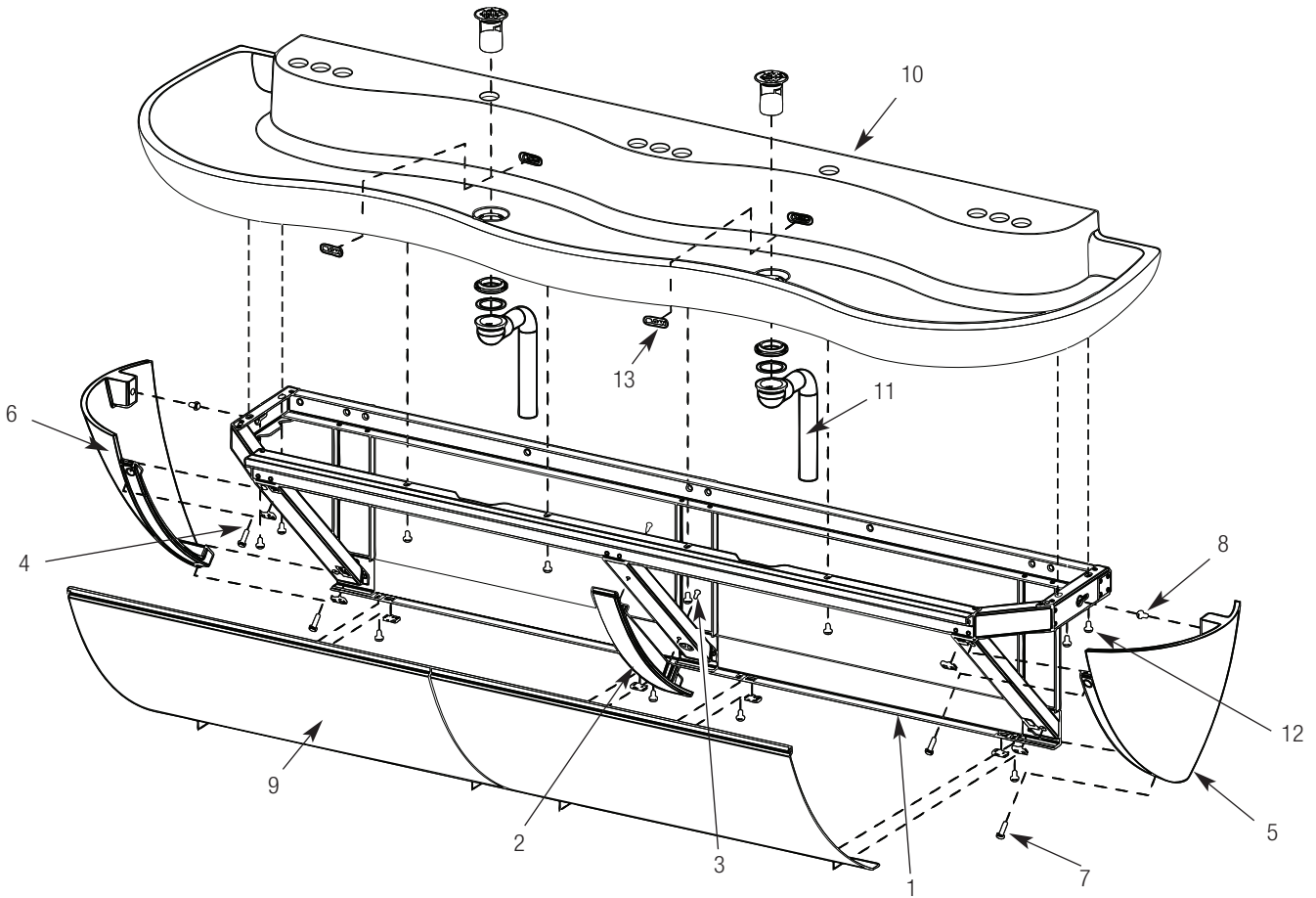

Item No.	Part No.	Description	Item No.	Part No.	Description
1	EW-149	Cabinet Weldment, 3 Station	8	EW-15	Screw, Pan Head 1/4-20 x 1/2" Long (SEMS) (2)
2	EW-50	Front Panel Support - Machined	9	EW-155	Front Panel, 3 Station (2)
3	EW-36	Screw, Pan Head #8-32 x 7/16" Long (SEMS) (2)	10	SEE TABLE	Triple Station Lavatory Basin Assembly
4	EW-99	U-type Nut, Standard 1/4-20 Thread (8)	11	ETF-725-A	Grid Strainer Assembly (2)
5	EW-60	End Cap Right - Machined	12	EW-15	Screw, Pan Head 1/4-20 x 1/2" Long (SEMS) (8)
6	EW-52	End Cap Left - Machined	13	EW-61	Overflow Cover Plate (2)
7	EW-16	Screw, Pan Head 1/4-20 x 1" Long (SEMS) (4)	-	EW-98	Light Duty Buffing Pad (Not Shown)
			-	EW-108	General Duty Buffing Pad (Not Shown)

ITEM NO. 10 – Triple Station Lavatory Basin Hole Patterns

Hole Pattern	-	A	B	C	D
Part No.	ELS-11-A-XXX	ELS-11-A-XXX-A	ELS-11-A-XXX-B	ELS-11-A-XXX-C	ELS-11-A-XXX-D



**When assistance is required, please contact Sloan Tech Support at:
1-888-SLOAN-14 (1-888-756-2614)**

The information contained in this document is subject to change without notice.