

Stainless Steel EHS-1000 Sink

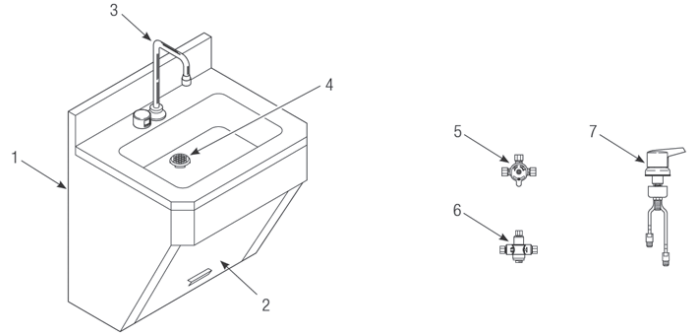

Item No.	Part No.	Description
1.	—	Sink Cabinet
2.	—	Access Panel
3.	—	Lavatory or Gooseneck Faucet Assembly†
4.	—	Grid Strainer Assembly
	—	Drain/P-Trap Assembly (not shown)
	—	Deluxe Triple Station Scrub Sink

Item No.	Description
MIX-60-A	Below Deck Mechanical Mixing Valve (Optional/BDM Variation)
MIX-135-A	Below Deck Thermostatic Mixing Valve (Optional/BDT Variation)
MIX-110-AA	Optimix® Deck Mounted Thermostatic Mixing Valve (Optional/ADM)
ETF-1009-A	Solenoid Valve Repair kit

Stainless Steel EHS-1000 Sink

TROUBLESHOOTING GUIDE

For Models:

EHS-1080 Hand Washing Sink with ETF-80 Faucet
EHS-1600 Hand Washing Sink with ETF-600 Faucet
EHS-1660 Hand Washing Sink with ETF-660 Faucet

Note: Remove Cover from Control Module to check diagnostic lights.

1. PROBLEM: No water is delivered when Faucet is activated.

INDICATOR: If no LED lights illuminate:

CAUSE: No electricity is being supplied to Faucet.

SOLUTION: Ensure that the main power is turned "ON." Check all Transformer, Sensor, Solenoid and Cable Connections. Make sure that Transformer is supplying 24 VAC (Volts AC). If no voltage is detected, replace Transformer.

CAUSE: There is an electrical system malfunction.

SOLUTION: Reset electrical system. Unplug Sensor Connection. Disconnect power to circuit for ten (10) seconds. Reconnect.

INDICATOR: If the GREEN LED does NOT illuminate when power is reconnected:

CAUSE: There is an electrical system malfunction.

SOLUTION: Reset electrical system. Unplug Sensor Connection. Disconnect power to circuit for ten (10) seconds. Reconnect.

CAUSE: The Control Module circuit is "dead."

SOLUTION: Replace ETF-450-A Control Module.

INDICATOR: If GREEN LED illuminates AND changes to RED when hands are in the Sensor's detection zone AND the RED Solenoid LED illuminates:

CAUSE: Water supply stop(s) may be partially closed.

SOLUTION: Open supply stop(s) completely.

CAUSE: Debris is clogging Solenoid Filter.

SOLUTION: Shut off water supply. Remove, clean and reinstall Solenoid Filter.

INDICATOR: If GREEN LED illuminates AND changes to RED when hands are placed in the Sensor's detection zone AND the RED Solenoid LED flickers with a vibrating/clicking noise heard inside the module:

CAUSE: There is a direct short in the Solenoid or Solenoid Cable.

SOLUTION: Replace with [ETF-370-A](#) Solenoid.

INDICATOR: If GREEN/RED LED illuminates AND changes to RED when hands are NOT located in the Sensor's detection zone BUT the RED Solenoid LED (in upper left corner of circuit) does NOT illuminate:

CAUSE: Sensor range is set too long and is detecting the sink.

SOLUTION: Reduce Sensor detection range.

INDICATOR: If GREEN LED illuminates BUT does NOT change to RED when hands are placed in the Sensor's detection zone:

CAUSE: Sensor range is set too short.

SOLUTION: Increase Sensor detection range.

EHS-1700 Hand Washing Sink with ETF-700 Faucet
EHS-1770 Hand Washing Sink with ETF-770 Faucet

2. PROBLEM: Sensing Range is too short.

CAUSE: Extended Range Sensitivity is required.

SOLUTION: Dip Switch number 4 should be in the "DOWN" (Extended Range Sensitivity) position. Increase range by adjusting Range Potentiometer clockwise (yellow phillips screw in blue base).

CAUSE: Faucet has Surgical Bend Gooseneck Spout.

SOLUTION: For Long Range use (recommended for Surgical Bend Gooseneck Spout Faucet models), remove Range Jumper from upper right hand corner of Circuit Board. Adjust Range Potentiometer.

3. PROBLEM: Faucet activates by itself (false triggers).

CAUSE: Sensor range is set too long.

SOLUTION: Decrease range by adjusting Range Potentiometer counterclockwise. If necessary, flip Dip Switch number 4 to the "UP" (Reduced Range Sensitivity) position. Check surroundings for factors that contribute to Sensor range detection problems (bright lights, highly reflective surfaces, sunlight, etc.).

4. PROBLEM: Faucet delivers very low flow or just a dribble.

CAUSE: Water supply stop(s) may be partially closed.

SOLUTION: Open supply stop(s) completely.

CAUSE: Debris is clogging Solenoid Filter.

SOLUTION: Shut off water. Remove, clean, and reinstall Solenoid Filter.

CAUSE: Solenoid is worn or faulty.

SOLUTION: Rebuild with ETF-1009-A Solenoid Repair Kit or replace ETF-370-A Solenoid.

CAUSE: Debris is clogging Faucet Aerator or Spray Head.

SOLUTION: Shut off water. Remove Aerator or Spray Head (use Key if required). Clean and reinstall Aerator or Spray Head.

5. PROBLEM: Faucet does not stop delivering water or continues to drip after user is no longer detected (even after power to the Module has been disconnected).

CAUSE: Solenoid Valve is installed backward.

SOLUTION: Disconnect Solenoid. Reconnect Solenoid with water flow toward the Faucet (see arrow on Solenoid).

CAUSE: Debris is clogging Solenoid.

SOLUTION: Remove and clean Solenoid Operator. If necessary, rebuild with ETF-1009-A Repair Kit.

CAUSE: Seat in Solenoid Valve body is damaged or pitted.

SOLUTION: Replace with [ETF-370-A](#) Solenoid.

Stainless Steel EHS-1000 Sink

TROUBLESHOOTING GUIDE

For Model:

EHS-1750 Hand Washing Sink with EBF-750 Faucet

Note: Remove Cover from Control Module to check diagnostic lights.

1. PROBLEM: Sensor LED does not function (indicator light on sensor window in faucet spout does not flash during initial 10 minute set-up mode).

CAUSE: There is no visible indicator light. Normal operation.

SOLUTION: This is a normal operating feature of the faucet.

2. PROBLEM: Faucet does not deliver any water when Sensor is activated.

INDICATOR: Solenoid valve produces audible "CLICK."

CAUSE: Water supply stop(s) closed.

SOLUTION: Open supply stop(s) completely.

INDICATOR: Solenoid valve DOES NOT produce an audible "CLICK."

CAUSE: Solenoid Lead is not properly connected to the Control Module.

SOLUTION: Disconnect and reconnect Solenoid Lead to Control Module.

CAUSE: No battery or Transformer power is being supplied to Sensor.

SOLUTION: Ensure that the batteries are installed properly. Check that the orientation of each battery matches the positive (+) and negative (—) symbols shown at bottom of battery compartment. Reinsert Batteries into Control Module. Transformer (optional) is unplugged or wall receptacle has no power.

CAUSE: Sensor Cable is not properly connected to the Control Module.

SOLUTION: Disconnect and reconnect Sensor Cable to Control Module.

CAUSE: Sensor range is set at minimum distance.

SOLUTION: Increase Sensor range.

CAUSE: Control Module assembly is defective.

SOLUTION: Replace Control Module assembly.

3. PROBLEM: Faucet delivers only a slow flow or dribble when Sensor is activated.

CAUSE: Water supply stop(s) partially closed.

SOLUTION: Open supply stop(s) completely.

CAUSE: Solenoid Filter is clogged.

SOLUTION: Remove, clean and reinstall Filter.

CAUSE: Aerator or Spray Head is clogged.

SOLUTION: Remove, clean and reinstall Aerator or Spray Head.

4. PROBLEM: Faucet does not stop delivering water or continues to drip after user is no longer detected (automatic shut-off fails even when batteries are removed).

CAUSE: Solenoid Valve has been connected backwards.

SOLUTION: Disconnect Solenoid Valve compression fittings at both the inlet and outlet positions. The water should flow from inlet through the Solenoid Valve to the outlet according to the direction of the arrow shown on the side of the Solenoid Valve. Reconnect the compression fittings in the correct orientation.

CAUSE: Solenoid Valve is dirty.

SOLUTION: Backflush by reversing water flow (opposite to the direction shown by the arrow on the side of the Solenoid Valve) through the Solenoid Valve. Reconnect the compression fittings in the correct orientation. Activate faucet.

5. PROBLEM: The water temperature is too hot or too cold on a faucet connected to hot and cold supply lines with Bak-Chek® Tee.

CAUSE: Supply stops are not adjusted properly.

SOLUTION: Adjust supply stops.

NOTE: For some systems, a Thermostatic Mixing Valve may be required.

6. PROBLEM: Red LED turns on in the control module (below deck).

CAUSE: One (or more) of the batteries is "dead."

SOLUTION: To ensure proper operation, insert four (4) new AA-size Alkaline batteries. Check that the orientation of each battery matches the positive (+) and negative (—) symbols shown on the bottom of the battery compartment. Reinsert Batteries into the Control Module.

NOTE: Upon start-up mode (1st ten minutes) the control module circuitry tests the batteries and the Red LED turns on if the battery voltage is low. No Red LED light indicates normal battery voltage.

NOTE: If reset button is pressed (initiates start up mode/1st ten minutes), the battery voltage is checked. If voltage is too low, product is stopped from operating and Red LED will turn on. No Red LED light indicates normal battery voltage.

7. PROBLEM: Green LED initially turns on in the control module (below deck) during start up mode, then will not appear again.

CAUSE: For the 1st ten minutes of operation (batteries inserted or reset button pressed) the Green LED will turn on when there is a target present (hands in front of sensor). After ten minutes, the Green LED will no longer turn on.

SOLUTION: This is a normal operating feature of the faucet.

Stainless ESS-2000 ESS-3000 Sinks

ESS-2100 Single Station Scrub Sink

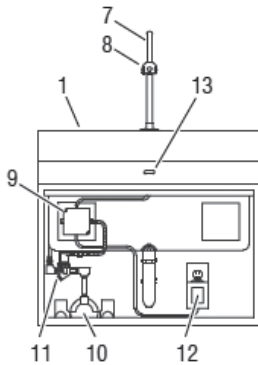

ESS-3100 Deluxe Single Station Scrub Sink

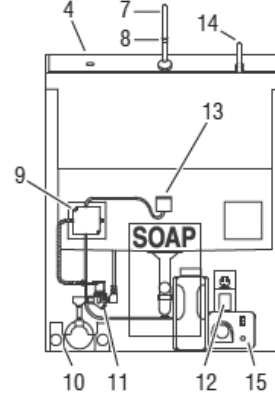

ESS-2200 Double Station Scrub Sink

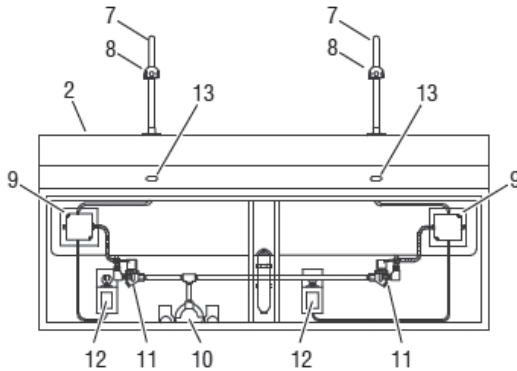

ESS-3200 Deluxe Double Station Scrub Sink

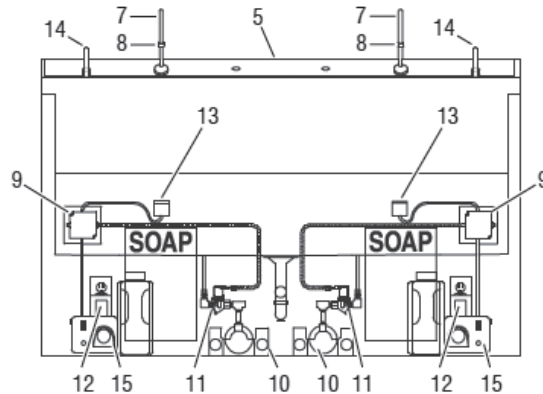

ESS-2300 Triple Station Scrub Sink

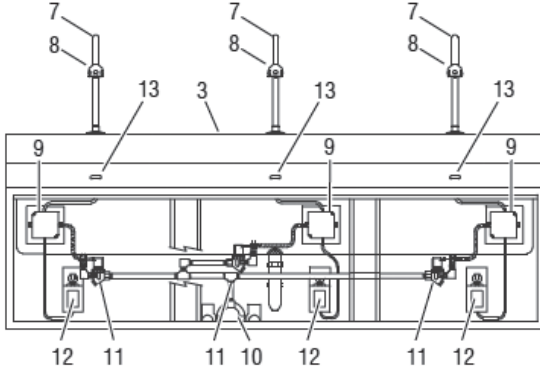

ESS-3300 Deluxe Triple Station Scrub Sink

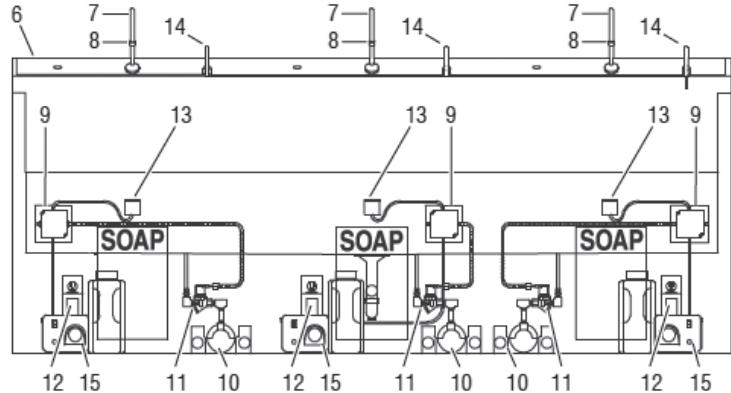

Item No.	Part No.	Description
1.	ESS-2100	Single Station Scrub Sink
2.	ESS-2200	Double Station Scrub Sink
3.	ESS-2300	Triple Station Scrub Sink
4.	ESS-3100	Deluxe Single Station Scrub Sink
5.	ESS-3200	Deluxe Double Station Scrub Sink
6.	ESS-3300	Deluxe Triple Station Scrub Sink
7.	AC-93-A	Sloan Optima® Gooseneck Faucet-Surgical Bend
8.	ETF-237	Laminar Flow Spray Head, 2.2 gpm (8.3 Lpm) Max.
	AC-55-A	Shower Spray Head, 2.2 gpm (8.3 Lpm) Max.
9.	ETF-492-A	Control Module

Item No.	Part No.	Description
10.	MIX-70-A	Below Deck Thermostatic Mixing Valve
	MIX-110-A	Above Deck Mechanical Mixing Valve
	MIX-139-A	Above Deck Thermostatic Mixing Valve
11.	ETF-370-A	Solenoid Valve
12.	ETF-233	Plug-in Transformer
13.	EL-1500-LL-S	Sensor
14.	—	Soap Dispenser Spout
15.	—	Soap Dispenser Spout Pump and Reservoir

Stainless ESS-2000 ESS-3000 Sinks

Troubleshooting the Faucet

No water flows when sensor is activated

Ensure that main power supply is turned "ON." Open control module and check diagnostic lights. Check receptacle, transformer, solenoid, leads and connections. If no lights are illuminated:

1. Control module circuit board is faulty; replace.

If green LED is illuminated and red LED illuminates when user is sensed:

1. Supply Stop(s) may be closed; open Supply Stop(s).
2. Debris may be in Solenoid Filter; remove, clean and reinstall.

If green LED is illuminated and red LED DOES NOT illuminate when user is sensed:

1. Sensor range is too long (picking up sink); reduce range.
2. Sensor is faulty; replace Sensor Module.

Very low flow or slow dribble

1. Supply Stop(s) may be closed; open Supply Stop(s).
2. Debris in Solenoid; disassemble Solenoid; clean and flush.
3. Debris may be in Solenoid Filter; remove, clean and reinstall.
4. Debris is in Aerator or Spray Head; remove, clean and reinstall.

False triggering (unit activates by itself)

1. Sensor range is too long; reduce range. Check surroundings for factors that can contribute to sensor detection problems; for example, bright lights, highly reflective surfaces, sunlight, etc.

Continues to run (even after power to faucet has been disconnected)

1. Solenoid valve is installed backwards.
2. Debris is in Solenoid, won't close properly; remove operator and clean. Reassemble Troubleshooting the Soap Dispenser

Soap does not dispense from the spout.

1. Soap reservoir is empty. Check the soap reservoir and fill if necessary.
2. Soap dispenser is not plugged in. Plug the soap dispenser power cord into the wall receptacle.
3. Power is not supplied to the wall receptacle. Check to make sure that power is being supplied to the wall receptacle.

How does one keep soap from dispensing while cleaning.

1. Unplug the soap dispenser power cord from the wall receptacle.