

**INSTALLATION INSTRUCTIONS FOR ELECTRONIC
INFRARED SENSOR ACTIVATED WALL MOUNT LAVATORY FAUCETS**

EFX-8XX

Wall Mount, Sensor Activated
Lavatory Faucets



EFX-8XX

Wall Mount, Solar Powered,
Sensor Activated Lavatory
Faucets



MODEL GUIDE OR BUILD YOUR FAUCET ONLINE AT WWW.SLOAN.COM

EFX 8 _ _ . _ 0 _ . 1 0 _ 0

—	Body Type	Power	Crown	.	Mix	Sensing	Flow Rate	.	Batteries	Base Plate*	Adapters	Drain Pop-Up
0	—	Hardwire	Bowed	.	None	Active IR	0.5 gpm (1.9 Lpm) Multi-Lam Spray Insert	.	—	None	None	No
1	—	—	—	.	Below Deck Mechanical	—	—	.	Lithium	—	US Plug-In	—
2	—	—	—	.	Below Deck Thermostatic	—	1.5 gpm (5.7 Lpm) Aerated Insert	.	—	—	UK Plug-In	—
3	—	—	—	.	—	—	1.5 gpm (5.7 Lpm) Laminar Insert	.	—	—	EU Plug-In	—
4	—	—	—	.	—	—	—	.	—	—	Box Mount	—
5	—	Battery	Solar	.	—	—	—	.	—	—	—	—
6	—	—	—	.	—	—	—	.	—	—	—	—
7	—	Solar	Solar w/LCD	.	—	—	—	.	—	—	—	—
8	Wall Mount	—	—	.	—	—	—	.	—	—	—	—

* Base Plates are not intended for the wall mount models. Wall model supplied with wall plate.

LIMITED WARRANTY

Unless otherwise noted, Sloan Valve Company warrants its products, manufactured and sold for commercial or industrial uses, to be free from defects in material and workmanship for a period of three (3) years (one (1) year for SF faucets, special finish and PWT electronics and 30 days on PWT software) from date of first purchase. During this period, Sloan Valve Company will, at its option, repair, replace, or refund the purchase price of any product which fails to conform with this warranty under normal use and service. This shall be the sole and exclusive remedy under this warranty. Products must be returned to Sloan Valve Company, at customer's cost. No claims will be allowed for labor, transportation or other costs. This warranty extends only to persons or organizations who purchase Sloan Valve Company's products directly from Sloan Valve Company for purpose of resale. This warranty does not cover the life of the battery.

THERE ARE NO WARRANTIES WHICH EXTEND BEYOND THE DESCRIPTION ON THE FACE HEREOF. IN NO EVENT IS SLOAN VALVE COMPANY RESPONSIBLE FOR ANY CONSEQUENTIAL DAMAGES OF ANY MEASURE WHATSOEVER.

PRIOR TO INSTALLATION

Prior to installing the Sloan BASYS™ Series Faucets, install the items listed below. Also, refer to rough-in illustrations.

IMPORTANT:

- ALL PLUMBING SHOULD BE INSTALLED IN ACCORDANCE WITH APPLICABLE CODES AND REGULATIONS.
- FLUSH ALL WATER LINES PRIOR TO MAKING CONNECTIONS.
- KEEP THREAD SEALANT OUT OF YOUR WATERWAY TO PREVENT COMPONENT PART DAMAGE! DO NOT USE ANY SEALANT ON COMPRESSION FITTINGS.
- DO NOT REMOVE THE SENSOR LABEL UNTIL AFTER WATER SUPPLY IS TURNED ON.

Wall Plate

The BASYS™ Wall Faucet can be installed with or without supplied wall plate.

TOOLS REQUIRED FOR INSTALLATION

- 2.5 mm hex allen wrench
- 5/8" open end wrench for female end for U.S. flex hose fittings
- Tape Measure
- Level
- #2 Philips Screwdriver
- Carpenters Square
- Drill
- Utility Knife
- Pipe Nipples
- Pipe Elbows
- Teflon Tape (NO PIPE DOPE!)

FAUCET ROUGH-IN

EFX-8XX.XOX.10X0

† EFX Faucets are available with a 0.5 gpm (1.9 Lpm) multi-laminar spray, 1.5 gpm (5.7 Lpm) aerated stream, and 1.5 gpm (5.7 Lpm) laminar stream.

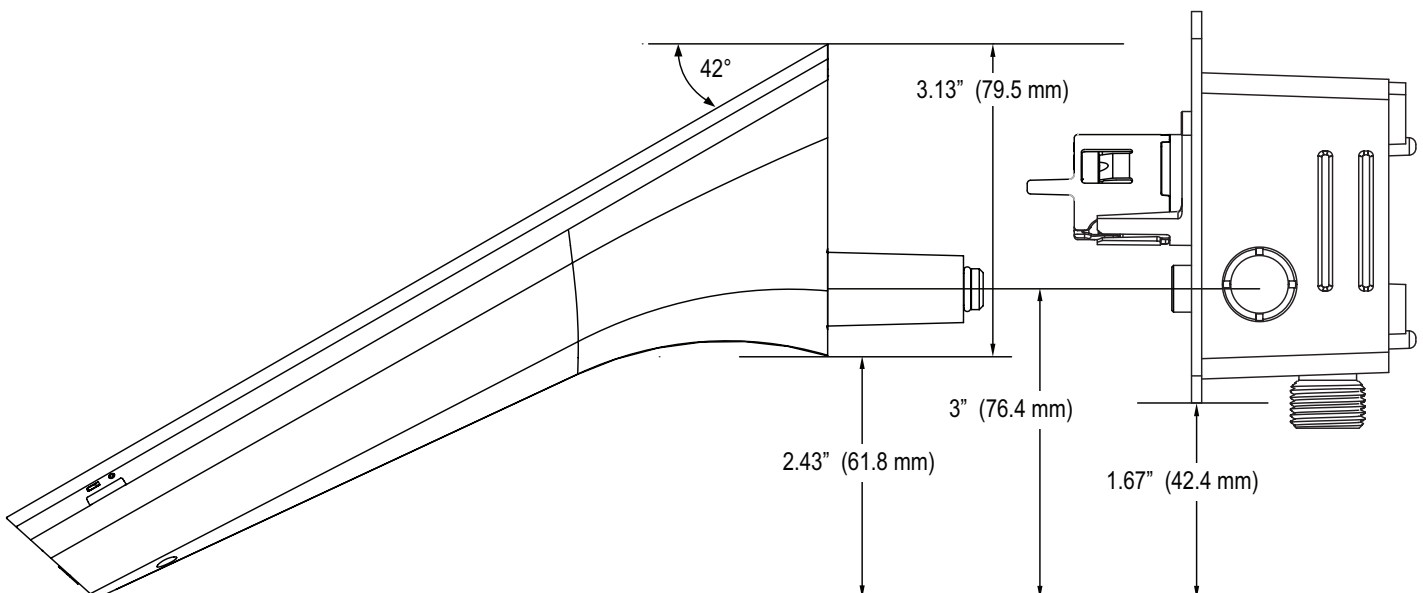
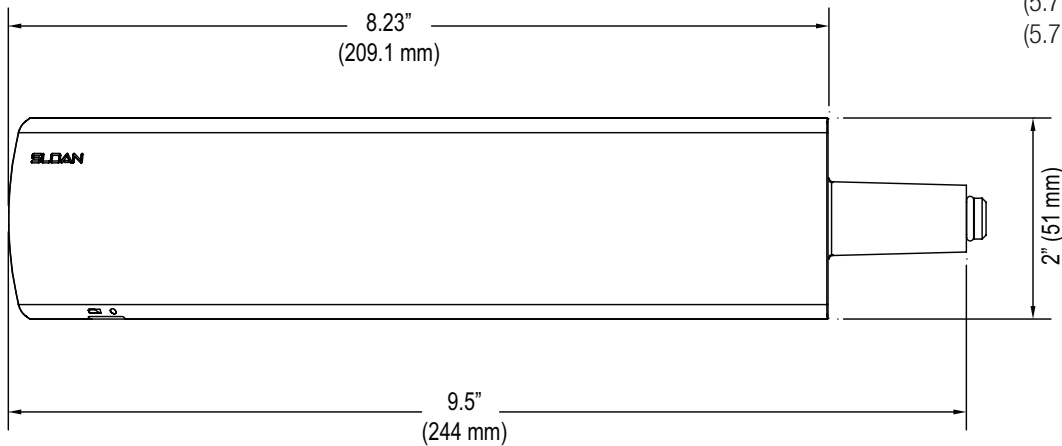

FAUCET ROUGH-IN

MOUNTING ASSEMBLY

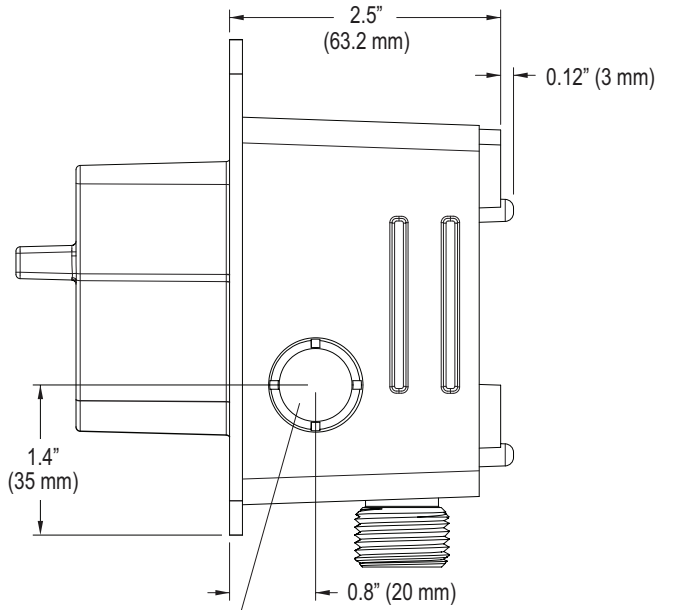
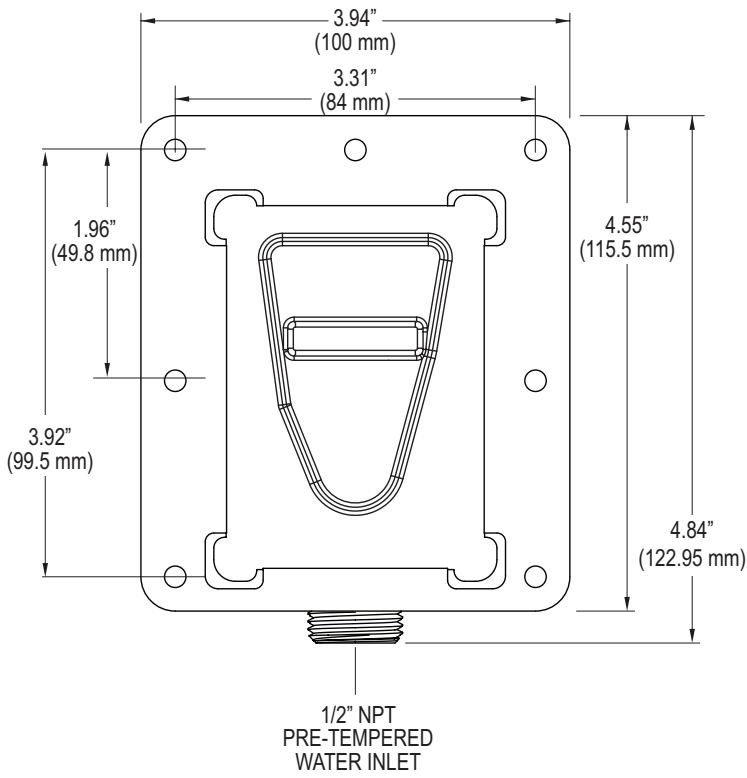

KNOCK-OUT
FOR MAIN
POWER
(2) PLACES

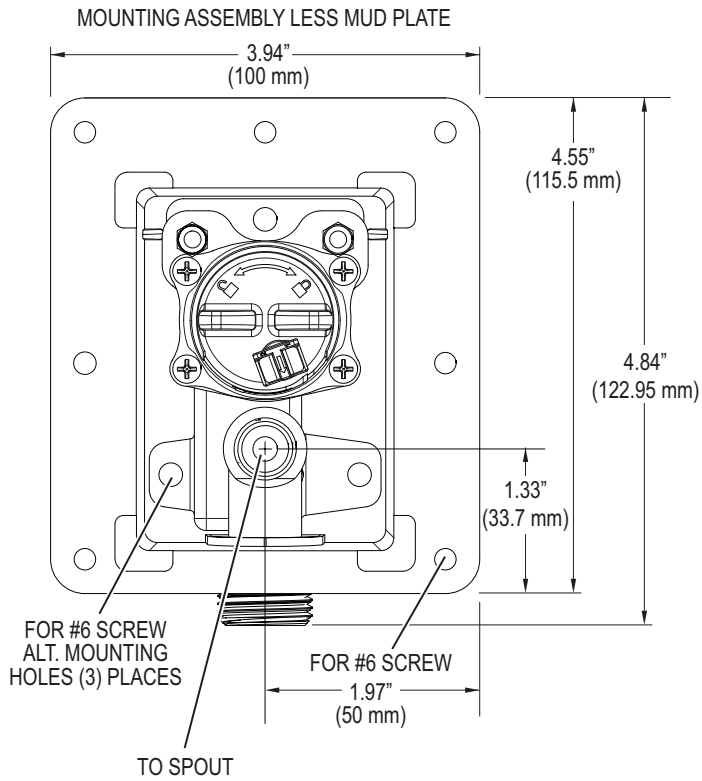

1 - PREPARE WALL

- A** Mount box to wall cavity in accordance with local building codes, ensuring box is level and centered over basin.

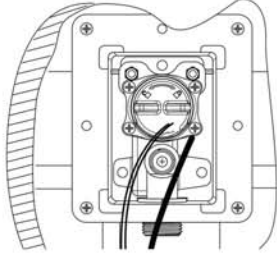

- B** Connect water supply (per codes), see Step 2.

- C** Hardwire Only - Remove one of the knockouts on the side of the mounting assembly. Route extension cable through opening per local electrical codes. Extend cable out of mounting assembly ~4" (101 mm).

- D** Loop cable and install mud guard to protect wall while finishing.

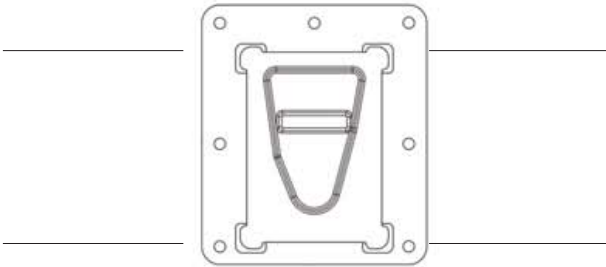

- E** Finish wall and trim mud plate flush to wall.

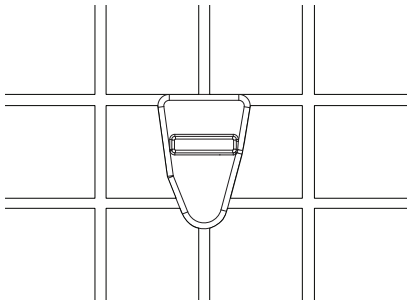

- F** Slip Spout into place. Use supplied wall plate to cover any tile gaps. Use supplied screws to attach spout wall box to two (2) places.

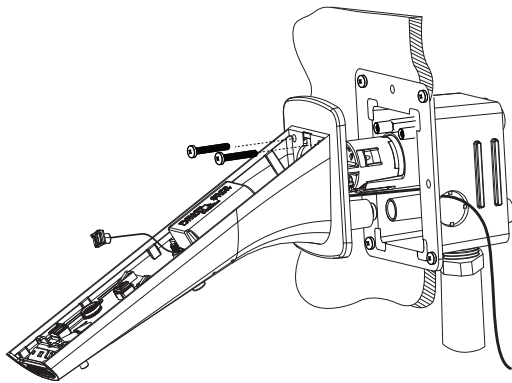

- G** Rotate solenoid cable under battery pack and insert into holder (as shown). Note the polarity.

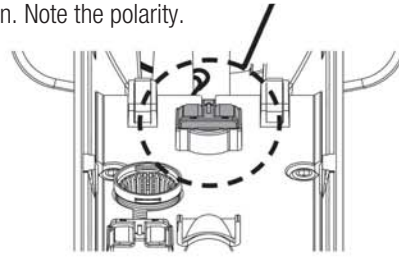

- H** Attach crown with (2) screws.

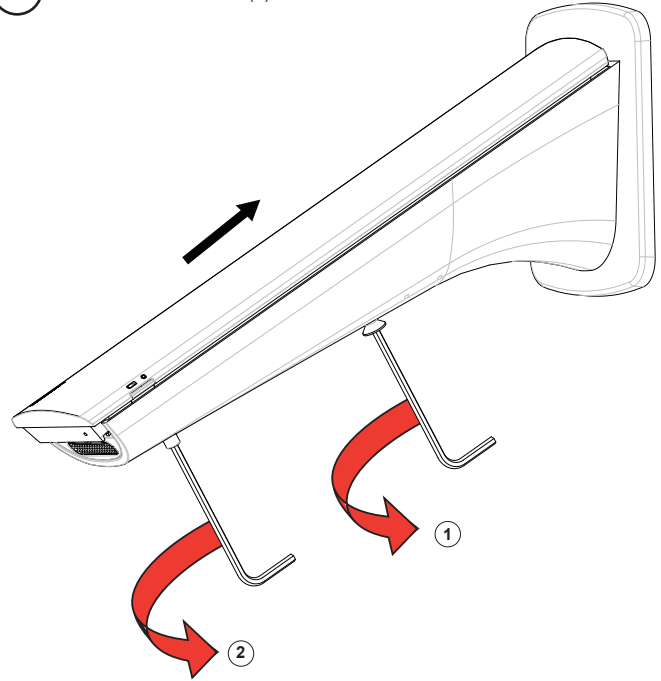

NOTES:

1. Optional Wall Flange is SUPPLIED with faucet.
2. Minimum finished wall thickness 1/16" (1.6 mm) (with wall flange).
3. Maximum finished wall thickness 1" (25.4 mm) (without wall flange).

2 - CONNECT TO WATER SUPPLY

- A** **IMPORTANT: FLUSH DIRT, DEBRIS, AND SEDIMENT FROM SUPPLY LINE(S) BEFORE CONNECTING WATER SUPPLY. A PURGE TUBE ASSEMBLY IS SUPPLIED FOR PURGE SUPPLY LINE (SEE BELOW).**

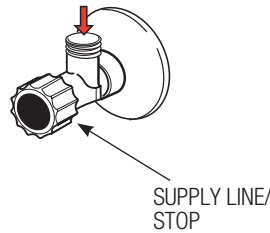

NOTE: PLEASE CHECK AND INSTALL PER LOCAL PLUMBING CODES.

NOTE: SUPPLY LINES FROM SUPPLY STOPS TO FAUCET SUPPLIED BY OTHERS.

- B** Connect check tee or mixing valve to hot and cold water supplies.

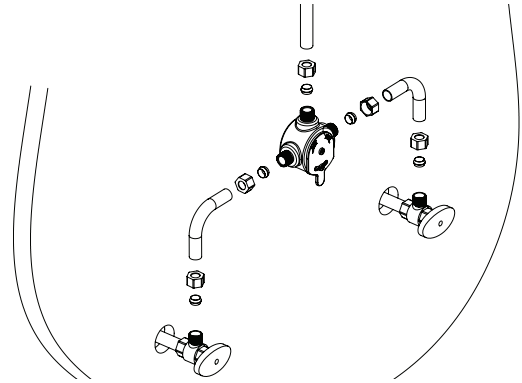

- C** Open supply stop(s).

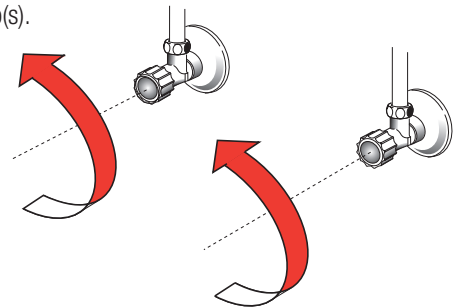

USE OF PURGE TOOL

A purge tube assembly is provided to purge the supply line.



- A** After water supply is connected, open the supply stop(s). Rotate the solenoid caddy counter-clockwise to a 45° angle to align with the arrow. Remove solenoid caddy from the faucet.

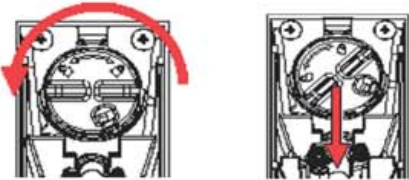

- B** Insert the purge tube assembly at a 45° angle and rotate it clockwise to align with the arrow. Flush water to remove all dirt and debris from the line.

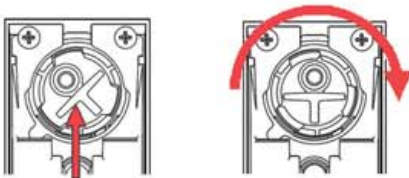

- C** Rotate the purge tube assembly counter-clockwise to a 45° angle and remove from the faucet.

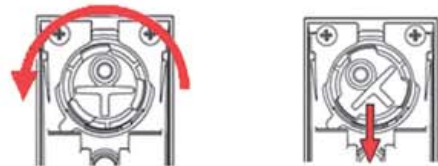

- D** Insert the solenoid caddy at a 45° angle and rotate it clockwise to align with the arrow. Locking the unit and opening the water path.

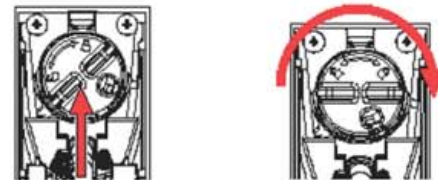

- E** Route the solenoid cable under the battery pack and insert into the holder (as shown). Note the polarity.

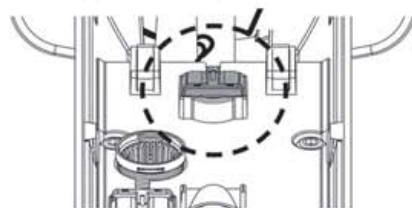

3 - START-UP SEQUENCE

- A** For Hardwire Models, plug adapter into receptacle or use box style adapter.

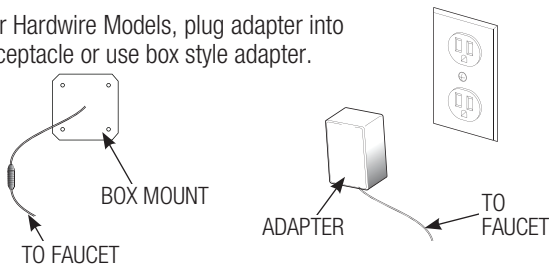

- B** Remove label from sensor window.

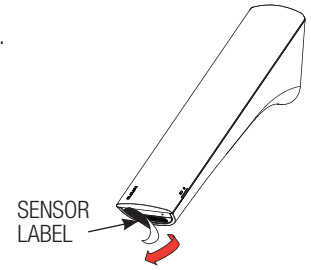

- C** Activate faucet by holding installation instructions approximately 1-1/2" (38 mm) in front of sensor window until Red LED turns on then remove instructions while faucet senses its surroundings. Wait for green LED on side of faucet.

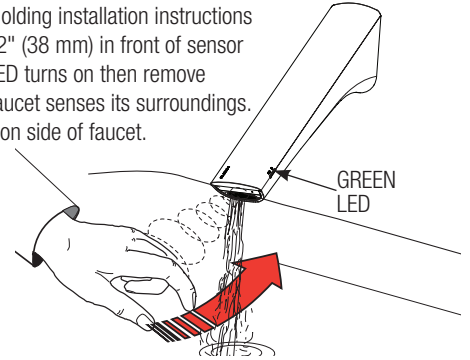

- D** Activate faucet and check for leaks. If faucet DOES NOT function, refer to the troubleshooting section.

NOTE: HARDWIRE FAUCETS SUPPLIED WITH ONE (1) 47" (1.2 m) EXTENSION CABLE.

NOTE: EXTENSION CABLES AVAILABLE SEPARATELY.

NOTE: USE ONLY SLOAN SUPPLIED POLARIZED AND KEYED CABLE ASSEMBLIES.

IMPORTANT: CUTTING AND SPLICING WIRES WILL VOID WARRANTY.

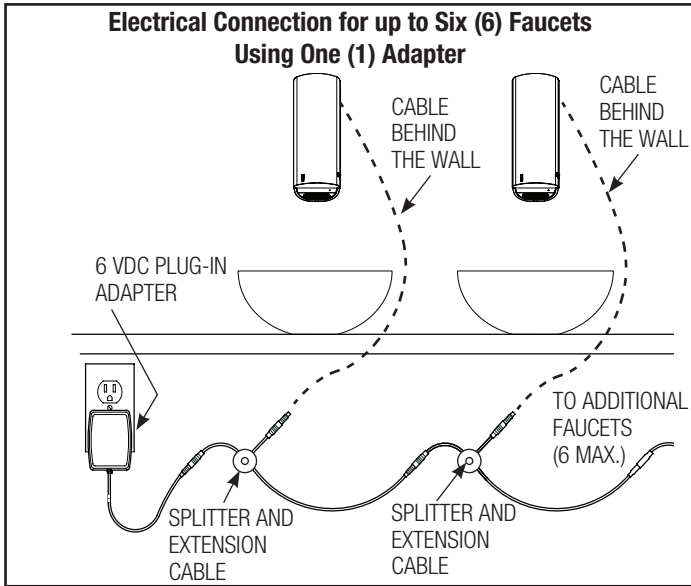

ADDITIONAL FUNCTIONS

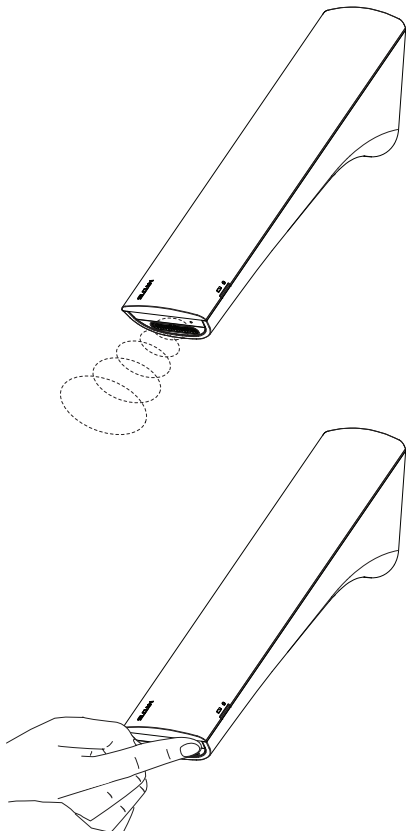

Function	Steps to Activate Function	Default Setting	IR Clic
IR Activation	Cover IR clic approximately for 2 sec. until LED will flash GREEN 1x - then remove finger from IR clic (Active for 5 sec.)	—	—
Cleaning Mode	IR Activation; Cover IR clic 2x - confirmation of the function is active by a couple flashes by the LED; to return to normal operation cover IR clic 1x or the faucet will automatically return to normal function after 2 min.	2 min.	—
12/24 Line Purge Feature	See below.	Off	Off 12HR 24HR
Sensor Range Adjustment	See page 7.	6	1-8
Reset Electronics	IR Activation Cover IR clic 2x; LED will flash 5x Cover IR clic 1x for 5 sec. until LED flashes 4x, then remove finger from IR clic Wait for 20 sec. (After 10 sec. water will flow for 6 sec. and automatically adjust to environment)	Manually	—
Security Off	After 90 seconds (max) of hand and/or object within sensor appears permanent, waterflow will stop and will remeasure environment	On	—

Please contact factory for more extensive programming options.

12/24 LINE PURGE FEATURE

This feature will operate the faucet every 12 or 24 hours since last use, if not used to prevent stagnant water conditions.

Default purge duration is two minutes.

Consult factory regarding other timing options.

- A** IR activation (see above). Cover IR clic approximately 24 sec. (ignore LED indications during this period). Release when requested program is reached. (See diagram to right). Programming mode will time out after 2 minutes if no changes are made.

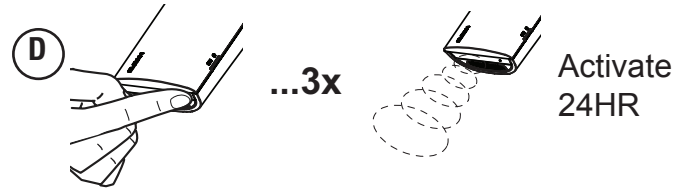
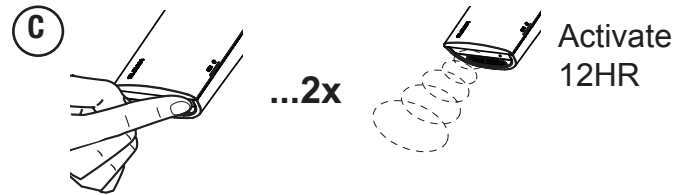
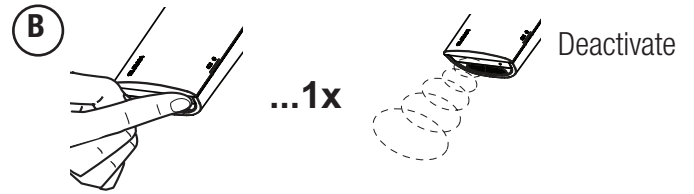
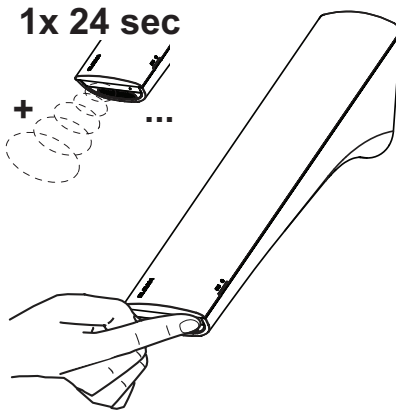

SENSOR RANGE ADJUSTMENT

FACTORY SETTING IS APPROPRIATE FOR THE MAJORITY OF APPLICATIONS AND SHOULD NOT REQUIRE RESETTING UNLESS UNDER EXTREME SITUATIONS: HIGH REFLECTION OR LOW LIGHT.

- A** IR Activation (see page 5). To enter programming mode place finger on IR clic for 2 times then remove. Light on side of crown should blink to indicate programming mode.

2x +
1x 5 sec

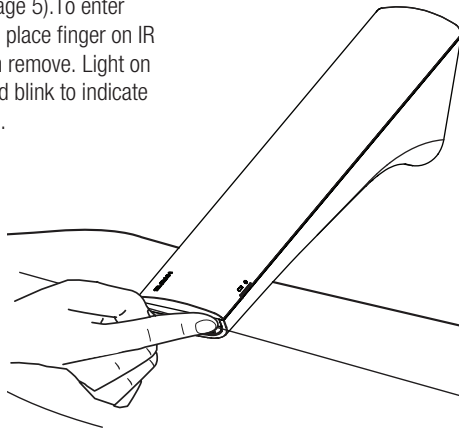

- B** Cover IR clic until LED flashes RED 4 times – hold IR clic until LED flashes 1 time to 8 times from minimum to maximum range. See diagram below. Release when requested range is reached.

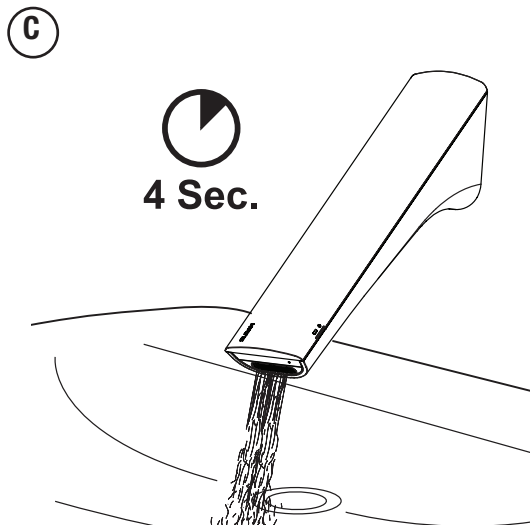
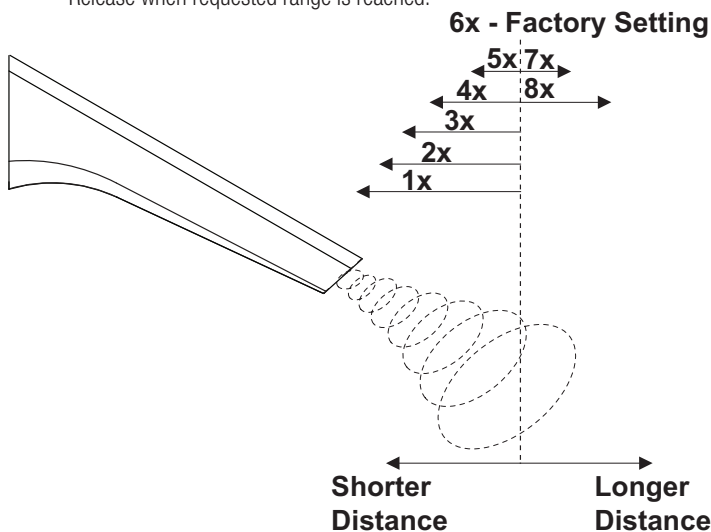

- D** Wait, until LED flashes GREEN.

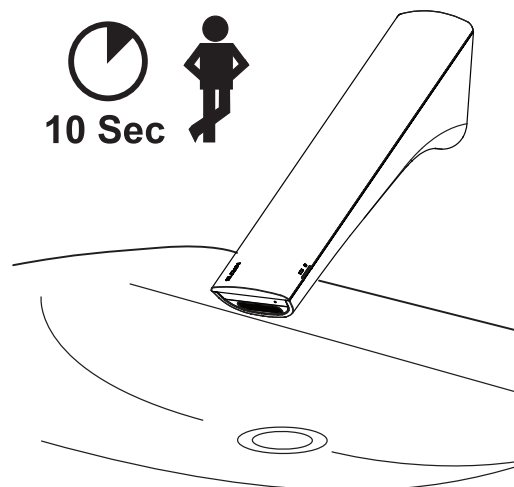

BATTERY REPLACEMENT

NOTE: Replace Battery when LED1 indicator flashes red each time faucet is in use or when faucet stops functioning. LED1 is identified by the battery symbol.

NOTE: Turning off water is not necessary.

- A** Remove crown by loosening 2 hex screws located on underside of spout and slide crown down and lift off.

NOTE: Screw is captive within faucet body and will NOT fall out.

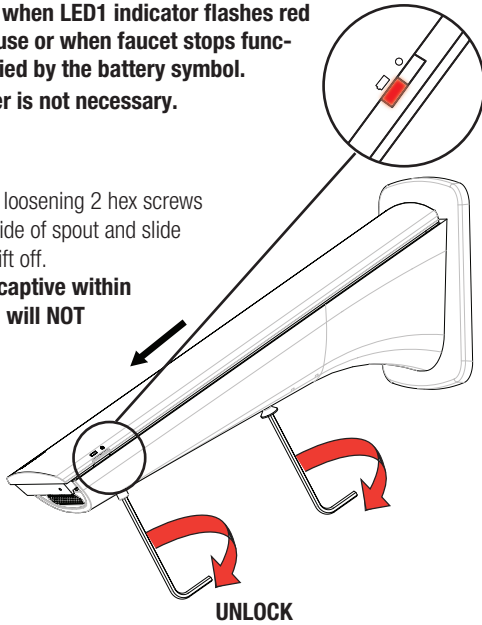

- B** Remove red cover over the battery. Remove battery holder from the faucet body. Replace battery in the holder. Holder drops into the faucet body. Place the red cover over the battery.

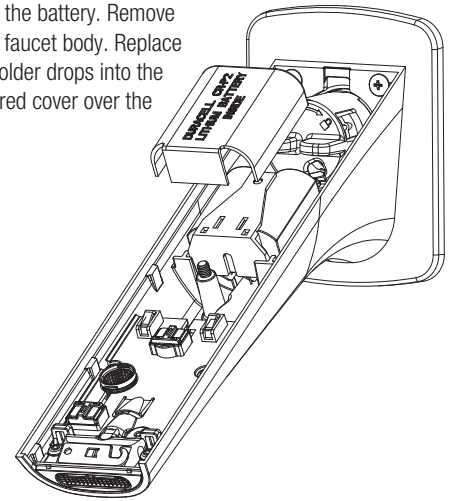

- C** Slide on crown and secure in 2 places.

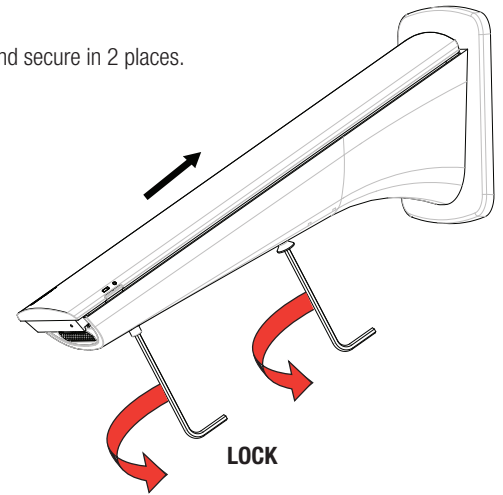

REPLACING THE SOLENOID/FILTER

NOTE: TURNING OFF WATER IS NOT NECESSARY, DUE TO INTEGRATED AUTOMATIC STOP VALVE.

- A** Remove crown by loosening hex screw located on underside of spout and slide crown down and lift off.

NOTE: Screw is captive within faucet body.

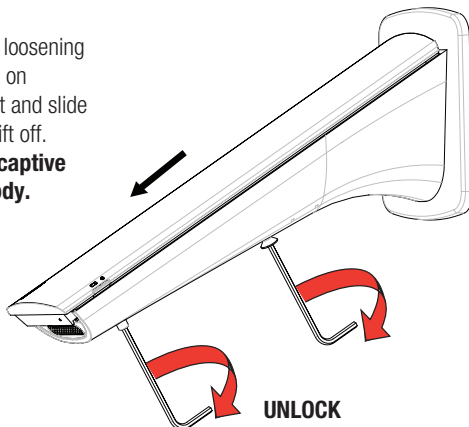

- C** Pull solenoid caddy from faucet.

NOTE: Strainer can be removed, cleaned and replaced at this time.

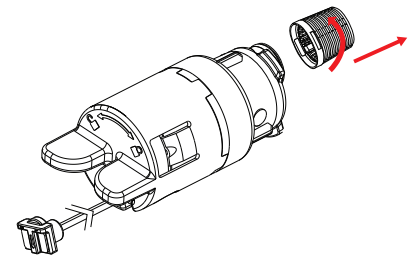
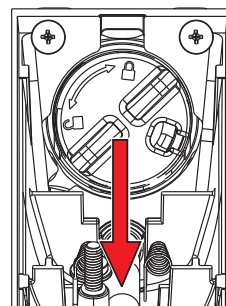

- B** Rotate solenoid assembly counter-clockwise through a 45° angle.

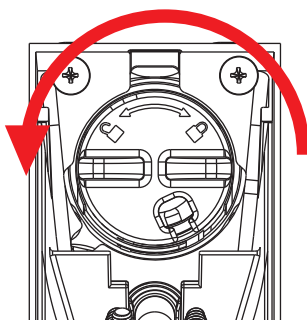

- D** Insert new solenoid caddy at a 45° angle.

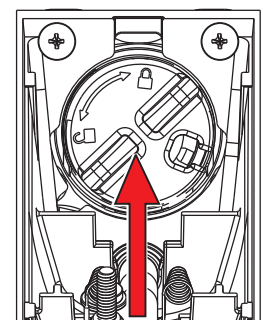

REPLACING THE SOLENOID/FILTER (CONTINUED)

- E** Rotate solenoid caddy clockwise to align with arrow, locking the unit and opening water path.

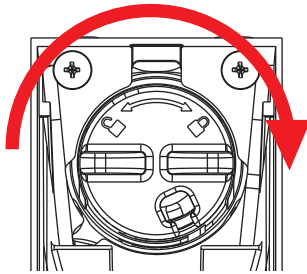

- F** Slide on crown and secure in 2 places.

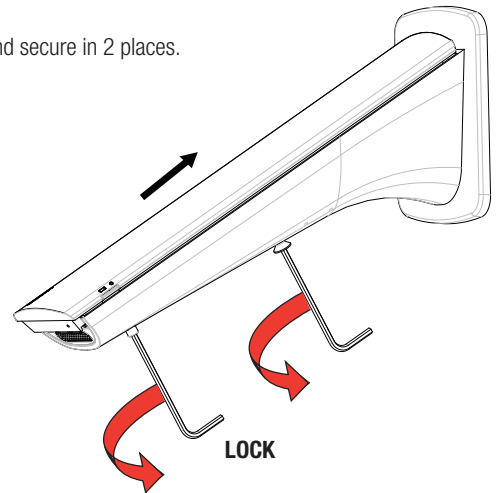

REPLACE SPRAY INSERT

NOTE: TURNING OFF WATER IS NOT NECESSARY, DUE TO INTEGRATED AUTOMATIC STOP VALVE.

- A** Remove crown by loosening hex screw located on underside of spout and slide crown down and lift off.
NOTE: Screw is captive within faucet body.

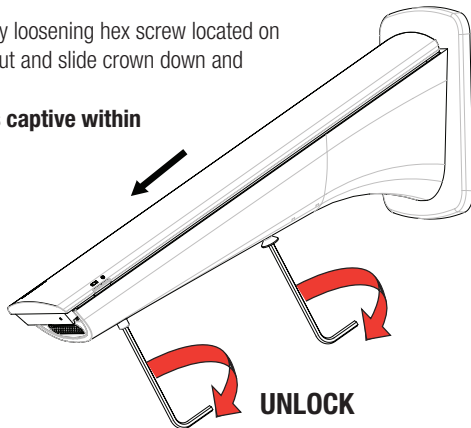

- B** Retrieve spray removal tool located near the spray insert.

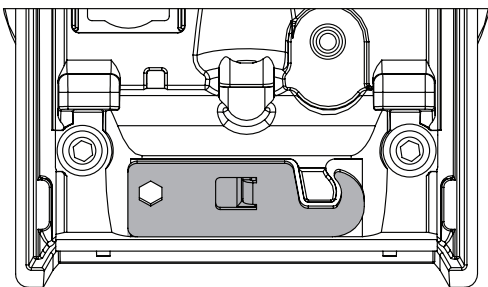

- C** Insert spray removal tool into spray slot by sliding hook end of key between faucet spout and insert. Pull insert out of faucet once hooked.

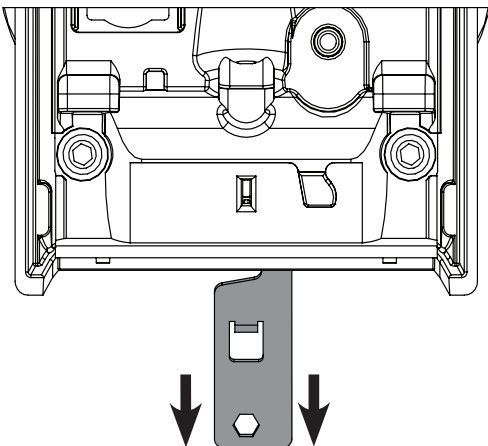

- D** Install new insert.
NOTE: If changing to a different flow rate solenoid caddy must also be changed.

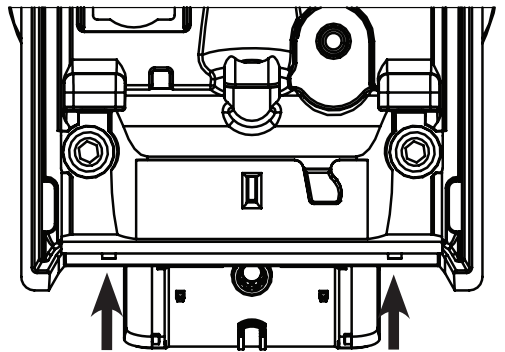

- E** Return spray removal tool to storage location.
NOTE: This can only be done once spray head is installed. This will lock the spray head in place.
NOTE: If spray head is inserted incorrectly – key will not lock in properly. Turn faucet on to push insert out and re-install.

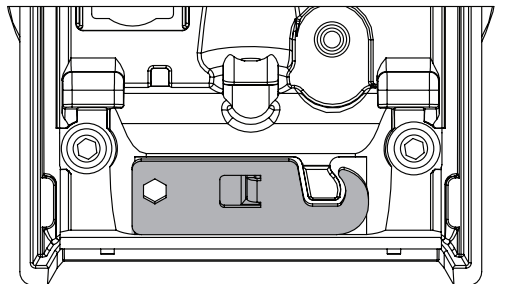

- F** Slide on crown and secure.

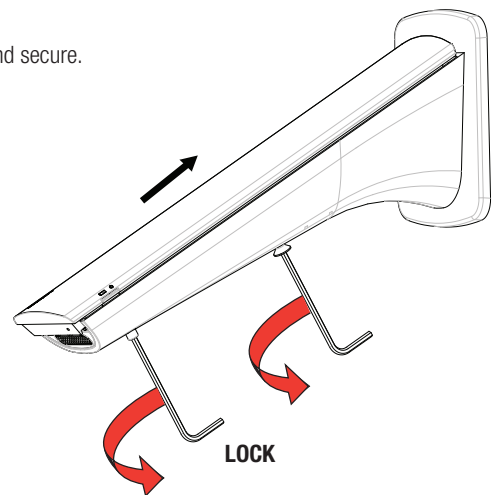

UPGRADE FAUCET FUNCTIONALITY

- A** Remove crown by loosening hex screw located on underside of spout and slide crown down and lift off.

NOTE: Screw is captive within faucet body.

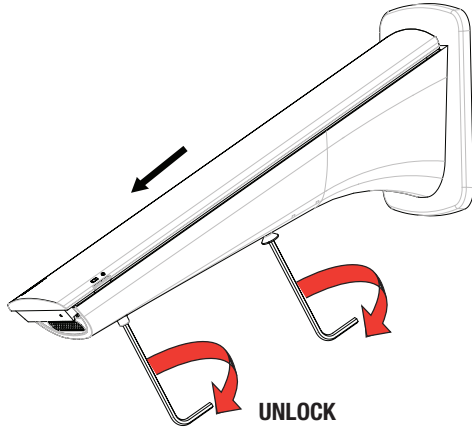

- B** Place new crown on faucet by sliding onto spout and tightening hex screw on underside of spout.

NOTE: All electronics are fully encapsulated in the crown and thus protected from the environment and easy to replace or upgrade.

- C** Activate faucet by holding installation instructions approximately 1-1/2" (38 mm) in front of sensor window until Red LED turns on then remove instructions while faucet senses its surroundings. Wait for green LED on side of faucet.

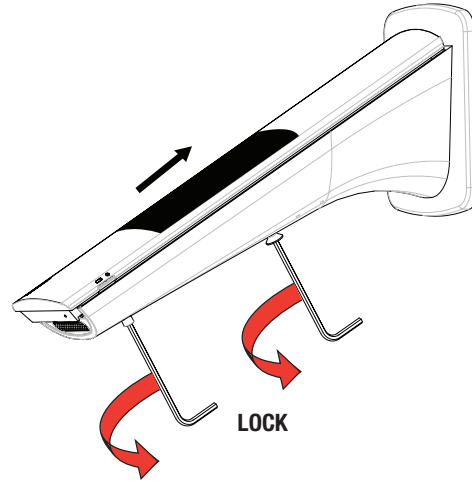

LED DISPLAY DIAGNOSTIC CODES

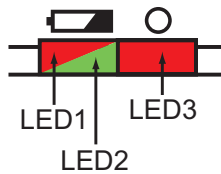

Function	LED1	LED2	LED3	Description 1	Description 2
Start Up Boot				LED1 and LED2 alternate blinking	Fast Toggle
Battery Check after Start Up				LED1 on for 2 sec, if battery greater than 3.5V	
Line Power Check after Start Up				LED3 on for 2 sec, if line power is greater than 3.5V	
IR Adjust Process				LED1 blinking while IR adjusts	Few seconds
IR Adjust OK				LED2 on for 2 sec, if adjustment OK	
Battery Low				LED1 blinks 3x, if battery is less than warning level	Only while in detection mode
Battery Empty				LED1 double flashes 3x, if battery is less than empty level	Only while in detection mode
Valve Error				LED3 double flashes 3x, if valve current error; flash after the 3rd error, off after the 3rd good operation	Flashes after the 3rd error, off after the 3rd good operation
IR Activation				LED2 on for 2 sec, if IR-click has been activated	After 5 sec. automatically back to operating mode
Cleaning Mode				LED1 4-in-1 flash, if cleaning mode is activated	During "Cleaning Mode" is activated Permanent 4-in-1 flashes

TROUBLESHOOTING GUIDE

- 1. Red LED in spout does not blink 2 seconds after battery installation. Battery placement incorrect or batteries have been discharged.**
Ensure lithium batteries are installed properly. Check the orientation of each battery matches the positive (+) and negative (-) symbols shown on the battery compartment.
- 2. Faucet DOES NOT function. Adhesive packaging label affixed over sensor eye.**
Remove adhesive label from sensor eye.
- 3. Faucet delivers water in an uncontrolled manner. Faucet is not working properly.**
Clean sensor window; if problem persists contact Sloan Tech Support (see below).
- 4. Faucet DOES NOT deliver any water when sensor is activated. Solenoid valve produces an audible "CLICK".**
 - A. Water supply stop(s) closed.**
Open water supply stop(s).
 - B. Strainer is clogged.**
Remove, clean, and reinstall strainer. Replace strainer (filter), if needed (refer to page 8).**Solenoid valve DOES NOT produce an audible "CLICK".**
 - A. Batteries low (battery powered models).**
Replace batteries (refer to battery replacement on page 7).
 - B. Power failure (hardwire models).**
Check power supply.
- 5. Faucet delivers only a slow flow or dribble when sensor is activated. Water supply stop(s) are partially closed.**
Completely open water supply stop(s).
- 6. Faucet DOES NOT stop delivering water or continues to drip after user is no longer detected. Faucet is not working properly.**
Clean sensor window; if problem persists contact Sloan Tech Support (see below).
- 7. LED indicator blinks RED when faucet is in use. Batteries low (battery powered models).**
Replace batteries (refer to battery replacement on page 7).
- 8. The water temperature is too hot or too cold on a faucet connected to hot and cold water supply lines.**
 - A. Supply stops are not adjusted properly.**
Adjust supply stops.
 - B. For models with integral side mixing valve – mixing valve is set improperly for the water temperature desired.**
Rotate mixing valve handle clockwise to decrease water temperature or counterclockwise to increase water temperature.
 - C. Inadequate hot water supply.**
Adjust supply stops.

When assistance is required, please contact Sloan Technical Support at:
1-888-SLOAN-14 (1-888-756-2614)

OPERATION

As the user's hands enter the beam's effective range, the beam is reflected back into the sensor receiver and activates the solenoid valve allowing water to flow from the faucet. Water will flow until the hands are removed or until the faucet reaches its automatic time out limit setting, if hands remain in sensor range.

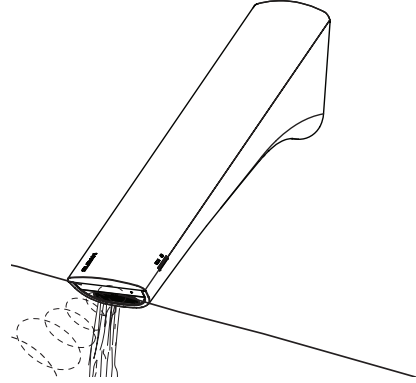

CARE AND CLEANING

DO NOT USE abrasive or chemical cleaners (including chlorine bleach) to clean faucets that may dull the luster and attack the chrome or special decorative finishes. Use **ONLY** mild soap and water, then wipe dry with clean cloth or towel. While cleaning the bathroom sink, protect the faucet from any splattering of cleaner. Acids and cleaning fluids will discolor or remove chrome plating.

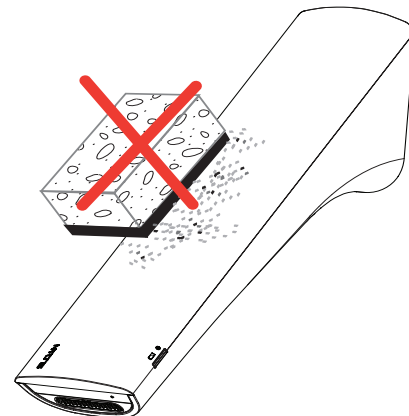

PARTS LIST

Item #	Part #	Description
1	—	Wall Mount Faucet Assembly
2	EFX-1002-A	0.5 gpm/1.9 Lpm Multi-Lam Spray Insert (includes insert, o-ring, 2.5 mm allen key, and removal tool)
	EFX-1001-A	1.5 gpm/5.7 Lpm Aerated Stream Insert (includes insert, o-ring, 2.5 mm allen key, and removal tool)
	EFX-1000-A	1.5 gpm/5.7 Lpm Laminar Stream Insert (includes insert, o-ring, 2.5 mm allen key, and removal tool)
3	EFX-1011-A	0.5 gpm/1.9 Lpm Solenoid Valve Caddy Assembly – Wall (Green)
	EFX-1012-A	1.5 gpm/5.7 Lpm Solenoid Valve Caddy Assembly – Wall (Blue)
4	EFX-19	Strainer (Filter)
5	EFX-1013-A	Mounting Assembly
6A	EFX-1009-A	Bowed Crown Assembly
6B	EFX-1010-A	Solar Crown Assembly
6C	EFX-1018-A	Solar Crown with LCD Assembly
7	EFX-1015-A	CR-P2 Lithium Battery
8	MIX-60-A	Mechanical, Below Deck Mixing Valve
9	MIX-135-A	Thermostatic, Below Deck Mixing Valve
10	ETF-617-A	Bak-Chek Tee Assembly
11	EAF-23-A	Splitter
12	EAF-24-A	11-13/16" (300 mm) Extension Cable
	EAF-25-A	47-1/4" (1200 mm) Extension Cable
	EAF-17-A	126" (3200 mm) Extension Cable
13	EAF-11	Plug-in Voltage Adapter (US)
	EAF-39	Plug-in Voltage Adapter (UK)
	EAF-41	Plug-in Voltage Adapter (EU)
	EAF-37	Box Mount Adapter
14	—	Purge Tool

NOTE: If changing flow rate caddy and spray insert must be changed in conjunction.

† Single Supply faucets include Bak-Chek®

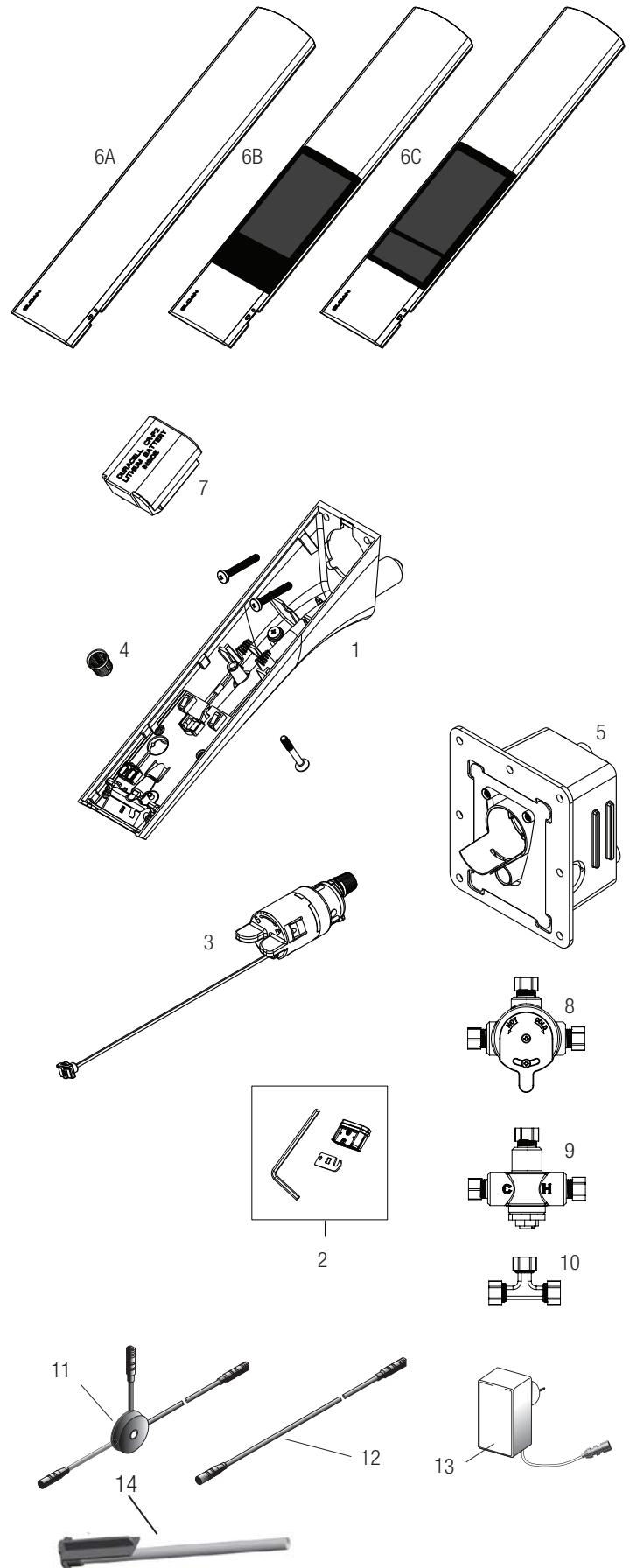

Manufactured by Sloan Valve Company under one or more of the following patents: U.S. Patents. Other Patents Pending. BAK-CHEK®, BASYS™, Any Application. Any Environment.™

The information contained in this document is subject to change without notice.

SLOAN • 10500 SEYMOUR AVENUE • FRANKLIN PARK, IL 60131

Phone: 1-800-9-VALVE-9 (1-800-982-5839) • Fax: 1-800-447-8329 • www.sloan.com