

**INSTALLATION INSTRUCTIONS FOR ELECTRONIC
CAPACITANCE SENSING LAVATORY FAUCETS**



EFX-3XX
Pedestal, Sensor
Activated Lavatory
Faucets



EFX-6XX
Integrated Base,
Sensor Activated
Lavatory Faucets

MODEL GUIDE

EFX **0** . **1** . **0** **0**

—	Body Type	Power	Crown	.	Mix	Sensing	Flow Rate	.	Batteries	Base Plate	Adapters	Drain Pop-Up
0	—	Hardwire	Bowed	.	None	—	0.5 gpm Multi-Lam	.	Alkaline	None	None	No
1	—	—	—	.	Below Deck Mechanical	Capacitance	—	.	—	4-inch†	US Plug-in	—
2	—	—	—	.	Below Deck Thermostatic	—	1.5 gpm (5.7 Lpm) Aerated Insert	.	—	8-inch†	—	—
3	Pedestal	—	—	.	—	—	1.5 gpm (5.7 Lpm) Laminar Insert	.	—	—	—	—
4	—	—	—	.	—	—	—	.	—	—	—	—
5	—	Battery	—	.	—	—	—	.	—	—	—	—
6	Integrated Base	—	—	.	—	—	—	.	—	—	—	—
7	—	—	—	.	—	—	—	.	—	—	—	—
8	—	Turbine	—	.	—	—	—	.	—	—	—	—

† Base Plates are not intended for the integrated base models.

LIMITED WARRANTY

Unless otherwise noted, Sloan Valve Company warrants this product, manufactured and sold for commercial or industrial uses, to be free from defects in material and workmanship for a period of three (3) years (1 year for SF faucets, special finish and PWT electronics and 30 days on PWT software) from date of first purchase. During this period, Sloan Valve Company will, at its option, repair, replace, or refund the purchase price of any product which fails to conform with this warranty under normal use and service. This shall be the sole and exclusive remedy under this warranty. Products must be returned to Sloan Valve Company, at customer's cost. No claims will be allowed for labor, transportation or other costs. This warranty extends only to persons or organizations who purchase Sloan Valve Company's products directly from Sloan Valve Company for purpose of resale. This warranty does not cover the life of the battery.

THERE ARE NO WARRANTIES WHICH EXTEND BEYOND THE DESCRIPTION ON THE FACE HEREOF. IN NO EVENT IS SLOAN VALVE COMPANY RESPONSIBLE FOR ANY CONSEQUENTIAL DAMAGES OF ANY MEASURE WHATSOEVER.

PRIOR TO INSTALLATION

Prior to installing the Sloan BASYS[™] Series Faucets, install the items listed below. Also, refer to rough-in illustrations.

IMPORTANT:

- **ALL PLUMBING SHOULD BE INSTALLED IN ACCORDANCE WITH APPLICABLE CODES AND REGULATIONS.**
- **FLUSH ALL WATER LINES PRIOR TO MAKING CONNECTIONS.**
- **KEEP THREAD SEALANT OUT OF YOUR WATERWAY TO PREVENT COMPONENT PART DAMAGE! DO NOT USE ANY SEALANT ON COMPRESSION FITTINGS.**

Base Plates

When the BASYS[™] Faucet is installed on a sink that has three (3) hole punchings, a base plate should be used. **Base Plates should be specified at the time of ordering.**

- EFX-20-A – 4" (102 mm) Centerset Sinks
- EFX-26-A – 8" (203 mm) Centerset Sinks

IMPORTANT

Not for installation on a metal sink or deck (i.e. stainless steel or cast metal).

TOOLS REQUIRED FOR INSTALLATION

- 13 mm open end wrench or nut driver for faucet retainer nut
- 2.5 mm hex allen wrench
- 5/8" open end wrench for female end of flex hose

FAUCET ROUGH-IN

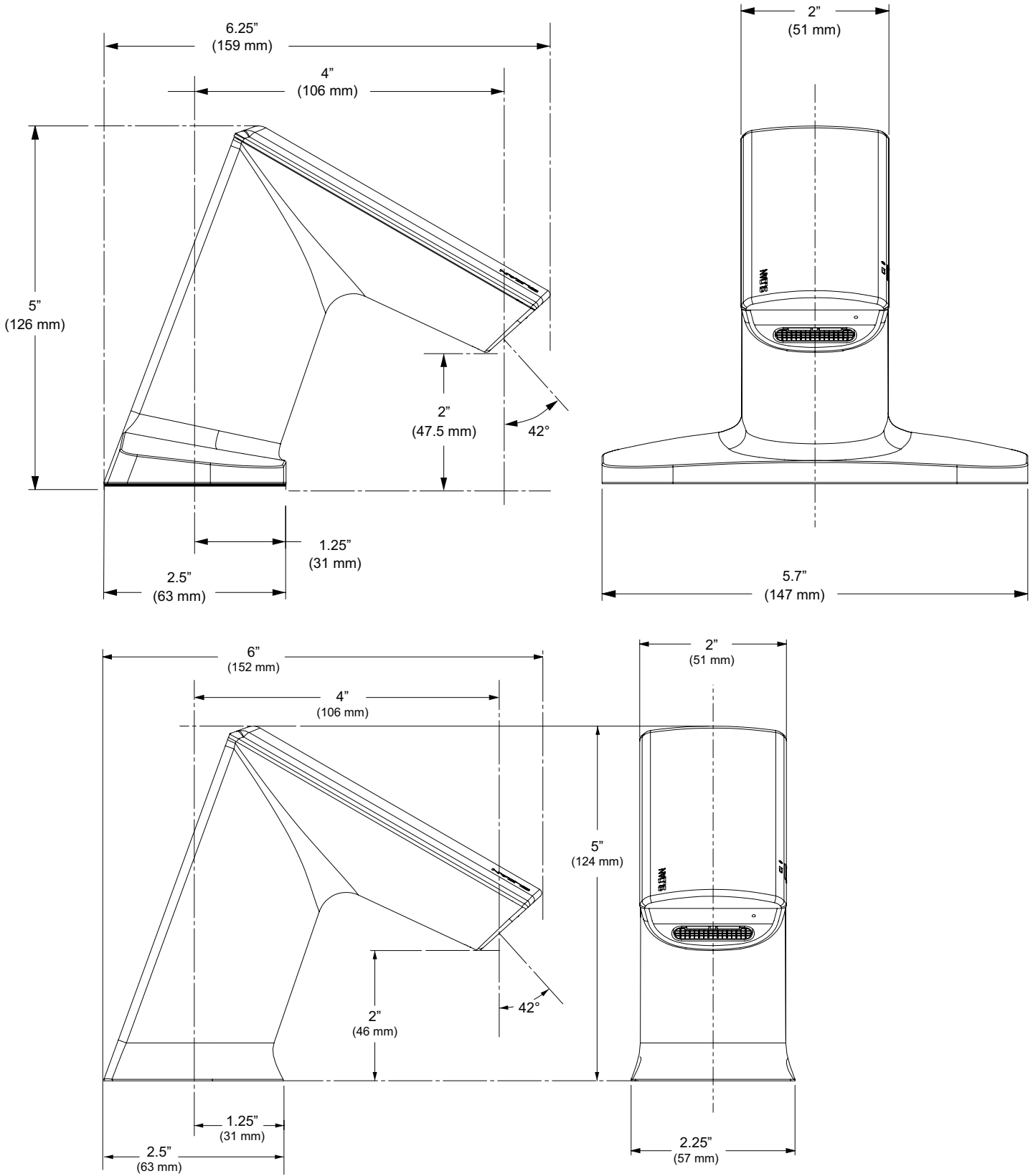

FAUCET ROUGH-IN (CONTINUED)

**EFX-3X0.X1X.0000
WITH HOT/COLD
WATER SUPPLY**

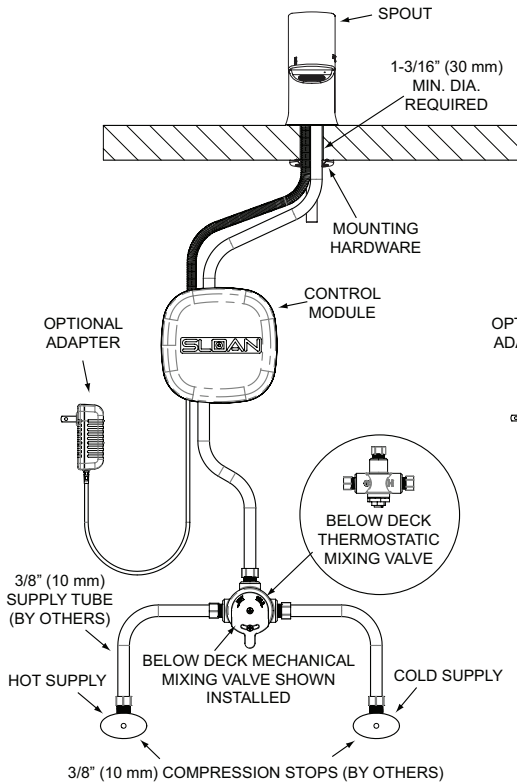

**EFX-3X0.01X.0100
WITH TEMPERED WATER
SUPPLY AND 4-INCH BASE
PLATE**

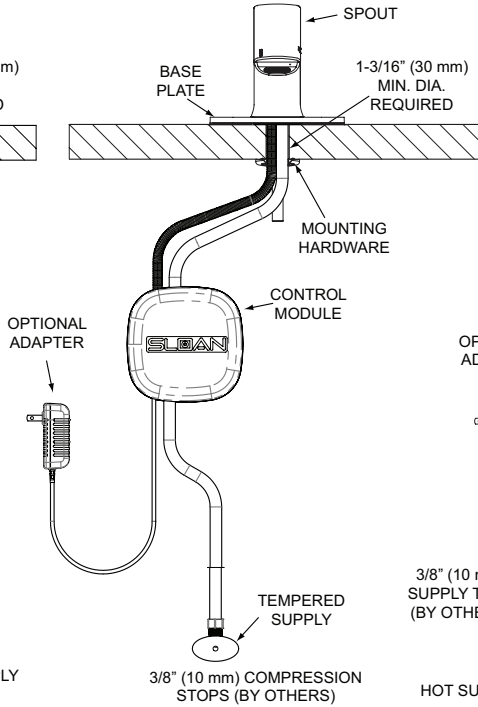

**EFX-6X0.X1X.0000
WITH HOT/COLD
WATER SUPPLY**

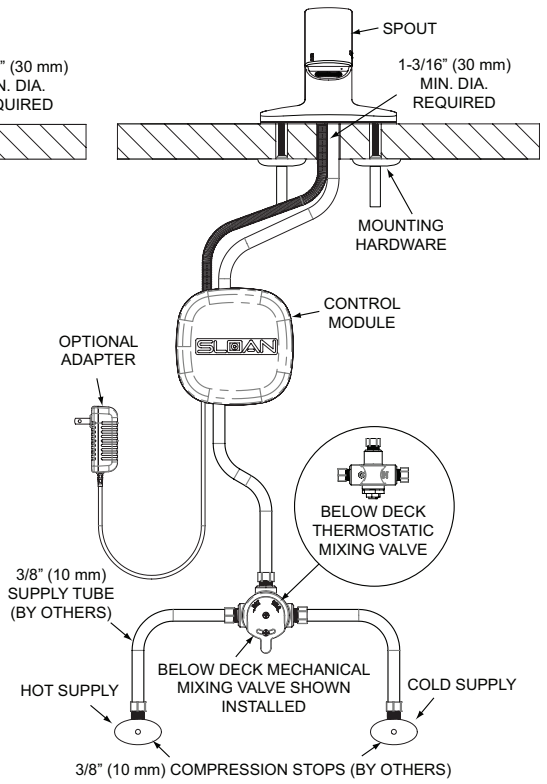

IMPORTANT
Not for installation on a metal sink or deck (i.e. stainless steel or cast metal).

† EFX Faucets are available with a 0.5 gpm (1.9 Lpm) multi-laminar spray, 1.5 gpm (5.7 Lpm) aerated stream, and 1.5 gpm (5.7 Lpm) laminar stream.

1 - INSTALL FAUCET AND MOUNT CONTROL MODULE

- A** Remove nut, faucet retainer and gasket.
- B** Install faucet into the center hole in deck or lavatory – 1-3/16" (30 mm) minimum hole required.
- C** Install mounting bracket under deck or lavatory ensuring there is enough clearance for the flexible supply hose from the faucet to connect to the control module. Install control module at a 45° angle and turn right to secure.

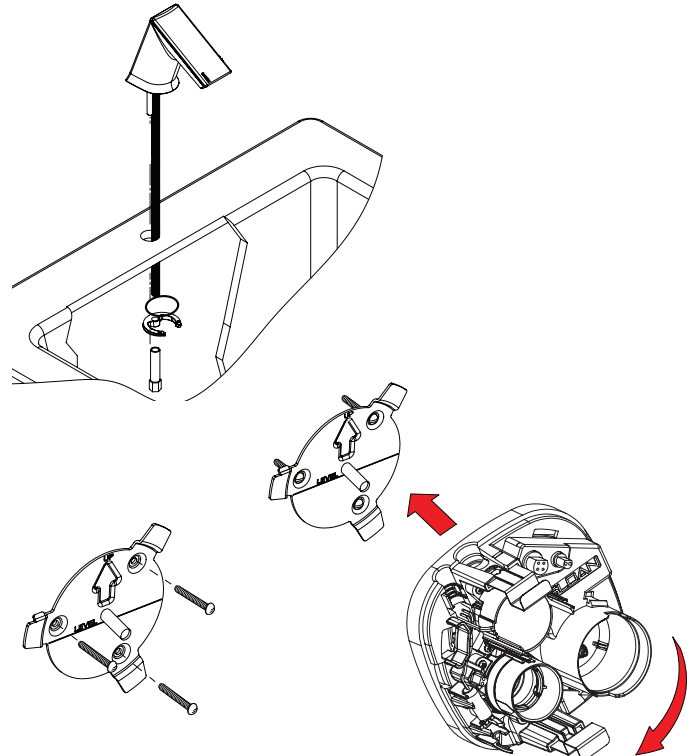

2 - INSTALL FLEX HOSE ASSEMBLY TO SUPPLY STOP AND CONTROL MODULES

- A** Connect LED power plug and capacitance plug to control module.

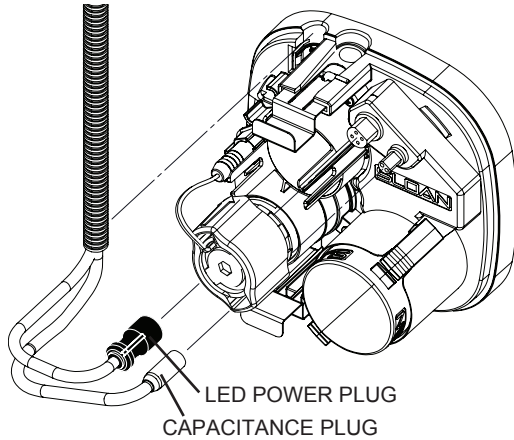

IMPORTANT:

- IF CAPACITANCE PLUG/WIRE IS BENT/DAMAGED/ BROKEN FAUCET WILL NOT WORK.
- ENSURE CAPACITANCE WIRE IS AT LEAST 1/2" FROM ANY METAL, SUCH AS WATER SUPPLY.
- FLUSH DIRT, DEBRIS AND SEDIMENT FROM SUPPLY LINE(S) BEFORE CONNECTING FLEX HOSES.

- B** Install flex hose(s) onto supply stop(s). Connect hot and cold supply stop hoses to mixing valve and flex hose to connect to control module.

- C** Tighten the flex hose securely to the supply.

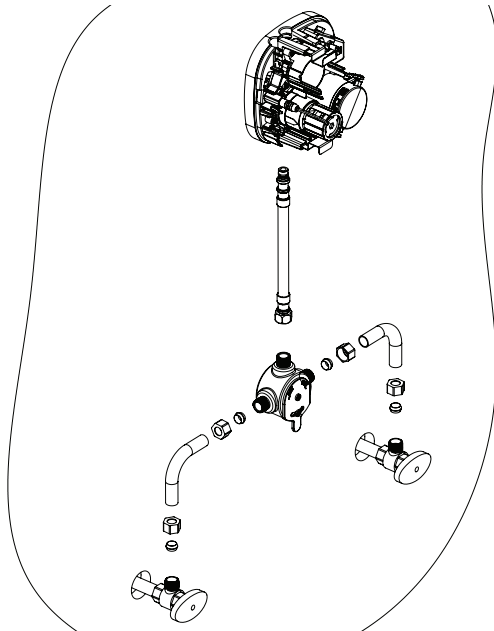

- D** Secure flex hoses to the control module by opening supply hose stainless steel clips.

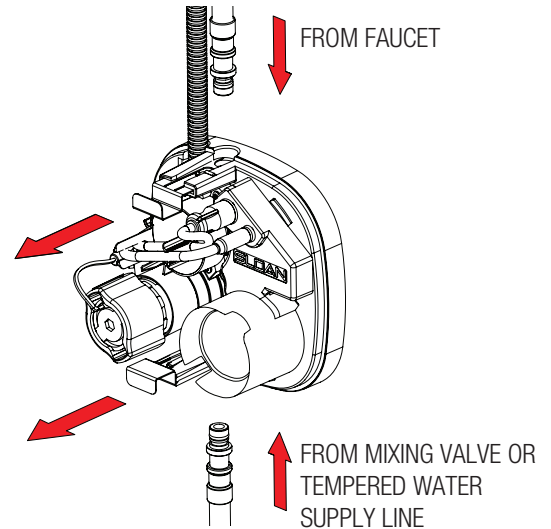

- E** Close supply hose stainless steel clips. **NOTE: NEVER OPEN STAINLESS STEEL CLIPS WHEN WATER SUPPLY IS TURNED ON.**

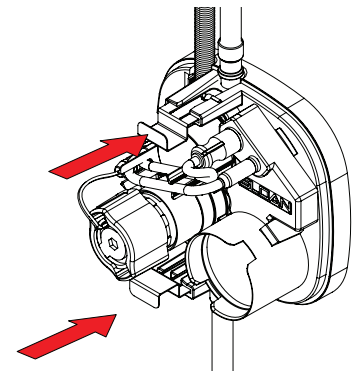

- F** Insert battery assembly.

- G** Turn on water.

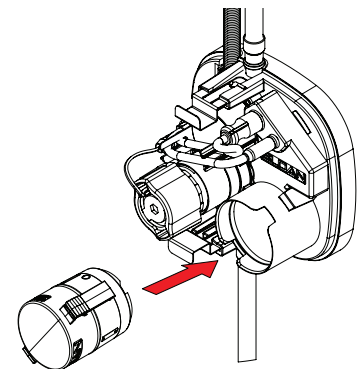

3 - ACTIVATION AND OPERATION OF FAUCET

A continuous ambient field is emitted and monitored by the faucet system. As the user's hands enter the effective range the sensor activates the solenoid valve allowing tempered water to flow from the faucet. Water will flow until the hands are removed or until the faucet reaches its automatic time out setting. When hands are moved away from the faucet, the capacitance sensor deactivates the solenoid valve, shutting off the water flow. The system automatically resets and is ready for the next user.

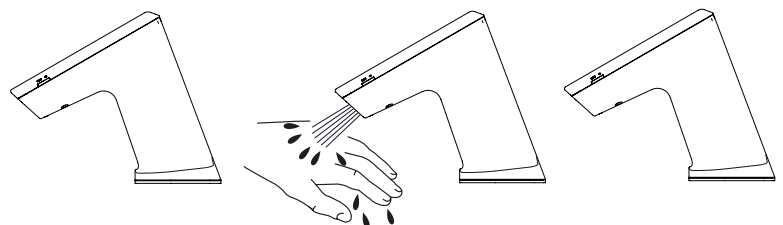

4 - BATTERY REPLACEMENT

NOTE: REPLACE BATTERY WHEN RED BATTERY INDICATOR LED FLASHES 4 TIMES EACH TIME FAUCET IS IN USE OR WHEN FAUCET STOPS FUNCTIONING.

A No need to turn off water.

B Loosen screw with hex wrench and remove cover.
NOTE: IT IS POSSIBLE FOR THE FAUCET TO ACTIVATE WHEN THE CAP WIRE OR SOLENOID IS TOUCHED OR WHEN THE CONTROL MODULE COVER IS BEING SCREWED ONTO THE MANIFOLD.

C Slide cover forward and lift off.

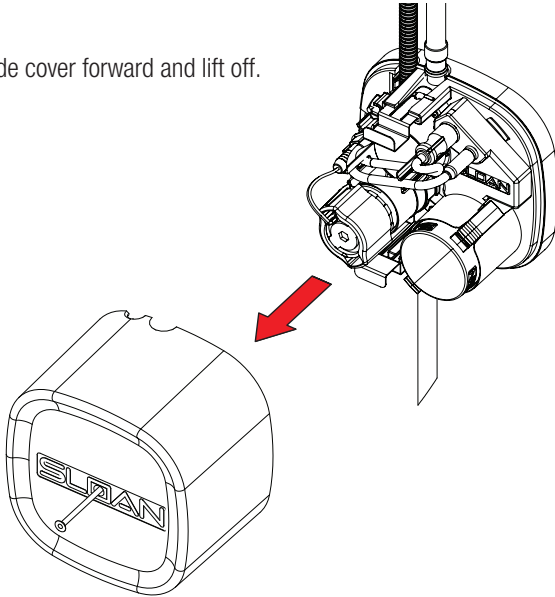

D Remove battery case.

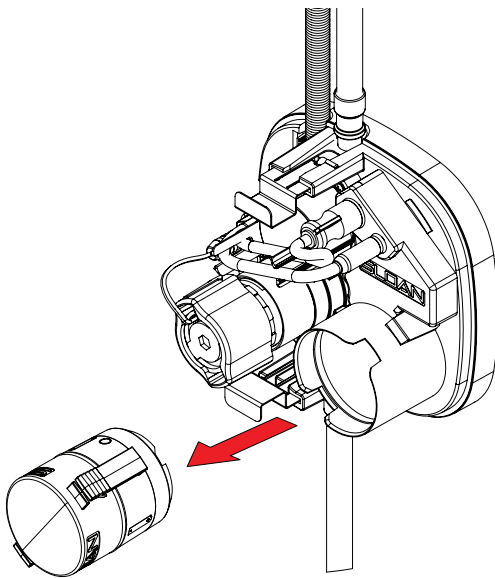

E Twist top of battery pack counter-clockwise to open. Remove batteries and replace batteries with four (4) new "AA" batteries. Twist top of battery pack clockwise to close.

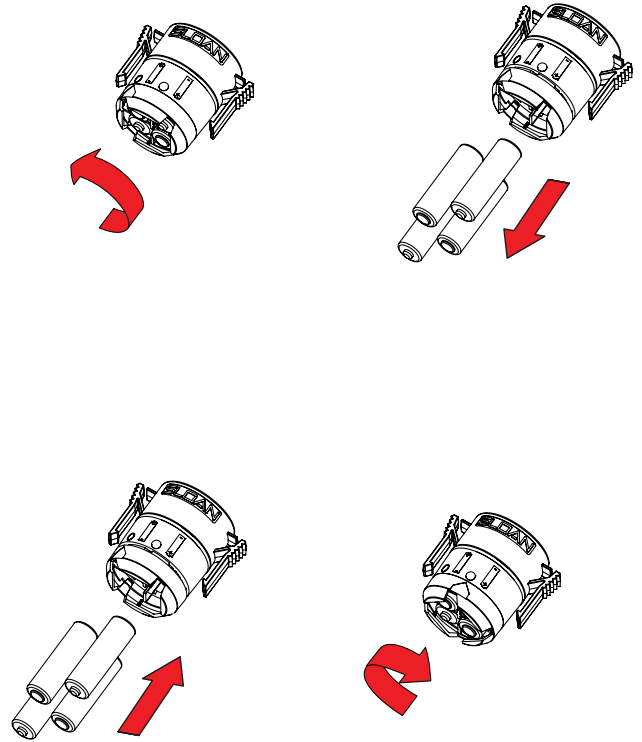

F Replace cover.

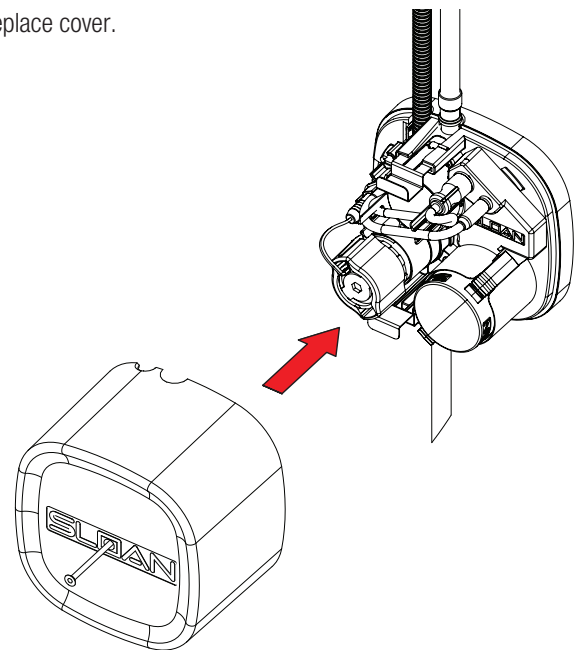

REPLACE FILTER

- A** Disconnect solenoid wire from control module.

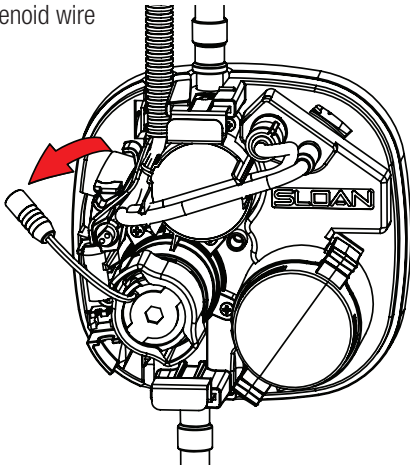

- B** Turn solenoid caddy counterclockwise lining up arrows on control module and solenoid caddy assembly.

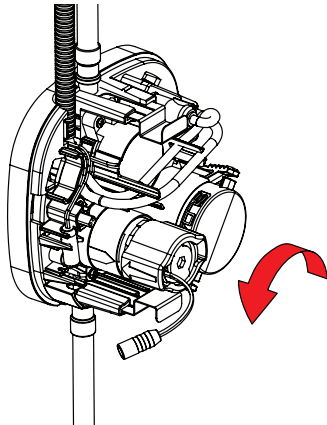

- C** Remove solenoid caddy assembly from control module by pulling straight out.

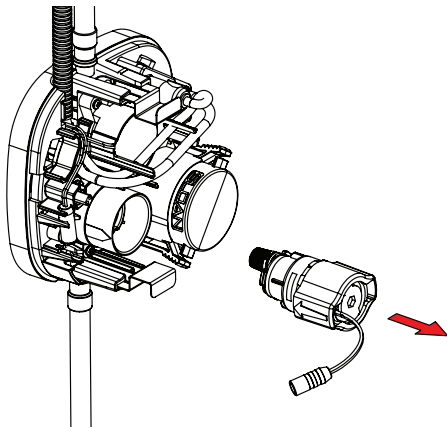

- D** Remove filter from solenoid caddy assembly.

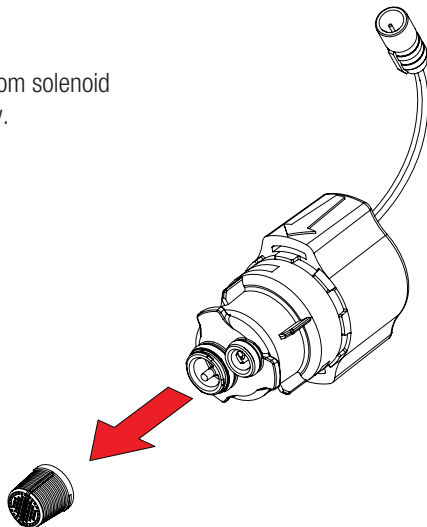

- E** Remove new filter from control module cover.

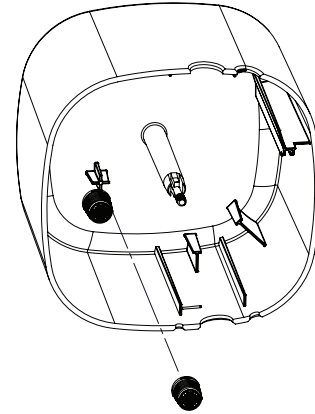

- F** Snap new filter onto solenoid caddy assembly.

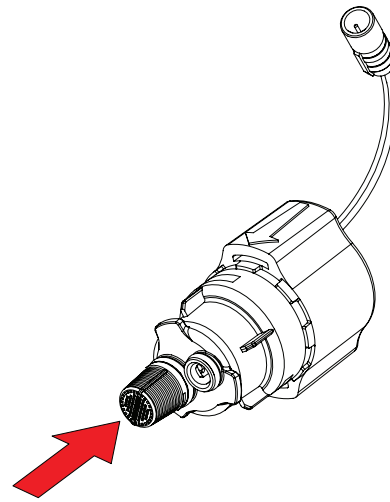

- G** Insert solenoid caddy assembly into control module lining up arrows. Turn solenoid caddy assembly clockwise 45°. Reconnect solenoid caddy wire to control module.

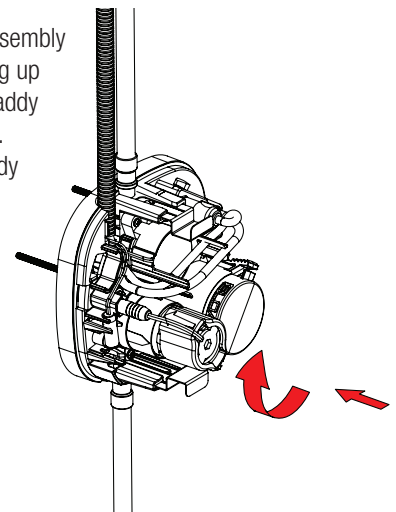

TROUBLESHOOTING

1. **Green LED in spout does not blink 2 seconds after battery installation.**
Battery placement incorrect or batteries have been discharged.
 Ensure alkaline batteries are installed properly. Check the orientation of each battery matches the positive (+) and negative (-) symbols shown on the battery compartment.
2. **Faucet does not function.**
 Capacitance cable not connected. Connect cable.
3. **Faucet delivers water in an uncontrolled manner.**
Faucet is not working properly.
 Clean sensor window; if problem persists contact Sloan Tech Support (see below).
4. **Faucet does not deliver any water when sensor is activated.**
Solenoid valve produces an audible “CLICK”.
A. Water supply stop(s) closed.
 Open water supply stop(s).
B. Strainer is clogged.
 Remove, clean, and reinstall strainer. Replace strainer (filter), if needed (refer to page 6)
Solenoid valve DOES NOT produce an audible “CLICK”.
A. Batteries low (battery powered models).
 Replace batteries (refer to battery replacement on page 5).
B. Power failure (hardwire models).
 Check power supply.
5. **Faucet delivers only a slow flow or dribble when sensor is activated.**
Water supply stop(s) are partially closed.
 Completely open water supply stop(s).
6. **Faucet does not stop delivering water or continues to drip after user is no longer detected.**
Faucet is not working properly.
 Clean sensor window; if problem persists contact Sloan Tech Support (see below).
7. **LED indicator blinks RED when faucet is in use.**
Batteries low (battery powered models).
 Replace batteries (refer to battery replacement on page 5).
8. **The water temperature is too hot or too cold on a faucet connected to hot and cold water supply lines.**
A. Supply stops are not adjusted properly.
 Adjust supply stops.
B. For models with integral side mixing valve—Mixing valve is set improperly for the water temperature desired.
 Rotate mixing valve handle clockwise to decrease water temperature or counterclockwise to increase water temperature.
C. Inadequate hot water supply.
 Adjust supply stops.

LED DISPLAY DIAGNOSTIC CODES

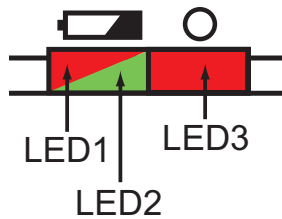

NOTE: LED1 (RED) and LED2 (GREEN) are for battery and programming related items. LED3 (RED) is for solenoid service.

Function	LED1	LED2	LED3	Notes
Power Up Success (Battery Only Models)		Blinks 5x		Blinks 1 every second (5 seconds); for battery power
Power Up Success (Adapter Models)	Blinks 3-5x	Blinks 3-5x		Blinks 1 every second (3-5 seconds); for adapter power
Low Battery	Blinks 4x			Battery power is low; During hand detection
Clean Mode		Blinks		Once every 2 seconds; Touch faucet body more than 8 seconds, water hold for 2 minutes
Water Hold		Blinks		Once every 1 second; If water turns on/off 5 times in 20 seconds, faucet turns off for 1 minute
Solenoid Latch Failure			Blinks	Two RED LED blinks; After hand removed from detection zone
Cap Sensor Fails to Calibrate		Blinks		4 times per second; Before first water burst Detection for cable is not installed correctly
Ambient Electrical Noise Too High		Blinks		4 times per seconds; After first water burst

CARE AND CLEANING

DO NOT USE abrasive or chemical cleaners (including chlorine bleach) to clean faucets that may dull the luster and attack the chrome or special decorative finishes. Use **ONLY** mild soap and water, then wipe dry with clean cloth or towel. While cleaning the bathroom sink, protect the faucet from any splattering of cleaner. Acids and cleaning fluids will discolor or remove chrome plating.

PARTS LIST

Item No.	Part No.	Description
1	EFX-2	Bowed Crown
2	EFX-36	Control Module Mounting Kit
3	EFX-8-A	Battery Pack Assembly
4	EFX-13-A	Solenoid Valve Caddy 0.5 gpm (1.9 Lpm)
	EFX-14-A	Solenoid Valve Caddy 1.5 gpm (5.7 Lpm)
5	EFX-19	Filter / Strainers
6	EFX-1003-A	Control Module Assembly – 0.5 gpm (1.9 Lpm)
	EFX-1004-A	Control Module Assembly with Turbine – 0.5 gpm (1.9 Lpm)
	EFX-1005-A	Control Module Assembly – 1.5 gpm (5.7 Lpm)
	EFX-1006-A	Control Module Assembly with Turbine – 1.5 gpm (5.7 Lpm)
7	EFX-31	120 VAC/6.75 VDC Plug-in Voltage Adapter
8A	EAF-1	Faucet Spout Mounting Kit (Pedestal)
8B	EFX-21-A	Faucet Spout Mounting Kit (Integrated Base)
9	EFX-20-A	Base Plate for 4" Centerset Sink
10	EFX-26-A	Base Plate for 8" Centerset Sink
11	MIX-60-A	Below Deck Mechanical Mixing Valve
12	MIX-135-A	Below Deck Thermostatic Mixing Valve
13	ETF-617-A	Bak-Chek® Tee
14	EFX-33	Inlet Hose Fitting
15	EFX-34	Flexible Supply Hose 18" (45 mm)
16	EFX-1002-A	0.5 gpm (1.9 Lpm) Multi-Lam Spray Insert (includes: insert, o-ring, removal tool, and 2.5 mm allen key)
	EFX-1001-A	1.5 gpm (5.7 Lpm) Aerated Stream Insert (includes: insert, o-ring, removal tool, and 2.5 mm allen key)
	EFX-1000-A	1.5 gpm (5.7 Lpm) Laminar Stream Insert (includes: insert, o-ring, removal tool, and 2.5 mm allen key)
17	EAF-23-A	Splitter
18	EFX-24-A	11-13/16" (300 mm) Extension Cable
	EFX-25-A	47-1/4" (1200 mm) Extension Cable
	EFX-17-A	126" (3200 mm) Extension Cable

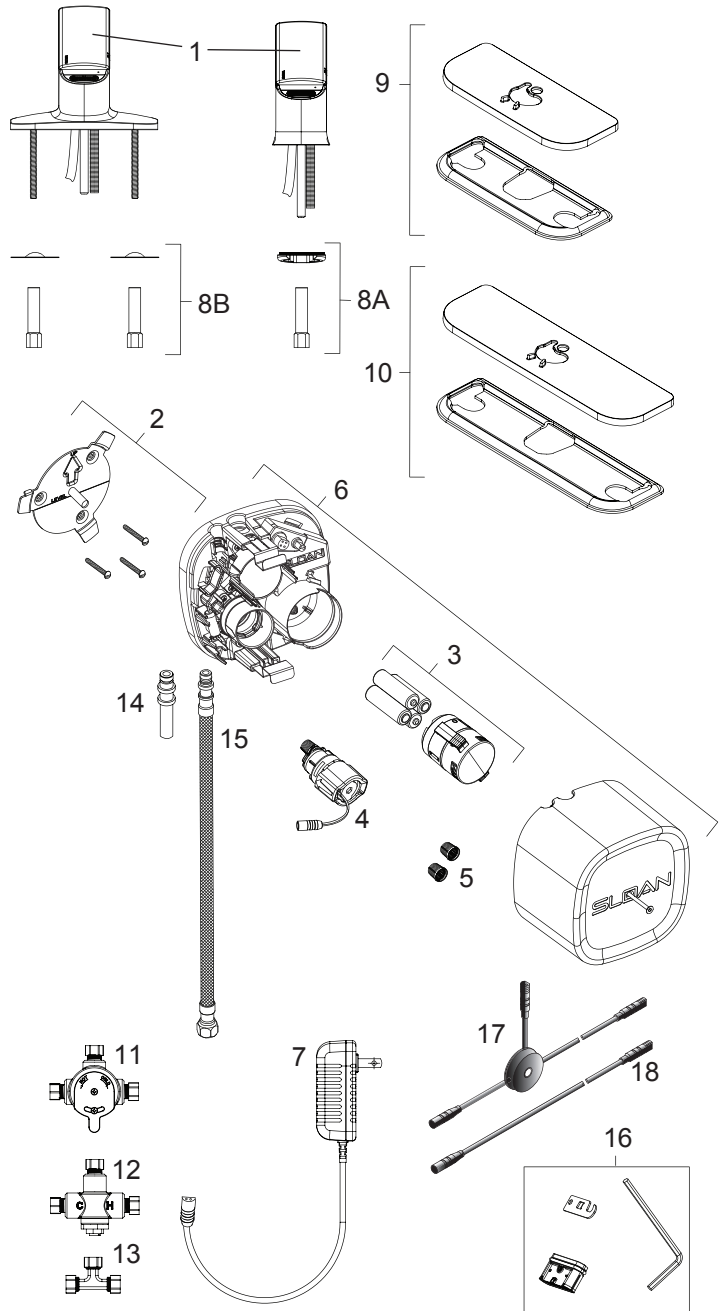

NOTE: If changing flow rate, caddy and spray insert must be changed in conjunction.

Manufactured by Sloan Valve Company under one or more of the following U.S. Patents: 7,690, 623; 7,069,941; 6,619,320.

The information contained in this document is subject to change without notice.

SLOAN • 10500 SEYMOUR AVENUE • FRANKLIN PARK, IL 60133

Phone: 1-800-9-VALVE-9 (1-800-982-5839) • Fax: 1-800-447-8329 • www.sloan.com