



## PRIOR TO INSTALLATION

Prior to installing the Sloan BASYS™ Series Faucets, install the items listed below. Also, refer to rough-in illustrations.

### IMPORTANT:

- ALL PLUMBING SHOULD BE INSTALLED IN ACCORDANCE WITH APPLICABLE CODES AND REGULATIONS.
- FLUSH ALL WATER LINES PRIOR TO MAKING CONNECTIONS.
- KEEP THREAD SEALANT OUT OF YOUR WATERWAY TO PREVENT COMPONENT PART DAMAGE! DO NOT USE ANY SEALANT ON COMPRESSION FITTINGS.

### Base Plates

When the BASYS™ Faucet is installed on a sink that has three (3) hole punchings, a base plate should be used. **Base Plates should be specified at the time of ordering.**

EFX-20-A – 4" (102 mm) Centerset Sinks

EFX-26-A – 8" (203 mm) Centerset Sinks

## TOOLS REQUIRED FOR INSTALLATION

- 13 mm open end wrench or nut driver for faucet retainer nut
- 2.5 mm hex allen wrench
- 5/8" open end wrench for female end of flex hose

## FAUCET ROUGH-IN

**EFX-3X0.X0X.0000**  
with Tempered Water Supply†

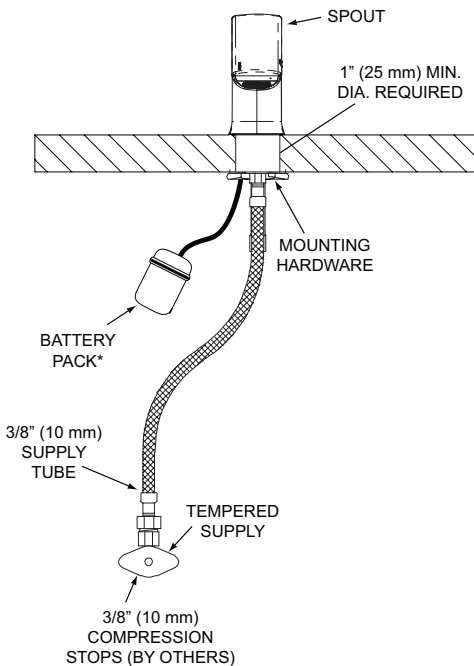

**EFX-3X0.X0X.0100**  
with Hot/Cold Water Supply†  
and 4-inch Base Plate

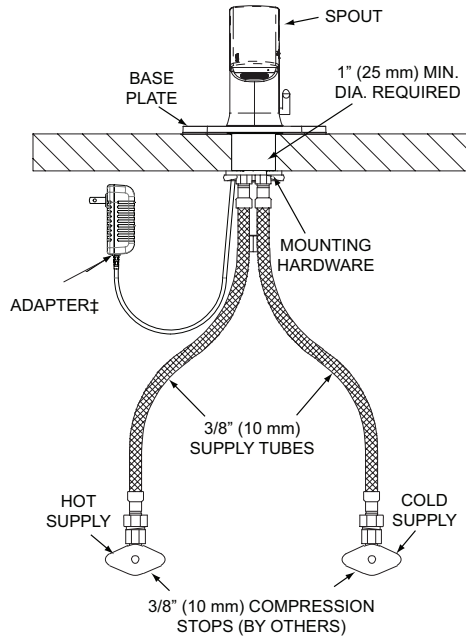

**EFX-6X0.X0X.0000**  
with Hot/Cold Water Supply†

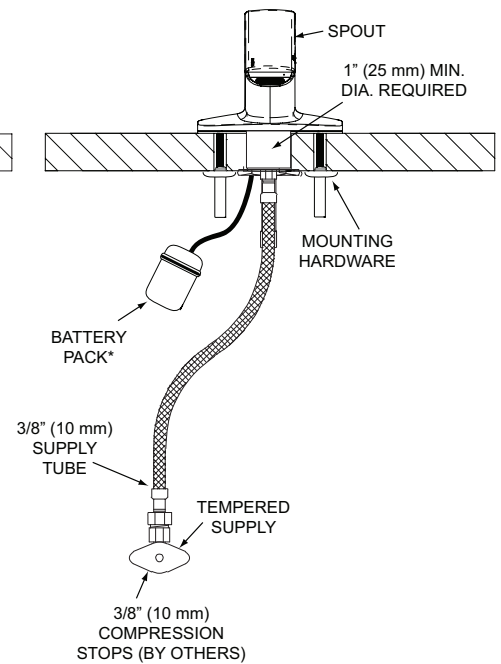

† EFX Faucets are available with a 0.5 gpm (1.9 Lpm) multi-laminar spray, 1.5 gpm (5.7 Lpm) aerated stream, and 1.5 gpm (5.7 Lpm) laminar stream.

\* One faucet per battery pack.

‡ No battery backup on hardwire low pedestal/low integrated base models.

# FAUCET ROUGH-IN

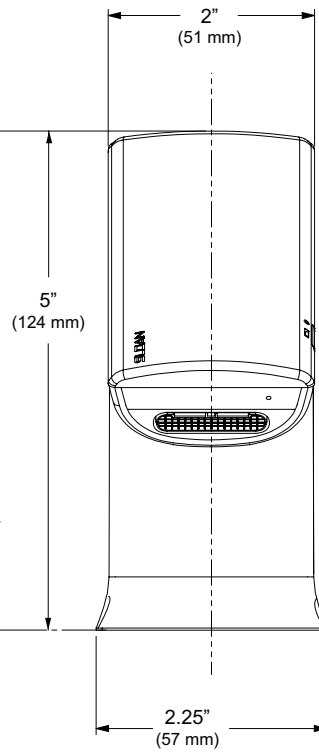
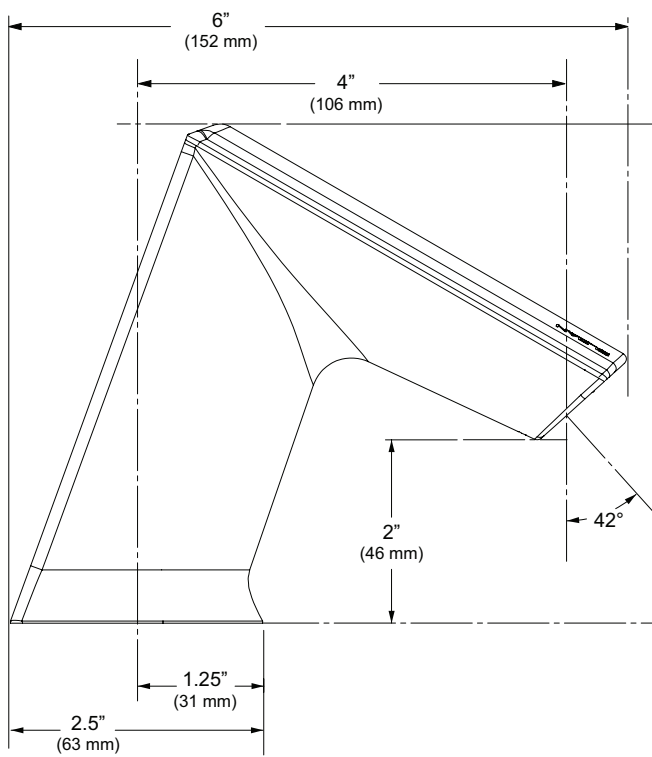
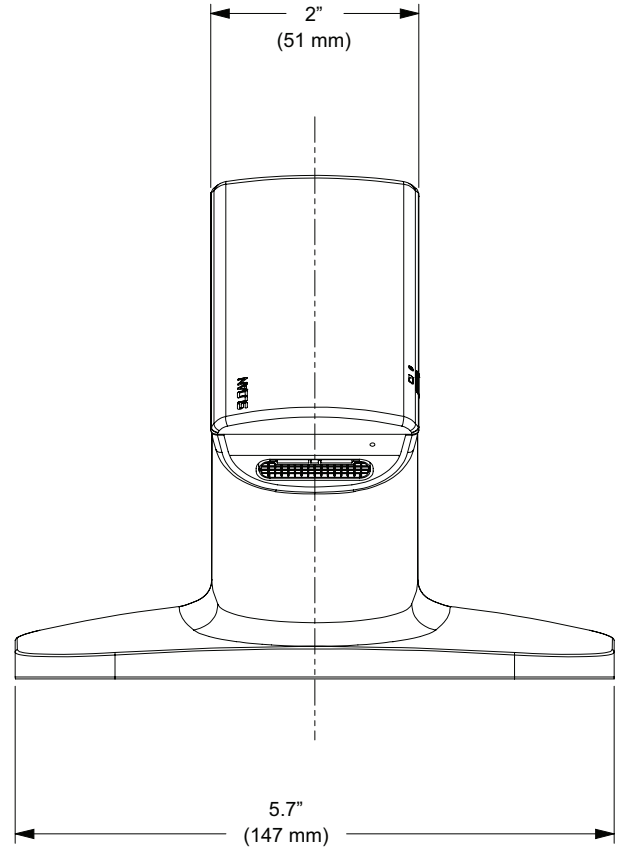
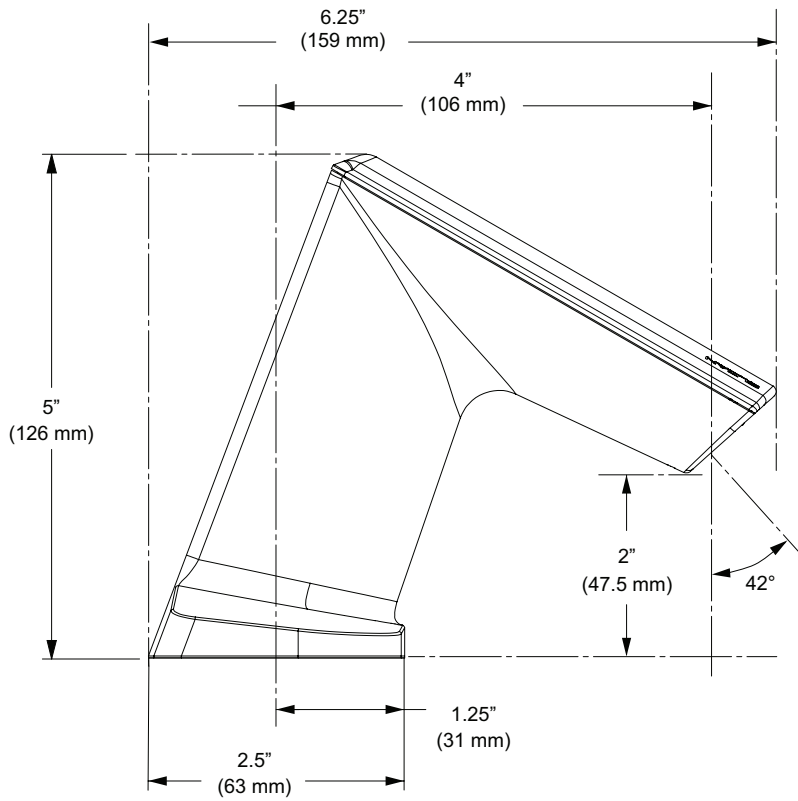

## 1 - INSTALL FAUCET

- A** Remove nut, faucet retainer and gasket.
- B** Install Faucet with faucet retainer into the center hole in deck or lavatory — **1-3/16" (30 mm) min. hole required.**

**NOTE: If installing the Faucet on a three (3) hole sink, a Base Plate should be installed at this time.**

**NOTE: Do not remove label until water is connected.**

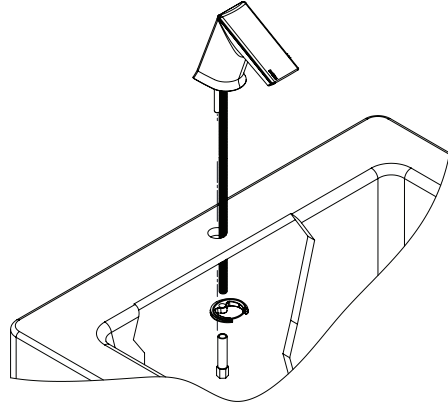

## 2 - SECURE TO SINK DECK

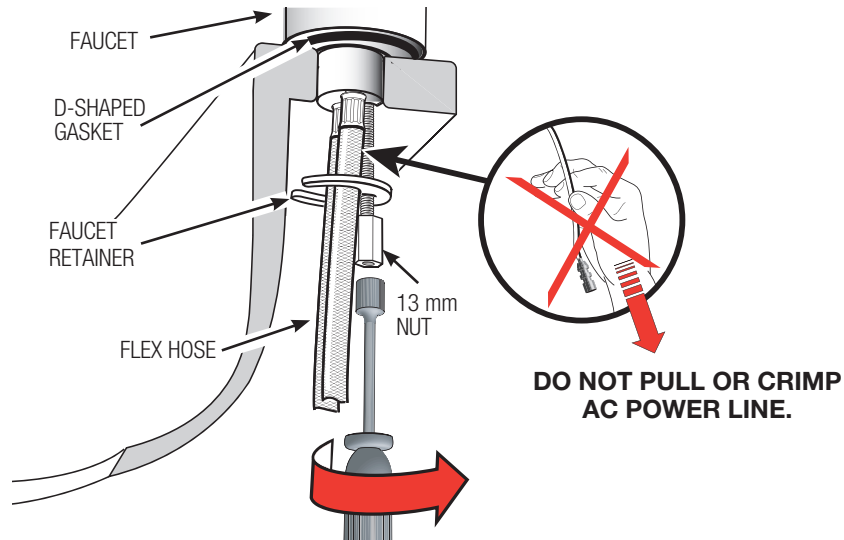

## 3 - CONNECT TO WATER SUPPLY

- A** **IMPORTANT: FLUSH DIRT, DEBRIS, AND SEDIMENT FROM SUPPLY LINE(S) BEFORE CONNECTING FLEX HOSES.**

- B** Install flex hose(s) with gaskets onto supply stops.

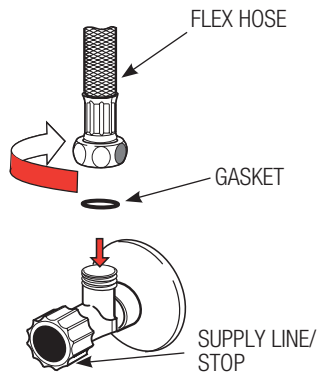

- C** Tighten the flex hose(s) (with gaskets in place) secure to the supply.

- D** **For single supply faucets** – Install flex hose with gasket onto mixing valve and connect check tee or mixing valve to hot and cold water supplies.

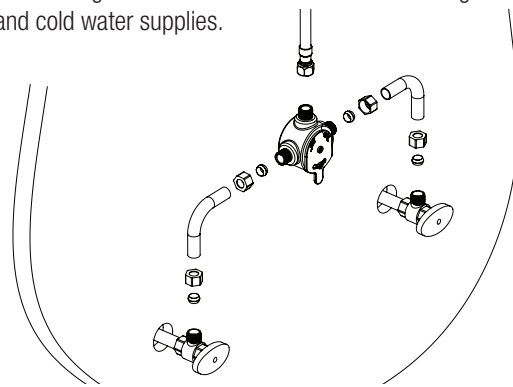

- E** Open supply stop(s).

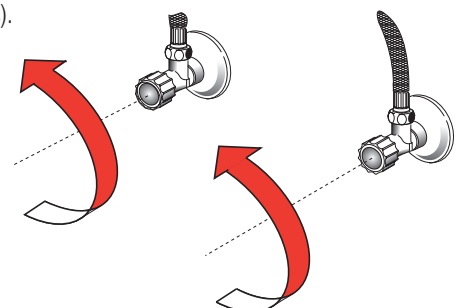

## 4 - START-UP SEQUENCE

- A** For Hardwire Models, Plug Adapter into receptacle.

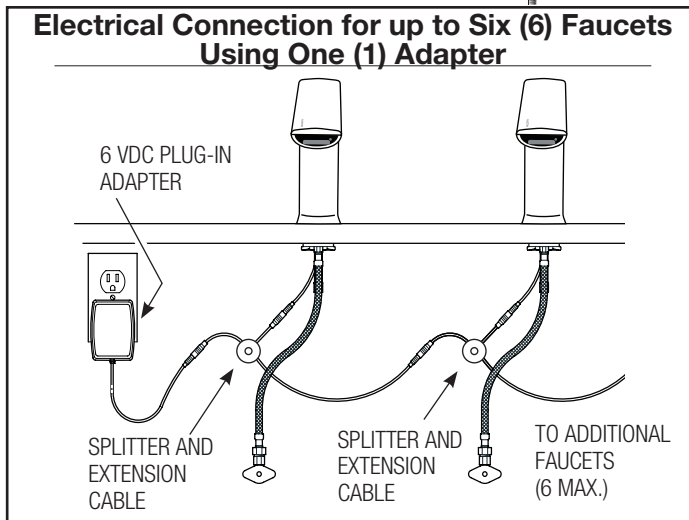
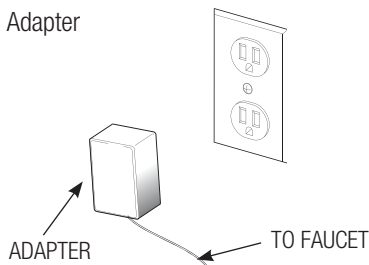

- B** Remove label from sensor window.

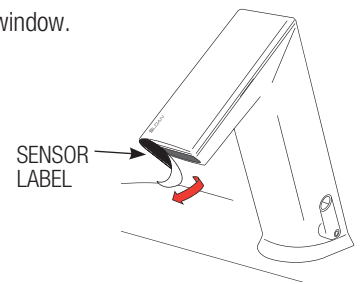

- C** Activate faucet by holding installation instructions approximately 1-1/2" (38 mm) in front of sensor window until Red LED turns on then remove instructions while faucet sense its surroundings. Wait for green LED on side of faucet.

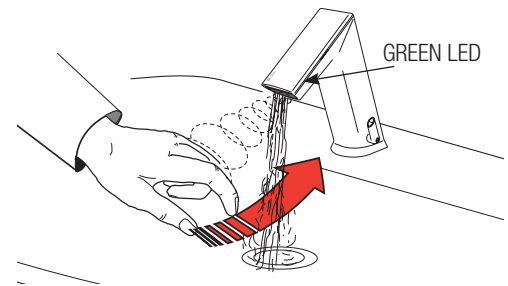

- D** Activate faucet and check for leaks. If faucet does not function, refer to the troubleshooting section.

## 5 - SET AND FIX TEMPERATURE AND ADJUST HOT LIMIT STOP (FOR LOW PEDESTAL MODELS ONLY)

- A** Adjust lever to set temperature.

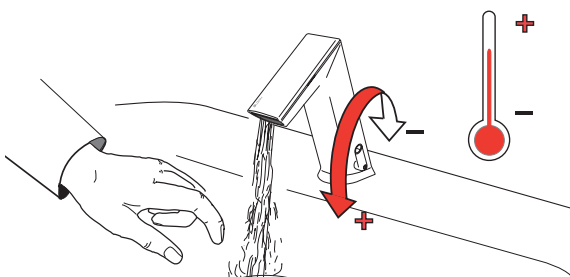

- B** **OPTIONAL** – To fix temperature, set lever to the desired position, then remove lever and plug hole with cap.

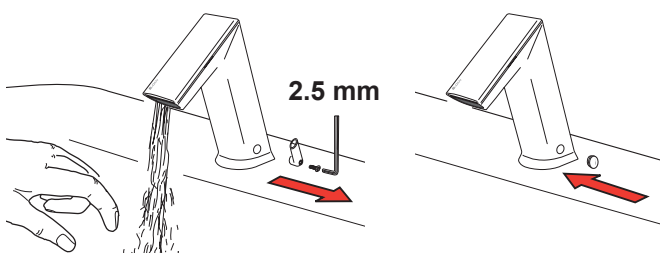

- C** **Optional Hot Limit Stop Adjustment** – To adjust the hot/cold mix (factory set at 50/50) remove the lever. Check to make sure dot is in center position before beginning adjustment.

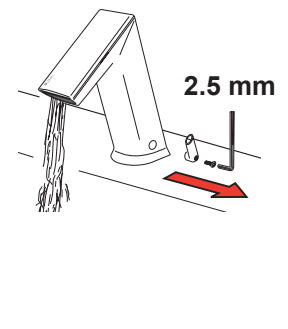

Faucet may be adjusted in 10° increments.

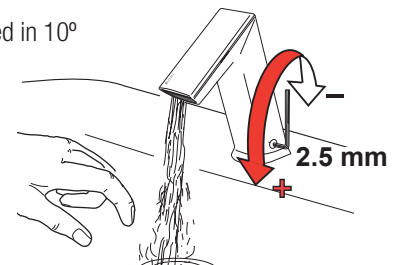

## ADDITIONAL FUNCTIONS

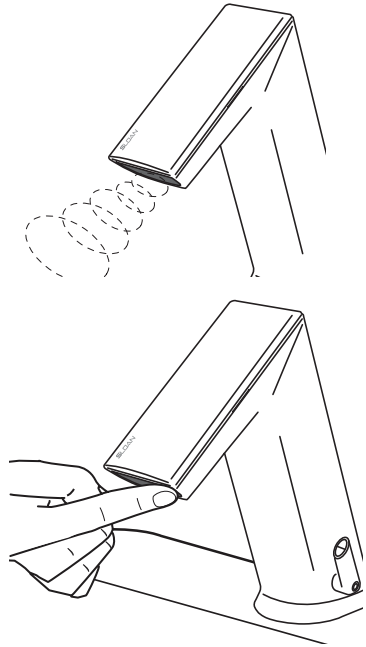

Function	Steps to Activate Function	Default Setting	IR Clic
<b>IR Activation</b>	Cover IR clic approximately for 2 sec. until LED will flash GREEN 1x - then remove finger from IR clic (Active for 5 sec.)	—	—
<b>Cleaning Mode</b>	IR Activation; Cover IR clic 2x - confirmation of the function is active by a couple flashes by the LED; to return to normal operation cover IR clic 1x or the faucet will automatically return to normal function after 2 min.	2 min.	—
<b>12/24 Line Purge Feature</b>	See below.	Off	Off 12HR 24HR
<b>Sensor Range Adjustment</b>	See page 7.	6	1-8
<b>Reset Electronics</b>	IR Activation Cover IR clic 2x; LED will flash 5x Cover IR clic 1x for 5 sec. until LED flashes 4x, then remove finger from IR clic Wait for 20 sec. (After 10 sec. water will flow for 6 sec. and automatically adjust to environment)	Manually	—
<b>Security Off</b>	After 90 seconds (max) of hand and/or object within sensor appears permanent, waterflow will stop and will remeasure environment	On	—

Please contact factory for more extensive programming options.

## 12/24 LINE PURGE FEATURE

This feature will operate the faucet every 12 or 24 hours since last use, if not used to prevent stagnant water conditions.

Default purge duration is two minutes.

Consult factory regarding other timing options.

- A** IR activation (see above). Cover IR clic approximately 24 sec. (ignore LED indications during this period). Release when requested program is reached. (See diagram to right). Programming mode will time out after 2 minutes if no changes are made.

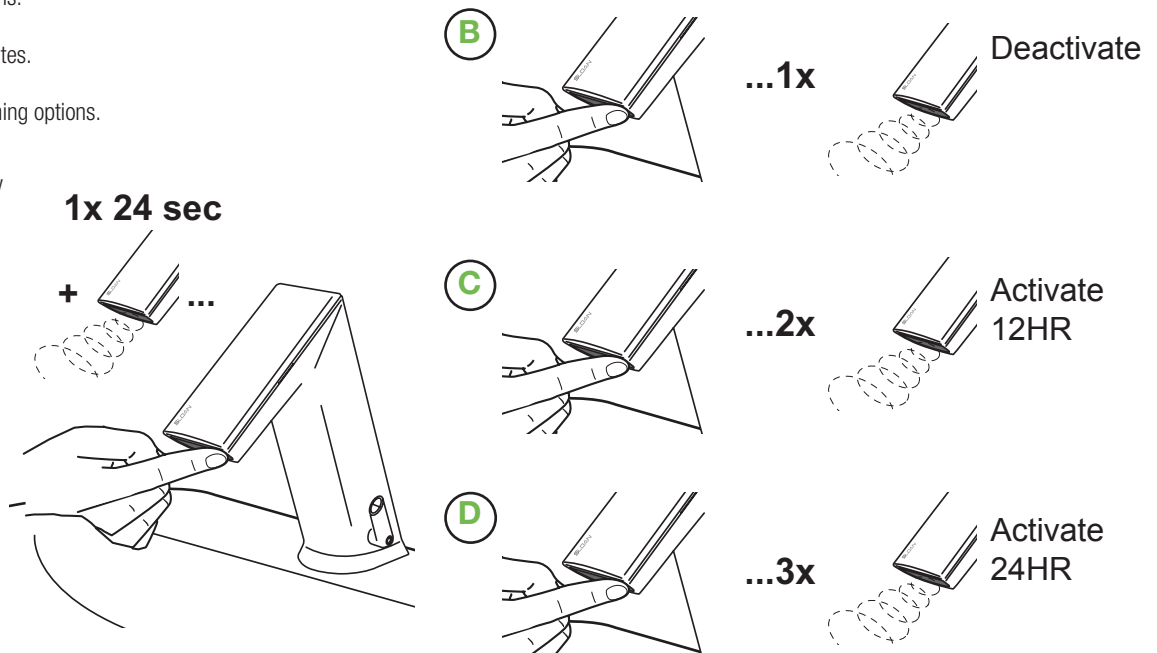

## SENSOR RANGE ADJUSTMENT

**FACTORY SETTING IS APPROPRIATE FOR THE MAJORITY OF APPLICATIONS AND SHOULD NOT REQUIRE RESETTING UNLESS UNDER EXTREME SITUATIONS: HIGH REFLECTION OR LOW LIGHT.**

**A** IR Activation (see page 5). To enter programming mode place finger on IR clic for 2 times then remove. Light on side of crown should blink to indicate programming mode.

**B** Cover IR clic until LED flashes Red 4 times-hold IR Clic until LED flashes 1 time to 8 times from minimum to maximum range. See diagram below. Release when requested range is reached.

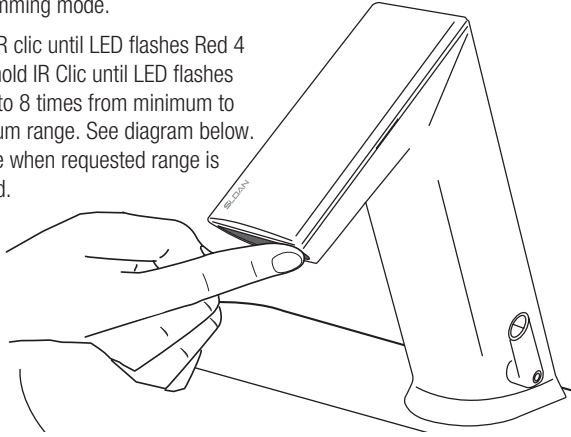

**6x - Factory Setting**

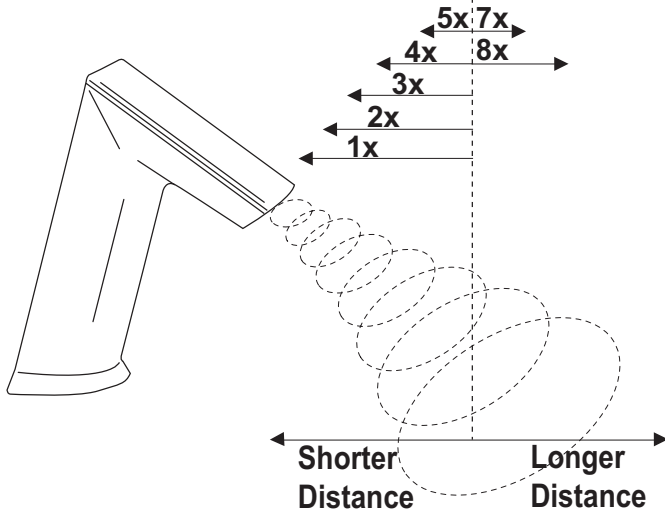

**C**

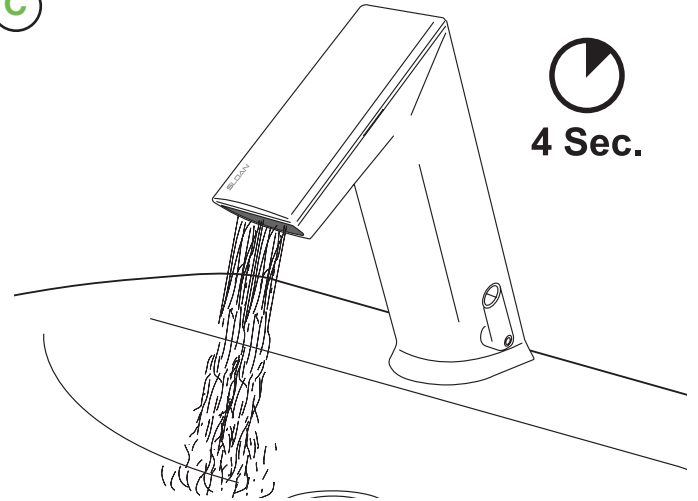

**D**

Wait, until LED flashes GREEN.

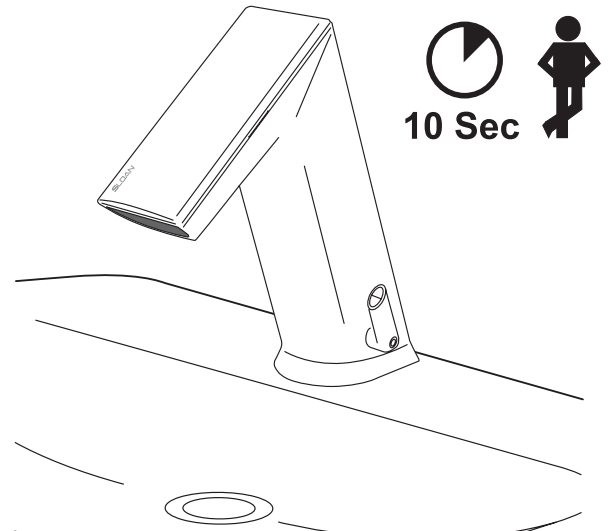

## BATTERY REPLACEMENT

**NOTE:** Replace Battery when LED1 indicator flashes red each time faucet is in use or when faucet stops functioning. LED1 is identified by the battery symbol.

**NOTE:** Turning off water is not necessary.

- A** Loosen cover screw and remove cover from battery pack.
- B** Install four (4) AA-size batteries (supplied) as indicated by the (+) and (-) symbols inside the battery compartment.
- C** Replace battery pack lid and tighten with screwdriver.  
**NOTE:** Insure batteries are installed with proper polarity. The cover of the case indicates polarity of batteries. Improper polarity will not harm the faucet. Improper polarity will cause the faucet not to operate.

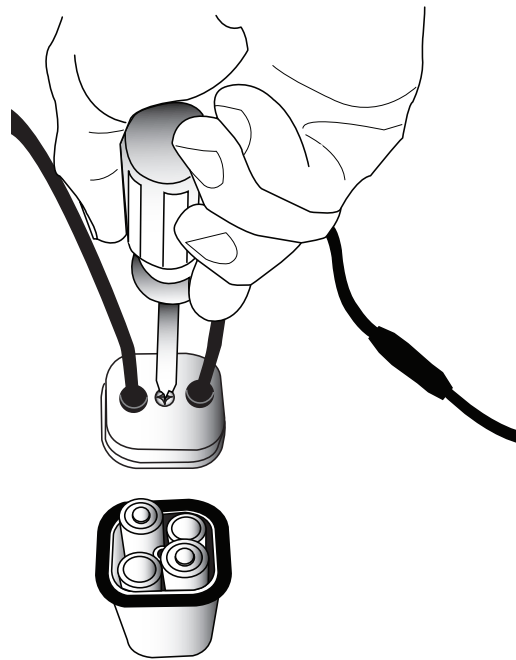

## REPLACING THE SOLENOID/FILTER

**NOTE:** TURNING OFF WATER IS NOT NECESSARY, DUE TO INTEGRATED AUTOMATIC STOP VALVE.

- A** Remove crown by loosening hex screw located on underside of spout and slide crown down and lift off.  
**NOTE:** Screw is captive within faucet body.

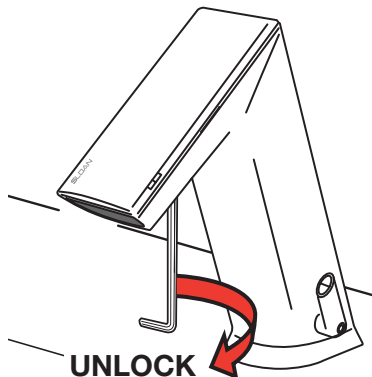

- B** Rotate solenoid assembly counter-clockwise through a 45° angle.

**SPARE FILTER**

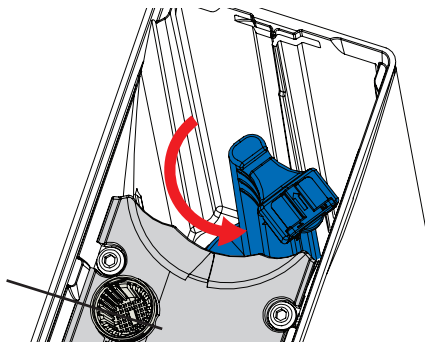

- C** Pull solenoid caddy from faucet.  
**NOTE:** Strainer can be removed, cleaned and replaced at this time.

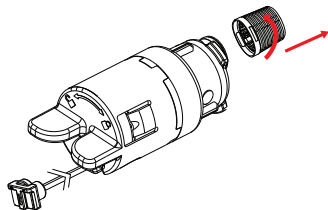

- D** Insert new solenoid caddy at a 45° angle.

- E** Rotate solenoid caddy clockwise to align with arrow, locking the unit and opening water path.

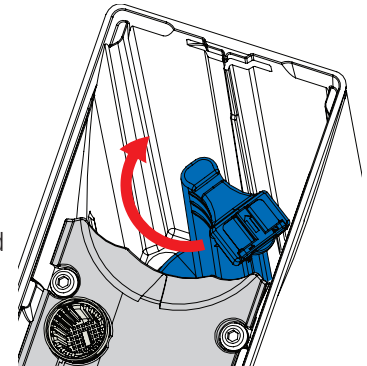

- F** Slide on crown and secure.

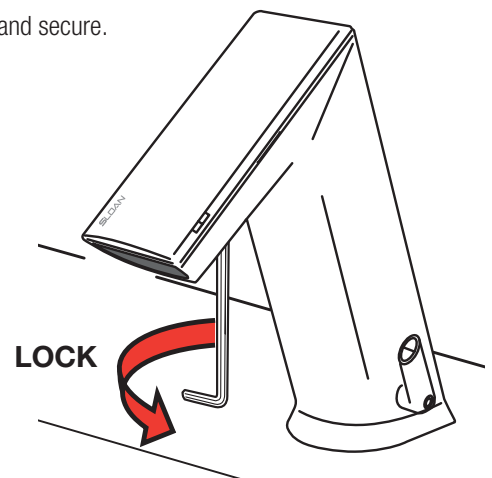

## REPLACE SPRAY INSERT

**NOTE: TURNING OFF WATER IS NOT NECESSARY, DUE TO INTEGRATED AUTOMATIC STOP VALVE.**

- A** Remove crown by loosening hex screw located on underside of spout and slide crown down and lift off.  
**NOTE: Screw is captive within faucet body.**

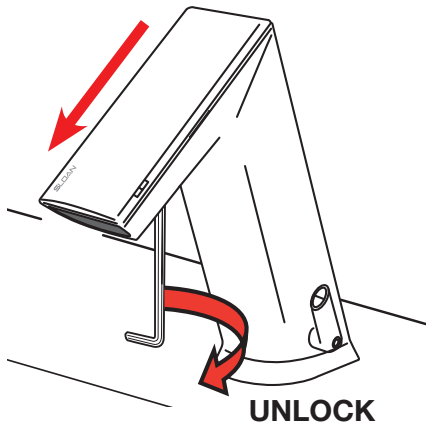

- B** Retrieve spray removal tool located near the spray insert.

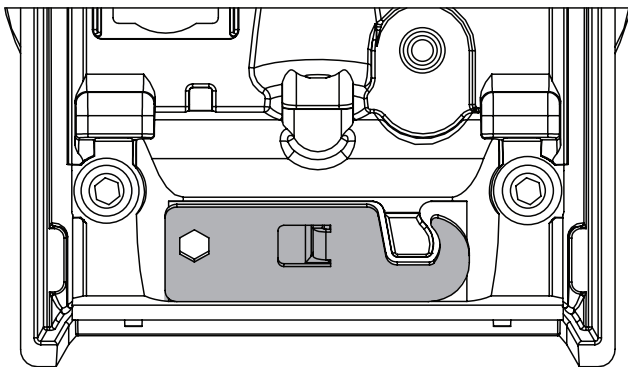

- C** Insert spray removal tool into spray slot by sliding hook end of key between faucet spout and insert. Pull insert out of faucet once hooked.

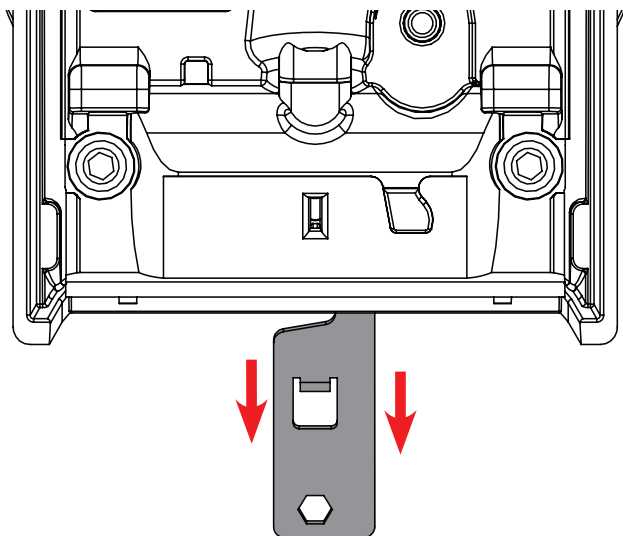

- D** Install new insert.  
**NOTE: If changing to a different flow rate solenoid caddy must also be changed.**

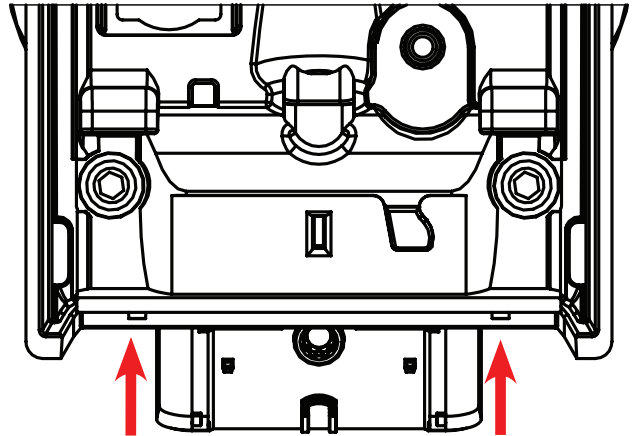

- E** Return spray removal tool to storage location.  
**NOTE: This can only be done once spray head is installed. This will lock the spray head in place.**  
**NOTE: If spray head is inserted incorrectly – key will not lock in properly. Turn faucet on to push insert out and re-install.**

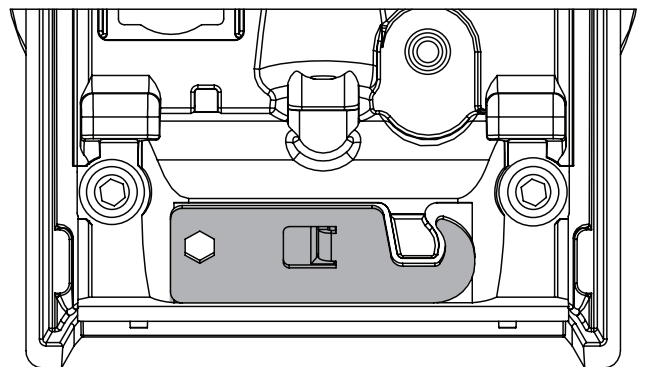

- G** Slide on crown and secure.

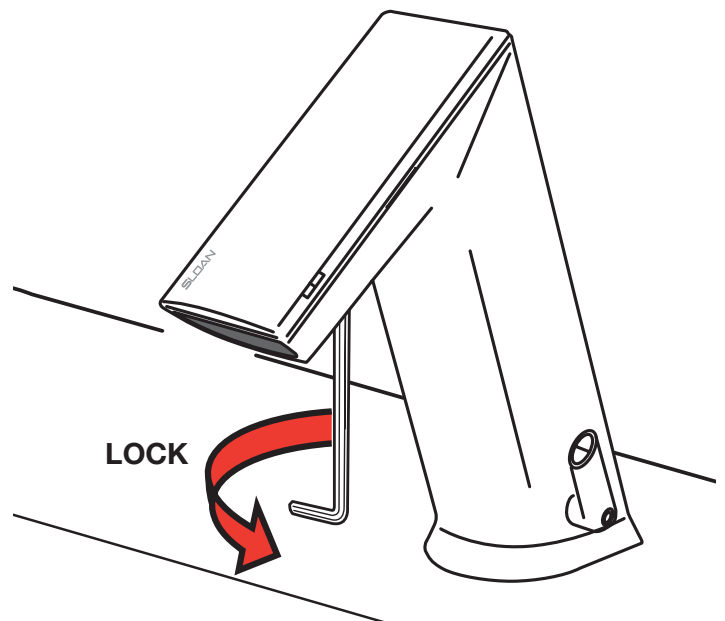

## UPGRADE FAUCET FUNCTIONALITY

- A** Remove crown by loosening hex screw located on underside of spout and slide crown down and lift off.

**NOTE: Screw is captive within faucet body.**

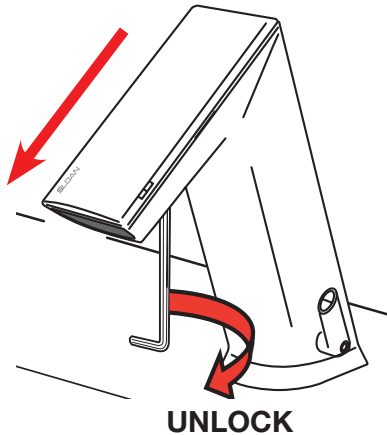

- B** Place new crown on faucet by sliding onto spout and tightening hex screw on underside of spout.

**NOTE: All electronics are fully encapsulated in the crown and thus protected from the environment and easy to replace or upgrade.**

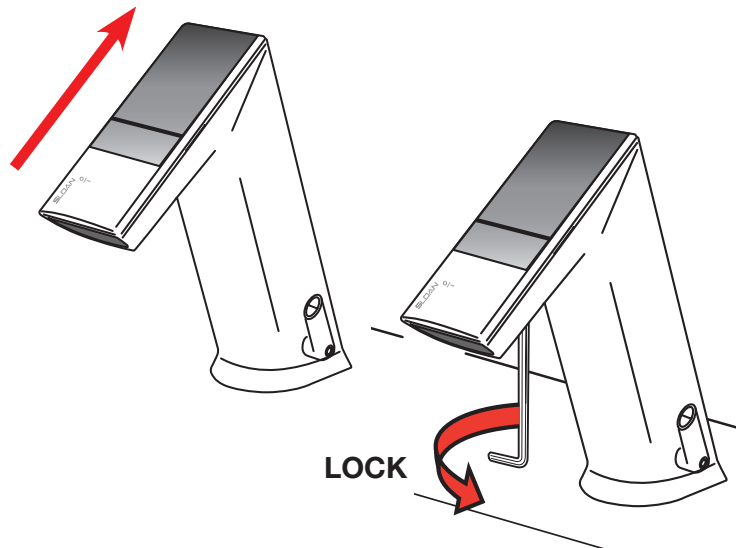

## LED DISPLAY DIAGNOSTIC CODES

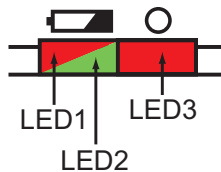

Function	LED1	LED2	LED3	Description 1	Description 2
Start Up Boot				LED1 and LED2 alternate blinking	Fast Toggle
Battery Check after Start Up				LED1 on for 2 sec, if battery greater than 3.5V	
Line Power Check after Start Up				LED3 on for 2 sec, if line power is greater than 3.5V	
IR Adjust Process				LED1 blinking while IR adjusts	Few seconds
IR Adjust OK				LED2 on for 2 sec, if adjustment OK	
Battery Low				LED1 blinks 3x, if battery is less than warning level	Only while in detection mode
Battery Empty				LED1 double flashes 3x, if battery is less than empty level	Only while in detection mode
Valve Error				LED3 double flashes 3x, if valve current error; flash after the 3rd error, off after the 3rd good operation	Flashes after the 3rd error, off after the 3rd good operation
IR Activation				LED2 on for 2 sec, if IR-click has been activated	After 5 sec. automatically back to operating mode
Cleaning Mode				LED1 4-in-1 flash, if cleaning mode is activated	During "Cleaning Mode" is activated Permanent 4-in-1 flashes

## TROUBLESHOOTING GUIDE

- 1. Red LED in spout does not blink 2 seconds after battery installation.**  
**Battery placement incorrect or batteries have been discharged.**  
Ensure alkaline batteries are installed properly. Check the orientation of each battery matches the positive (+) and negative (-) symbols shown on the battery compartment.
- 2. Faucet does not function.**  
**Adhesive packaging label affixed over sensor eye.**  
Remove adhesive label from sensor eye.
- 3. Faucet delivers water in an uncontrolled manner.**  
**Faucet is not working properly.**  
Clean sensor window; if problem persists contact Sloan Tech Support (see below).
- 4. Faucet does not deliver any water when sensor is activated.**  
**Solenoid valve produces an audible “CLICK”.**
  - A. Water supply stop(s) closed.**  
Open water supply stop(s).
  - B. Strainer is clogged.**  
Remove, clean, and reinstall strainer. Replace strainer (filter), if needed (refer to page 8)**Solenoid valve DOES NOT produce an audible “CLICK”.**
  - A. Batteries low (battery powered models).**  
Replace batteries (refer to battery replacement on page 7).
  - B. Power failure (hardwire models).**  
Check power supply.
- 5. Faucet delivers only a slow flow or dribble when sensor is activated.**  
**Water supply stop(s) are partially closed.**  
Completely open water supply stop(s).
- 6. Faucet does not stop delivering water or continues to drip after user is no longer detected.**  
**Faucet is not working properly.**  
Clean sensor window; if problem persists contact Sloan Tech Support (see below).
- 7. LED indicator blinks RED when faucet is in use.**  
**Batteries low (battery powered models).**  
Replace batteries (refer to battery replacement on page 7).
- 8. The water temperature is too hot or too cold on a faucet connected to hot and cold water supply lines.**
  - A. Supply stops are not adjusted properly.**  
Adjust supply stops.
  - B. For models with integral side mixing valve—Mixing valve is set improperly for the water temperature desired.**  
Rotate mixing valve handle clockwise to decrease water temperature or counterclockwise to increase water temperature.
  - C. Inadequate hot water supply.**  
Adjust supply stops.

When assistance is required, please contact Sloan Tech Support at:  
**1-888-SLOAN-14 (1-888-756-2614)**

## OPERATION

As the user's hands enter the beam's effective sensor range, the beam is reflected back into the sensor receiver and activates the solenoid valve allowing water to flow from the faucet. Water will flow until the hands are removed or until the faucet reaches its automatic time out limit setting, if hands remain in sensor range.

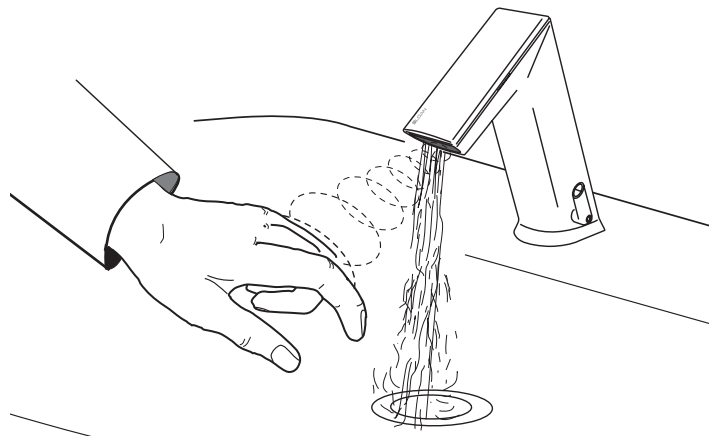

## CARE AND CLEANING

**DO NOT USE** abrasive or chemical cleaners (including chlorine bleach) to clean faucets that may dull the luster and attack the chrome or special decorative finishes. Use **ONLY** mild soap and water, then wipe dry with clean cloth or towel. While cleaning the bathroom sink, protect the faucet from any splattering of cleaner. Acids and cleaning fluids will discolor or remove chrome plating.

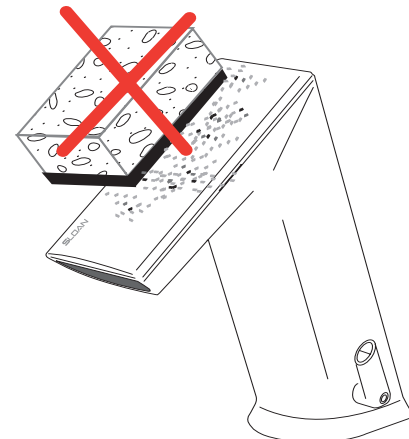

# PARTS LIST

Item #	Part #	Description
1A	–	Low Pedestal Faucet Assembly*
–	–	Low Pedestal Faucet Assembly with Mixer*
1B	–	Low Integrated Base Faucet Assembly†
2	EFX-1002-A	0.5 gpm/1.9 Lpm Multi-Lam insert (includes insert, o-ring, 2.5 mm allen key, and removal tool)
–	EFX-1001-A	1.5 gpm/5.7 Lpm Aerated Stream Insert (includes insert, o-ring, 2.5 mm allen key, and removal tool)
–	EFX-1000-A	1.5 gpm/5.7 Lpm Laminar Stream Insert (includes insert, o-ring, 2.5 mm allen key, and removal tool)
3A	EFX-37	0.5 gpm/1.9 Lpm Solenoid Valve Caddy Assembly – Low (Green)
3B	EFX-38	1.5 gpm/5.7 Lpm Solenoid Valve Caddy Assembly – Low (Blue)
4	EFX-19	Strainer (Filter)
5	EFX-23-A	Battery Pack Assembly
6A	EFX-1-A	Crown Assembly
6B	EFX-3-A	Solar Crown Assembly
6C	EFX-4-A	Solar Crown with LCD Assembly
7	EFX-24-A	Mixer Handle Assembly (for EFX-3 IR models only)
8	EFX-25	Handle Cap (for EFX-3 IR models only)
9A	EAF-1	Faucet Mounting Kit (for pedestal model only)
9B	EFX-21-A	Faucet Mounting Kit (for integrated base model only)
10	EAF-1008	13" (330 mm) Flexible Supply Hoses (2)
11	EFX-26-A	Base Plate for 8" Centerset Sink
12	EFX-20-A	Base Plate for 4" Centerset Sink
13	EAF-11	Plug-in Voltage Adapter (US)
–	EAF-41	Plug-in Voltage Adapter (EU)
–	EAF-39	Plug-in Voltage Adapter (UK)
–	EAF-37	Box Mount Adapter
14	EAF-24-A	11-13/16" (300 mm) Extension Cable
–	EAF-25-A	47-1/4" (1200 mm) Extension Cable
–	EAF-17-A	126" (3200 mm) Extension Cable
15	EAF-23-A	Splitter
16	MIX-60-A	Mechanical, Below Deck Mixing Valve
17	MIX-135-A	Thermostatic, Below Deck Mixing Valve
18	ETF-617-A	Bak-Chek Tee

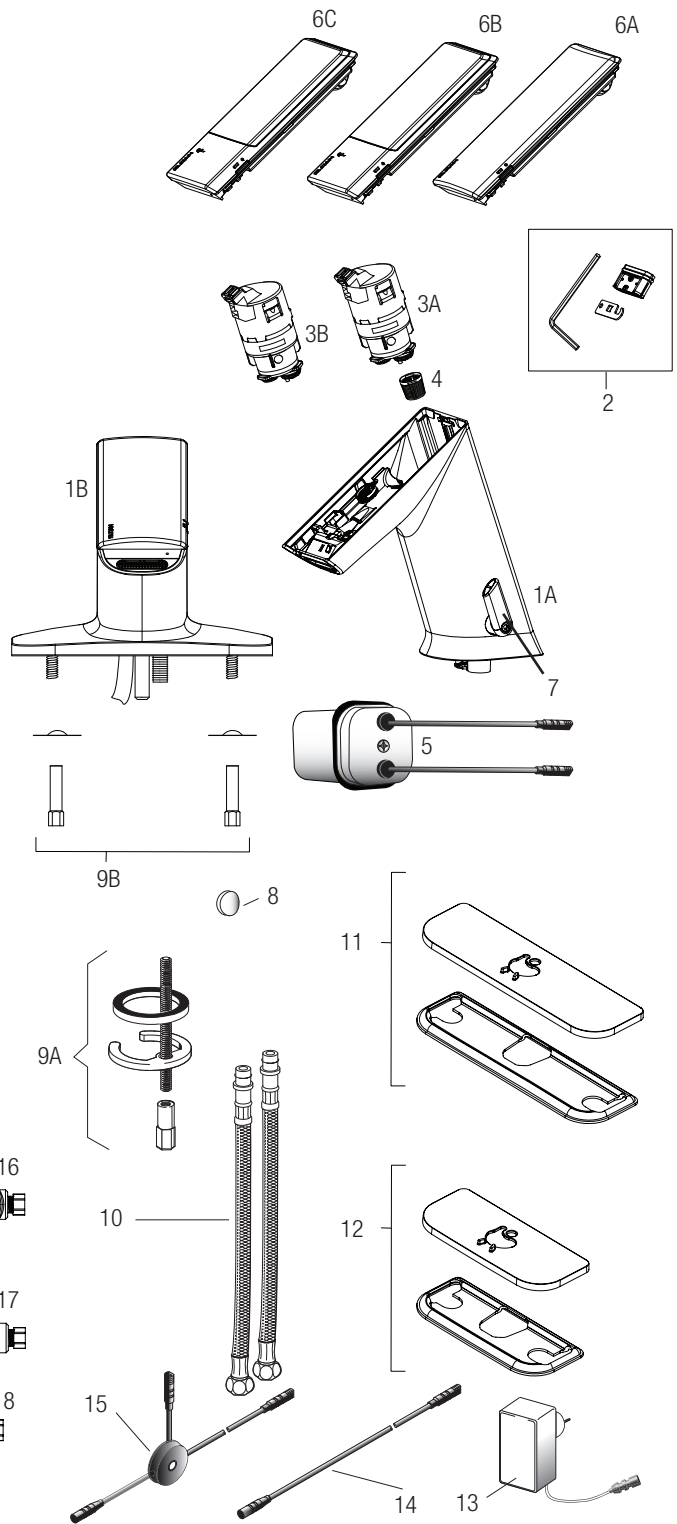

**NOTE: If changing flow rate caddy and spray insert must be changed in conjunction.**

† Single Supply faucets include Bak-Chek®

\* Integral Base model not available with integral to faucet side mixer; single supply faucets include Bak-Chek®

Manufactured by Sloan Valve Company under one or more of the following patents: U.S. Patents. Other Patents Pending. BAK-CHEK®, BASYS™, Any Application. Any Environment.™

The information contained in this document is subject to change without notice.

**SLOAN • 10500 SEYMOUR AVENUE • FRANKLIN PARK, IL 60131**

Phone: 1-800-9-VALVE-9 (1-800-982-5839) • Fax: 1-800-447-8329 • [www.sloan.com](http://www.sloan.com)