

ECOS® Flushometers

Single-flush and Dual-flush

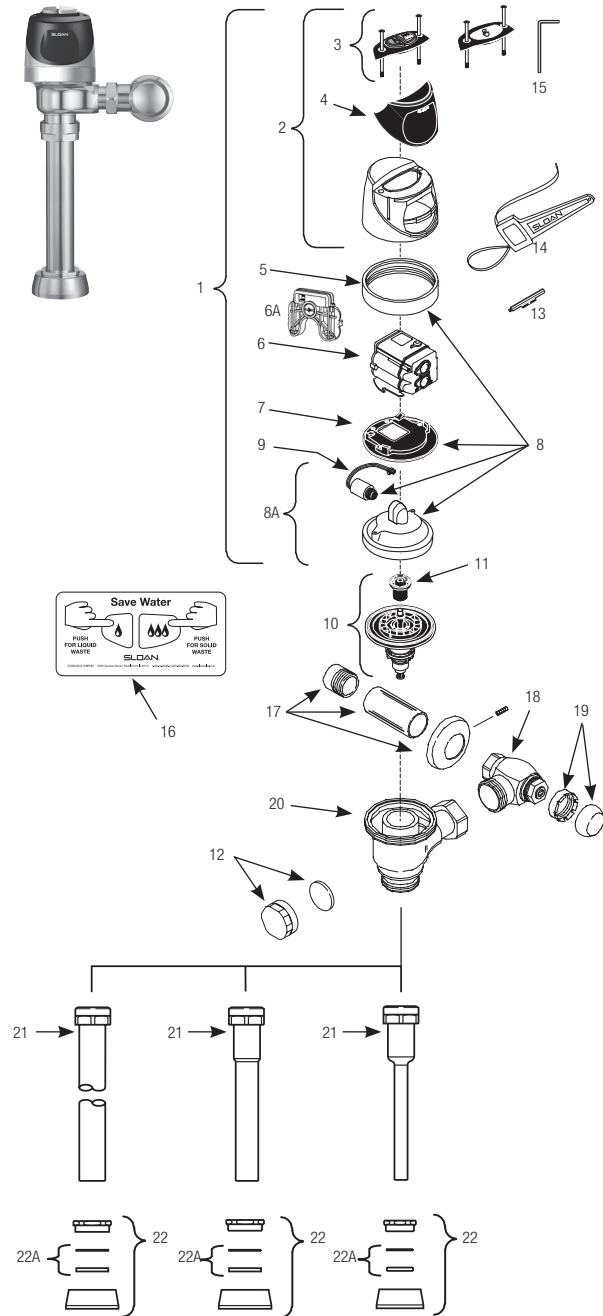

FLEX TUBE DIAPHRAGM ASSEMBLY



Sloan ECOS® Electronic Valve Models Feature Sloan's Exclusive flex tube diaphragm™ for the ultimate in valve performance, reliability and chloramine resistance.

Items Included with Complete Sloan ECOS Valves Only

21A.	3393002	V-600-AA	1½" (38 mm) x 10 ½" (254 mm)
			Vacuum Breaker (Model 8110) (10" Outlet Tube)
	0323044	V-600-AA	1½" (38 mm) x 23" (584 mm)
			Vacuum Breaker (Model 8115)
	0393049	V-600-AA	1½" (38 mm) x 26" (660 mm)
			Vacuum Breaker (Model 8116)
21B.	0323117	V-600-AA	¾" (20 mm) x 10 ½" (254 mm)
			Vac Breaker (Model 8186) (10" Outlet Tube)
	0393039	V-600-AA	1¼" (31 mm) x 13½" (342 mm) Vac Breaker
22A.	0306146	F-5-AT	1½" Spud Coupling Assembly (Water Closet Models)
22B.	0306125PK	F-5-AW	¾" Spud Coupling Assembly (Urinal Models)

Item.	Code.	Part #	Description
-------	-------	--------	-------------

Items Included with RESS Retrofit and Complete Sloan ECOS Flush Valves

1.	0372055	WES-55-A	Cover/Ring/Sensor Assembly - Dual Flush WC
	0325160	EBV-138-A	Cover/Ring/Sensor Assembly - 1.6 & 1.28 gpf Single Flush WC
	—	EBV-378-A	Cover/Ring/Sensor Assembly - 1.1 gpf Single Flush WC
	0325161	EBV-139-A	Cover/Ring/Sensor Assembly - 1.0 gpf Single Flush Urinal
	0325341	EBV-341-A	Cover/Ring/Sensor Assembly - 0.5 gpf Single Flush
	0325329	EBV-329-A	Cover/Ring/Sensor Assembly - 0.25 gpf Single Flush
	0325273	EBV-324-A	Cover/Ring/Sensor Assembly - 0.125 gpf Single Flush
	0372060	WES-60-A	Cover/Ring/Sensor Assembly Dual Flush WC-fits Zurn® valve bodies
	0325166	EBV-149-A	Cover/Ring/Sensor Assembly 1.6 & 1.28 gpf Single Flush Water Closet-fits Zurn® valve bodies
	0325167	EBV-150-A	Cover/Ring/Sensor Assembly Single Flush Urinal fits Zurn® valve bodies
	33720003	EBV196A-BT‡	Cover/Ring/Sensor Assembly - 1.6/1.1 gpf Dual Flush WC
	33720002	EBV1054A-BT‡	Cover/Ring/Sensor Assembly - 1.1/1.28 gpf Dual Flush WC
2.	0325246	EBV-191-A	Cover Assembly - Dual Flush
	0325168	EBV-142-A	Cover Assembly - Single Flush
3A.	0372033	WES-23-A	Button Cover Assembly with Screws - Dual Flush
	0325172	EBV-130-A	Button Cover Assembly with Screws - Single Flush
	0325242	EBV-182-A	Button Cover Assembly L/OR w/ Screws
3B.	0325170	EBV-132-A	Screws (2) and Hex Wrench Only
4.	0325169	EBV-131	Lens Window Cover
5.	0325210PK	EBV-168	Locking Ring
	3325524	EBV-31-A	Locking Ring - fits Zurn® valve bodies
6.	0325247	EBV-196-A	Module - ECOS Electronic 1.6/1.1 gpf Dual Flush
	—	EBV-383-A	Module - ECOS Electronic 1.1 gpf Single Flush
	3325450	EBV-129-AC	Module - ECOS Electronic 1.6 & 1.28 gpf Single Flush
	0325395	EBV-386 AU	Single Flush 0.125 gpf/0.5 Lpf
	0325396	EBV-387 AU	Single Flush 0.25 gpf/1.0 Lpf
	3325451	EBV-129-AU	Module - ECOS Electronic 0.5 & 1.0 gpf Single Flush
	33250045	EBV-386A-BT‡	Module -ECOS Electronic Urinal 0.125 gpf
	33250046	EBV-387A-BT‡	Module -ECOS Electronic Urinal 0.25 gpf
	33250049	EBV-383A-BT‡	Module -ECOS Electronic Water Closet 1.1 gpf
6A.	33250011	—	Battery Door Replacement
7	0325171	EBV-134	Cover Rest Plate
8.	3325089	EBV-1010-A	Inner Cover Repair Kit (Metal)
8A.	3325456	EBV-145-A	Inside Cover Assembly (includes solenoid)
9.	3325453	EBV-136-A	Solenoid
10A.	†		Flex Tube Diaphragm Assembly
10B.	†		Cartridge Assembly
11.	†		Flush Volume Regulator
12.	3325814	EBV-1017-A	Handle Cap (RESS Retrofit Models only)
13.	0325194	EBV-91	Range Adjustment Tool
14.	0305823	EBV-22	Strap Wrench
15.	0325159	EBV-137	7/64" Hex Wrench
16.	0372031	WES-19	English Operation Instruction Plate
	—	WES-22	Spanish Operation Instruction Plate
17.	3388015	H-1015	Flow Control Kit (HEU Only) (Not Shown)

Items Included with Complete Sloan ECOS Valves Only

17A.	3308782	H-633-AA	1" (25 mm) Sweat Solder Kit
17B.	3308788	H-636-AA	¾" (20 mm) Sweat Solder Kit
18A.	0388000	H-700-A	1" (25 mm) Bak-Chek® Control Stop
18B.	0388001	H-700-A	¾" (20 mm) Bak-Chek® Control Stop
19	3308797	H-1010-A	Vandal Resistant Stop Cap
20.	0305381PK	EBV-36-A	Valve Body

The EBV-1020-A Kit is supplied with multiple Flush Volume Regulators. The installer must use the correct Regulator when installing the kit. †The brands and/or products referenced herein may be subject to trademark rights of their respective owners. Use of the brands and names is for identification purposes only and does not imply affiliation with or endorsement by Sloan.

† Part No. varies with valve model variation; consult factory.

ECOS® Flushometers

Single-flush and Dual-flush

ITEM 10. FLEX TUBE DIAPHRAGM KIT SELECTION GUIDE

Code No.	Part No.	Description	Regulator Color
3325003	EBV-1023-A	0.5 gpf/1.9 Lpf Urinal	GREEN
3325031	EBV-1024-A	1.28 gpf/4.8 Lpf Closet	GREEN
3325090	EBV-1025-A	0.125 gpf/0.5 Lpf or 0.25 gpf/ 1.0 Lpf Urinal	GREEN
3325121	EBV-1028-A	1.1 gpf/4.2 Lpf Closet	GRAY

EBV-1025-A includes H-1015A Flow Control

EBV-1020-A Kit is supplied with multiple Flush Volume Regulators. The installer must use the correct Regulator when installing the kit.

EBV-1020-A 1.6 gpf also for use for DF

ITEM 11. REGULATORS

The flush volume of the flex tube diaphragm kit is controlled by the regulator. Regulators are identified by color. Some flex tube diaphragm kits are supplied with multiple regulators. The installer must make sure the proper regulator is used when installing the flex tube diaphragm kit.

REGULATOR (SOLD 6 PER PACKAGE)

Code No.	Part No.	Description	Regulator Color
5325122	EBV-95	Urinal-0.5 gpf/1.9 Lpf	GREEN
5325122	EBV-95	Closet-1.28 gpf/4.8 Lpf	GREEN

FLEX TUBE DIAPHRAGM ASSEMBLY

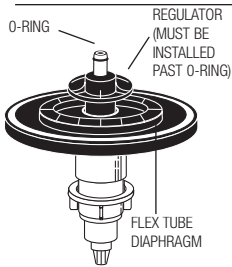

Sloan ECOS® models feature Sloan's exclusive flex tube diaphragm for the ultimate in valve performance, reliability and chloramine resistance.

ITEM 22A. SLIP JOINT GASKETS AND RINGS

Size	Code No.	Part No.	Description
1-1/2"	5306058	F-3	Red Friction Ring
	5322001	VBF-5	Black Slip Joint Gasket
	0319086/5319086	S-30	Flexible Seat
1-1/2" x 1-1/4"	0319079	S-21	Rigid Seat (rubber over brass)
	0396062	F-105	Slip Joint Gasket – Rigid
1-1/4"	5306057	F-3	Red Friction Ring
	5322176	VBF-5	Black Slip Joint Gasket
	0307052/5307052	G-21	Rigid Seat (rubber over brass)
1"	5306056	F-3	Red Friction Ring
	5306115	F-5	Black Slip Joint Gasket
3/4"	5306055	F-3	Red Friction Ring
	5306113	F-5	Black Slip Joint Gasket

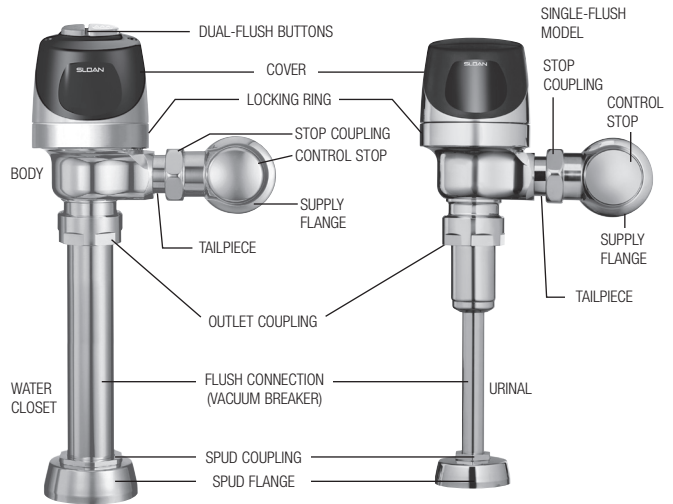

OPERATION

Manual Operation

Sloan ECOS® electronic dual-flush flushometers incorporate intuitive split-button design for easy manual activation. The small button controls the reduced flush cycle (1.1 gpf/4.2 Lpf), the large button controls the full flush cycle (1.6 gpf/6.0 Lpf). Straightforward graphics alert user to proper activation. Reduced flush for liquid waste, full flush for solid waste. To further educate the user, two (2) instructional wall plates are included with each Sloan ECOS dual-flush flushometer. For single-flush operation a single button is available for user's discretion.

Automatic Operation

Sloan ECOS electronic flushometers can also be activated via multi-lobular infrared sensor. By detecting user presence and duration, the Sloan ECOS Smart Sense Technology™ will determine the proper flush volume for unequalled water efficiency.

1. A continuous, INVISIBLE light beam is emitted from the Sloan ECOS sensor.
2. As the user enters the beam's effective range, 22 to 42 inches (559 mm to 1067 mm) for closet installations and 15 to 30 inches (381 mm to 762 mm) for urinal installations, the beam is reflected into the scanner window to activate the output circuit. Once activated, the output circuit continues in a "hold" mode for as long as the user remains within the effective range of the sensor. For dual-flush models, if the user stays longer than 65 seconds, a full flush will automatically initiate when the user leaves. For single-flush models, once the user steps away, a full flush will automatically initiate.
3. For a dual-flush model, once a user is detected, if the user leaves in 65 seconds or less, a reduced flush will automatically initiate. The circuit automatically resets and is ready for the next user. For a single-flush model, when the user steps away, this initiates a full flush. The circuit automatically resets and is ready for the next user.

CLOSET

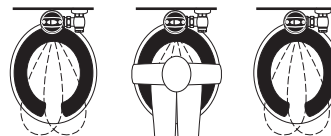

SQUAT TOILET

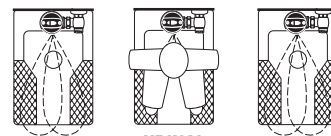

URINAL

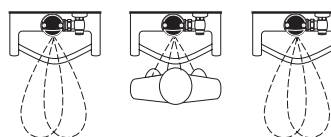

ECOS® Flushometers

Single-flush and Dual-flush

BATTERY REPLACEMENT

When required, replace batteries with four (4) AA-Size Batteries.

Note: Water DOES NOT have to be turned off to replace batteries.

Loosen the two (2) screws on top of unit. Remove the complete cover assembly. Lift the sensor module from its plate. Unplug the electrical connector from battery compartment cover. Loosen the retaining screw on battery compartment cover and remove battery compartment cover. Install four (4) alkaline type AA batteries **exactly** as illustrated at right.

Install battery compartment cover and secure with retaining screw. Make certain that battery compartment cover is fully compressed against gasket to provide a seal; **DO NOT** overtighten. Plug the electrical connector into the battery compartment cover. Reinstall the sensor module onto the plate. Reinstall the complete cover assembly onto the plate. Tighten the two (2) screws on top of the unit.

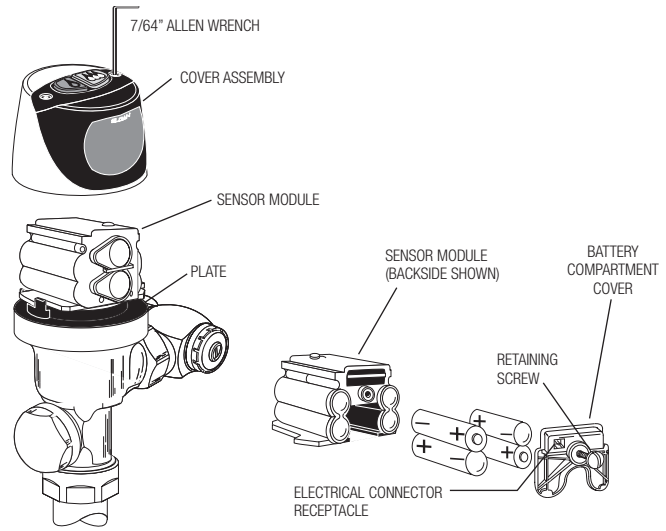

RANGE ADJUSTMENT (ADJUST ONLY IF NECESSARY)

The Sloan ECOS® electronic flushometer has a factory set sensing range:

Water closet models – 22" to 42" (559 mm to 1067 mm)

Urinal models – 15" to 30" (381 mm to 762 mm)

The Factory setting should be satisfactory for most installations.

If the range is too short (i.e., not picking up users) or too long (i.e., picking up opposite wall or stall door) the range can be adjusted.

Note: Water DOES NOT have to be turned off to adjust range.

Loosen the two screws on top of the unit. Remove the override button. Remove the rubber plug from top of electronic sensor module to uncover the potentiometer.

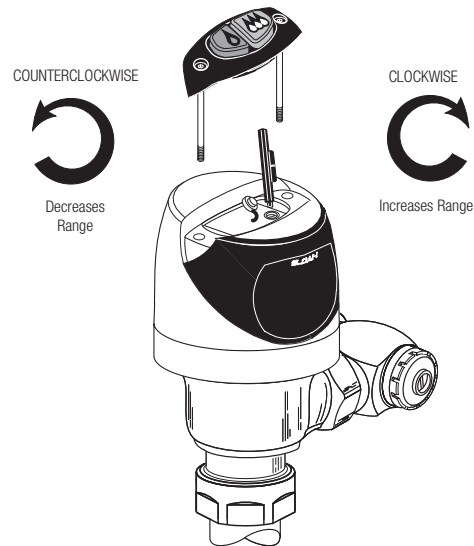

RANGE ADJUSTMENT PROCEDURE

For the first ten (10) minutes of operation, a visible light flashes in the sensing window of the Sloan ECOS electronic flushometer when a user is detected. This visible light feature can be reactivated after ten (10) minutes by opening and closing the battery compartment door.

Check the range by stepping toward the unit until the light flashes, indicating the sensor's maximum detection limit. Adjust the range potentiometer screw located on top of the sensor module a few degrees **CLOCKWISE** to increase the range or a few degrees **COUNTERCLOCKWISE** to decrease the range. Repeat this adjustment until the desired range is achieved.

Always determine the sensing range with metal cover and lens window on top of the unit.

IMPORTANT: Adjust in small increments only! Range potentiometer adjustment screw rotates only 3/4 of a turn; DO NOT over-tighten.

When range adjustment is satisfactory, replace the rubber plug. Reinstall override button and tighten the two screws on top of the unit.

RECOMMENDED WALL PLATE LOCATIONS – FOR DUAL-FLUSH FLUSHOMETERS

Centered over flushometer

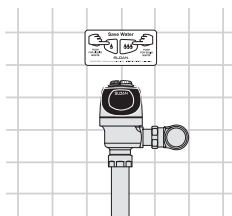

On stall door

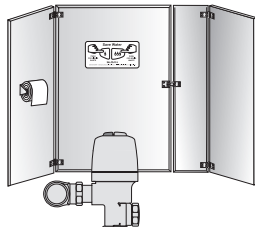

ECOS® Flushometers

Single-flush and Dual-flush

TROUBLESHOOTING AND MAINTAINING THE SLOAN ECOS® FLUSHOMETER

1. Sensor flashes continuously only when user steps within range.

- A. Unit in start-up mode; no problem. This feature is active for the first ten (10) minutes of operation.

2. Valve DOES NOT flush; sensor not picking up user.

- A. Range too short; increase the range.

3. Valve DOES NOT flush; sensor picking up opposite wall or surface, or only flushes when someone walks by. Light flashes continuously for first 10 minutes even with no one in front of the sensor.

- A. Range too long; shorten range.

4. Valve DOES NOT flush even after adjustment.

- A. Range adjustment potentiometer set at full "max" or full "min" setting. Readjust potentiometer away from full "max" or "min" setting.
- B. Batteries completely used up; replace batteries.
- C. Problem with electronic sensor module; replace electronic sensor module.

5. Unit flashes 4 Quick Times When User Steps within range.

- A. Batteries low; replace batteries.

6. Valve DOES NOT shut off.

- A. Bypass orifice in diaphragm is clogged with dirt or debris, or bypass is clogged by an invisible gelatinous film due to "over-treated" water. Remove flex tube diaphragm and wash under running water.
Note: Size of orifice in the bypass is of utmost importance for the proper metering of water by the valve. **DO NOT ENLARGE OR DAMAGE THIS ORIFICE.** Replace flex tube diaphragm if cleaning does not correct the problem.
- B. Dirt or debris fouling stem or flex tube diaphragm. Remove flex tube diaphragm and wash under running water.
- C. O-ring on stem of flex tube diaphragm is damaged or worn. Replace O-ring if necessary.
- D. Problem with electronic sensor module; replace sensor module.

7. Not enough water to fixture.

- A. Wrong flush volume regulator installed in flex tube diaphragm kit. Install the correct regulator.
- B. Wrong Sloan ECOS electronic model installed; i.e., 1.6 gpf/1.1 gpf model installed on 3.5 gal. closet fixture.
- C. Enlarged bypass in diaphragm. Replace flex tube diaphragm.
- D. Control stop not adjusted properly. Readjust control stop.
- E. Inadequate volume or pressure at supply. Increase water pressure or supply (flow) to valve. Consult factory for assistance.

8. Too much water to fixture.

- A. Wrong flush volume regulator installed in flex tube diaphragm kit. Install the correct regulator (see Step 7 of these instructions).
- B. Control stop not adjusted properly. Readjust control stop.
- C. Wrong Sloan ECOS model installed; i.e., 0.5 gpf model installed on 0.125 gal. fixture. Replace with proper Sloan ECOS electronic model.
- D. Dirt in diaphragm bypass. Clean under running water or replace flex tube diaphragm.

Note: The EBV-46-A Beam Deflector is no longer required or available for the Sloan ECOS.

CARE AND CLEANING INSTRUCTIONS

DO NOT USE abrasive or chemical cleaners to clean the flushometer as they may dull the luster and attack the plastic cover and the chrome finish of the flushometer. Use **ONLY** mild soap and water, then wipe dry with clean cloth or towel.

While cleaning the bathroom tile, the flushometer should be protected from any splattering of cleaner. Acids and cleaning fluids can discolor or remove chrome plating.

When assistance is required, please contact Sloan Technical Support at: 1-888-SLOAN-14 (1-888-756-2614).