

INSTALLATION INSTRUCTIONS FOR EAF-3X0 SERIES ELECTRONIC, SENSOR-ACTIVATED LAVATORY FAUCETS

Faucet Variations

-ISM Integral Spout Temperature Mixer



EAF-3X0



EAF-3X0-ISM

SLOAN® LIMITED WARRANTY SUMMARY

Sloan Valve Company (“Sloan”), warrants its products against defects in materials and workmanship, excluding damage caused by matters beyond Sloan’s reasonable control. Instructions for filing claims can be found in the Limited Warranty which can be obtained at www.Sloan.com or by requesting a free copy by telephone at 888.756.2614. Sloan will repair or replace your defective product, or provide a refund, as your exclusive remedy. This is only a general summary of Sloan’s Limited Warranty so it is important to note that the specific terms, conditions, limitations and exclusions, including the duration of warranty coverage for your particular Sloan product, are contained in the actual Sloan Limited Warranty. The Limited Warranty is subject to applicable laws in your country, state, province or other jurisdiction—and disputes arising under the Limited Warranty are to be resolved by binding arbitration unless you provide Sloan with an opt-out notice no later than 30 days after your purchase date. In case of a conflict with this summary, the terms and conditions set forth in the complete Limited Warranty will prevail. pose of resale. This warranty does not cover the life of batteries.

THERE ARE NO WARRANTIES WHICH EXTEND BEYOND THE DESCRIPTION ON THE FACE HEREOF. IN NO EVENT IS SLOAN VALVE COMPANY RESPONSIBLE FOR ANY CONSEQUENTIAL DAMAGES OF ANY MEASURE WHATSOEVER.

PRIOR TO INSTALLATION

Prior to installing the Sloan OPTIMA Plus® EAF-3X0 Series faucets, install the items listed below. Also, refer to rough-in illustrations.

- Lavatory/sink
- Drain line
- Hot/Cold water supply lines or pre-tempered water supply line

IMPORTANT:

- ALL PLUMBING SHOULD BE INSTALLED IN ACCORDANCE WITH APPLICABLE CODES AND REGULATIONS.
- FLUSH ALL WATER LINES PRIOR TO MAKING CONNECTIONS.
- KEEP THREAD SEALANT OUT OF YOUR WATERWAY TO

PREVENT COMPONENT PART DAMAGE! DO NOT USE ANY SEALANT ON COMPRESSION FITTINGS.

Trim Plates

When the EAF faucet is installed on a sink that has three (3) hole punchings, a trim plate should be used. **Trim plates must be specified and ordered separately.**

- ETF-312-A Trim Plate for 4” (102 mm) Centerset Sink
- ETF-510-A Trim Plate for 8” (203 mm) Centerset Sink

Tools Required for Installation

- 13mm open wrench or nut driver for faucet retainer nut
- 3/4” open end wrench for female end of flex hose

FAUCET ROUGH-IN

EAF-3X0

Faucets with Single Line Water Supply

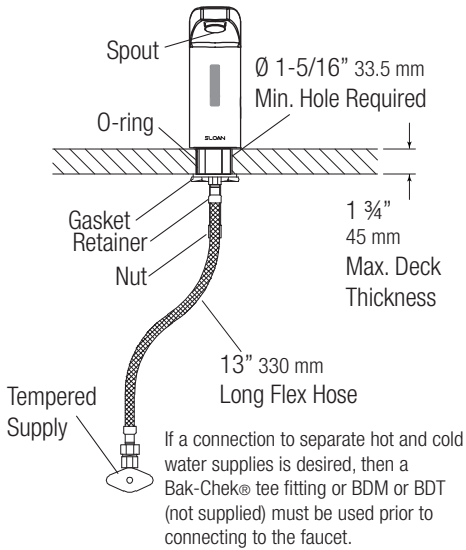

EAF-3X0-ISM

Faucets with Hot/Cold Water Supply

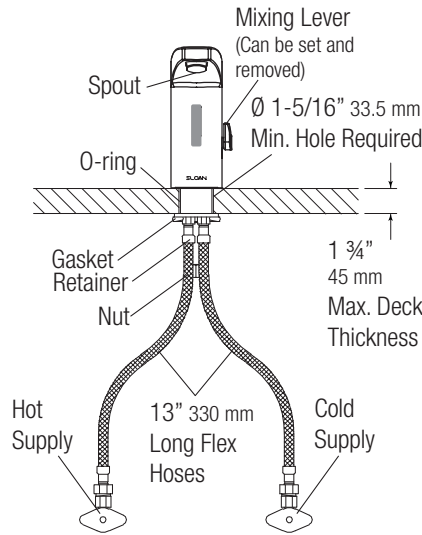

Side View

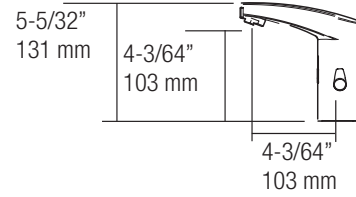

Front View

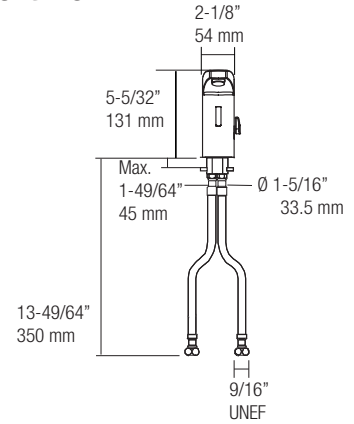

1 - INSTALL FAUCET

- A** Remove nut, faucet retainer and gasket. **DO NOT** remove the o-ring from base of faucet. **DO NOT** remove sensor label until step.4

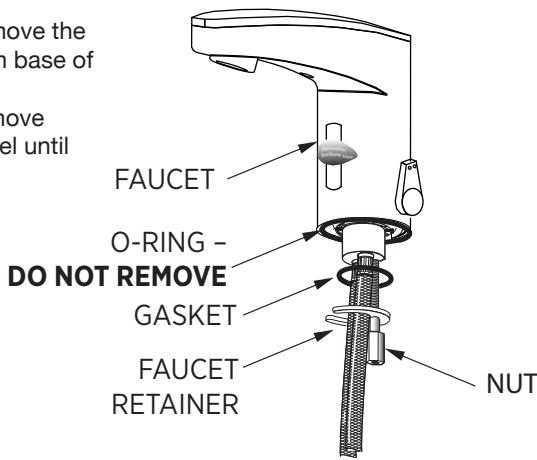

- B** Install faucet with o-ring into the center hole in deck or lavatory – **1-5/16" (33 mm) minimum hole required.** **NOTE:** if installing the faucet on a three (3) hole sink, a trim plate should be installed at this time.

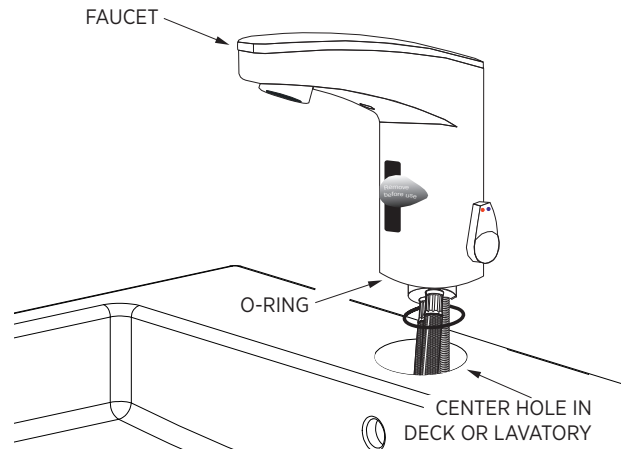

2 - SLIDE GASKET OVER FLEX HOSE(S) AND SECURE

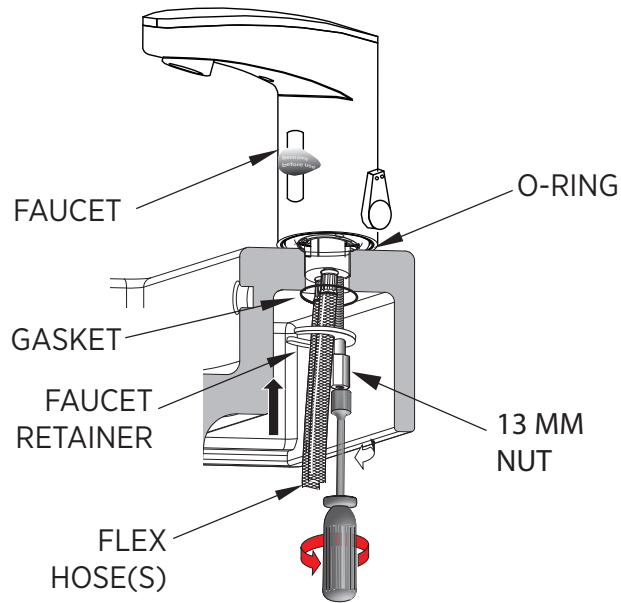

3 - INSTALL STRAINER AND FLEX HOSE ONTO SUPPLY STOP. OPEN SUPPLY STOPS.

IMPORTANT: Flush dirt, debris, and sediment from supply line(s) before connecting flex hose(s).

- A** Install strainer and flex hose(s) onto supply stop.

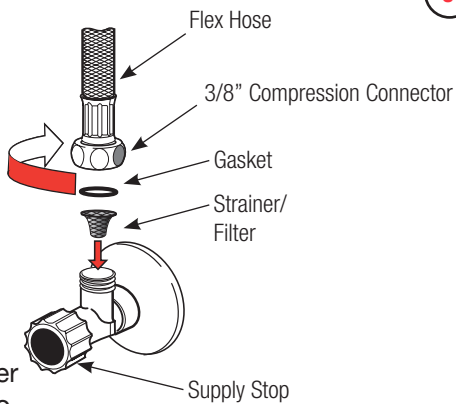

- B** Tighten the flex hose(s) (with strainer in place) securely to the supply stop(s).

- C** Open supply stop(s).

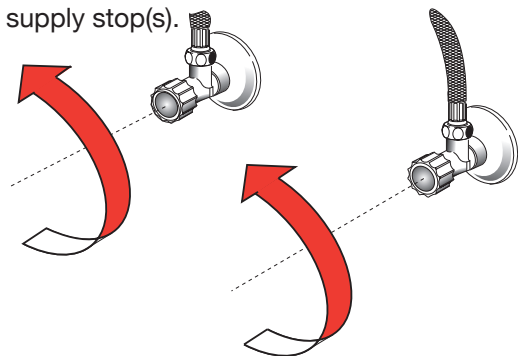

Note:

If water flows immediately upon opening supply stops, the solenoid is in the open position, and will be cycled to the closed position during the sensor startup sequence in Step 5.

4 - CONNECT TO THE POWER SUPPLY (EAF-300 MODELS ONLY)

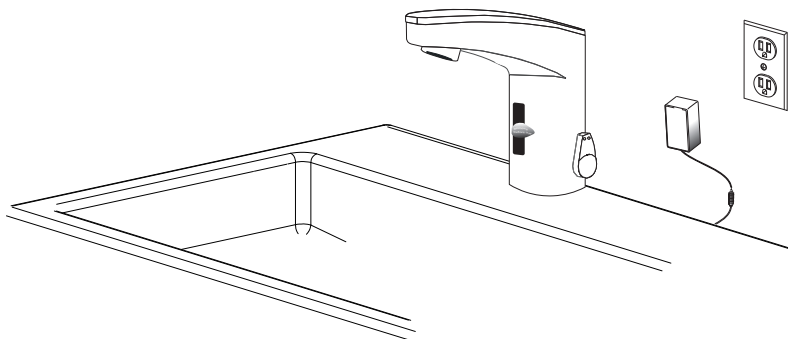

5- REMOVE LABEL FROM SENSOR

- A** Remove label from sensor window.

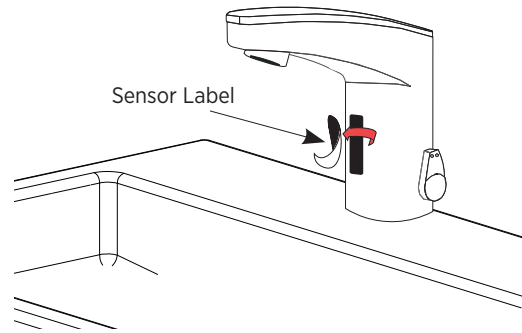

6 - ACTIVATE FAUCET

- A** Activate Faucet by holding installation instructions approximately 1-1/2" (38 mm) in front of the sensor window until red light appears, then remove instruction sheet. Faucet will run for four (4) seconds and the range will automatically adjust to its environment. Wait ten (10) seconds after water shuts off before using faucet.

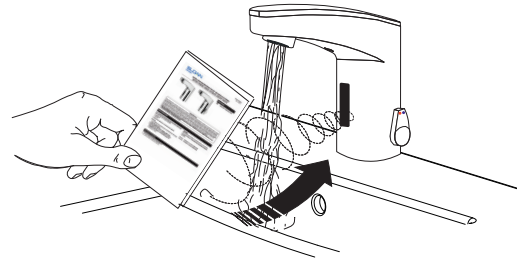

- B** Activate Faucet and check for leaks. If faucet does not function, refer to the Troubleshooting section of this instruction manual.

7 - SET AND FIX TEMPERATURE

- A** Adjust lever to set temperature.

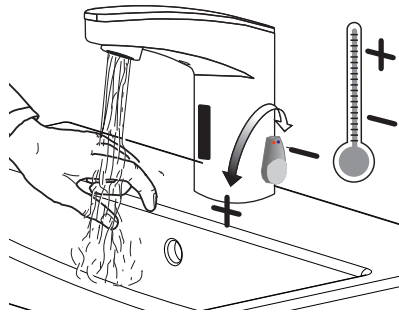

- B** Optional – To fix temperature, set lever to the desired position, then remove lever and plug hole with cap.

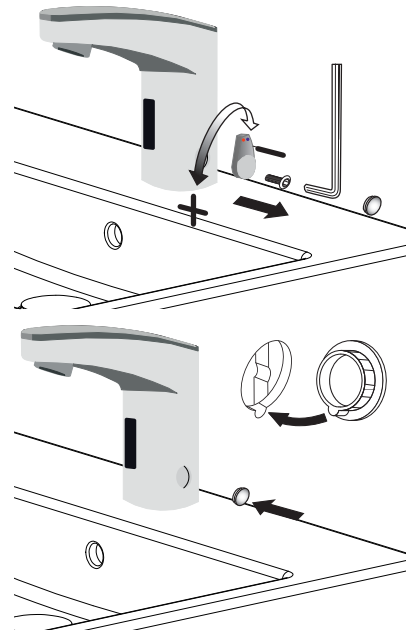

8 - BATTERY REPLACEMENT

Note: Replace battery when RED LED indicator flashes each time faucet is in use or when faucet stops functioning.

A Close supply stop(s).

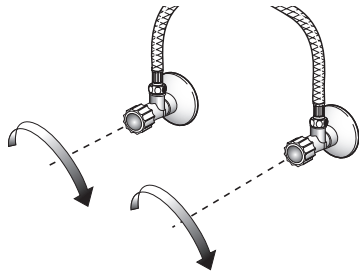

B Loosen screw with hex wrench and remove cap.

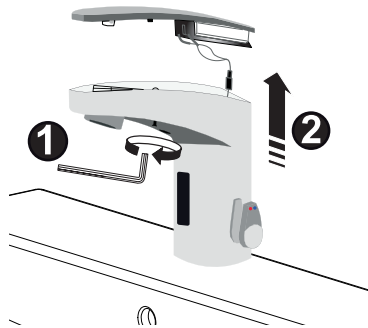

C Move battery retainer tab away from battery. Remove old battery. Dispose of properly. Wait 15 seconds before

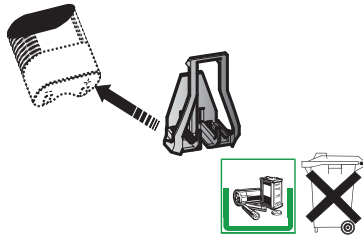

D Install new battery.

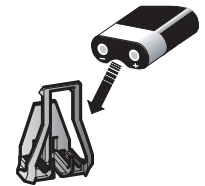

E Replace cover and tighten screw with hex wrench.

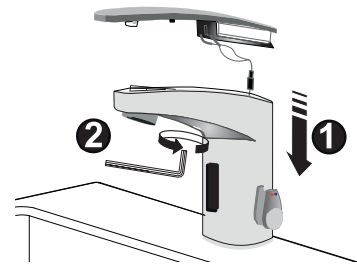

F Insert a new 6V type CR-P2 lithium battery. The RED LED will flash for one (1) minute.

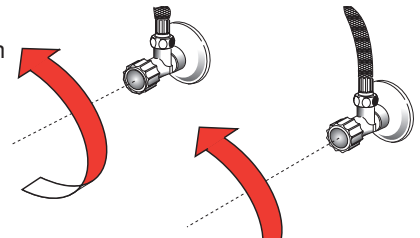

G Wait ten (10) seconds before using faucet.

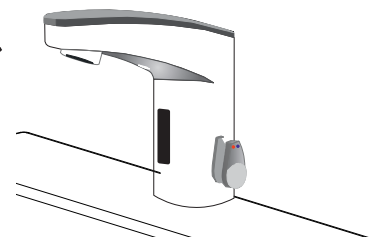

SETTINGS

IR-Click Feature

The IR-Click is a detector located in the sensor window of the faucet spout that allows the user to place the faucet into the following function modes: Continuous Run, Temporary Off and Auto Set Range Adjustment. To use the IR-Click, cover bottom half of sensor with finger, wait 2 seconds for Orange light, then remove finger. When in programming mode, each touch of IR-Click will produce a quick Orange flash.

Function	Press Button	LED Signal
Temporary OFF (2 min)	1. 1 time for 2 seconds 2. 2 times (double push)	1. LED Orange (1) 2. LED Red pulsating flashes
Reset:	1 time or will reset automatically after 2 mins	
Continuous Run 2 min default setup (adjustable from 1-20 min)	1. 1 time for 2 seconds 2. 1 time for 3-5 seconds	1. LED Orange (1) 2. Water flows after releasing
Reset:	1 time or will reset automatically after 2 mins	
Auto Set Range Adjustment Details Shown in Next Section	1. 1 time for 2 seconds 2. 2 times (double touch) 3. 1 time for 4 seconds then hold till requested range is reached 4. Release	1. LED Orange (1) 2. LED Red blinks 3. LED Red (1-8) 4. LED Orange (1)

SENSOR RANGE ADJUSTMENT

After inserting the new battery and opening the supply stops, wait 15 seconds, remove and then reinsert the battery.

A IR activation (see page 5). To enter programming mode place finger on IR-Click (covering bottom half of sensor) 1 time for 2 seconds and remove, ORANGE light will come on. Then, place finger 2 times then remove. Light on sensor should blink RED to indicate programming mode.

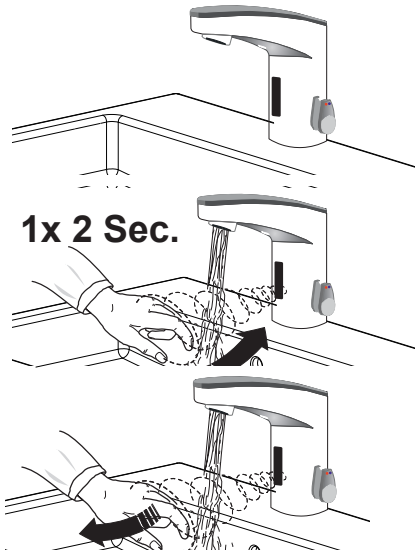

B Cover IR-Click (bottom half of sensor) until LED flashes RED 4 times - hold IR-Click until LED flashes 1 to 8 times from minimum to maximum range. See diagram below. Release when requested range is reached.

C



D

Wait until LED flashes ORANGE

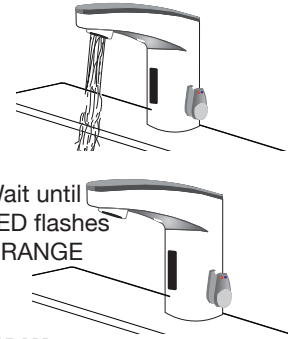

SENSOR RANGE ADJUSTMENT DIAGRAM

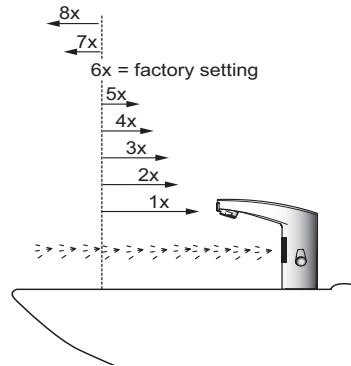

12/24 LINE PURGE FEATURE

This feature will operate the faucet every 12 or 24 hours since last use, or if not used, to prevent stagnant water conditions.

Default purge duration is two minutes.

Consult factory regarding other timing options.

Steps to activate purge line feature:

1. Activate IR: cover lower part of sensor window with a white card/paper until LED flashes ORANGE to confirm program mode is active.
2. Cover lower part of sensor window once more with a white card/paper for approximately 24 seconds (ignore LED indications during this period). Release when requested program is reached. (See LED indications to right.)

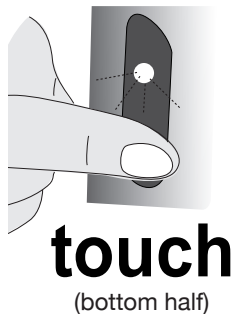

A

...1x

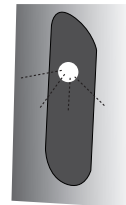

Deactivate

B

...2x

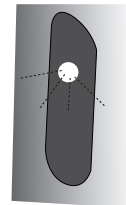

Activate 12HR

C

...3x

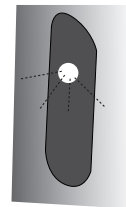

Activate 24HR

D

...4x

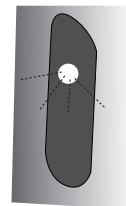

Activate 48HR

HOT LIMIT STOP ADJUSTMENT

- A** Close supply stop(s).

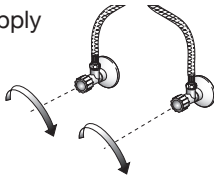

C

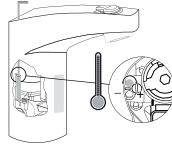

- Adjust temperature to desired limit
- Adjust screw to meet limit setting

E

- Open supply stop(s).

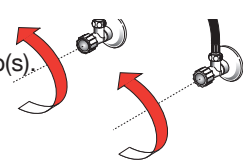

- B** Loosen screw with hex wrench and remove cap.

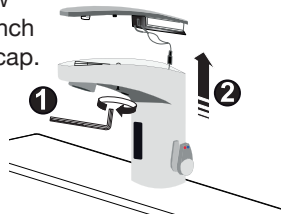

D

- Replace cover and tighten screw with hex wrench.

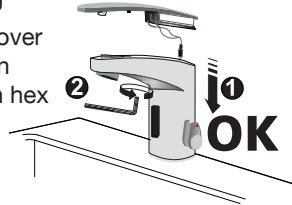

F

- Wait ten (10) seconds before using faucet.



OPERATION

As the user's hands enter the beam's effective range, the beam is reflected back into the sensor receiver and activates the solenoid valve allowing water to flow from the faucet. Water will flow until the hands are removed or until the faucet reaches its automatic time out setting.

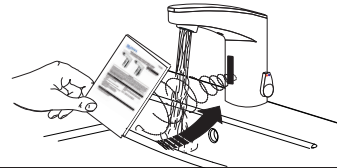

DO NOT USE abrasive or chemical cleaners (including chlorine bleach) to clean faucets that may dull the luster and attack chrome or special decorative finishes. Use **ONLY** mild soap and water, then wipe dry with clean cloth or towel.

While cleaning the bathroom tile, protect the faucet from any splattering of cleaner. Acids and cleaning fluids will discolor or remove chrome plating.



- | | |
|---|---|
| <p>1. Problem Faucet does not function.
Cause Adhesive packaging label affixed over sensor eye.
Solution Remove adhesive label from sensor eye.
Cause Permanent Off Activated shown by RED flashing LED.
Solution Touch button on sensor window for 2 seconds, RED flashing LED will stop and confirmed with ORANGE LED.</p> <p>2. Problem Faucet delivers water in an uncontrolled manner.
Solution Contact Sloan Technical Support (see below).</p> <p>3. Problem Faucet does not deliver any water with hands in sensor range.
Indicator Solenoid valve produces an audible "click."
Cause Water supply stop(s) closed.
Solution Open water supply stop(s).
Cause Water supply stop strainer(s) clogged.
Solution Turn off water at supply stop(s). Remove, clean and reinstall water supply stop strainer(s). Replace strainer(s), if required. Turn on water at supply stop(s).
Indicator Solenoid valve does not produces an audible "click."
Cause Battery low.
Solution Replace battery (refer to battery replacement).
Solution Contact Sloan Technical Support (see below)</p> <p>4. Problem After removing label water does not flow.
Use this installation guide as a target by placing it in front of the sensor (approx. 1-1/2" away) until water begins flowing, then remove installation instruction from sensor. Water will stop flowing, wait 10 seconds before using faucet.</p> | <p>5. Problem Faucet delivers only a slow flow or dribble when sensor is activated.
Cause Water supply stop(s) are partially close
Solution Completely open water supply stop(s).
Cause Water supply stop strainer(s) clogged.
Solution Turn off water at supply stop(s). Remove, clean and reinstall water supply stop strainer(s). Replace strainer(s), if required. Turn on water at supply stop(s).
Cause Spray head is clogged.
Solution Remove, clean, and reinstall spray head. Replace spray head, if required.
Solution Contact Sloan Technical Support (see below).</p> <p>6. Problem Faucet does not stop delivering water or continues to drip after user is no longer detected.
Solution Contact Sloan Technical Support (see below).</p> <p>7. Problem LED indicator blinks RED when faucet is in use.
Cause Battery low.
Solution Replace battery (refer to battery replacement)</p> <p>8. Problem The water temperature is too hot or too cold on a faucet connected to hot and cold supply lines.
Cause Supply stops are not adjusted properly.
Solution Adjust supply stops.
Cause For models with integral mixing valve – Mixing valve is set improperly for the water temperature desired.
Solution Rotate mixing valve handle clockwise to decrease water temperature or counterclockwise to increase water temperature.</p> |
|---|---|

Item No.	Part No.	Description
1	EAF-60	Cover
2	EAF-61	Cover Clip – Battery Support
3	EFX-1015-A	Battery Replacement Kit (with 2.5 mm hex key)
4A	EAF-22	1.5 gpm (5.6 Lpm) AER Spray Head
4B	EAF-63	0.5 gpm (1.9 Lpm) AER Spray Head
5A	EAF-1021-A	Electronic Sensor (15 Second Shut-off) with Fixing Clip Kit (0.5 gpm only)
5B	EAF-1018-A	Electronic Sensor (7 Second Shut-off) with Fixing Clip Kit (1.5 gpm only)
6	EAF-1019-A	Mixer Handle Assembly and Cartridge Kit
7	EAF-2	Solenoid Valve Cartridge (IQ Faucet)
8	EAF-1020-A	Integral Side Mixer Handle Kit
9	EAF-8	Back Check (2 required for ISM models)
10	EAF-1	Faucet Mounting Kit
11	EAF-1008	13" (330 mm) Flexible Supply Hose (2 required for ISM models)
12	EAF-9	Filter (2 required for ISM models)
13	EAF-11	EAF-11 Plug-In Voltage Adapter, US Plug (Only with EAF-300 models)

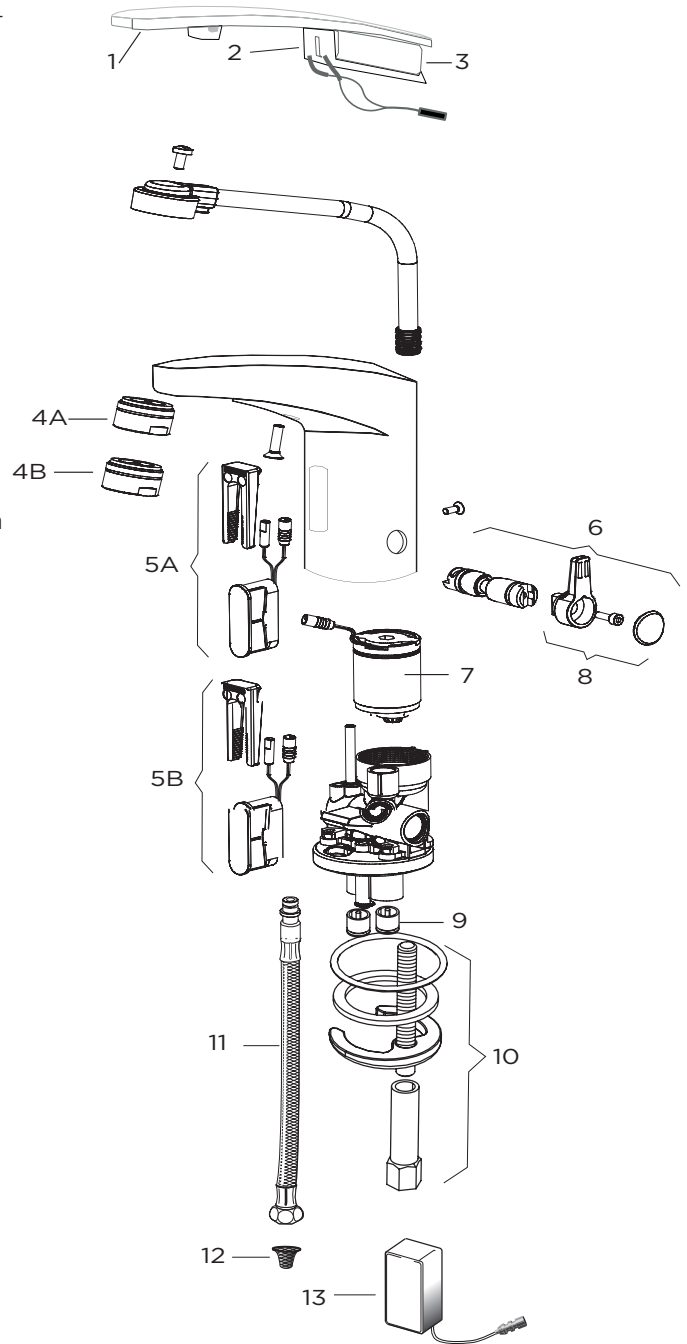

Sloan
 10500 Seymour Avenue
 Franklin Park, IL 60131
 P: 847-671-4300 / 800-9-VALVE-9
 F: 847-671-4380 / 800-447-8329
 customer.service@sloanvalve.com
 sloan.com

© 2022 SLOAN VALVE COMPANY

Code No.0816654 – Rev. 5 (07/22)