

INSTALLATION INSTRUCTIONS FOR OPTIMA I.Q. ELECTRONIC SENSOR ACTIVATED LAVATORY FAUCETS

OPTIMA® i.q.

EAF-100 Series
Adapter Powered, Sensor Activated, Lavatory Faucets

EAF-150 Series
Battery Powered, Sensor Activated, Lavatory Faucets



FAUCET VARIATIONS

-ISM	Integral Spout Mixer
-IC	<i>i.q.</i> -Click Feature
-DPU	Drain Pop Up
-P	Plug-in Transformer/Adapter (EAF-100 Series)
-LT	Less Transformer/Adapter (EAF-100 Series)

LIMITED WARRANTY

Sloan Valve Company warrants its Optima EAF-100 and EAF-150 Series Electronic Hand Washing Faucets to be made of first class materials, free from defects of material or workmanship under normal use and to perform the service for which they are intended in a thoroughly reliable and efficient manner when properly installed and serviced, for a period of three years from date of purchase. During this period, Sloan Valve Company will, at its option, repair or replace any part or parts which prove to be thus defective if returned to Sloan Valve Company, at customer's cost, and this shall be the sole remedy available under this warranty. No claims will be allowed for labor, transportation or other incidental costs. This warranty extends only to persons or organizations who purchase Sloan Valve Company's products directly from Sloan Valve Company for purpose of resale. This warranty does not cover the life of the battery.

THERE ARE NO WARRANTIES WHICH EXTEND BEYOND THE DESCRIPTION ON THE FACE HEREOF. IN NO EVENT IS SLOAN VALVE COMPANY RESPONSIBLE FOR ANY CONSEQUENTIAL DAMAGES OF ANY MEASURE WHATSOEVER.

PRIOR TO INSTALLATION

Prior to installing the Sloan Optima EAF-100/150 Series Faucets, install the items listed below. Also, refer to rough-in illustrations.

- Lavatory/sink
- Drain line
- Hot and cold water supply lines or pre-tempered water supply line.

Trim Plates

When the EAF Faucet is installed on a sink that has three (3) hole punchings, a Trim Plate should be used. **Trim Plates must be specified and ordered separately.**

ETF-607-A Trim Plate for 4" (102 mm) Centerset Sink

ETF-608-A Trim Plate for 8" (203 mm) Centerset Sink

Important:

- **ALL PLUMBING SHOULD BE INSTALLED IN ACCORDANCE WITH APPLICABLE CODES AND REGULATIONS.**
- **FLUSH ALL WATER LINES PRIOR TO MAKING CONNECTIONS.**
- **KEEP THREAD SEALANT OUT OF YOUR WATERWAY TO PREVENT COMPONENT PART DAMAGE! DO NOT USE ANY SEALANT ON COMPRESSION FITTINGS.**

TOOLS REQUIRED FOR INSTALLATION

- 13 mm open end wrench for male end of flex hose
- 5/8" open end wrench for female end of flex hose (US)
- 13 mm open end wrench or nut driver for faucet retainer nut
- 3/4" open end wrench for female end of flex hose (International)

FAUCET ROUGH-IN

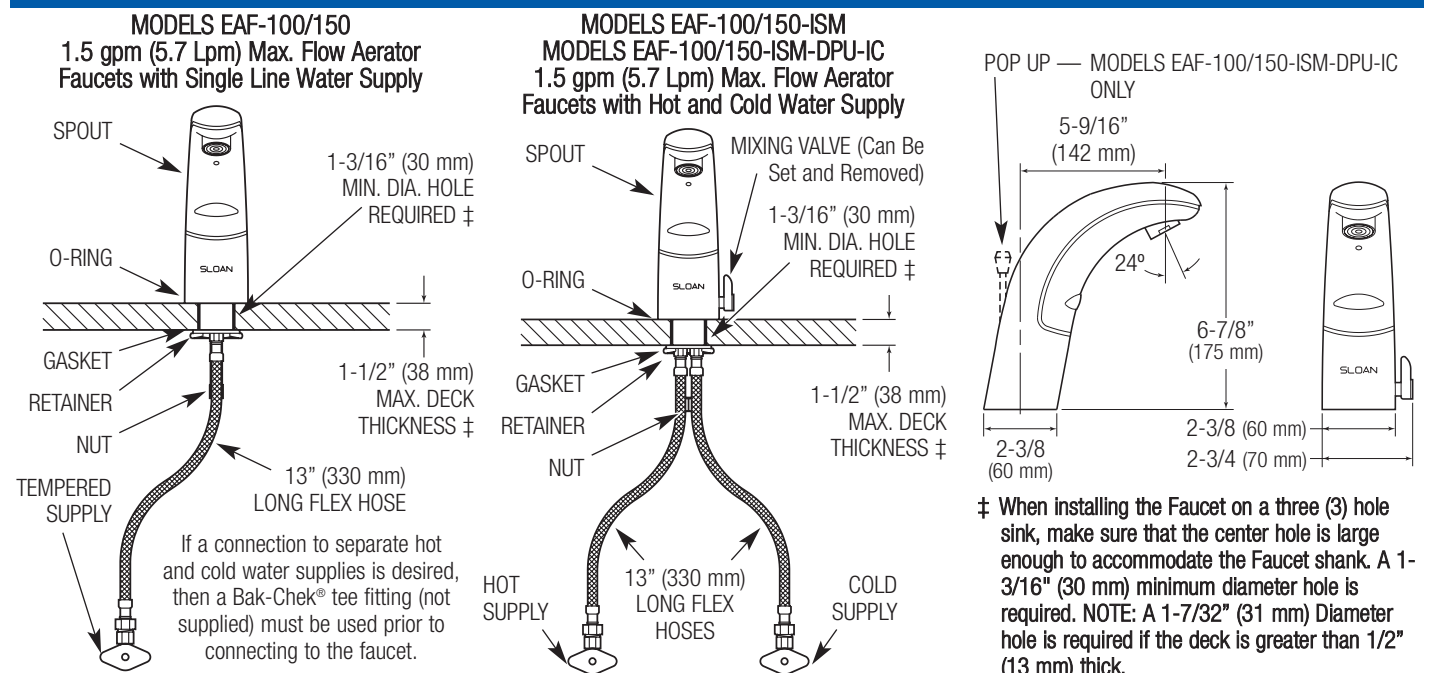

1 - INSTALL FAUCET

- A** Remove Nut, Faucet Retainer and Gasket.

Do Not remove the O-ring from base of Faucet.

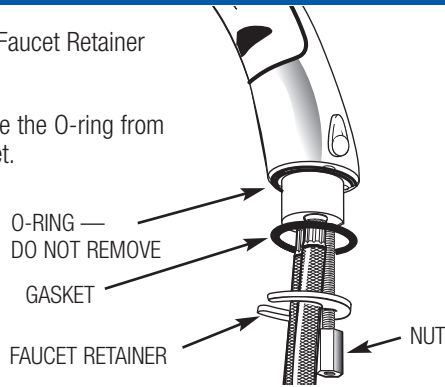

- B** Install Faucet with O-ring into the center hole in deck or lavatory — 1-3/16" (30 mm) min. hole required.

Note: If installing the Faucet on a three (3) hole sink, a Trim Plate should be installed at this time.

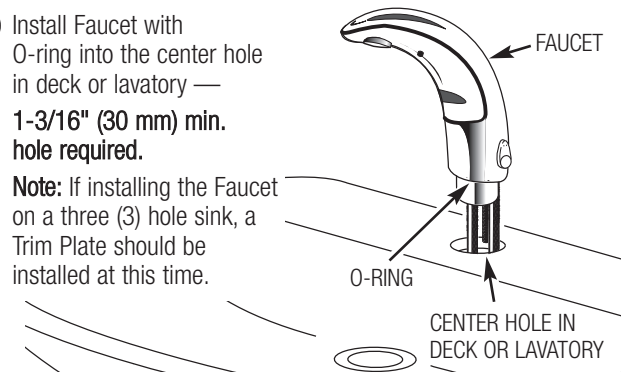

2 - SLIDE GASKET OVER FLEX HOSE(S) AND SECURE WITH FAUCET RETAINER AND NUT

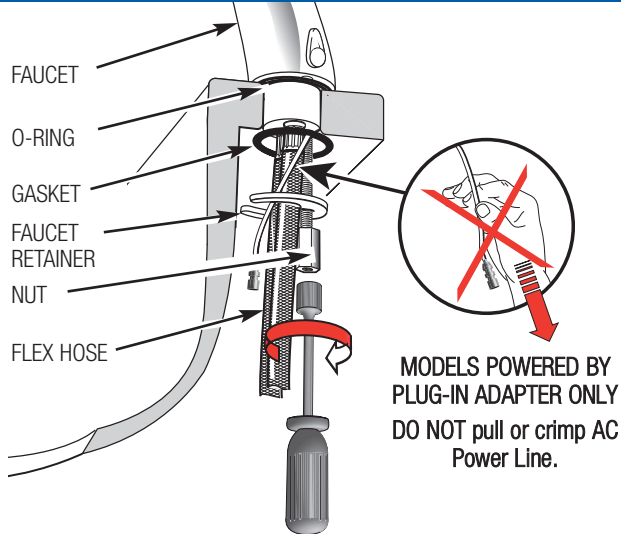

3 - INSTALL STRAINER AND FLEX HOSE ONTO SUPPLY STOP AND OPEN SUPPLY STOPS

IMPORTANT: Flush dirt, debris, and sediment from Supply Line(s) before Connecting Flex Hoses.

- A** Install Strainer and Flex Hose onto Supply Stop.

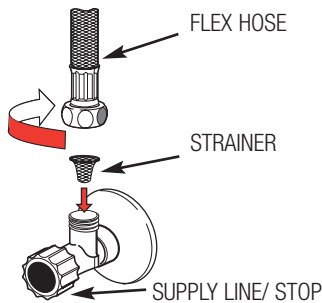

- C** Open Supply Stop(s).

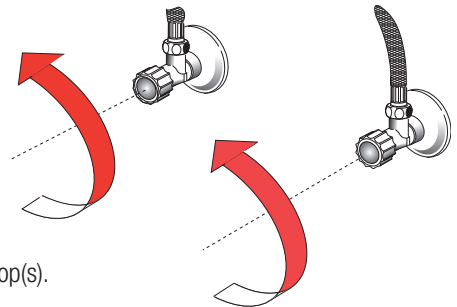

- B** Tighten the Flex Hose (with Strainer in place) securely to the Supply.

4 - EAF-100 MODELS: PLUG ADAPTER INTO RECEPTACLE ALL MODELS: REMOVE LABEL FROM SENSOR

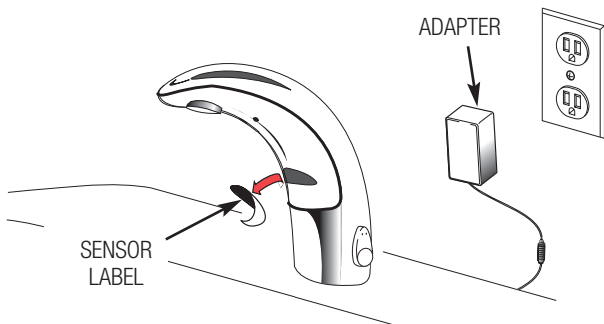

Electrical outlet must be within 24" of faucet unless extensions are used.

Electrical Connection for up to Six (6) Faucets Using One (1) Adapter

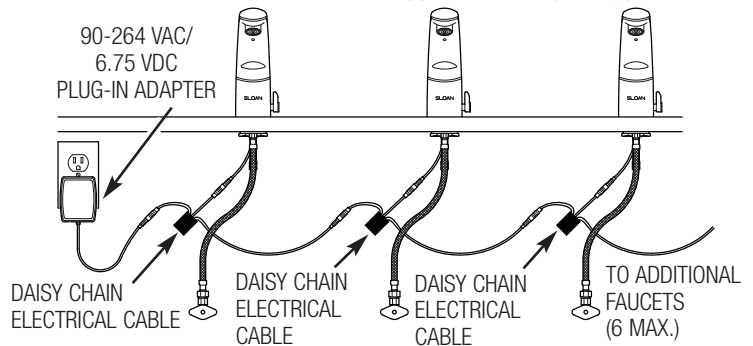

5 - ACTIVATE FAUCET

- A** Activate faucet by pressing the button one (1) time, then immediately step away.

Faucet will run for four (4) seconds and the range will automatically adjust to it's environment.

Wait ten (10) seconds after water shuts off before using Faucet.

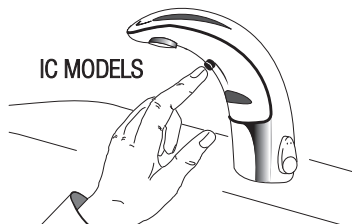

OR

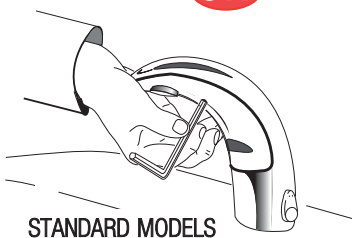

- B** Activate Faucet and check for leaks.

If Faucet does not function, refer to the Troubleshooting section of this instruction manual.

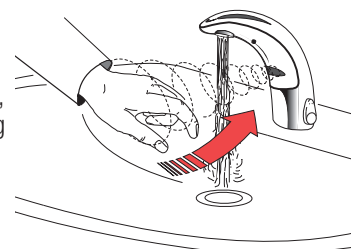

6 - SET AND FIX TEMPERATURE

- A** Adjust Lever to set temperature.

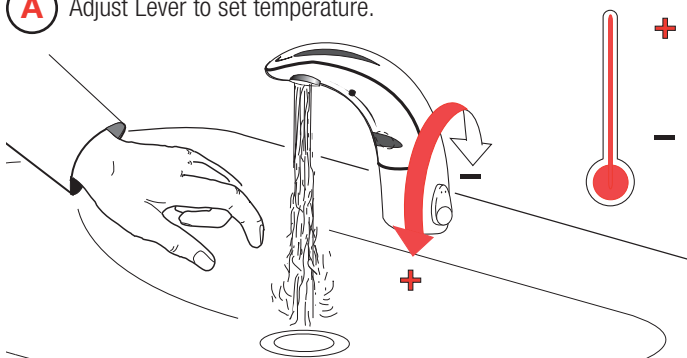

- B** Optional — To fix temperature, set lever to the desired position, then remove lever and plug hole with Cap.

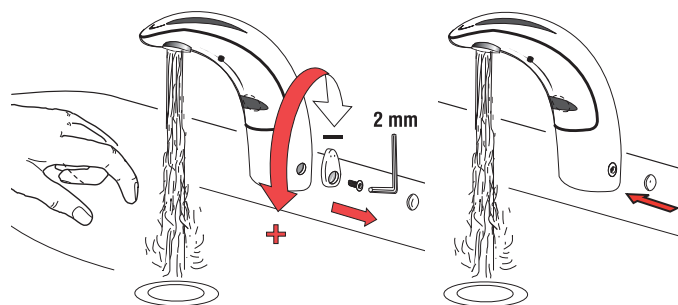

HOT LIMIT STOP ADJUSTMENT

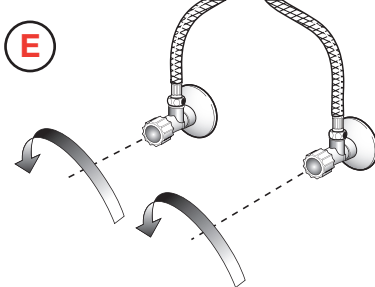
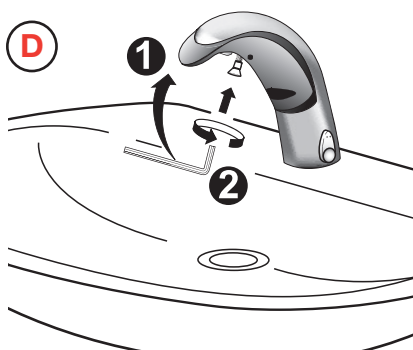
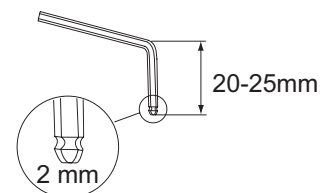
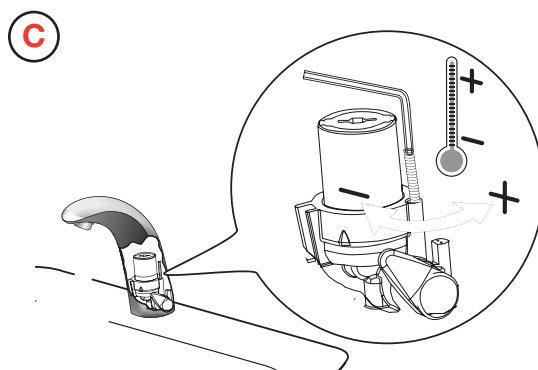
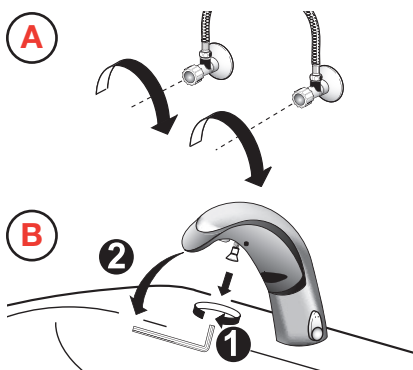

OPERATION

As the user's hands enter the beam's effective range, the beam is reflected back into the sensor receiver and activates the solenoid valve allowing water to flow from the Faucet. Water will flow until the hands are removed or until the Faucet reaches its automatic time out limit setting.

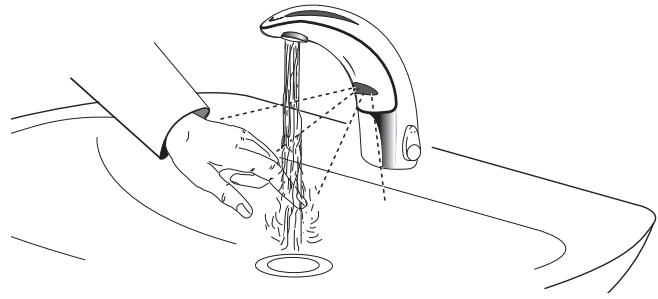

CARE AND CLEANING OF CHROME AND SPECIAL FINISHES

DO NOT use abrasive or chemical cleaners (including chlorine bleach) to clean Faucets that may dull the luster and attack the chrome or special decorative finishes. **Use ONLY mild soap and water**, then wipe dry with clean cloth or towel.

While cleaning the bathroom tile, protect the Faucet from any splattering of cleaner. Acids and cleaning fluids will discolor or remove chrome plating.

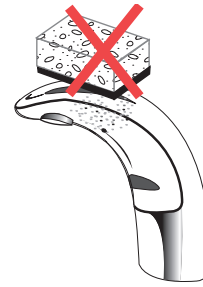

BATTERY REPLACEMENT

A Close Supply Stop(s).

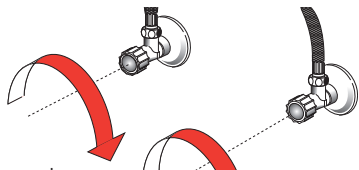

B Loosen Screw with hex wrench. Remove Throat Plate. Disconnect electrical lead at connector if required.

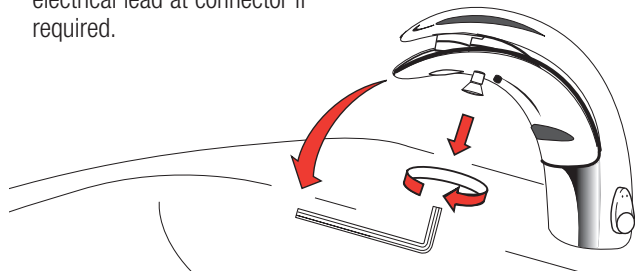

C Remove Battery Cover using a No. 1 Phillips head screwdriver. Remove old Battery and dispose of properly.

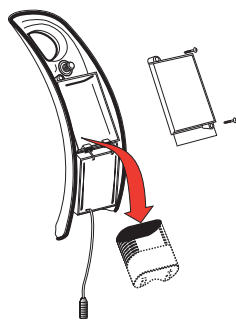

D Insert a new 6 Volt Type 2CR5 Lithium Battery. The red LED will flash for one (1) minute. Reinstall Battery Cover.

Reconnect electrical lead at connector if previously disconnected. Reinstall Throat Plate.

If LED doesn't flash or if it just lights up, remove and then reinsert the Battery.

If water flows continuously after inserting the new Battery and opening the Supply Stops, remove and then reinsert the Battery.

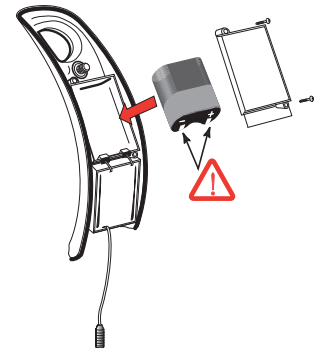

E Open Supply Stop(s).

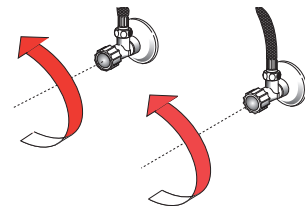

ADDITIONAL FEATURES

i.q. -Click FEATURE & SETTINGS

The **i.q.-Click** feature is a button on the underside of the Faucet spout that allows the user to place the Faucet into the following function modes: Continuous Run, Temporary Off, Permanent Off and Auto Set Range Adjustment.

Continuous Run — Water flows from 1 - 20 minutes constantly — for easy filling of sink, pail or for hygienic handwashing. Default setting is two (2) minute run time.

Temporary OFF — Water flow is deactivated up to two (2) minutes — for convenient cleaning of sink and faucet.

Auto Set Range Adjustment — All Faucets feature the Auto Set function. The detection area is automatically adapted to the sink where the Faucet is installed and this occurs upon initial power up. Thus reflection is prevented and a maximum of user convenience provided.

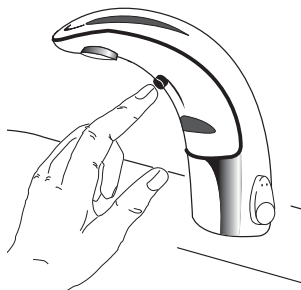

Function	Press Button	LED Signal
Continuous Run — 2 minute default setting (adjustable from 1 - 20 minutes)	1 time for 2 seconds	5 short flashes
reset:	1 time or will reset automatically after 2 minutes	
Temporary Off	2 times (double click)	5 short flashes followed by periodic flashing
reset:	1 time or will reset automatically after 2 minutes	
Auto Set Range Adjustment	2 times (double click) and then 1 time for 5 seconds	5 short flashes followed by 4 short flashes

12/24 LINE PURGE FEATURE

A

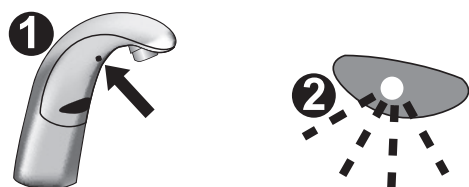

1x 24 sec +

		h
DEACTIVATE	1x	----
ACTIVATE	2x	12h
	3x	24h

This feature will operate the faucet every 12 or 24 hours since last use, if not used to prevent stagnant water conditions.

Default purge duration is two minutes.

Consult factory regarding other timing options.

SENSOR RANGE ADJUSTMENT

FACTORY SETTING IS APPROPRIATE FOR THE MAJORITY OF APPLICATIONS AND SHOULD NOT REQUIRE RESETTING UNDER EXTREME CONDITIONS.

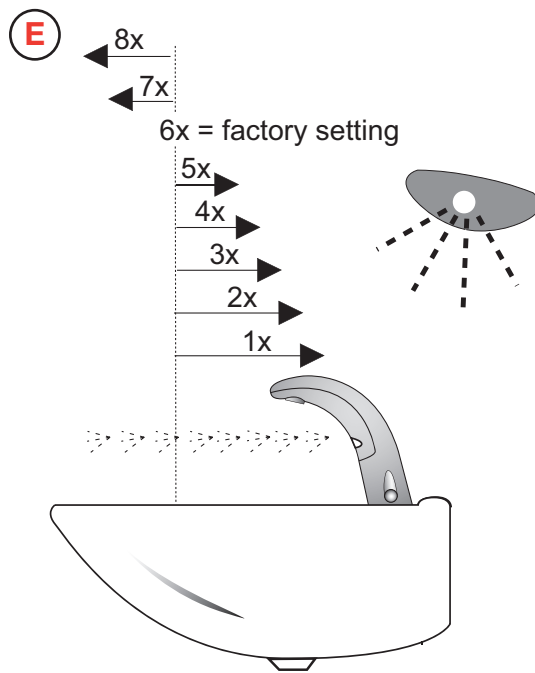
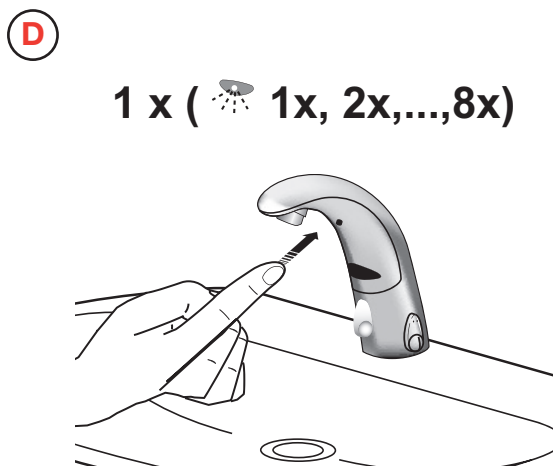
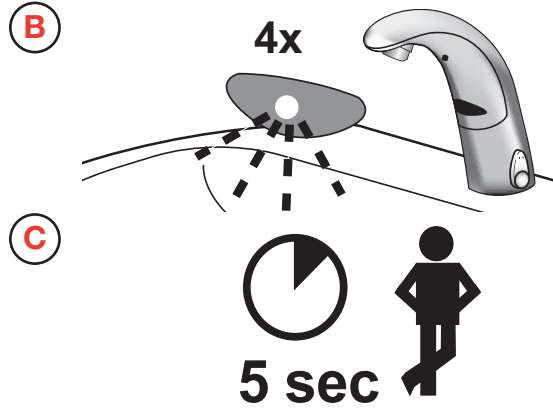
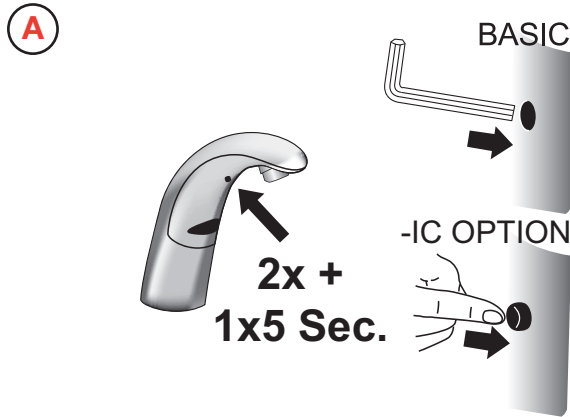

DISCLAIMER: Updated electronics have visible red and green LED. Original electronics have only red LED and range setting is reversed (1=longest, 8=shortest).



TROUBLESHOOTING GUIDE

- 1. Problem: Faucet does not function.**
Cause: Adhesive packaging label affixed over sensor eye.
Solution: Remove adhesive label from sensor eye.
Cause: "Permanent Off" activated.
Solution: Press button on Faucet throat one time.
- 2. Problem: Faucet delivers water in an uncontrolled manner.**
Cause: Faucet is defective.
Solution: Contact the Sloan Valve Company Installation Engineering Department (see below).
- 3. Problem: Faucet does not deliver any water when Sensor is activated.**
Indicator: Solenoid valve produces an audible "CLICK."
Cause: Water supply stop(s) closed.
Solution: Open water supply stop(s).
Cause: Water supply stop strainer(s) clogged.
Solution: Clean water supply stop strainer(s).
Indicator: Solenoid valve DOES NOT produce an audible "CLICK."
Cause: Battery low (EAF-150 Models).
Solution: Replace battery (refer to Battery Replacement on Page 4).
Cause: Power failure (EAF-100 Models).
Solution: Check power supply.
- 4. Problem: Faucet delivers only a slow flow or dribble when Sensor is activated.**
Cause: Water supply stop(s) are partially closed.
Solution: Completely open water supply stop(s).
Cause: Water supply stop strainer(s) clogged.
Solution: Remove, clean, and reinstall water supply stop strainer(s). Replace strainer(s) if required.
Cause: Aerator is clogged.
Solution: Remove, clean, and reinstall Aerator. Replace Aerator if required.
Cause: Faucet is defective.
Solution: Contact the Sloan Valve Company Installation Engineering Department (see below).
- 5. Problem: Faucet does not stop delivering water or continues to drip after user is no longer detected.**
Cause: Faucet is defective.
Solution: Contact the Sloan Valve Company Installation Engineering Department (see below).
- 6. Problem: LED indicator blinks when Faucet is in use.**
Cause: Battery low (EAF-150 Models).
Solution: Replace battery (refer to Battery Replacement on Page 4)
- 7. Problem: - Click doesn't function (-IC models only)**
Cause: Button is defective.
Solution: Contact the Sloan Valve Company Installation Engineering Department (see below).
- 8. Problem: The water temperature is too hot or too cold on a Faucet connected to hot and cold supply lines.**
CAUSE: Supply Stops are not adjusted properly.
SOLUTION: Adjust Supply Stops.
CAUSE: For models with integral mixing valve - Mixing valve is set improperly for the water temperature desired.
SOLUTION: Rotate mixing valve handle clockwise to decrease water temperature or counterclockwise to increase water temperature.

When assistance is required, please contact Sloan Valve Company Installation Engineering Department at:

1-888-SLOAN-14 (1-888-756-2614)

PARTS LIST

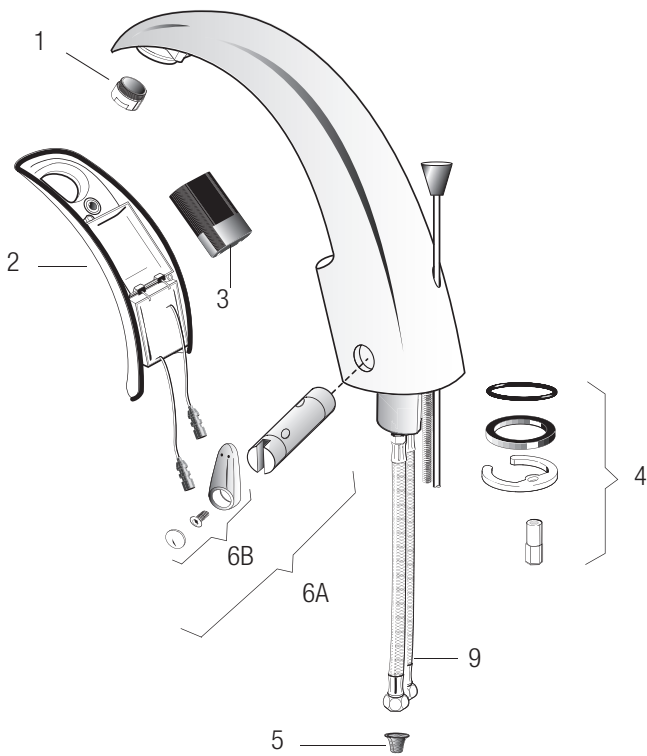

Item No.	Part No.	Description
1	EAF-22	1.5 gpm (5.7 Lpm) Aerator Spray Head
	EAF-10	2.2 gpm (8.3 Lpm) Aerator Spray Head
	EAF-12	0.5 gpm (1.9 Lpm) Spray Head
2	EAF-3-A	Throat Plate Assembly (Battery Models)
	EAF-6-A	Throat Plate Assembly (Plug-in Adapter Models)
	EAF-4-A	Throat Plate Assembly with <i>i.q.-Click</i> (Battery Models)
	EAF-7-A	Throat Plate Assembly with <i>i.q.-Click</i> (Plug-in Adapter Models)
3	EAF-1000	Battery Replacement Kit
4	EAF-1	Faucet Mounting Kit
5	EAF-9	Strainer (Filter)
6A	EAF-1001	Mixer Handle Assembly and Cartridge
6B	EAF-1002	Handle Repair Kit
7	EAF-11	90-264 VAC/6.75 VDC Plug-In Adapter (US)
8	EAF-2	Solenoid Valve
9	EAF-1008	13" (330 mm) Flexible Supply Hose
10	EAF-44	Power Splitter†
11	EAF-24-A	11-13/16" (300 mm) Extension Cable
	EAF-25-A	47-1/4" (1200 mm) Extension Cable
	EAF-17-A	126" (3200 mm) Extension Cable
12	ETF-607-A	Trim Plate for 4" Centerset Sink
13	ETF-608-A	Trim Plate for 8" Centerset Sink

† EAF-44 replaces the separate EAF-23-A Splitter Cable and EAF-28 Capacitor, which is sold separately

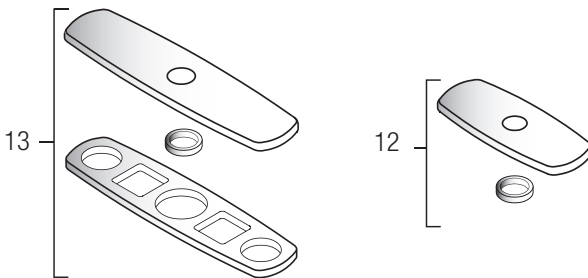
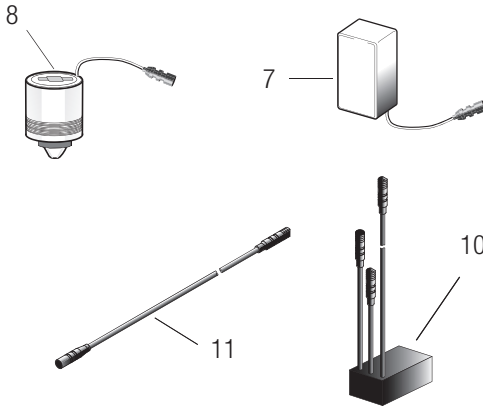

The information contained in this document is subject to change without notice.

SLOAN VALVE COMPANY • 10500 SEYMOUR AVENUE • FRANKLIN PARK, IL 60131

Phone: 1-800-9-VALVE-9 or 1-847-671-4300 • Fax: 1-800-447-8329 or 1-847-671-4380 • www.sloanvalve.com

Copyright © 2011 SLOAN VALVE COMPANY

Rev. 3 (02/11)