

Dolphin® Flushometer

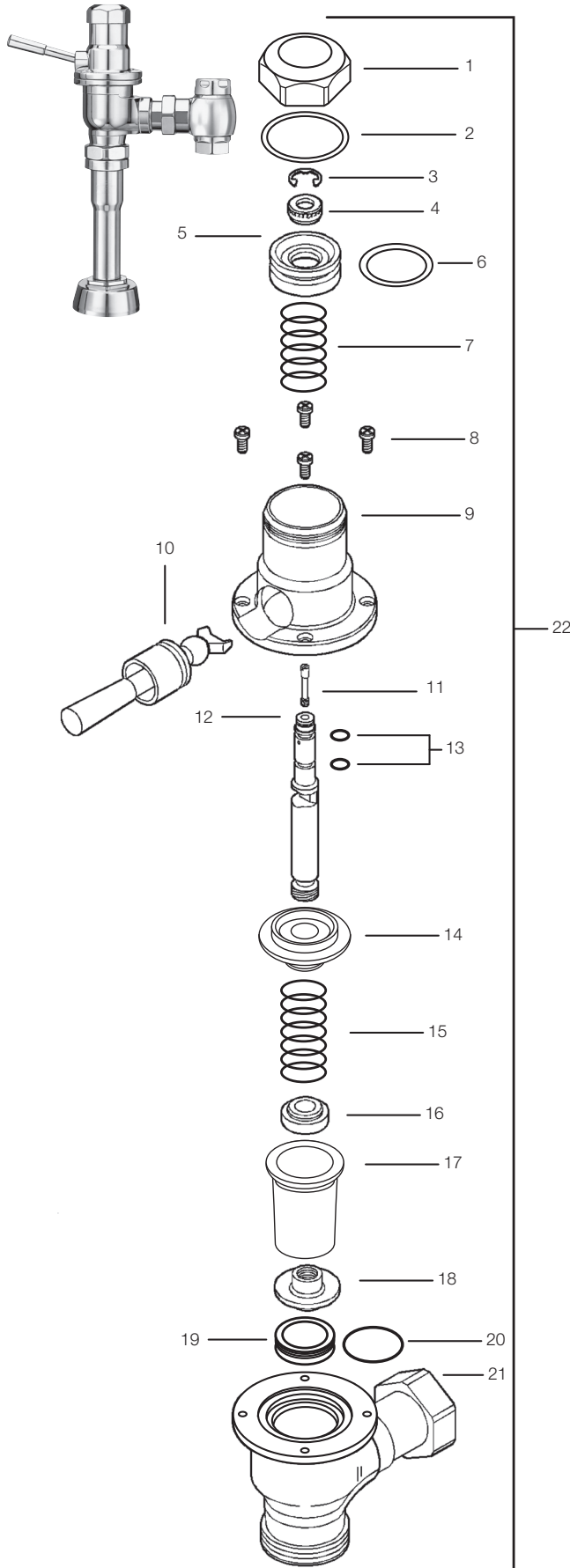

PARTS LIST—DOLPHIN® FLUSHOMETER

Item No.	Code No.	Part No.	Description
1.	0337007	DO-1	Cover Nut CP
2.	5337125	DO-2	O-ring-Seat – 1 required – 6 per package (Cover Gasket)
3.	5337129	DO-28	Retaining Ring – 1 required – 24 per package
4.	5337006	DO-4	Stem Nut RB – 1 required – 6 per package
5.	0337004	DO-5	Piston
6.	5337075	DO-6	O-ring-Piston – 1 required – 6 per package
7.	5337039	DO-7	Piston Spring – 1 required – 6 per package
8.	5337011	DO-11	Cover Screw CP – 4 required – 24 per package
9.	0337003	DO-10	Upper Body CP
10.	0337042	DO-20	Handle and Socket Assembly CP
	0337012	DO-26	Socket
11.	5337126	DO-3	Regulating Screw RB – 1 required – 6 per package
12.	0337087	DO-9	Stem RB
13.	0328336	SH-75	O-ring-Throttle Seal (2 required)
14.	0337005	DO-14	Bushing RB
15.	0337009	DO-16	Compression Spring (Main Spring)
16.	5337034	DO-17	Insert RB – 1 required – 6 per package
17.	0337018	DO-15	"Flex-Sac"
18.	0337084	DO-18	Seating Nut. Part of DO-32 "Flex-Sac" Assembly (See below)
19.	0337016	DO-19	Seat Assembly w/O-ring
20.	0337086	DO-22	O-ring
21.	0337031	DO-13-NC	Lower Body CP-Closet
	0337032	DO-13-NU	Lower Body CP-Urinal
22.	—	DO-90-AA	Complete Body Assembly
	—	DO-90-AAG	Complete Body Assembly
	—	DO-90-AAU	Complete Body Assembly

REPLACEMENT AND REPAIR KITS

A.	0337044	DO-1000-A	Piston w/ o-ring. Component parts: Items 5 and 6
B.	3337035	DO-1001-A	Repair Kit-Dolphin Handle Component parts: Items 10, 11, 12, and 13
C.	0337134	DO-32	Flex-Sac Assembly Component parts: Items 17 and 18
D.	0337136	DO-32-AA	Repair Kit-"Flex-Sac" Assembly. Component parts: Items 2, 6, 13, 17, and 18
E.	0337137	DO-32-AAN	Repair Kit-"Flex-Sac" and Stem. Component parts: Items 2, 6, 7, 13, 15, 17, 18, 19, and 20
F.	0337036	DO-19-A	Seat Assembly w/ o-ring Component parts: Items 19 and 20
G.	0337030	DO-12-A	Upper Body Assembly. Component parts: Items 1 through 7 and 9 through 18
H.	0337055	DO-13-A-NC	Lower Body Assembly for Closet. Component parts: Item 21 Lower Body, Coupling (CP), and Ground Joint Tail (CP)

Dolphin® Flushometer

PARTS LIST—DOLPHIN® FLUSHOMETER MODELS AND VARIATIONS

Item No.	Code No.	Part No.	Description
1.	0337023	DO-90-AAGNC	Closest Valve Body and Handle Assembly — Dolphin Type I
	0337025	DO-90-AAGNU	Urinal Valve Body and Handle Assembly — Dolphin Type II
2A.	0388025	H-710-A	Bak-Chek® Control Stop CP with 3/4" NPTF Inlet for Adjustable Tail
	0388022	H-710-A	Bak-Chek® Control Stop CP with 1" NPTF Inlet for Adjustable Tail
2B.	0388048	NH-710-AG	Bak-Chek® Control Stop w/ 3/4" NPTF Inlet for Ground Joint Tail (Naval Brass; use w/ Shipboard flushometer Models Type II Class A and B; requires A-35 Reducer Bushing)
	0388058	NH-710-AG	Bak-Chek® Control Stop w/ 1" NPTF Inlet for Ground Joint Tail (Naval Brass)
	0388044	NH-710-AGS	Bak-Chek® Control Stop w/ 1" NPSM Inlet for Ground Joint Tail (Naval Brass; use w/ Shipboard flushometer Models Type I and II when Sil-Brace Adapter is used)
3.	0306196	F-7	1" (25 mm) Supply Flange CP (Supplied When Valve is NOT Ordered w/ Sweat Solder Kit)
	0306191	F-7	3/4" (19 mm) Supply Flange CP (Supplied When Valve is NOT Ordered w/ Sweat Solder Kit)
4.	3308782	H-633-AA	1" (25 mm) Sweat Solder Kit with Cast Set Screw Flange CP ("–YBYC" Variation)
	3308788	H-636-AA	3/4" (19 mm) Sweat Solder Kit with Cast Set Screw Flange CP ("–YBYC" Variation)
5A.	0323013	V-500-AA	1-1/2" (38 mm) x 10-1/2" (267 mm) Vacuum Breaker Assembly CP (Model 110/111)
	0323019	V-500-AA	1-1/2" (38 mm) x 23" (534 mm) Vacuum Breaker Assembly CP (Model 115)
5B1.	0396119	F-101	1-1/2" (38 mm) x 10-1/2" (267 mm) Outlet Tube CP Type I Class B
5B2.	0306093	F-2-AT	Coupling CP w/ S-30 gasket
5C1.†	0314004	NF-1	1-1/2" (38 mm) Scored Outlet CP (Shipboard Model, Type I, Class A)
5C2.‡	2104180	F-2-AT	Coupling CP w/ S-30 gasket
5D1.	0323010	V-500-A	1-1/2" (38 mm) Vacuum Breaker Assembly CP (Model 120 does not include F-2-A Coupling, see Item 5D2 below)
5D2.	0306092	F-2-A	Coupling CP w/ S-30 gasket
5E.†	0306850	NF-29-A	Outlet Tube Assembly 3/4" (19 mm) x 6-1/2" (165 mm) Scored Outlet w/ 1/2" Offset (Shipboard Model, Type II, Class A)
5F.	0306849	NF-29-A	3/4" (19 mm) x 6-1/2" (165 mm) Flush Connection with 1/2" Offset and 3/4" x 1/2" Reducer for 1/2" Spud (Shipboard Model, Type II, Class B)
5G.‡	0323004	V-500-AA	3/4" (19 mm) x 10-1/2" (267 mm) Vacuum Breaker Assembly CP (Model 186)
5H.†	0306780	F-29-A	3/4" (19 mm) x 10-1/2" (267 mm) Flush Connection CP (Model 186–XYW)
6.†	0396302	F-109	1-1/2" (38 mm) Flush Connection CP
7.	SEE SLIP JOINT GASKETS AND RINGS TABLE ON BOTTOM, PAGE 15		
7A.	0306146	F-5-AT	1-1/2" (38 mm) Spud Coupling Assembly (Models 110/111, 115, 120)
7B.	0306125	F-5-AW	3/4" (19 mm) Spud Coupling Assembly (Model 186)
8.	0306982	F-40	1/2" (13 mm) Sil-Brace Adapter

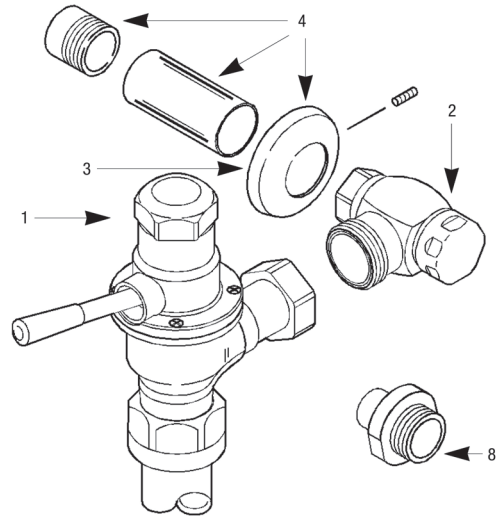

Models 110/111, 115 Shipboard Model

Models 110-XYV, 111-XYV, and Type I, Class B

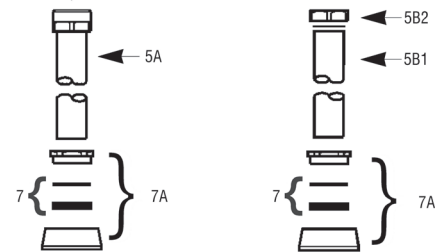

Shipboard Model, Type I, Class A

Model 120

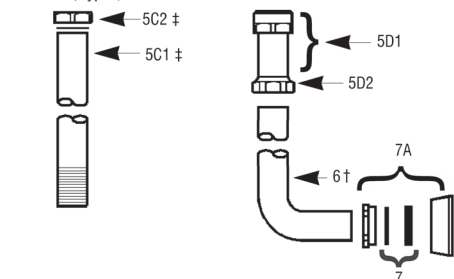

Shipboard Model, Type II, Class A

Shipboard Model, Type II, Class B

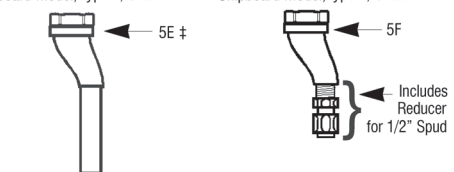

Model 186

Model 186-XYW

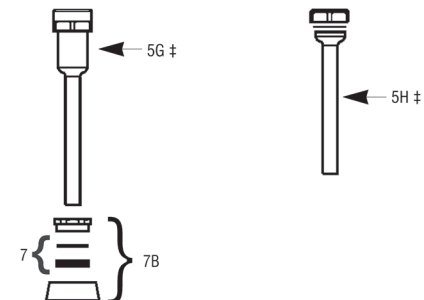

‡ Cut to proper length at installation. Allow a minimum of 5" (127 mm) between tube ends when using rubber hose for shock mounted equipment.

† This Outlet Tube is available in various lengths. Consult factory for assistance.

IMPORTANT NOTES

With the exception of the control stop inlet, DO NOT USE pipe sealant or plumbing grease on any valve component or coupling!

Protect the chrome or special finish of Sloan flushometers — DO NOT USE toothed tools to install or service these valves.

Use a A-50 Super-Wrench™ or smooth jawed spud wrench to secure all couplings. The information contained in this document is subject to change without notice.

Dolphin® Flushometer

PARTS LIST—DOLPHIN® FLUSHOMETER MODELS AND VARIATIONS

Size	Code No.	Part No.	Description
ITEM 7. Slip Joint Gaskets and Rings			
1-1/2"	5306058	F-3	Red Friction Ring
	5322001	VBF-5	Black Slip Joint Gasket
	0319086/5319086	S-30	Flexible Seat
	0319079	S-21	Rigid Seat (rubber over brass)
1-1/2" x 1-1/4"	0396062	F-105	Slip Joint Gasket – Rigid
1-1/4"	5306057	F-3	Red Friction Ring
	5322176	VBF-5	Black Slip Joint Gasket
	0307052/5307052	G-21	Rigid Seat (rubber over brass)
1"	5306056	F-3	Red Friction Ring
	5306115	F-5	Black Slip Joint Gasket
3/4"	5306055	F-3	Red Friction Ring
	5306113	F-5	Black Slip Joint Gasket

TROUBLESHOOTING GUIDE

1. Flushometer DOES NOT function.

- Control stop or main valve is closed. Open control stop or main valve.
- Handle socket assembly is damaged. Replace DO-20 handle socket assembly.

2. Volume of water is inadequate to siphon fixture.

- Control stop is not open enough. Adjust control stop for desired delivery of water volume.
- Timing of flushometer closure is set too fast. Remove DO-1 cover nut. Use a small blade screwdriver to turn DO-3 regulating screw clockwise.
- Water supply volume or pressure is inadequate. If no gauges are available to properly measure supply pressure or volume, completely open control stop and hold down flushometer handle without allowing it to close. If fixture siphons, increase timing of closure (see previous solution). If fixture does not siphon, steps must be taken to increase the supply pressure and/or volume. Contact fixture manufacturer for minimum water supply requirements of fixture.

3. Flushometer closes immediately.

- Oil chamber of upper body is empty. Remove DO-1 cover nut. Fill oil chamber with SAE 10 Oil.
- Piston seal is worn or damaged. Replace DO-6 piston O-ring seal.

4. Length of flush is too short (short flushing).

- Volume of oil in oil chamber of upper body is low. Remove DO-1 cover nut. Fill oil chamber with SAE 10 oil.
- Timing of flushometer closure is not adequately adjusted. Remove DO-1 cover nut. Using small blade screwdriver, turn DO-3 regulating screw clockwise until a satisfactory flush is achieved.

5. Length of flush is too long (long flushing).

- Timing of flushometer closure not adequately adjusted. Remove DO-1 cover nut. Using small blade screwdriver, turn DO-3 regulating screw counterclockwise until a satisfactory flush is achieved.

6. Oil is leaking from handle.

- Stem seals are worn or damaged. Replace two (2) SH-75 throttle seal O-rings.

7. Valve DOES NOT close completely (water trickle).

- Compression spring is worn or damaged. Replace DO-16 compression spring.
- Flex-sac assembly is worn. Replace DO-15 flex-sac.

CARE AND CLEANING INSTRUCTIONS

DO NOT USE abrasive or chemical cleaners to clean flushometers, they may dull the luster and attack the chrome finish. Use **ONLY** mild soap and water, and then wipe dry with a clean towel or cloth.

When cleaning, protect the exposed flushometer from any splattering of cleaner. Acids and cleaning fluids can discolor or remove chrome plating.

When assistance is required, please contact

Sloan Technical Support at: 1-888-SLOAN-14 (1-888-756-2614).