

INSTALLATION INSTRUCTIONS FOR SLOAN CX MANUAL CLOSET AND URINAL FLUSHOMETERS



Manual Closet Flushometers

- Model CX 158-1.6
- Model CX 158-1.28
- Model CX 158-1.1
- Model CX 154-1.6
- Model CX 154-1.28
- Model CX 154-1.1

Manual Urinal Flushometer

- Model CX 198-0.5
- Model CX 198-0.25
- Model CX 198-0.125

LIMITED WARRANTY

Sloan Valve Company warrants its Flushometer to be made of first class materials, free from defects of material or workmanship under normal use and to perform the service for which they are intended in a thoroughly reliable and efficient manner when properly installed and serviced, for a period of three (3) years (one year for special finishes) from the date of purchase. During this period, Sloan Valve Company will, at its option, repair or replace any part or parts that prove to be thus defective if returned to Sloan Valve Company, at customer's cost, and this shall be the sole remedy available under this warranty. No claims will be allowed for labor, transportation or other incidental costs. This warranty extends only to persons or organizations that purchase Sloan Valve Company's products directly from Sloan Valve Company for purpose of resale. This warranty does not cover the life of batteries.

THERE ARE NO WARRANTIES THAT EXTEND BEYOND THE DESCRIPTION ON THE FACE HEREOF. IN NO EVENT IS SLOAN VALVE COMPANY RESPONSIBLE FOR ANY CONSEQUENTIAL DAMAGES OF ANY MEASURE WHATSOEVER.

PRIOR TO INSTALLATION

This valve is designed for new construction or where there is easily accessed plumbing for the fixture and valve. This valve is designed for a minimum 6-1/2 inch (165 mm) wall space depth. Distance from the center of the valve (inlet or outlet pipe) to the finished surface of the wall can vary from 3-1/4" – 4-1/4" (83 – 108 mm).

Wall plate opening must be 7" (178 mm) wide x 8-1/8" (206 mm) tall. Mud plate is provided and must accompany valve for proper installation. Mud plate is removed after wall is finished.

TOOLS AND ITEMS REQUIRED FOR INSTALLATION (PROVIDED)

- 9/64" hex wrench • Wall plate depth guide • Adjustment tool

TOOLS AND ITEMS REQUIRED FOR INSTALLATION (NOT PROVIDED)

- Smooth-jawed wrench (at least 2") • Philips screwdriver • threaded sweat solder adapter
- approximately 15"-18" pipe

ITEMS INCLUDED (VALVE BOX)

- | | |
|---|---|
| <ol style="list-style-type: none"> 1. Valve Assembly 2. Mud Guard 3. (2) #10-32 x 2 1/2" screws to secure mud guard 4. (2) 1/4" x 20 x 2" screws to remove activation assembly 5. Adjustment tool 6. Installation instructions 7. Holder Tool 8. Adjustable tube 9. Outlet connection 10. Elbow 11. Inlet adapter 12. Vacuum Breaker Assembly V-651A Kit 13. Couplings & gaskets | <ol style="list-style-type: none"> 1. Valve Assembly 2. Mud Guard 3. #10-32 Mud Guard Screws 4. 1/4-20 Activation Assembly Screws 5. Adjustment Tool & Holder 6. Installation Instructions 7. Holder Tool 8. Adjustable Tube 9. Outlet Connection 10. Elbow 11. Inlet Adapter 12. Vacuum Breaker Assembly V-651A Kit 13. Couplings & Gaskets |
|---|---|
-

ITEMS INCLUDED (WALL PLATE BOX)

1. Wall Plate
2. Button & Bracket assembly
3. (2) #10-32 x 3 1/2" screws to secure bracket to valve
- 4 (2) #8-32 x 7/8" screws to secure plate to Bracket
5. Depth setting tool
6. (4) Plunger, screws & locking nut
7. Allen Key 9/64"
8. Installation instructions

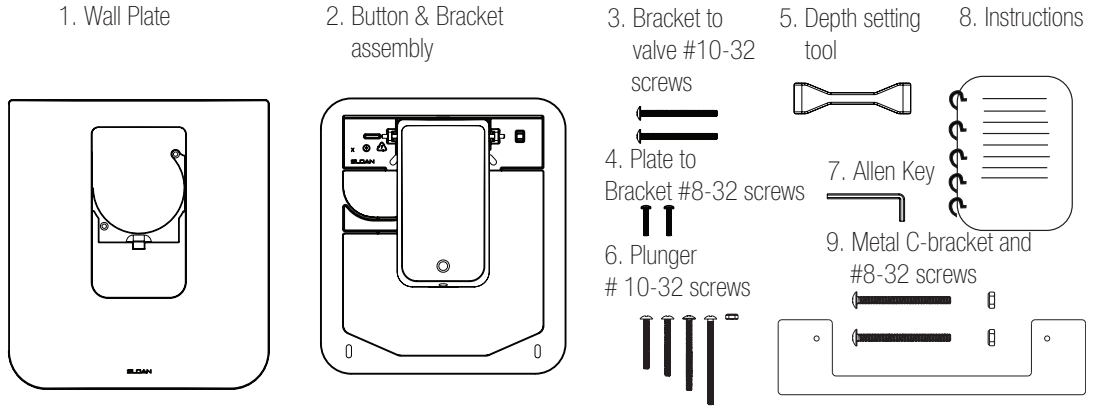

IMPORTANT:

- **INSTALL ALL PLUMBING IN ACCORDANCE WITH APPLICABLE CODES AND REGULATIONS.**
- **WATER SUPPLY LINES MUST BE SIZED TO PROVIDE AN ADEQUATE VOLUME OF WATER FOR EACH FIXTURE.**
- **FLUSH ALL WATER LINES PRIOR TO MAKING CONNECTIONS.**

Sloan's flushometers are designed to operate with 20 to 80 psi (138 to 552 kPa) of water pressure. **THE MINIMUM PRESSURE REQUIRED TO THE VALVE IS DETERMINED BY THE TYPE OF FIXTURE SELECTED.**

Consult fixture manufacturer for minimum pressure requirements. Most high efficiency water closets require a minimum flowing pressure of 25 psi (172 kPa). Many building codes and the ASME A12.19.2 fixture standard list maximum static pressure as 80 PSI (552kPa).

ROUGH-IN URINALS

MODEL 198 URINAL REAR INLET

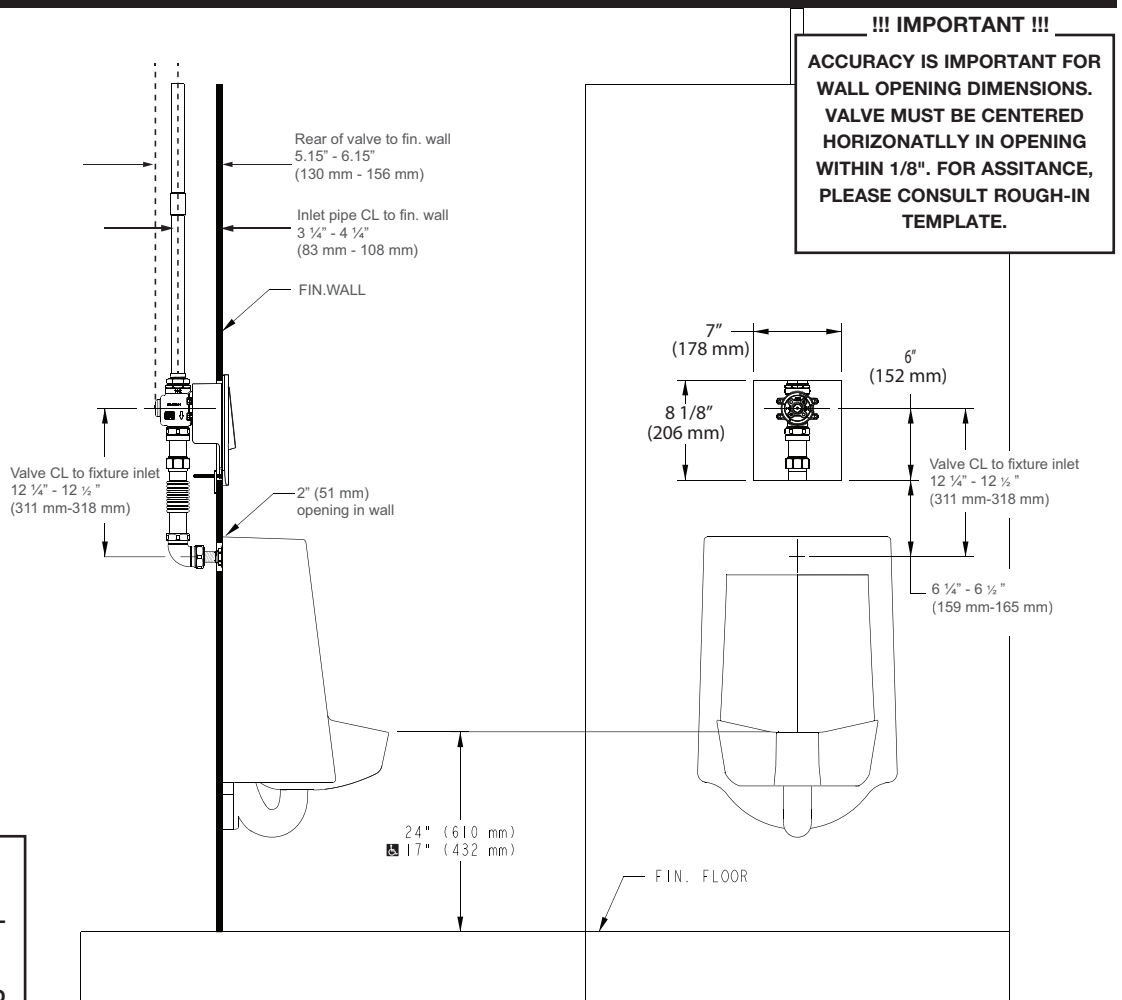

ROUGH-IN CLOSETS

Rough-in for Sloan CX is determined relative to the spud connection for the fixture being used.

MODEL 158 CLOSET WALL HUNG REAR INLET

SIDE VIEW

FRONT VIEW

!!! IMPORTANT !!!

ACCURACY IS IMPORTANT FOR WALL OPENING DIMENSIONS. VALVE MUST BE CENTERED HORIZONATLLY IN OPENING WITHIN 1/8". FOR ASSITANCE, PLEASE CONSULT ROUGH-IN TEMPLATE.

NOTE: If fixture inlet is below rim level, consult floor mount rear inlet rough-in dimensions

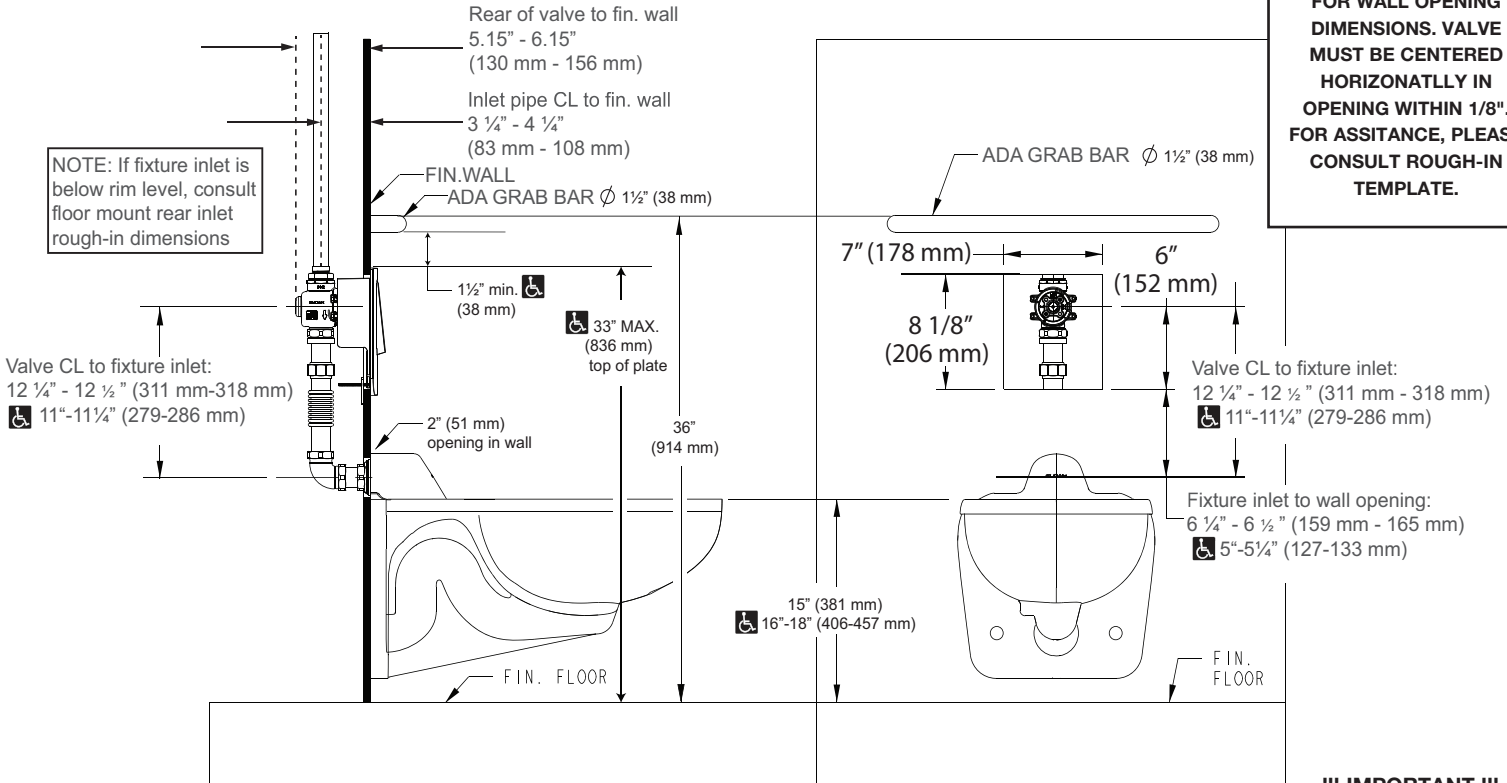

MODEL 154 CLOSE FLOOR MOUNT REAR INLET

SIDE VIEW

FRONT VIEW

!!! IMPORTANT !!!

ACCURACY IS IMPORTANT FOR WALL OPENING DIMENSIONS. VALVE MUST BE CENTERED HORIZONATLLY IN OPENING WITHIN 1/8". FOR ASSITANCE, PLEASE CONSULT ROUGH-IN TEMPLATE.

NOTE: If fixture inlet is above rim level, consult wall hung rear inlet rough-in dimensions

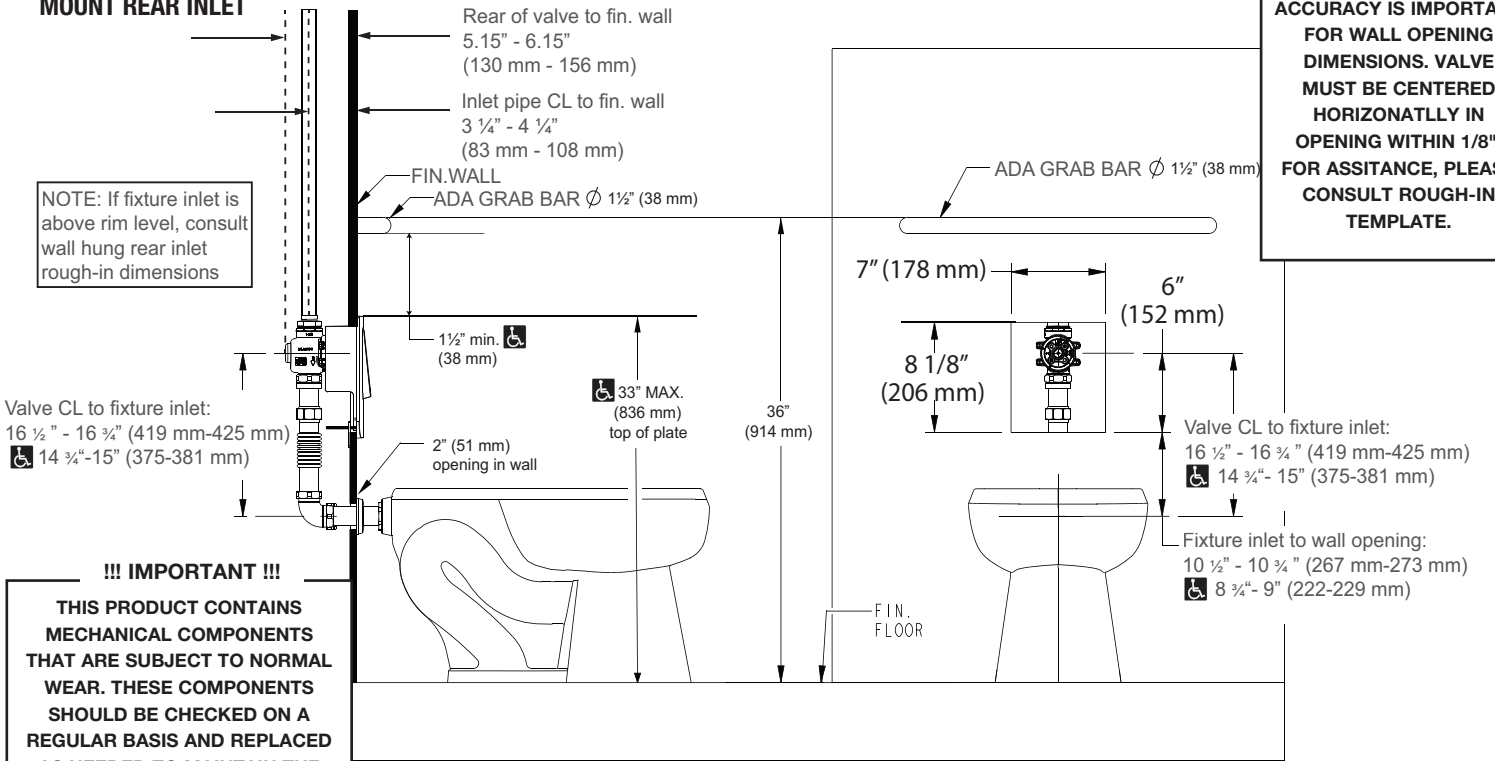

!!! IMPORTANT !!!
THIS PRODUCT CONTAINS MECHANICAL COMPONENTS THAT ARE SUBJECT TO NORMAL WEAR. THESE COMPONENTS SHOULD BE CHECKED ON A REGULAR BASIS AND REPLACED AS NEEDED TO MAINTAIN THE VALVE'S PERFORMANCE.

PARTS OVERVIEW

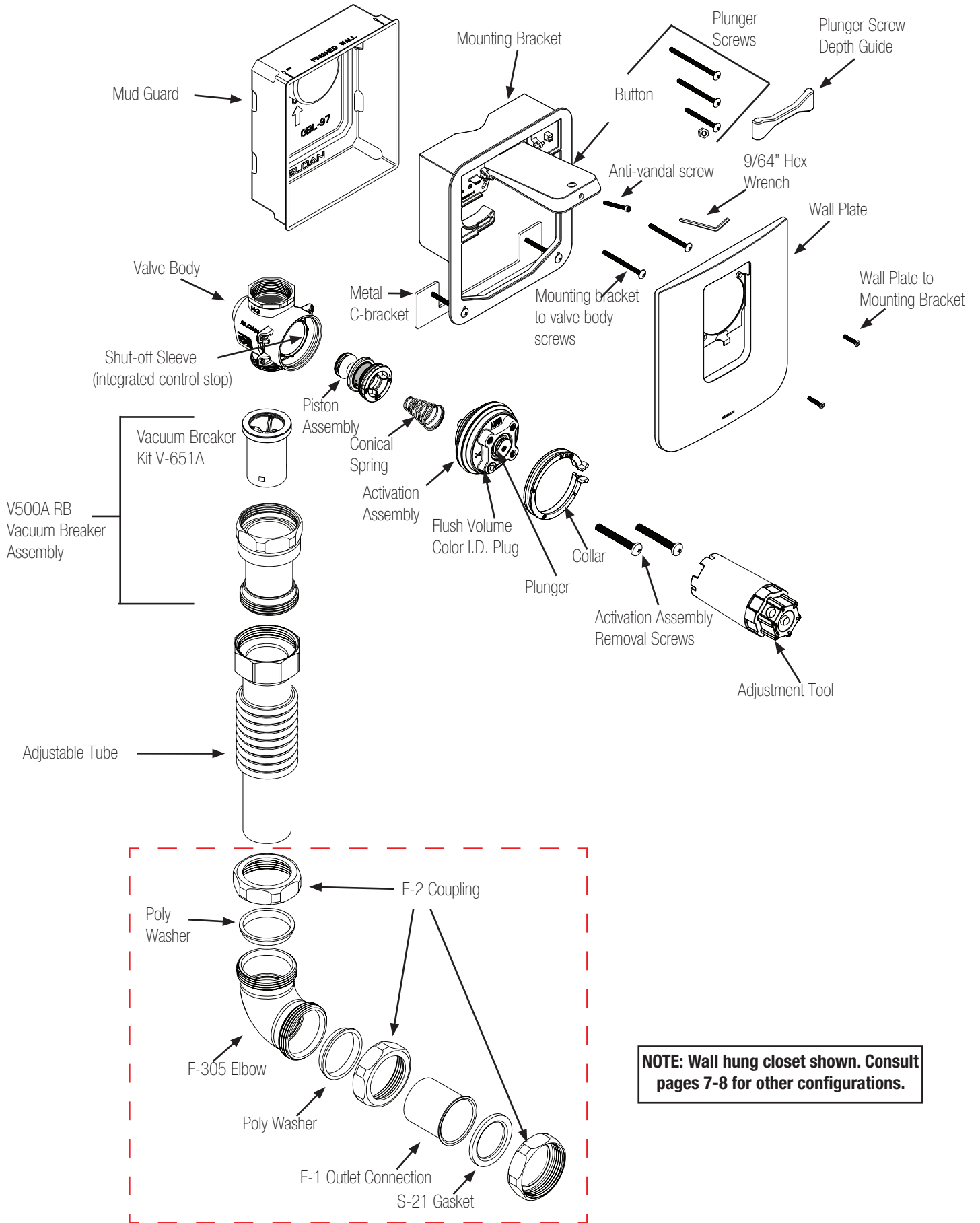

NOTE: Wall hung closet shown. Consult pages 7-8 for other configurations.

INSTALL OPTIONAL SWEAT SOLDER ADAPTER (ONLY IF YOUR SUPPLY PIPE DOES NOT HAVE A MALE THREAD)

A On a 15"-18" length of pipe (not provided), slide threaded sweat adapter (not provided) onto water supply pipe until end of pipe rests against shoulder of adapter. Sweat solder the adapter to pipe (1" copper x 1" NPT fitting).

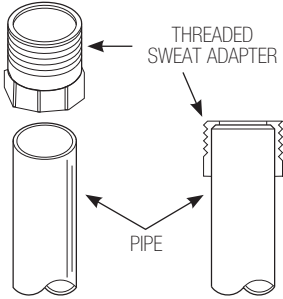

B Remove mud Guard from valve and save for later use- **DO NOT DISCARD**

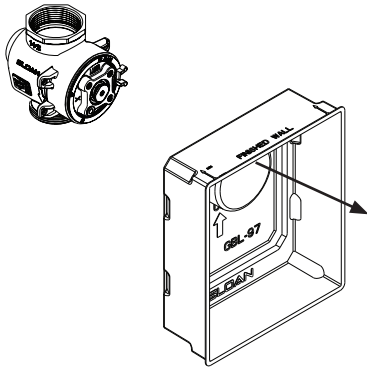

C Insert sweat adapter into 1 1/2" to 1" threaded adapter (provided).

D Connect 1 1/2" to 1" adapter into top of flushometer ("IN")

E Tighten fittings securely into valve body with a fixed jaw wrench.

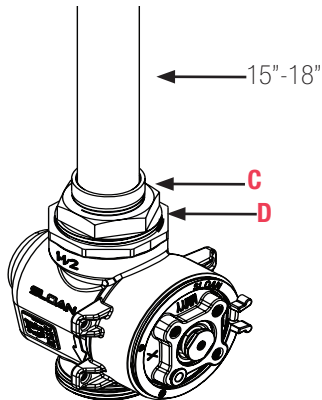

F Using a sweat union (not supplied), connect valve assembly to water supply pipe.

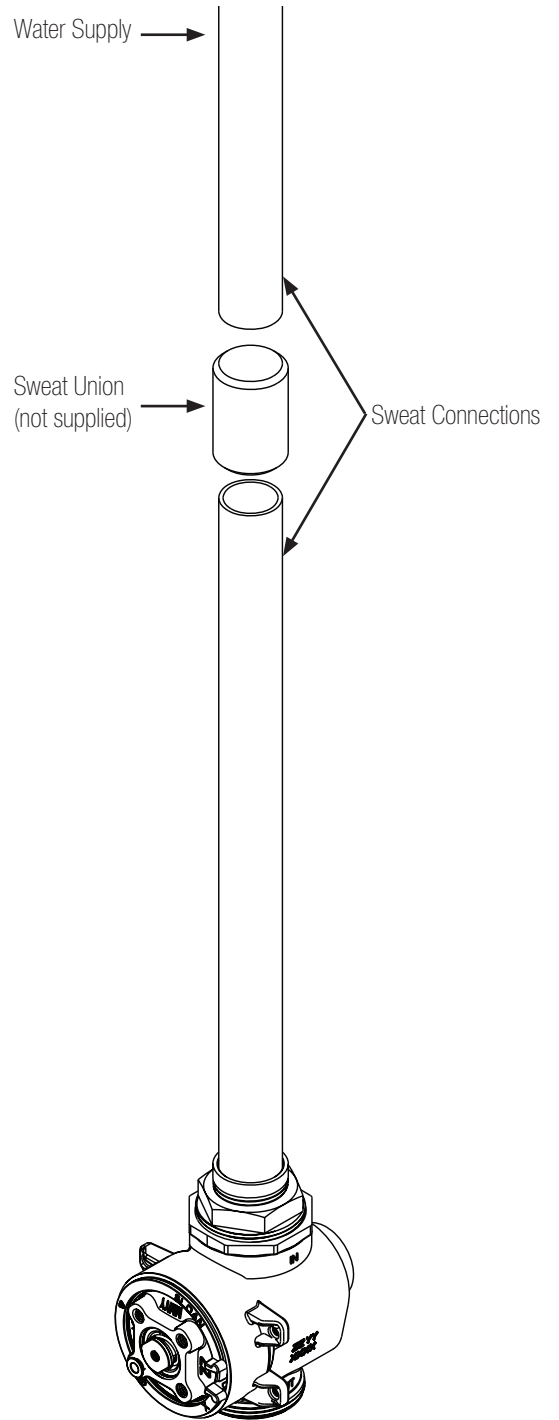

NOTE: PROPERLY BRACE SUPPLY PIPE AFTER SWEATING CONNECTIONS TO PREVENT VALVE MOVEMENT DURING INSTALLATION AND USE SLOAN RECOMMENDS BRACING VALVE WITHIN 6" OF INLET CONNECTION.

MAKING SPUD CONNECTION CONFIGURE ADJUSTABLE TUBE

- A** If needed, trim bottom of adjustable tube using grinding style cut-off tool.
- NOTE: would only be needed for certain ADA water closet installations.
 - Consult rough-in guide (page 2-3)

- B** As needed based on rough-in, pre-bend the adjustable tube to account for side-to-side misalignment of water supply pipe relative to fixture

!!! ATTENTION !!!

Before attempting to cut the adjustable tube, with the plug inserted into the bottom of the tube to prevent crimping, grip the tube outside the corrugated section firmly with hands (not squeezing), flex the tube while pushing together to shorten the length. The same can be applied while pulling outward to lengthen the adjustable tube.

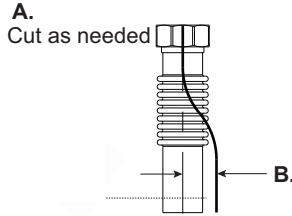

FOR WALL HUNG REAR SPUD FIXTURES (WATER CLOSETS)

- A** Cut F-1 flush connection to length as needed for particular rough-in.
- Consult rough-in (pages 2-3)
- B** Connect F-1 flush connection and adjustable tube to the elbow using coupling and poly washer. **Apply Loctite to tube ends**, insert tube ends into elbow, and tight coupling securely (Do not apply Loctite to coupling threads). Allow Loctite to cure for 24 hours before flushing water through valve. Failure to allow Loctite to cure could result in separation or leaks.

Loctite must cure for 24 hours before turning on water otherwise the Loctite will wash out and joint will leak

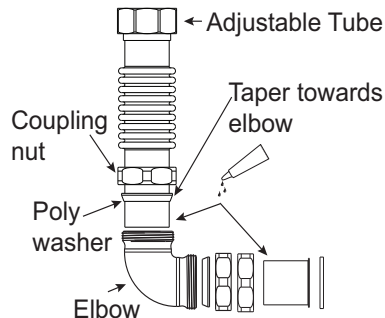

- C** Insert V-651A vacuum breaker kit into vacuum breaker casing. Attach to valve hand tight.
- D** Attach flush connection to vacuum breaker hand tight.

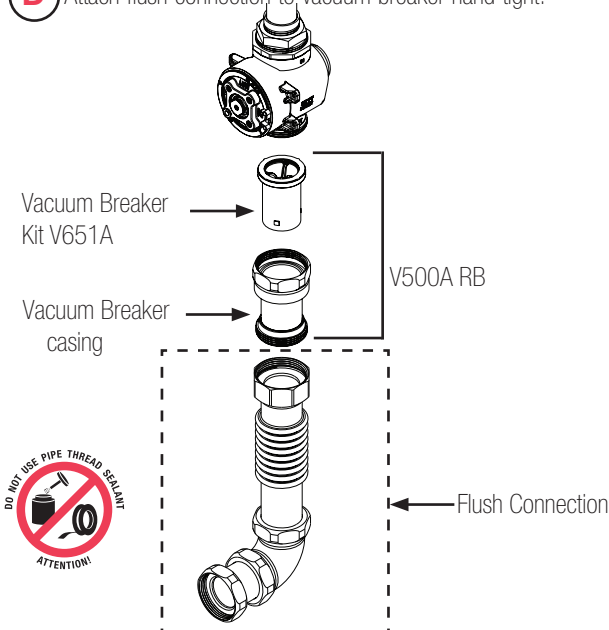

- E** Finish wall. Use supplied mud guard to protect valve during finishing process.
- Use two (2) mounting bracket to valve body screws, if needed, to hold mud guard to valve body

!!! IMPORTANT !!!

Wall plate opening must be 7" (178 mm) wide x 8-1/8" (206 mm) tall. Valve must be centered within opening according to dimensions listed on pages 2 and 3.

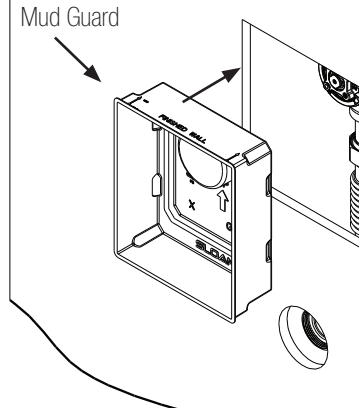

- F** Loosen vacuum breaker assembly to valve and loosen adjustable tube from V500A RB. **Do not** disconnect coupling connections.
- G** Partially mount fixture onto carrier nuts.
- H** Pull flush connection forward through wall.
- I** Make spud connection wrench tight.
- NOTE: Space permitting or chase present, spud connection can be made behind wall.
- J** Push fixture back to wall. Tighten carrier bolts and complete fixture installation.
- K** Re-connect vacuum breaker to valve.

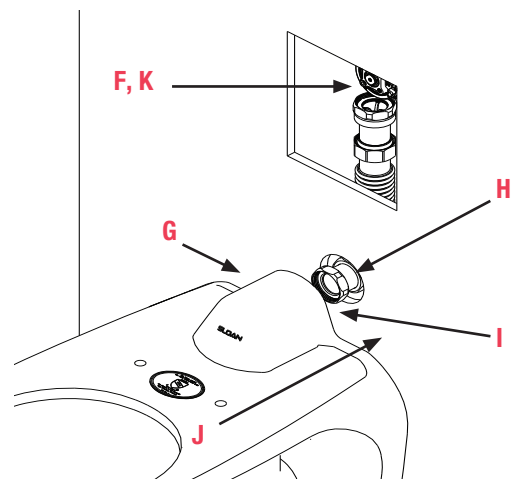

FOR FLOOR MOUNT REAR SPUD FIXTURES (WATER CLOSET)

- A** If needed, trim bottom of adjustable tube using grinding style cut-off tool. • NOTE: would only be needed for certain ADA water closet installations.
• Consult rough-in guide (page 2-3)
- B** As needed based on rough-in, pre-bend the adjustable tube to account for side-to-side misalignment of water supply pipe relative to fixture spud.

!!! ATTENTION !!!

Before attempting to cut the adjustable tube, with the plug inserted into the bottom of the tube to prevent crimping, grip the tube outside the corrugated section firmly with hands (not squeezing), flex the tube while pushing together to shorten the length. The same can be applied while pulling outward to lengthen the adjustable tube.

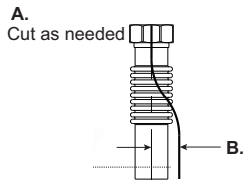

- C** Cut F-1 flush connection to length as needed for particular rough-in.
• Consult rough-in (pages 2-3)
- D** Connect F-1 flush connection and adjustable tube to the elbow using coupling and poly washer. **Apply Loctite to tube ends**, insert tube ends into elbow, and tighten coupling securely (Do not apply Loctite to coupling threads). Allow Loctite to cure for 24 hours before flushing water through valve. Failure to allow Loctite to cure could result in separation or leaks.

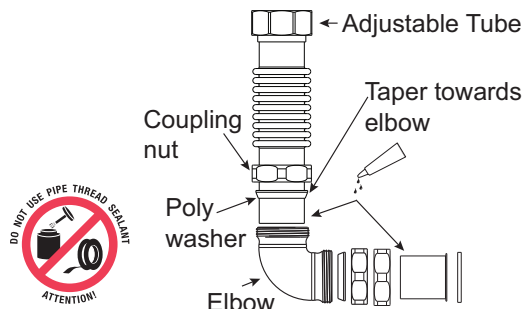

Loctite must cure for 24 hours before turning on water otherwise the Loctite will wash out and joint will leak

- E** Install mud guard. Finish wall.
- F** Mount fixture.
- G** Loosen vacuum breaker to valve. Pull flush connection forward through opening in wall.
- H** Pre-install escutcheon and fittings in the following order:
1. Wall trim plate
 2. Coupling
 3. Friction Ring
 4. Gasket
 5. Escutcheon
- I** Connect coupling (2) to spud, wrench tight.
- J** Slide wall trim plate against wall.
Re-connect vacuum breaker to valve.

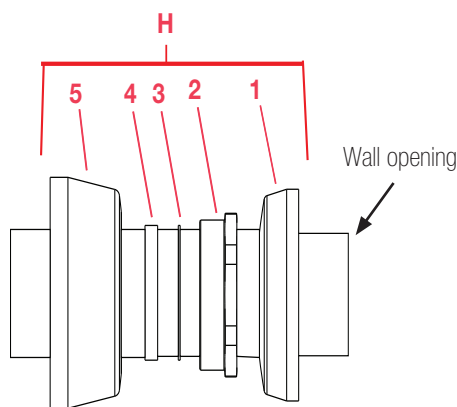
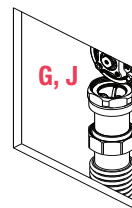
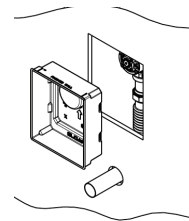

FOR REAR SPUD URINALS

- A** If needed, trim urinal flush tube
- B** Slide 3/4" coupling over urinal flush tube
- C** Thread F-28 brass flange onto urinal flush tube.
Amount of thread engagement will depend on rough-in.
Use provided Loctite to secure F-28 flange in place and to ensure a seal.
- D** **Apply Loctite to adjustable tube end**, insert adjustable tube end into elbow and tighten securely. Do not apply Loctite to coupling threads. Allow Loctite to cure for 24 hours before flushing water through valve. Failure to allow Loctite to cure could result in separation or leaks.
- E** Secure urinal flush tube to elbow using 1-1/2" gasket.

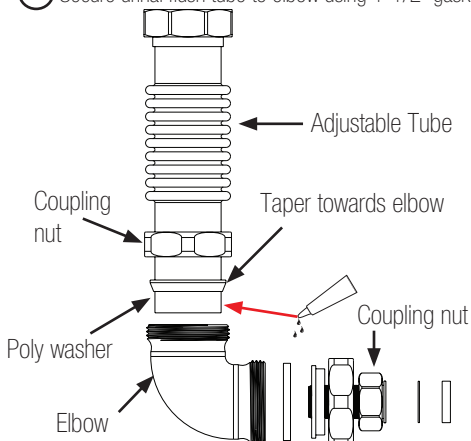
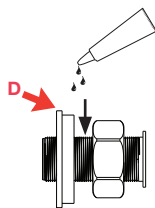
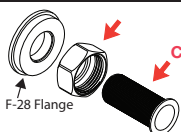

Loctite must cure for 24 hours before turning on water otherwise the Loctite will wash out and joint will leak

- F** Hang urinal on mounting bracket
- G** Loosen vacuum breaker to valve
- H** Make spud connection behind the wall.
- I** Re-connect vacuum breaker to valve.

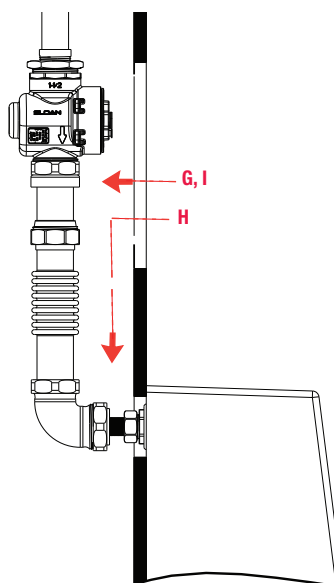

FLUSHING WATER LINES

Note: Valve is shipped with flow adjustment turned off.

- A** Shut off water: use adjustment tool to turn activation assembly fully clockwise.

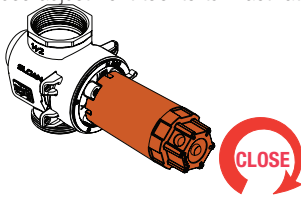

- B** Relieve pressure by pressing plunger. Push in activation assembly.

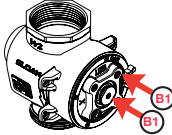

- C** Squeeze tabs on Collar and pull out.

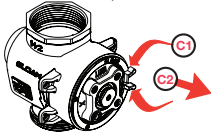

- D** Attached provided 1/4-20 screws to activation assembly. Pull to remove assembly

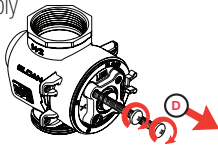

- E** Remove conical spring. Do not discard!

- F** Remove piston assembly by pulling straight out. If unable to grip piston, remove screw from activation assembly and insert into center hole of piston.

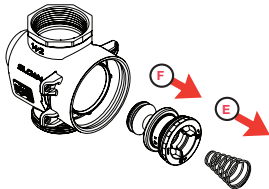

- G** Reinstall activation assembly and press until fully seated. Remove screws.

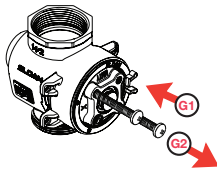

- H** Reinstall Collar. Collar will spin freely in valve body when properly installed.

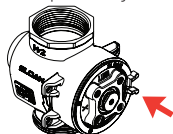

- I** Using adjustment tool, turn activation assembly counter clockwise to open flow of water through the valve.

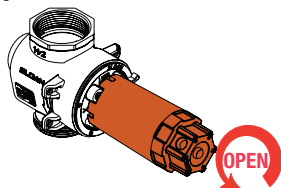

- J** Once lines are flushed clear, turn activation assembly clockwise to shut off water.

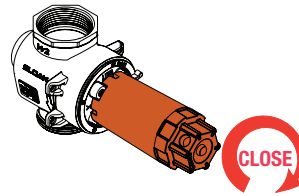

- K** Push in activation assembly.

- L** Squeeze tabs on Collar and pull out.

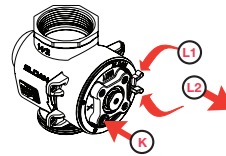

- M** Attach provided screws to activation assembly. Pull to remove.

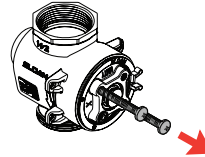

- N** Reinstall piston. Insert smaller sized end first until fully seated.

- O** Reinstall conical spring, small end first, into piston.

- P** Reinstall activation assembly and press until fully seated.

- Q** Reinstall orange collar securely. Collar will spin freely in valve body when properly installed.

- R** Adjust flow rate of valve as described on page 9.

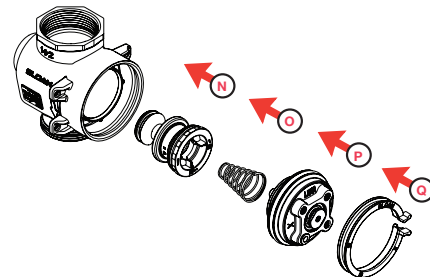

ADJUSTING FLOW

- A** Using adjustment tool, turn activation assembly slowly to adjust flow.
- i. There is approximately 1/8-turn (45°) of free spinning as the activation assembly engages the shut-off sleeve between opening and closing the valve.
 - ii. 1-1/2" socket or wrench can be attached to the adjustment tool or a screwdriver can be passed through the side side holes to provide additional torque.
- B** Push plunger to activate flush. Adjust water flow as needed to clean the fixture.

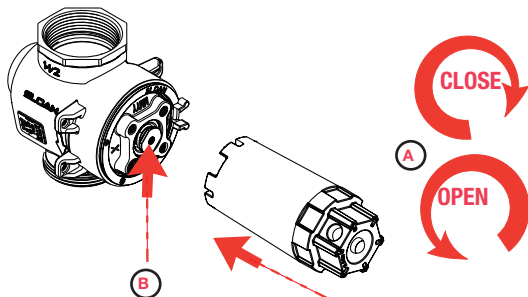

IMPORTANT

THE FLUSHOMETER IS ENGINEERED FOR QUIET OPERATION. EXCESSIVE WATER FLOW CREATES NOISE, WHILE TOO LITTLE WATER FLOW MAY NOT SATISFY THE NEEDS OF THE FIXTURE. PROPER ADJUSTMENT IS MADE WHEN PLUMBING FIXTURE IS CLEANSSED AFTER EACH FLUSH WITHOUT SPLASHING WATER OUT FORM THE LIP AND A QUIET FLUSHING CYCLE IS ACHIEVED.

INSTALL WALL PLATE ASSEMBLY

- A** Loosen set screw with provided 9/64" Allen hex key until button is free to rotate upward. Lock into position.
- B** Remove face plate and set aside
- C** Mount wall bracket to wall, tilting to insert metal C-bracket through wall opening.
- D** Insert #10-32 mounting screws through wall bracket. Attach to top mounting holes on valve body.

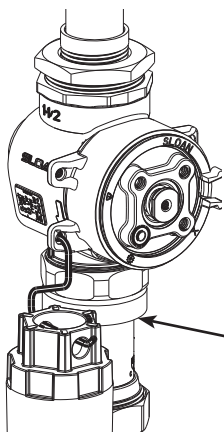
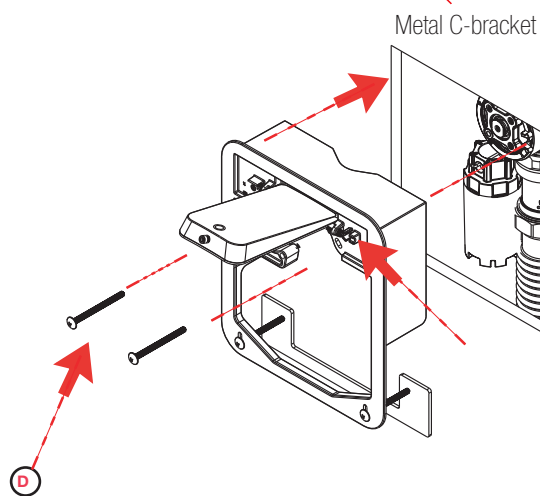
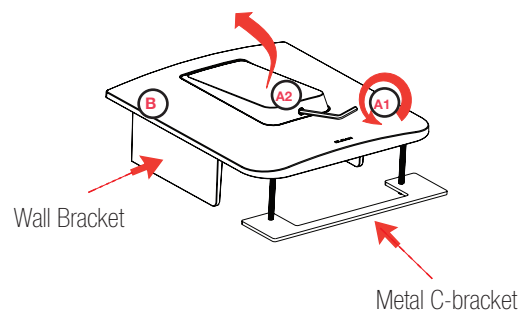

NOTE: If desired, orange flow adjustment tool can be attached to valve assembly using supplied mounting hanger

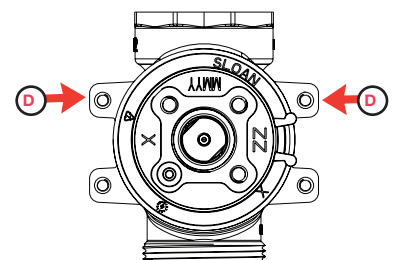

INSTALL WALL PLATE ASSEMBLY (CONT.)

- E** Tighten #8-32 screws at bottom of wall bracket. Metal C-bracket will clamp against wall.

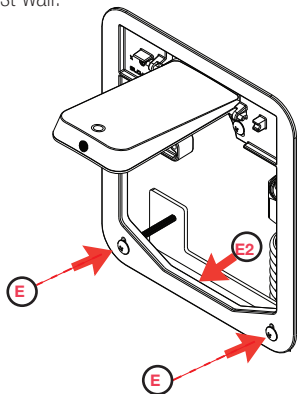

- F** Slide wall plate over button. Button will pass through top of opening.

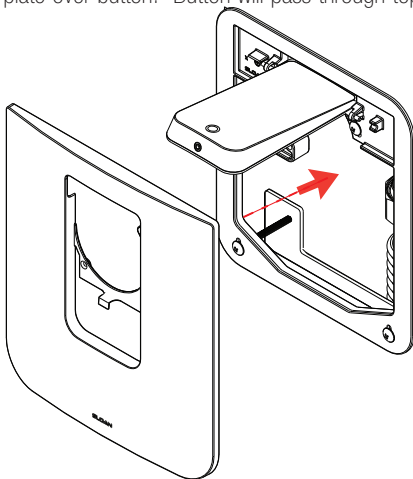

- G** Insert #8-32 wall plate to mounting bracket screws into wall plate. Tighten to secure to wall bracket.

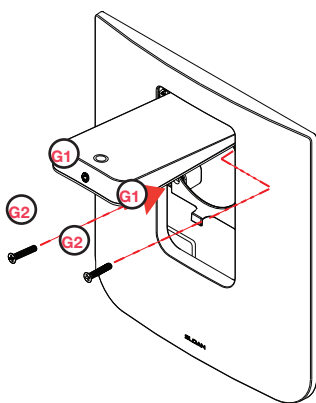

- H** Choose one of three Plunger screws and nut provided and thread into plunger. If Plunger starts rotating, **STOP**. This means the screw has reached the bottom of the hole and overtightening the screw will cause damage to the plunger. Try the next shorter screw included with the product to finish adjustment.

- I** Using depth guide provided, adjust depth of Plunger screw until screw touches depth guide and secure with nut.

- J** Fold down button

- K** Secure set screw using provide Allen key. Button should not be tight against screw attached to Plunger. NOTE: take care when tightening screw - Allen key can scratch finish of the wall plate.

- L** Test flush by pushing button. Make sure button is not pushing screw when in resting position.

IMPORTANT: If button is tight to the screw when at rest, intermittent valve flushing may occur.

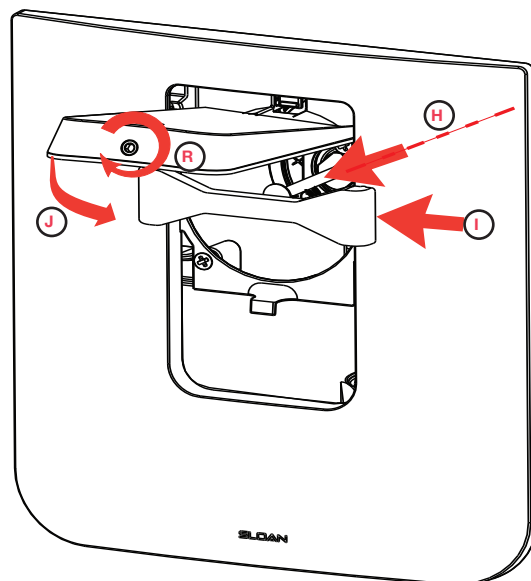

BASIC SERVICING

- A** Open wall plate
- Loosen set screw using 9/64 allen key
 - Lift button until it snaps into the "up" position
- B** Remove wall plate. Loosen two screws, pull forward.
- Note:** water can be shut-off without removing wall plate. Removing wall plate provides more hand room for servicing valve.
- C** Shut off water: use adjustment tool to turn activation assembly fully clockwise.
- D** Relieve pressure by pressing plunger. Push in activation assembly.
- E** Squeeze tabs on Collar and pull out.
- F** Attach provided 1/4-20 screws to activation assembly. Pull to remove assembly.
- G** Remove conical spring. Do not discard!
- H** Remove piston assembly by pulling straight out. If unable to grip piston, remove 1/4-20 screw from activation assembly and insert into center hole of piston.
- I** Reinstall or replace piston. Insert smaller sized end first until fully seated.
- J** Reinstall or replace conical spring, small end first, into piston.
- K** Reinstall or replace activation assembly and press until fully seated.
- L** Reinstall orange safety ring securely. Safety ring will spin freely in valve body when properly installed

NOTE: Using screws attached to activation assembly, pull activation assembly forward to ensure proper alignment.

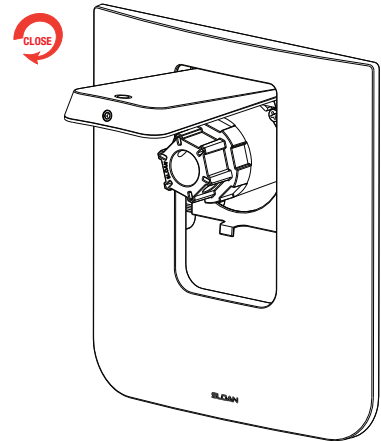
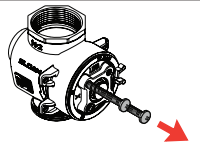

- M** Turn on water: use adjustment tool to turn activation assembly counter clockwise. See "Adjusting Flow" section for further details.

TROUBLESHOOTING GUIDE

1. Flushometer does not function (no water/flush).

- A. Ensure water supply to valve is turned on.
- B. Shut off sleeve is in closed position. Turn counterclockwise to open water flow. NOTE: There is approximately 1/8-turn (45°) of free spinning as the activation assembly engages the shut-off sleeve between opening and closing the valve.
- C. Plunger screw is not adjusted properly. Adjust screw using depth guide. NOTE: Activation button should be held one (1) second for optimal performance.

2. Volume of water is not sufficient to evacuate the bowl.

- A. Shut off sleeve is not open wide enough. Adjust shut off sleeve for desired delivery of water volume.
- B. Urinal piston parts installed in a Closet flushometer. Replace piston with proper Closet piston (1.6 gpf/6.0 Lpf or 1.28 gpf/4.8 Lpf)
- C. Water supply volume or pressure is inadequate (low). If the fixture does not siphon or evacuate the bowl, steps must be taken to increase the water supply pressure and/or volume. Contact the fixture manufacturer for minimum water supply requirements of the fixture.
- D. Plunger screw is not adjusted properly. Adjust screw using depth guide. NOTE: Activation button should be held one (1) second for optimal performance.

3. Flushometer closes off immediately.

- A. Urinal piston parts installed in a Closet flushometer. Replace piston with proper Closet piston (1.6 gpf/6.0 Lpf or 1.28/4.8 Lpf).
- B. Piston lip seal may be damaged or worn. Replace with new correct gpf/Lpf piston.
- C. Plunger screw not set properly. Adjust screw using depth guide.

4. Length of flush is too short (Short Flush).

- A. Incorrect piston is installed in Flushometer; for instance, Urinal assembly inside a Closet Flushometer, or High Efficiency assembly inside a higher consumption fixture. Determine the flush volume required by the fixture and replace with proper gpf/Lpf piston. Use valve label and markings on fixture for reference.
- B. Piston lip seal may be damaged or worn. Replace with new correct gpf/Lpf piston.
- C. Plunger screw is not adjusted properly. Adjust screw using depth guide.

5. Length of flush is too long (Long Flush) or continuous.

- A. Metering bypass hole in piston is clogged. Remove the piston from the valve, slide o ring off filter, and wash under clean running water. Reposition o-ring before reinstalling piston. Replace piston if cleaning does not correct the problem.
- B. Supply line water pressure has dropped and is not sufficient to close the valve. Close shut off sleeve until pressure is restored. NOTE: under some conditions, opening the shut-off sleeve can correct the force imbalance and cause the valve to close.
- D. Piston is damaged. Replace with new proper gpf/Lpf piston
- E. Incorrect Piston is installed in Flushometer; for instance, Closet assembly inside a Urinal flushometer. Determine the flush volume required by the fixture and replace piston. Use valve label and markings on fixture for reference.

6. Chattering noise is heard during flush.

- A. Reduce flow pressure by turning shut off sleeve clockwise.
- B. Air trapped inside the valve and/or supply pipe. Air takes time-both count of flushes and actual duration - to be fully removed.

CARE AND CLEANING

DO NOT use abrasive or chemical cleaners (including chlorine bleach) to clean Flushometers that may dull the luster and attack the chrome or special decorative finishes. Use **ONLY** mild soap and water, then wipe dry with clean cloth or towel. While cleaning the bathroom tile, protect the Flushometer from any splattering of cleaner. Acids and cleaning fluids will discolor or remove chrome plating.

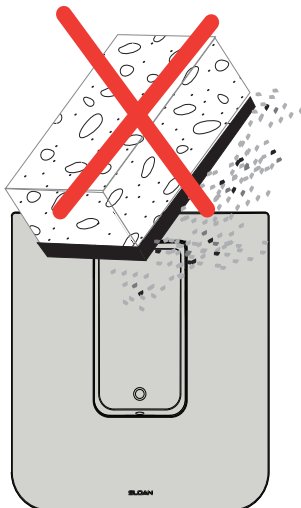

VALVE ASSEMBLY GUIDE

Item No.	Code No.	Description
1	See Maintenance Guide	Piston Assembly
2	See Table	Activation Assembly (see below)
3	3340011	Safety Collar
4	3340012	Sloan CX adjustment

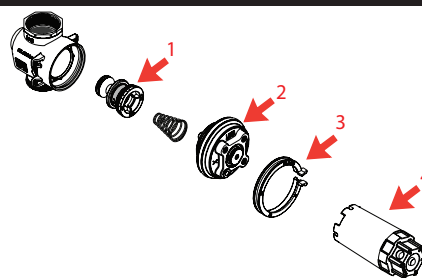

For a complete list of Sloan CX repair parts, consult Repair Parts & Maintenance Guide

ACTIVATION ASSEMBLY SELECTION GUIDE

Code No.	Description	Plug Color*
3340048	1.6 gpf/6.0 Lpf closet activation assembly	Green
3340049	1.28 gpf/4.8 Lpf closet activation assembly	Purple
3340057	1.1 gpf/4.2 Lpf closet activation assembly	Grey
3340051	0.5 gpf/1.9 Lpf urinal activation assembly	Red
3340052	0.25 gpf/1.0 Lpf urinal activation assembly	Burgundy
33400005	0.125 gpf/0.5 Lpf urinal activation assembly †	Not Applicable

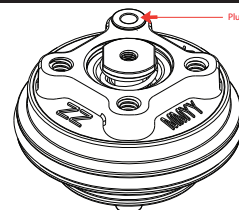

* Colors may differ. Consult factory to confirm you have the correct activation assembly.
 † 0.125 gpf/0.5 Lpf urinal activation assembly has a silver color. Other models are a brass/yellow color.

IN ORDER FOR THE WATER CLOSET AND THE URINAL TO PERFORM PROPERLY FOR ITS INTENDED USE, YOU MUST FOLLOW THESE INSTRUCTIONS:

- A. IDENTIFY YOUR FLUSHOMETER MODEL NO.
- B. CHECK FOR THE WATER COTION LABEL ATTACHED TO THE FLUSHOMETER AND FIXTURE, ENSURING THEY MATCH
- C. REFER TO SPECIFIC FLUSHOMETER SECTION IN GUIDE FOR APPROPRIATE REPLACEMENT PART NO.

FLUSH CONNECTION PARTS

Item	Code No.	Description
1	3323182	V-651A Vacuum Breaker Repair Kit
2	0323279	V-500A RB Vacuum Breaker Assembly
3	33060011	F227A Repl kit, adj. tube 6.5" long (Models 158 & 198)
	33060012	F228A Repl kit, adj. tube 10.5" long (Model 154)
4	0306395	CX Poly Washer Coupling (set of 2)
5	0306392PK	F-305 CX Elbow for CX Poly Washer
6	0306091	F-2-A 1-1/2" Coupling with S-21 Gasket
7	0306031PO	F-1 1 1/2" (38 mm) Flanged outlet tube RB, 6"
8	0396119PK	F-101 CP Tube Outlet 1 1/2" x 10 1/2"
9	0306237PK	F-7 Flange 1 1/2" x 3" w/Prongs, CP*
10	0306146PK	F-5-A 1-1/2" Spud Coupling Assembly CP*
11	0306396	CX Urinal flush connection repair kit

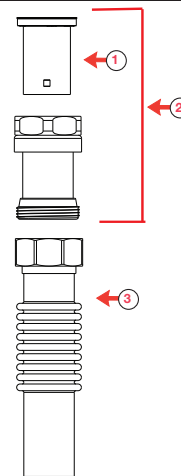

* Consult factory for alternate finish options

Manufactured in the U.S.A by Sloan Valve Company under one or more of the following patents: U.S. Patents. 5,295,655; 5,542,718; 5,558,120; 5,564,460; 5,730,415; 5,865,420; 5,887,848; 5,967,182. Other Patents Pending.

Bak-Chek®, Para-flo®, PERMEX®, Turbo-Flo®

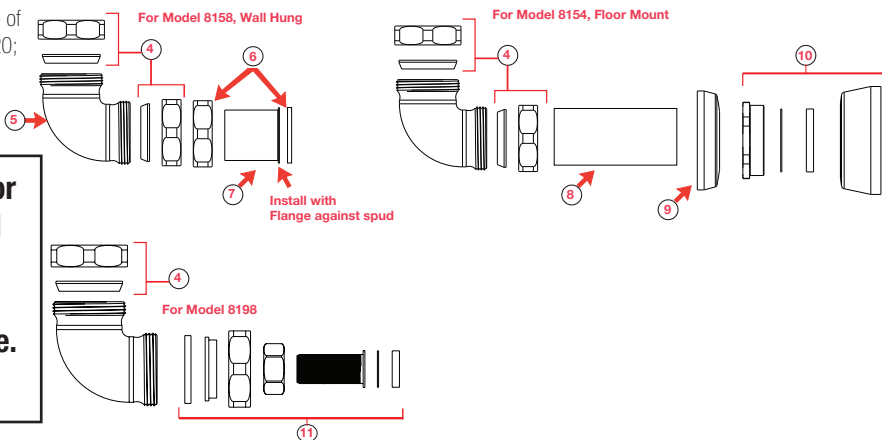

For complete listing of items available for repair, please consult Maintenance and Repair Guide.

**Contact Technical Support for assistance.
 1.888.756.2614 or 1.888.SLOAN14**

The information contained in this document is subject to change without notice.

SLOAN VALVE COMPANY • 10500 SEYMOUR AVENUE • FRANKLIN PARK, IL 60131

Phone: 1.800.982.5839 or 1.847.671.4300 • Fax: 1.800.447.8329 or 1.847.671.4380 • sloan.com