

**ITEM 10. FLEX TUBE DIAPHRAGM KIT**

Code No.	Part No.	Description	Regulator Color *
3325003	EBV-1023-A	Urinal-0.5 gpf/1.9 Lpf	GREEN
3325000	EBV-1022-A	Urinal-1.0 gpf/3.8 Lpf †	GREEN
3325153	EBV-1024-A	Closet-1.28 gpf/4.8 Lpf †	GREEN
3325152	EBV-1020-A	Closet-1.6 gpf/6.0 Lpf	GREEN
3325014	EBV-1021A	closet-2.4 gpf/9.0 Lpf	BLUE

\* Color of regulator to be used with flex tube diaphragm to obtain the listed flush volume.

A 1.0 gpf (3.8 Lpf) Urinal kit can be converted to a 1.5 gpf (5.7 Lpf) Urinal by replacing the Green Regulator with the supplied Black Regulator.

A 1.6 gpf (6.0 Lpf) Closet kit can be converted to a 3.5 gpf (13.2 Lpf) Closet by replacing the Green Regulator with the supplied White Regulator.

**ITEM 10. REGULATORS**

The flush volume of the flex tube diaphragm kit is controlled by the regulator. Regulators are identified by color. Some flex tube diaphragm kits are supplied with multiple regulators. The installer must make sure the proper regulator is used when installing the flex tube diaphragm kit.

**REGULATOR (SOLD 6 PER PACKAGE)**

Code No.	Part No.	Description	Regulator Color
5325122	EBV-95	Urinal-0.5 gpf/1.9 Lpf	GREEN
5325122	EBV-95	Urinal-1.0 gpf/3.8 Lpf	GREEN
5325122	EBV-95	Closet-1.6 gpf/6.0 Lpf	GREEN
5325128	EBV-101	Closet-2.4 gpf/9.0 Lpf	BLUE

**FLEX TUBE DIAPHRAGM ASSEMBLY**

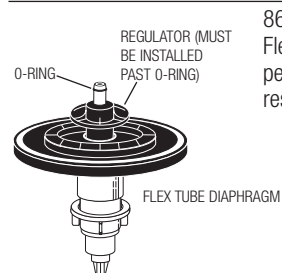

8603 Valve Models Feature Sloan's Exclusive Flex Tube Diaphragm™ for the ultimate in valve performance, reliability and Chloramine resistance.

**PARTS LIST**

Item No.	Part No.	Description
1.	†	A1 & A2 RB Valve Body Sub-Assembly w/ 2 1/16" Tail
2.	H-730-A	1" (25 mm) Wheel Handle Bak-Chek® Control Stop
3.	†	Push Button Actuator Assembly
4.	A-1013-A	RB Concealed Handle Cap Kit
5.	V-500-AA	1 ½" (38 mm) x 10-1/2" (267 mm) VB Assembly RB
6.	F2-AA	1-1/2" (38 mm) Slip Joint Couplings (two per package)
7.	F-21	RB 1-1/2" (38 mm) EL Double Male Slip Joint
8.	F-100	1-1/2" (38 mm) x 3-1/4" Flared End Flush Connection
9.	F-2A	1-1/2" (38 mm) Coupling with S-21 Gasket
10.	<b>SEE CHART NEXT PAGE</b>	Flex Tube Diaphragm Assembly
11.	V-551-A	Vacuum Breaker Repair Kit

**SEE SLIP JOINT GASKETS AND RINGS TABLE ON NEXT PAGE**

† Part number varies with valve model variation; consult factory.

**BATTERY REPLACEMENT**

When required, replace batteries with four (4) Alkaline AA-Size Batteries.

**Note: Water does not have to be turned off to replace batteries.**

Loosen the two (2) Screws on top of unit. Remove the complete Cover Assembly. Lift the Module from its Plate. Unplug the Electrical Connector from Battery Compartment Cover. Loosen the Retaining Screw on Battery Compartment Cover and remove Battery Compartment Cover. Install four (4) Alkaline AA-Size Batteries **exactly** as illustrated.

Install Battery Compartment Cover and secure with Retaining Screw. Make certain that Battery Compartment Cover is fully compressed against Gasket to provide a seal; **Do Not** overtighten. Plug the Electrical Connector into the Battery Compartment Cover. Reinstall the Module onto the Plate. Reinstall the complete Cover Assembly onto the Plate. Tighten the two (2) Screws on top of the unit.

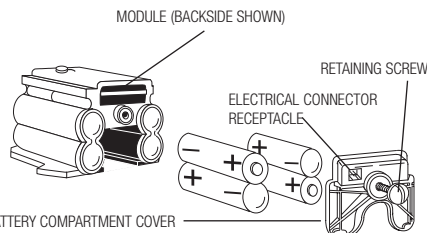
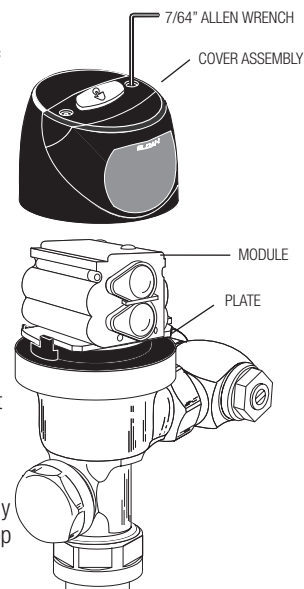

**ITEM 19D. SLIP JOINT GASKETS AND RINGS**

Size	Code No.	Part No.	Description
1-1/2"	5306058	F-3	Red Friction Ring
	5322001	VB-F-5	Black Slip Joint Gasket
	0319086/5319086	S-30	Flexible Seat
1-1/2"	0319079	S-21	Rigid Seat (rubber over brass)
	0396062	F-105	Slip Joint Gasket – Rigid
1"	5306056	F-3	Red Friction Ring
	5306115	F-5	Black Slip Joint Gasket

**TROUBLESHOOTING AND MAINTAINING THE SLOAN OPTIMA PLUS® FLUSHOMETER**

**IMPORTANT:** This product contains mechanical and/or electrical components that are subject to normal wear. These components should be checked on a regular basis and replaced as needed to maintain the valve's performance.

Never open Control Stop to where the flow from the valve exceeds the flow capability of the fixture. In the event of a valve failure, the fixture must be able to accommodate a continuous flow from the valve.

**ATTENTION INSTALLERS:** With the exception of the control stop inlet, DO NOT USE pipe sealant or plumbing grease on any valve component or coupling! To protect the chrome or special finish of Sloan flushometers, DO NOT USE toothed tools to install or service these valves. Use our A-50 Super-Wrench™ or other smooth-jawed wrench to secure couplings. Regulations for low consumption fixtures (1.6 gpf/6.0 Lpf closets and 1.0 gpf/3.8 Lpf urinals) prohibit use of higher flush volumes.

**1. Valve does not flush.**

- A. Check Pushbutton Connection.
- B. Is the LED on the pushbutton Red? Unit is in Lock-out.
- C. Does Override flush the unit? If yes, Unit is reset.
- D. Low Battery indicator (2 quick flashes every 4 seconds).
- E. Battery needs replacement (4 quick flashes every 4 seconds) unit will not flush.

**2. Valve does not flush but makes clicking sound.**

- A. No water is being supplied to the valve. Make certain that water supply is turned on and control is open.
- B. Problem with solenoid. Replace solenoid.

**3. Valve does not shut off.**

- A. Bypass Orifice in Diaphragm is clogged with dirt or debris, or Bypass is clogged by an invisible gelatinous film due to "over-treated" water. Remove Flex Tube Diaphragm and wash under running water.

**Note:** Size of orifice in the by-pass is of utmost importance for the proper metering of water by the valve. **DO NOT ENLARGE OR DAMAGE THIS ORIFICE.** Replace flex tube diaphragm if cleaning does not correct the problem.

- B. Dirt or debris fouling Stem or Flex Tube Diaphragm. Remove Flex Tube Diaphragm and wash under running water.
- C. O-ring on Stem of Flex Tube Diaphragm is damaged or worn. Replace O-ring if necessary.
- D. Problem with Electronic Sensor Module; replace Sensor Module.

**4. Valve does not shut off.**

- A. Bypass Orifice in Diaphragm is clogged with dirt or debris, or Bypass is clogged by an invisible gelatinous film due to "over-treated" water. Remove Flex Tube Diaphragm and wash under running water.

**Note:** Size of orifice in the by-pass is of utmost importance for the proper metering of water by the valve. **DO NOT ENLARGE OR DAMAGE THIS ORIFICE.** Replace flex tube diaphragm if cleaning does not correct the problem.

- B. Dirt or debris fouling Stem or Flex Tube Diaphragm. Remove Flex Tube Diaphragm and wash under running water.
- C. O-ring on Stem of Flex Tube Diaphragm is damaged or worn. Replace O-ring if necessary.
- D. Problem with Electronic Sensor Module; replace Sensor Module.

**5. Not enough water to fixture.**

- A. Wrong Flush Volume Regulator installed in Flex Tube Diaphragm Kit. Install the correct Regulator.
- B. Wrong Optima Plus® Diaphragm kit installed; i.e., 1 gpf. urinal installed on 3.5 gal. closet fixture. Replace with proper Optima Plus diaphragm kit.
- C. Enlarged Bypass in Diaphragm. Replace Flex Tube Diaphragm.
- D. Control Stop not adjusted properly. Readjust Control Stop.
- E. Inadequate volume or pressure at supply. Increase water pressure or supply (flow) to valve. Consult factory for assistance.
- F. Head not securely tightened on flushometer body. Tighten using strap wrench.

**6. Too much water to fixture.**

- A. Wrong Flush Volume Regulator installed in Flex Tube Diaphragm Kit. Install the correct Regulator.
- B. Control Stop not adjusted properly. Readjust Control Stop.
- C. Wrong Diaphragm kit installed; i.e., 3.5 gpf. closet installed on 0.5 gal. urinal fixture. Replace with proper Optima Plus Diaphragm kit.
- D. Dirt in Diaphragm Bypass. Clean under running water or replace Flex Tube Diaphragm.

**SETTING THE PROGRAM**

1. Press and hold override Button. Continue holding the button until the desired program is reached.
2. After about 5 seconds, the LED will turn on for 3 seconds indicating the start of the program section period.
3. LED will blink in 2 second intervals indicating the program.
4. Count the blinks until the desired program number, then release the button. For example, if you want program #3, release the button after the LED blinks for the third time.
5. After the button is released, the LED display will blink indicating which program is selected.
6. Unit comes with program #1 as default program.

**PROGRAM**

1. Release button after 1st blink: 2 activations in a 5 minute window with a lockout of 15 minutes (default program).
2. Release button after second blink: 2 activations in a 5 minute window with a lockout of 30 minutes.
3. Release button after 3rd blink: 2 activations in a 5 minute window with a lockout of 45 minutes.
4. Release button after 4th blink: 2 activations in a 5 minute window with a lockout of 60 minutes.
5. Release button after 5th blink: 1 activation with a backside delay of 60 seconds/no lockout.
6. Check which program is running. Press and release override button, flush should happen right away, then LED will blink the number of corresponding program number.

**CARE OF CHROME AND SPECIAL FINISHES**

**DO NOT USE** abrasive or chemical cleaners to clean flushometers as they may dull the luster and attack the chrome or special decorative finishes. Use **ONLY** soap and water, then wipe dry with clean cloth or towel.

While cleaning the bathroom tile, the flushometer should be protected from any splattering of cleaner. Acids and cleaning fluids can discolor or remove chrome plating.