



OWNER'S MANUAL

VACCUM MACHINE

600A

IMPORTANT SAFETY INSTRUCTIONS

SAVE THESE INSTRUCTIONS



This symbol points out important safety instructions which, if not followed, could endanger the personal safety and/or property of yourself and others. Read and follow all instructions in this manual before attempting to operate your machine.

Failure to comply with these instructions may result in personal injury.

General Operation

- Read, understand, and follow all instructions in the manual and on the machine before starting. Keep this manual in a safe place for further and regular reference and for ordering replacement parts.
- Only allow responsible individuals familiar with the instructions to operate the machine. Be sure to know controls and how to stop the machine quickly.
- Never put your hands near moving parts.
- Only allow qualified individuals for the maintenance of your machine.
- Remove all obstacles, which may interfere with the machine functions.
- Clear the work area such as electrical wires, buckets, knives etc.
- Be sure that everyone else is clear of your work area before operating the machine.
- Do not sit nor stand on the machine.
- Always turn off the machine after your work is done. Never leave a running machine unattended.
- Always disconnect and wait till the machine has cooled before attempting any maintenance.
- Do not wear loose fitting clothes or jewelry as they may get caught in moving parts of the machine.
- Always wear security shoes, to prevent injury caused by moving the machine or objects falling from the machine.
- Never exceed the time limit to seal, which is recommended by the manufacturer. This is to avoid any damage that may be caused to the sealing bars and to eliminate the risk of fire in the machine. Thus avoiding corporal burns.
- Never touch the sealing bars after they have been used, this will avoid corporal burns. Wait a few minutes to let the machine cool down before touching.
- Always make sure that the sealing bars are well installed in their "Guide Blocks" before starting a cycle.
- Never incline the machine more than 30 degrees, it may tip over and hurt someone seriously.
- Work only in daylight or good artificial light.

Do not operate the machine while under the influence of alcohol or drugs!

Service

- Use proper containers when draining the oil. Do not use food or beverage containers that may mislead someone into drinking from them. Properly dispose of the containers, or store in a safe place immediately following the draining of the oil.
- Prior to disposal, determine the proper method to dispose of waste from your local office of Environmental Protection Agency. Recycling centers are established to properly dispose of materials in an environmentally safe fashion.

Do not pour oil or other fluids into the ground, down a drain or into a body of water.



Warning-Your responsibility:

This machine should only be operated by personal who can read, understand and respect warnings and instructions regarding this machine in the owners manual. Save these instructions for future reference.

VACUUM PACKAGING MACHINE

MODEL 600A

(MC-40 SIPROMAC)

GENERAL TABLE OF CONTENTS

I OPERATION INSTRUCTIONS

II MECHANICAL

- A- Front view general assembly drawing
- B- Rear view general assembly drawing
- C- Cover adjustment procedure
- D- Central shaft assembly drawing
- E- Seal bar assembly drawings
(twin seal)
- F- Seal bar assembly drawings
(electrical bag cut option)
- G- Seal bar assembly drawings
(top and bottom sealing option)
- H- Gas injection kit installation drawing
(gas injection option)

III ELECTRICAL

- A- Electrical drawings

IV PNEUMATIC

- A- Pneumatic drawing

VACUUM PACKAGING MACHINES

OPERATION INSTRUCTIONS

TABLE OF CONTENTS

1. Setting up the machine
2. Electrical connection
3. Operation
 - 3.1 Working principles
 - 3.2 Special packaging
 - 3.2.1 Gas flushing
 - 3.2.2 Top and bottom sealing (bi-active)
 - 3.2.2 3.2.3 Electrical bag cut
 - 3.3 Setting of digital controls
 - 3.4 Daily cleaning
4. Trouble shooting
 - 4.1 Failure during a packaging cycle
 - 4.2 Insufficient vacuum
 - 4.2.1 Leakage in the bag
 - 4.2.2 No leakage in the bag
 - 4.2.3 Insufficient vacuum in the chamber
 - 4.3 Faulty seal
 - 4.3.1 Insufficient seal
 - 4.3.2 No seal
 - 4.3.3 Permanent sealing current
 - 4.3.4 Seal does not stick
 - 4.4 Fault in the valves
 - 4.5 Control board failure
5. Regular maintenance

2010-08-30

SIPROMAC INC.

VACUUM PACKAGING MACHINES

1. SETTING UP THE MACHINE:

Before choosing the site for the machine, please consider that you will also need room for packaged and non-packaged products apart from the space needed for the machine itself.

Keep in mind that the machine must not be set up upon uneven ground. Especially with mobile models, the weight of the pump might then cause warping of the machine. Then the lid will not fit correctly.

Before starting to work, check the oil view glass on the pump, if there is a sufficient quantity of oil in the pump. Never use oil other than recommended by the producer. Never exceed maximum quantity of oil indicated, when adding or changing oil. Verify weekly.

Normal ambient temperature for the vacuum pump is between 10 to 70°C. For temperature below 10°C; it is recommended to use synthetic oil. Please consult factory and pump manufacturer manual for more information or when ambient temperature are outside normal limits

2. ELECTRICAL CONNECTION:

Electrical connections must be made by qualified personnel. This person must make sure that the electrical entries corresponds to the proper voltage and amperage of the machine. **GROUNDING INSTRUCTIONS:** This appliance must be connected to a grounded, metal, permanent wiring system; or an equipment-grounding conductor must be run with the circuit conductors and connected to the equipment-grounding terminal or lead on the appliance. A qualified electrician should be consulted if there is any doubt as to whether an outlet box is properly grounded.

All vacuum machines are supplied with an electrical schematic drawing. An important step in connecting the machine is to make sure that the pump turns in its correct rotation.



The pump should not rotate more than 3 to 4 seconds in the wrong rotation or it may cause serious damage. The proper rotation is indicated by an arrow on the pump motor.

3. OPERATION:

3.1 Working principles:

A vacuum packaging cycle is made of 3 stages. First the vacuum is made, the air is completely taken out of the chamber and from bag containing the product. (See figure 1). Then it is possible to inject neutral gas from the nozzles, if the product is delicate. Finally, a mechanism pushes the sealing bar to the rubber support to seal the bag.

To obtain nice packages, the products and the bags have to be of proportional sizes. The bag's opening should never exceed 50 cm(2") past the seal bars. The product should be centered in height in relation to the seal bar by adjusting the spacers provided.

To obtain a good seal, make sure that no residue of fat is left between the bag's inner sides where sealing is done.

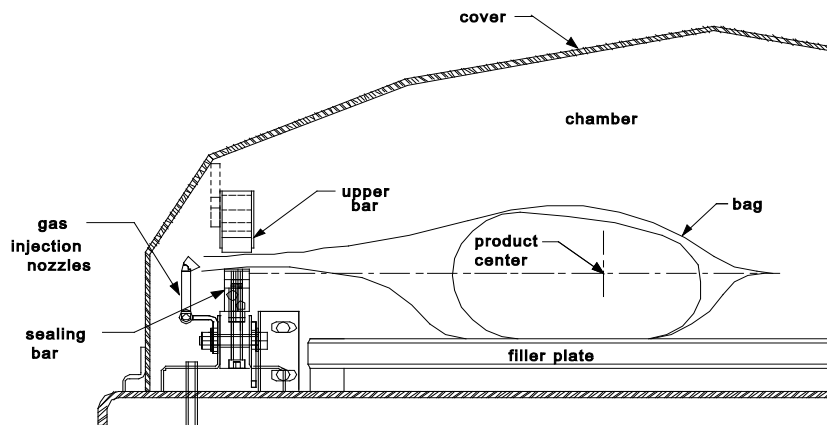

FIGURE 1

3.2 Special packaging:

3.2.1 Gas flushing (option):

There is an atmospheric pressure of 1 kg/ sq. cm (14 lbs/sq. inch) upon products when fully evacuated. Products which can be damaged by high pressure must be packaged with a partial vacuum, or the pressure must be counterbalance by inflating the bag with gas (nitrogen or carbon dioxide) before sealing after evacuation.

For gas flushing, the bags are placed on the sealing bars, the open end placed over the gas nozzles mounted alongside the sealing bar. After evacuation, the vacuum valve closes and the gas valve opens. Gas time (sec.) can be set in the program menu.

The necessary gas tank and pressure valve mounted on tank is not supplied, The pressure of the gas regulator should be set at approximately 1/3 kg/sq. cm (5 lbs/sq.inch.). Each machine has an adaptor for gas connection when gas flush option is ordered.

3.2.2 Top and bottom sealing (optional):

When sealing aluminium laminate bags (especially bags for e.g. coffee) it is imperative to have an upper and a lower sealing bar.

3.2.2 Electrical bag cut (optional):

This option is used to obtain a package that the excess bagtail is cut off close to the seal (cannot be used with top and bottom sealing).

3.3 Vacuum packaging operation:

3.3 Vacuum packaging operation:

Note: Refer to the menus structure on page 14 and the keyboard detail on page 15.

3.3.1 Basics:

Use key "POWER" to power ON / OFF the vacuum packaging machine. When the unit is energized, the identification of the last executed program is displayed on LCD screen.

Use the "ESC" key to change over from the programs menu to the functions menu and from the functions menu to the programs menu.

In functions menu, use key "SELECT" to select a function and key "ENTER" to accede and executed the selection.

In programs menu, use key "SELECT" to select a program and key "ENTER" to accede and modify the selection.

In programs submenu, use key "ENTER" to pass over the parameters and point to the following one; the parameters are blinking to point out the acquisition mode. A return to programs menu is performed automatically following the last parameter acquisition.

In program submenu, use key "ESC" to get back to the programs menu. Strike any key to clear the error messages which may be displayed on LCD screen.

3.3.2 Functions:

3.3.2.1 Create a program:

When executing the "create a program" function, the program submenu is acceded, starting with the identification. The initial identification "Pxx NO NAME" is given to the program and all parameters are established to zero; the program number is allocated automatically.

3.3.2.2 Delete a program:

When executing the "delete a program" function, the programs menu is acceded and the number of the first program in memory is blinking to point out the deletion mode. Use key "SELECT" to select a program and key "ENTER" to accede and confirm deletion of the selection. Use key "ESC" to unconfirm a deletion and to leave the function. When leaving the function, the number of the actual program on LCD screen cease to blink.

3.3.2.3 Select operating mode:

When executing the "select operating mode" function, which is available only for the automatic units, the actual selection is blinking to point out the acquisition mode. Use key "SELECT" to get through the operating modes, which are automatic, semi-automatic and manual; the validation of the selected operating mode is performed automatically. Use key "ESC" or "ENTER" to leave the function and get back to the program menu.

3.3.3 Programs menu:

3.3.3.1 Program identification:

For a selected program, set the identification, using the numeric keyboard characters chart; press numeric key until the desired character is selected (4 times for the numeric value). Use key "ENTER" to validate the character and to validate the characters string at the end (the new characters string is blinking). In a middle of an acquisition, use key "ESC" to come backward and erase one or several characters.

Example: EXAMPLE 1 → (9 characters)

keys 2, 2, ENTER	→ E
keys 8, 8, 8, ENTER	→ X
keys 1, ENTER	→ A
keys 5, ENTER	→ M
keys 6, ENTER	→ P
keys 4, 4, 4, ENTER	→ L
keys 2, 2, ENTER	→ E
keys 9, 9, 9, ENTER	→ space
keys 1, 1, 1, 1, ENTER	→ 1

key ENTER to validate the characters string

3.3.3.2 Vacuum level setting:

For a selected program set the vacuum level, starting with the values; the decimal point is automatically inserted following the second digit entry and the validation is automatically performed following the third digit entry (the new vacuum level is blinking). The vacuum level is rounded off to the nearest half value. In the middle of an acquisition, use key "ENTER" to validate the vacuum level and key "ESC" to come backward and start over with a new acquisition (the old vacuum level is blinking). Set vacuum level to zero to bypass the pressure transducer and proceed only using the vacuum plus time.

Examples: 90.0% → keys 9, 0, 0 or 9, 0, ENTER or
keys 9, 0, 1 or 9, 0, 2 or 9, 0, 3 or 9, 0, 4
97.5% → keys 9, 7, 5 or
keys 9, 7, 6 or 9, 0, 7 or 9, 0, 8 or 9, 0, 9
0.0% → keys 0, 0, 0 or 0, ENTER

3.3.3.3 Vacuum plus time setting:

For a selected program set the vacuum plus time, in seconds; the validation is automatically performed following the second digit entry (the new vacuum plus time is blinking). In a middle of an acquisition, use key "ENTER" to validate the vacuum plus time and key "ESC" to come backward and start over with a new acquisition (the old vacuum plus time is blinking).

Examples: 1s → keys 0, 1 or 1, ENTER
15s → keys 1, 5

3.3.3.4 Gas flush level setting:

For a selected program set the gas flush level following the same procedure as for the vacuum level; the maximum gas flush level setting is 10% below the vacuum setting.

3.3.3.5 Sealing time setting:

For a selected program set the sealing time, starting with the seconds; the decimal point is automatically inserted following the first digit entry and the validation is automatically performed following the third digit entry (the new sealing time is blinking). The sealing time is truncated to the nearest half hundredth. In a middle of an acquisition, use key "ENTER" to validate the sealing time and key "ESC" to come backward and start over with a new acquisition (the old sealing time is blinking).

Examples: 4.50s → keys 4, 5, 0 or 4, 5, ENTER or
keys 4, 5, 1 or 4, 5, 2 or 4, 5, 3 or 4, 5, 4
2.35s → keys 2, 3, 5 or
keys 2, 3, 6 or 2, 3, 7 or 2, 3, 8 or 2, 3, 9
0.00s → keys 0, 0, 0 or 0, ENTER

3.3.4 Vacuum cycle execution:

For the manual units and the automatic units set on manual, close the cover to initiate a vacuum cycle. For the automatic units set on semi-automatic or on automatic, use push button "STOP / START" to initiate or interrupt a vacuum cycle. A selected program can be initiated only in the programs menu, when no modifications are in progress, and the access to the other programs and functions is denied. During cycle execution the operation status is sequentially displayed on LCD screen, except for the parameters established to zero, which are not displayed:

- chamber vacuum level during vacuum sequence,
- vacuum plus time status during vacuum plus sequence,
- chamber vacuum level during gas flush sequence,
- sealing time status during sealing sequence,
- chamber vacuum level during atmosphere sequence.

During cycle execution, use key "1" to abort the vacuum sequence and execute the following sequence, which is gas flush or sealing, and key "ENTER" to accede and modify the program; the parameters become valid only for the following vacuum cycles.

3.3.5 System monitor:

To accede the diagnostics menu, power up the vacuum packaging machine while keeping pushed in the "ESC"key. Use key "SELECT" to select the system monitor function and key "ENTER" to accede and visualize the monitored parameters. Use key "SELECT" to change over from the software revision, the amount of working hours done and the amount of complete cycles performed since first initialization.

-MENUS STRUCTURE-

- **Functions menu:**
 - "F1 CREATE A PRGM"
 - "F2 DELETE A PRGM"
 - "F3 SELECT OPMODE" (automatic units only)
- **Programs menu:**
 - "Pxx NAME"
 - Program submenu:
 - "VACUUM: xx.x%" (10.0% - 99.5%)
 - "VACUUM PLUS: xxs"(0s - 99s)
 - "GAS FLUSH: xx.x%" (0.0% - 10% below the vacuum level) (units with gas option)
 - "SEAL TIME: x.xxs" (0.00s - maximum unit allocated setting)
 - "Pxx NAME" (12 characters)
- **Diagnostics menu** (keys "ESC" & "POWER" for access):
 - "DIAGNOSTICS MENU" (access code required)
 - "D1 INPUTS TEST"
 - "D2 OUTPUTS TEST"
 - "D3 MODEL SELECT"
 - "D4 GAS OPTION"
 - "D5 SEALING TIME"
 - "D6 COOLING TIME"
 - "D7 OFFSET CALIB."
 - "D8 VACUUM SENSOR"
 - "D9 SIPROMAC PUB"
 - "D10 LOADING TIME" (automatic units only)
 - "D11 UNLOADNG TIME" (automatic units only)
 - "SYSTEM MONITOR" (no access code required)
 - "SOFTWARE: R x.xx"
 - "WORK HRS: xxxxx"
 - "CYCLES: xxxxxxxx"

-KEYBOARD DETAILS-

MC-40 CONTROLS

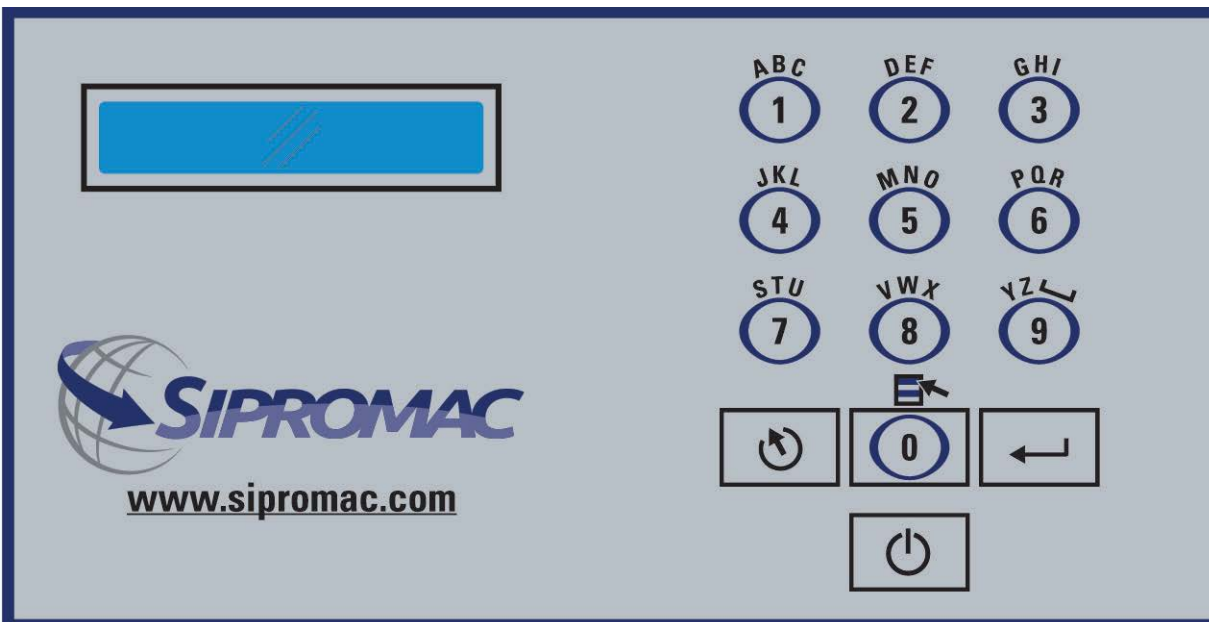



WARNING: All electrical work described in this brochure should be done by a QUALIFIED and AUTHORIZED technician.

3.4 Daily cleaning:

For hygienic cleanliness, it is imperative to clean chamber and spacers daily. Also clean the lid rubber to assure tight seat of the lid.

Cleaning instructions for gas injection nozzles: Periodically on a regular basis the gas injection nozzles must be removed with the connection tube and soaked in a food grade soap and water solution, then dried and re-installed.

4. TROUBLE SHOOTING:

4.1 Failure during packaging cycle:

4.1.1 "VACUUM ERROR" message is displayed on LCD:

No pressure variation is picked up by the PCB transducer during the vacuum sequence within a preset period of time.

- Check vacuum lines for potential leaks or kinks.

4.1.2 "GAS FLUSH ERROR" message is displayed on LCD:

No pressure variation is picked up by the PCB transducer during the gas flush sequence within a preset period of time.

- Check gas flush and vacuum lines for potential leaks or kinks.

4.1.3 "ATMOSPHERE ERROR" message is displayed on LCD:

No pressure variation is picked up by the PCB transducer during the atmosphere sequence within a preset period of time.

- Check vacuum lines for potential leaks or kinks.

4.1.4 "COVER DOWN ERROR" message is displayed on LCD(manual units):

The input signal of the down position switch has been lost during cycle execution.

- Check limit switch adjustment.

4.2 Insufficient vacuum:

4.2.1 Leakage in the bag:

Most frequently, insufficient vacuum in bags is due to leakage in bag and not due to any fault of the machine.

Pin-hole leak for which there is no obvious explanation is due to faulty bag material.

Pin-hole leak caused by sharp edge of the product (bone, etc.). Use bone-guard or thicker film.

Tear in bag by careless handling (sharp edge on filling table, damage made by retailer or customer).

Leakage in lateral or bottom seal, complain to supplier of bags or film.

4.2.2 No leakage in the bag:

Bag is too large, therefore the surplus of air remains visible (there is surplus of air in 0.4% of the bag volume in each bag). Use bags of suitable size.

Vacuum level is too low:

Pressure bar is jammed and closes opening of bag during evacuation.

4.2.3 Insufficient vacuum in chamber:

If troubles described under 4.2.1 and 4.2.2 do not apply, there is something wrong with the evacuation. To find the leakage quickly, check for leaks with a precision vacuumeter, going back step by step from the chamber to the pump.

At the chamber (measuring point at base of valve) at maximum time of evacuation. If more than 6 torr, proceed directly to the pump, if more than 3 torr: have pump service by pump supplier. If pressure at pump is good, reconnect hoses to pump and measure again.

Verify at vacuum hose connections and valve connections.

When proceeding this way, starting from pump, loss of pressure per step must not exceed 0.5 to 1 torr.

Caution: Verify connections of measuring equipment before verifying machine.

Most frequent points of leakage: lid gasket, damaged vacuum hose or loose hose clamps.

4.3 Faulty seal:

4.3.1 Insufficient seal:

Damaged teflon or silicone rubber.

Sealing pressure too low, bellows leaking or pressure bar jammed.

Leakers in seal: heating wire mechanically damaged (knicked) or silicone rubber uneven.

4.3.2 No seal:

Sealing wire burnt.

Faulty contact in sealing circuit.

Sealing transformer burnt through.

Contactors does not work.

4.3.3 Permanent sealing current:

Contactors is jammed check sealing transformer for damage through overload.

4.3.4 Seal does not stick:

Insufficient layer of polyethylene (inferior quality of bags).

Seal area extremely contaminated by fat or meat juice. Use filling aid.

Sealing temperature is too low (when using very thick films).

Caution: Do not increase sealing time more than really necessary; higher temperature will reduce working life of teflon and silicone rubber.

4.4 Fault in the valve:

Vacuum or air valve does not open.

Check whether there is voltage on the magnetic valves during their period of operation. If there is no voltage a wire is broken or the PC board is damaged.

Lid does not open at the end of the cycle; air enters, but there is still 20 - 40% vacuum in chamber. Vacuum valve does not close.

4.5 MC40 Control board failure

NOTE: Refer to menu structure on page 13.

This board software is allowing access to a "Diagnostics Menu". Only qualified service technicians are authorized to access this menu by entering a security password.

By accessing either the "D1 input test" feature or the "D2 output test" feature, a trained technician will be able to quickly know the origin of the problem: pump, sealing system, pneumatic problem, security switches problem, etc...

Keep in mind that in most cases trouble is due to a leakage, loose electrical connection or evident damage to the main components: vacuum pump, valves, electrical contactors, thermal overload, fuses holder or transformer.

For assistance do not hesitate to contact your local service technicians.

5. Regular maintenance:

Routine controls to be made at regular intervals:

Check teflon for wear.

Check silicone rubber for burnt spots and smooth even position.

Check pressure bar for jamming.

Check lid sealing for damage and hardened spots.

Check switch-point of micro switch, adjust if necessary.

Check evacuation hose for damage (contraction of diameter, or abrasions).

Check vacuum connections for tightness.

Check oil in pump (oil level in view glass; add if necessary. Regular change of oil - necessity indicated by change of color).

Check vacuum in chamber with precision vacuumeter.

Check function of cycle with various settings of timers.

MODEL 600A

COVER ADJUSTMENT PROCEDURE

Reference Drawing:# 005C0324
004C0122

PROBLEM: MACHINE TABLE AND COVER SEEMS TO BE STRAIGHT, LID GASKET IS GOOD BUT COVER DOES NOT SIT PROPERLY ON BOTH SIDES OF TABLE.

1. Floor should be flat (within 1/8" approx.).
 - 2.2 Loosen the two bolts of the guide arm axis (See drawing #004C0122; items #23).
 - 2.3 Now move the cover on each side and check how cover sits on the table. Distance between table and lid gasket should be less than 1/16" approx. If so, go to step 3.0 for guide arm adjustment. Otherwise go to step 2.4 for central arm adjustment.
 - 2.5 When closing cover (guide arm axis still loose), if cover is not sitting properly on either the front or rear of the table, you have to change the height of the flange bearings (See drawing # 004C0122; item #12) until cover is seating properly on each side. Normally shaft is centered in the table holes and the height is adjusted in a way that cover will slightly touch the back side of the table first.
3. Adjustment of guide arm: Both length of the guide arm and position on the guide arm axis have to be adjusted. Each of these should be adjusted separately. Fix the lower axis in a central position (centered in the holes) then adjust guide arm length until cover sit correctly on the right side. Move cover to the left side and check if cover sits correctly, if not move lower axis position and change length of the guide arm. Move the cover back to its original position to confirm, normally multiples tryout is required. Make sure there is no stress is transferred to the guide arm when machine is operating, stress induced arm will cause premature component fail.

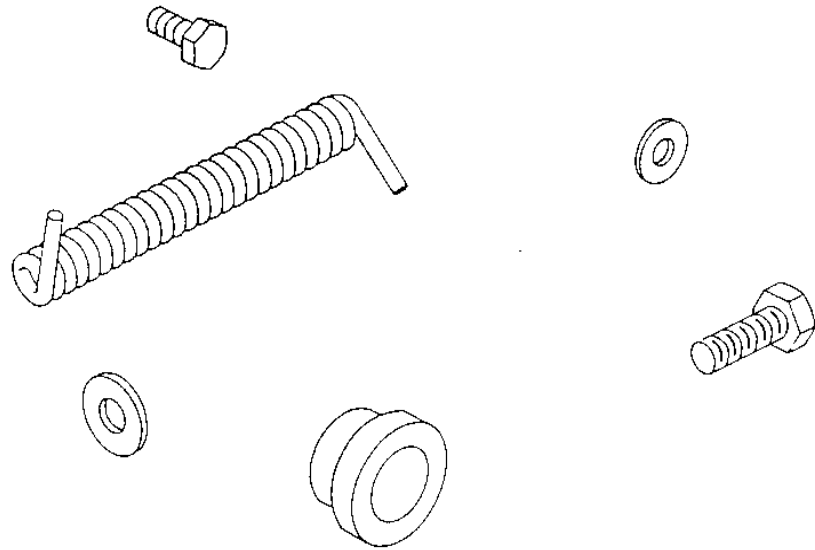

MECHANICAL DRAWING

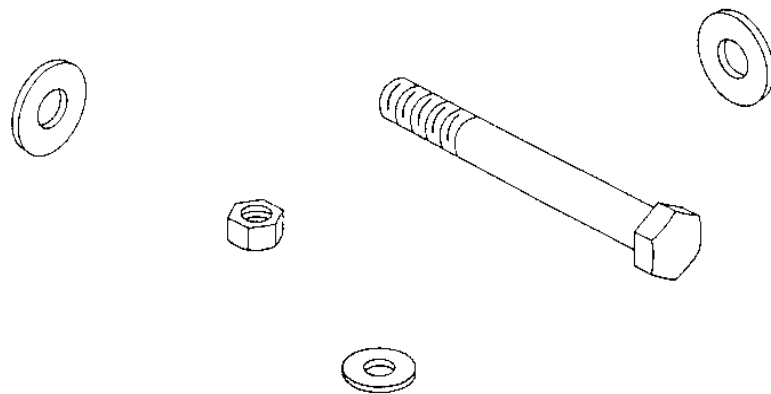

ITEM	PART #	DESCRIPTION	QT.	ITEM	PART #	DESCRIPTION	QT.
35	033-0021	MC-40 KEYBOARD "SUPPLY ONE"	1	1	004A1125	UPPER SEAL BAR ASSEMBLY (E.C.O.) & (TWIN)	2
36	036-0409	PRESSE-ETOUPE CD13	1	2	004A4106	VACUUM/ATMOSPHERE VALVE (OPT MUFFLER)	1
37	039-0191	THERMOSTAT HAMMOND	1			3	004A4107
38	039-0192	HEATER 100W HAMMOND	1	4	004A4108	VACUUM/ATMOSPHERE VALVE (OPT SOFT AIR + MUFFLER)	1
39	051-0210	BOLT 1/4"-20nc. X 1" S/S	6	5	004A4109	VACUUM/ATMOSPHERE VALVE (OPT MUFFLER)	1
40	051-0300	BOLT 5/16"-18 x 3/4" S/S	16	6	004A4110	VACUUM/ATMOSPHERE VALVE (OPT SOFT AIR)	1
41	051-0601	NUT 5/16"-18 NYLON LOCK S/S	16	7	004A4111	VACUUM/ATMOSPHERE VALVE (OPT SOFT AIR+MUFFLER)	1
42	051-0740	WASHER 1/4" FLAT S/S	6	8	004A4141	PUMP "BUSCH" 305 M³	1
43	051-0760	WASHER 5/16" FLAT S/S	32	9	004A4146	BASE MACHINE ASSEMBLY	1
44	057-0460	PLUG 3/4" BLACK	1	10	004B1468	PUMP "BUSCH" 100 M³ ASSEMBLY	1
45	104-0064	SILICONE TUBING 3/8" OD x 3/16" ID x 80mm	2	11	004B1469	PUMP "BUSCH" 165 M³ ASSEMBLY	1
46	130-4PHB	4" SWIVEL CASTER W/BRAKE	4	12	004B1471	PUMP "BUSCH" 255 M³	1
				13	004B4103	AIR REGULATOR VALVE ASSY	1
				14	004B4104	BELLOWS VALVE ASSY	1
				15	004B4105	BELLOWS VALVE ASSY (OPT AIR REG)	1
				16	004B4113	GAS VALVE ASSEMBLY (OPTION)	2
				17	005A0423	FRONT GAS 3 INJECTION BAR ASSEMBLY	2
				18	005A0424	FRONT GAS 4 INJECTION BAR ASSEMBLY	2
				19	005A0560	SEAL BAR ASS'Y W/SUPPORT	4
				20	005A0812	REAR GAS 3 INJECTION BAR ASSEMBLY	2
				21	005A0813	REAR GAS 4 INJECTION BAR ASSEMBLY	2
				22	005B0453	8" COVER ASSEMBLY	1
				23	005B0454	12" COVER ASSEMBLY	1
				24	005B0562	SEAL BAR ASS'Y W/SUPPORT (T&B)	4
				25	005B0583	MC-40 CONTROL BOARD	1
				26	005C0421	UPPER SEAL BAR ASS'Y W/SUPPORT	2
				27	005F0561	SEAL BAR ASS'Y W/SUPPORT (ECO)	4
				28	009C0136	8" TOP & BOTTOM COVER REWORKED	1
				29	009C0137	12" TOP & BOTTOM COVER REWORKED	1
				30	033-0014	MC-40 KEYBOARD "FOODPAK"	1
				31	033-0015	MC-40 KEYBOARD "SIPROMAC"	1
				32	033-0016	MC-40 KEYBOARD "HOLLYMATIC"	1
				33	033-0018	MC-40 KEYBOARD "BERKEL"	1
				34	033-0019	MC-40 KEYBOARD "BSA"	1

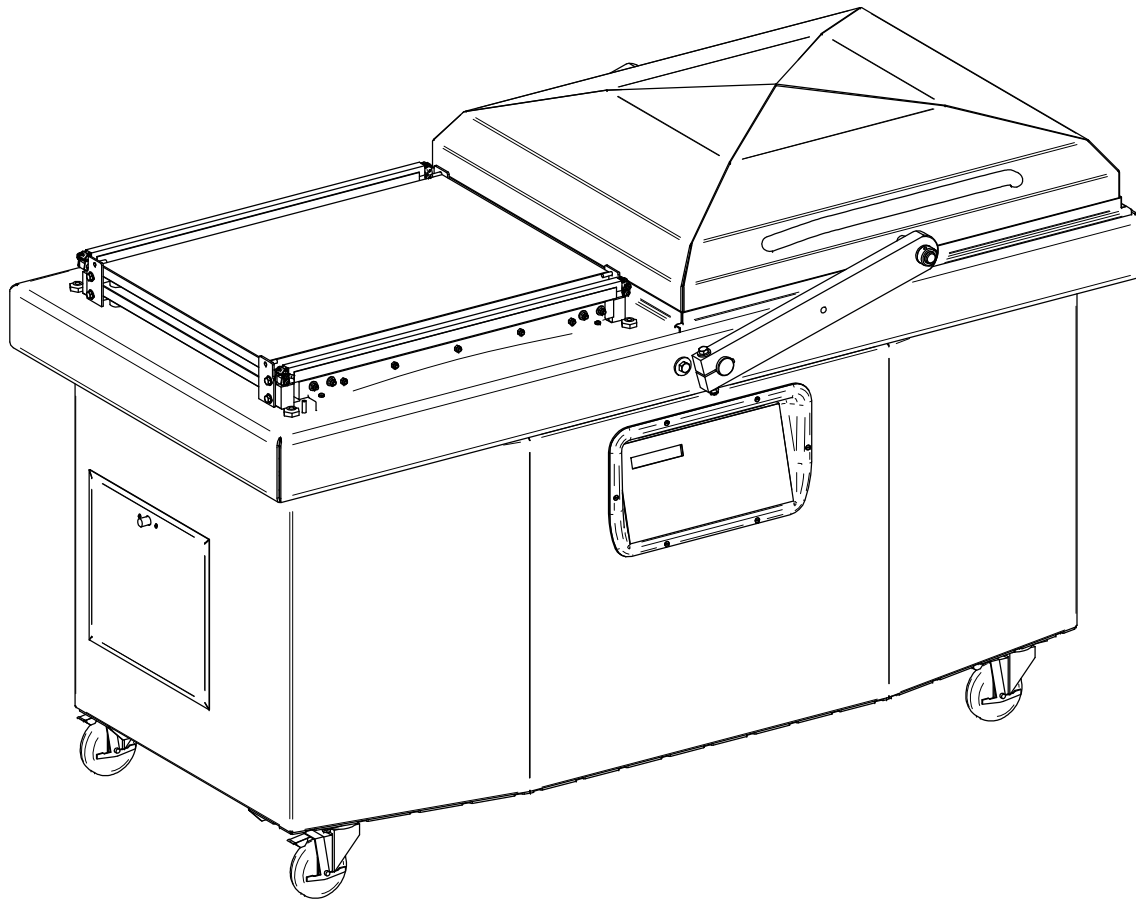

MACHINE		600A		DEPT. TOL	METRIC	INCH	SIPROMAC ST-GERMAIN DE GRANTHAM QUEBEC CANADA
PART		MACHINE ASSEMBLY		USINAGE	± 0.1	± 0.004"	
ITEM		CNC		TOLERIE	± 0.5	± 0.020"	
MAT.		APP. BY		SBU		DATE	13-12-11
LET.		MODIFICATION		DATE		INT.	1
							N.T.S.
							M-I
							005D0324

A	004B4103, 004B4104, 004B4105 WAS A. 005F0561 WAS E	14-05-27	SBU
LET.	MODIFICATION	DATE	INT.

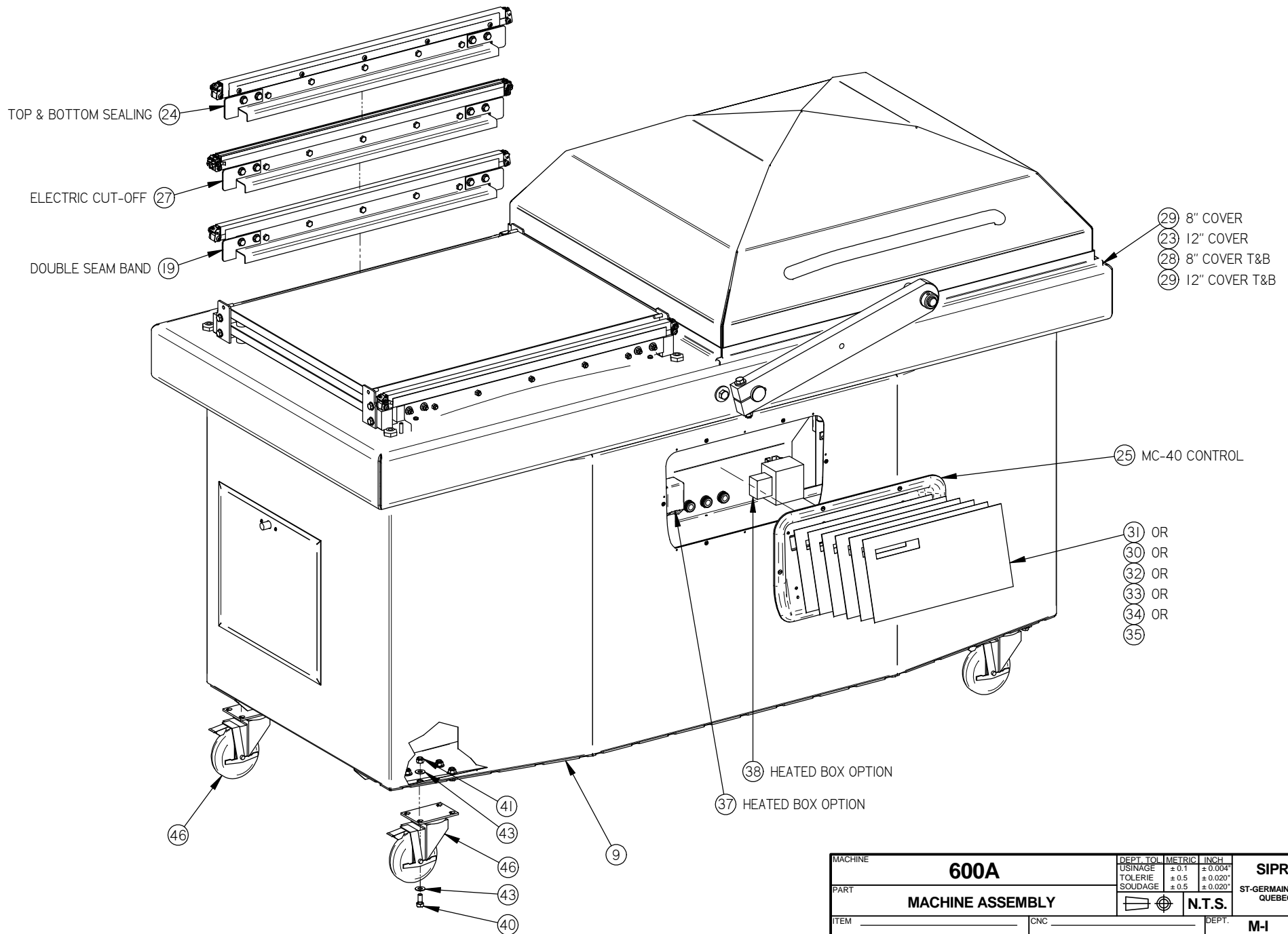

MACHINE	600A		DEPT. TOL.	METRIC	INCH	SIPROMAC ST-GERMAIN DE GRANTHAM QUEBEC CANADA
PART	MACHINE ASSEMBLY		USINAGE	± 0.1	± 0.004"	
ITEM	CNC		TOLERIE	± 0.5	± 0.020"	
MAT.	APP. BY	SBU	DATE	13-12-11	NO.	005D0324
						DEPT. M-I QTY. 1

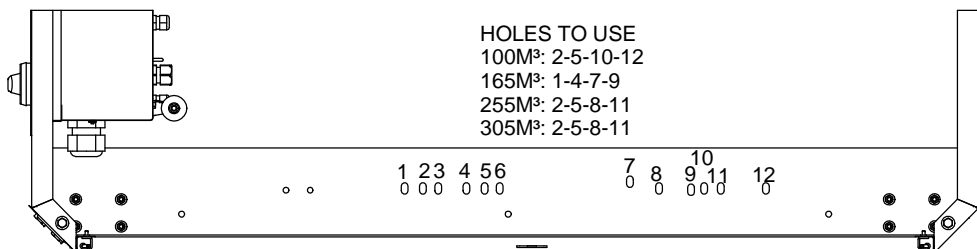
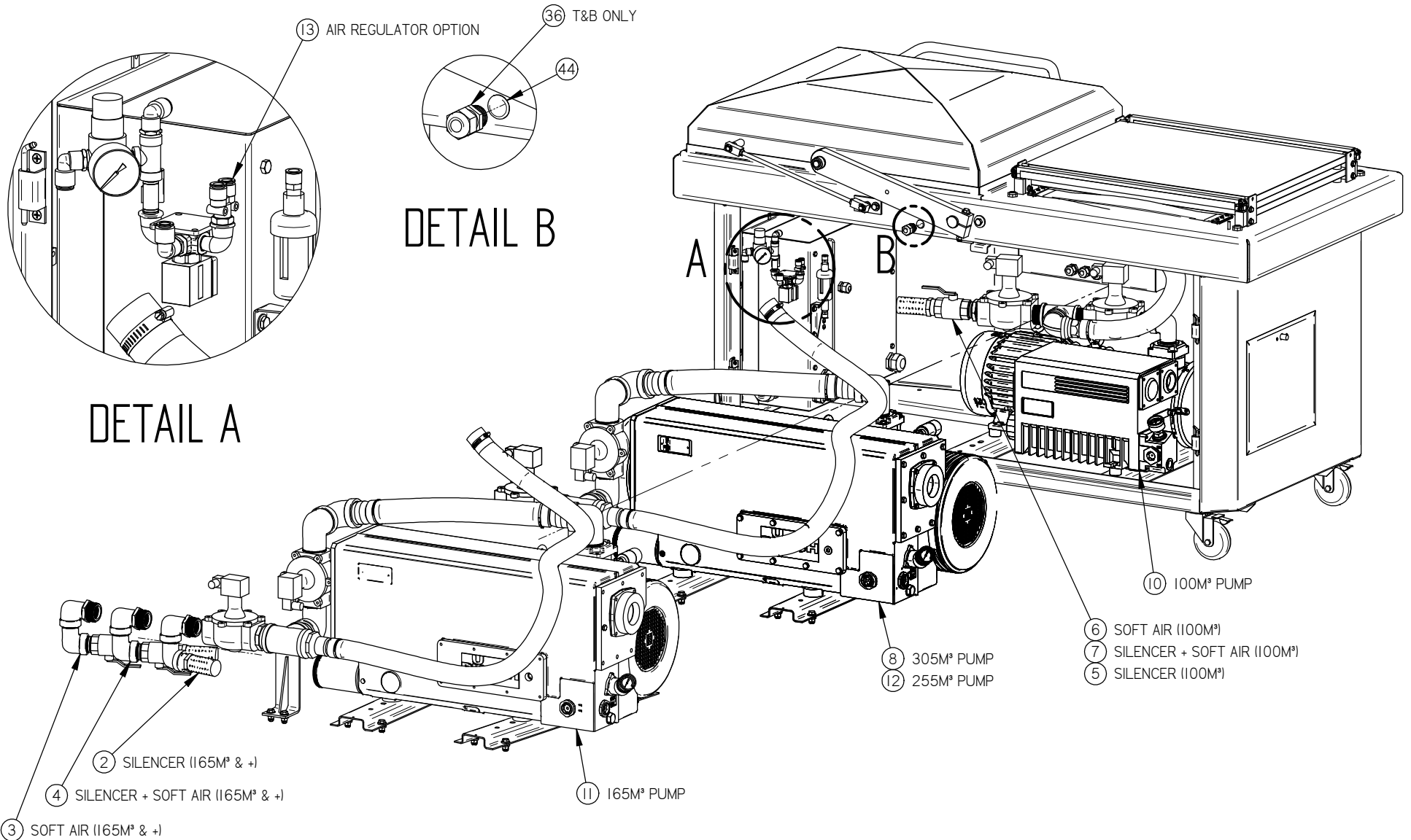

-PUMP + AIR REGULATOR INSTALLATION-

MACHINE		600A		DEPT. TOL.	METRIC	INCH	SIPROMAC	
PART		MACHINE ASSEMBLY		USINAGE	± 0.1	± 0.004"	ST-GERMAIN DE GRANTHAM QUEBEC CANADA	
ITEM		CNC		TOLERIE	± 0.5	± 0.020"	N.T.S.	
MAT.		APP. BY		SOUDEGE	± 0.5	± 0.020"	DEPT. M-I QTY. 1	
		DWG BY SBU		DATE 13-12-11		NO. 005D0324		
		APP. BY		DATE				

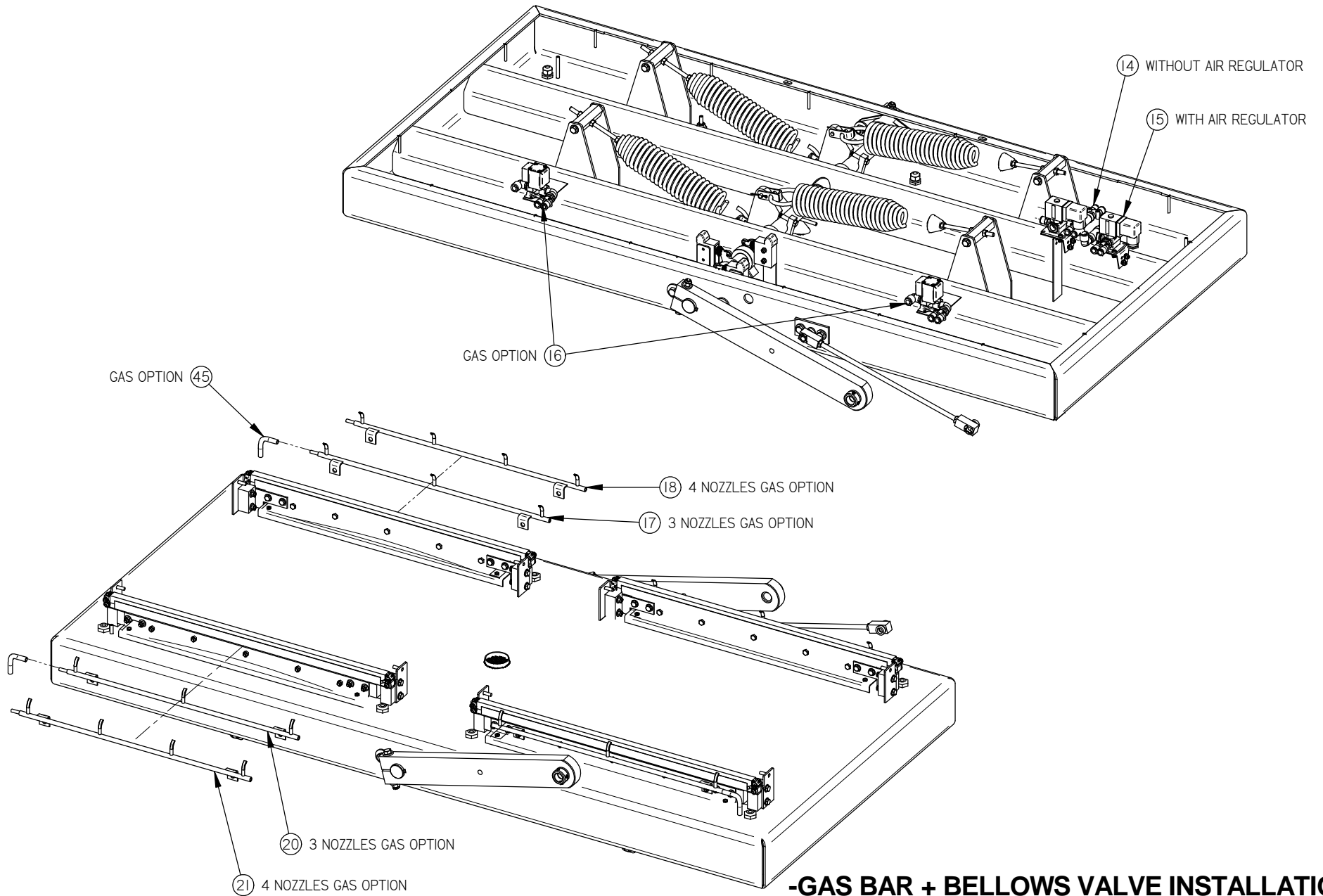

-GAS BAR + BELLOWS VALVE INSTALLATION-

MACHINE 600A		DEPT. TOL. METRIC	INCH	SIPROMAC ST-GERMAIN DE GRANTHAM QUEBEC CANADA
PART MACHINE ASSEMBLY		USINAGE ± 0.1 ± 0.004"	N.T.S.	
ITEM _____		TOLERIE ± 0.5 ± 0.020"		
MAT. _____		SOUDEGE ± 0.5 ± 0.020"		DEPT. M-I QTY. 1
APP. BY _____		DWG BY SBU DATE 13-12-11	NO. 005D0324	
		DATE _____		

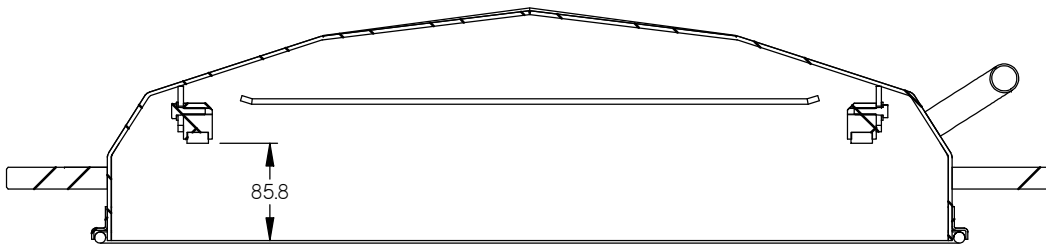
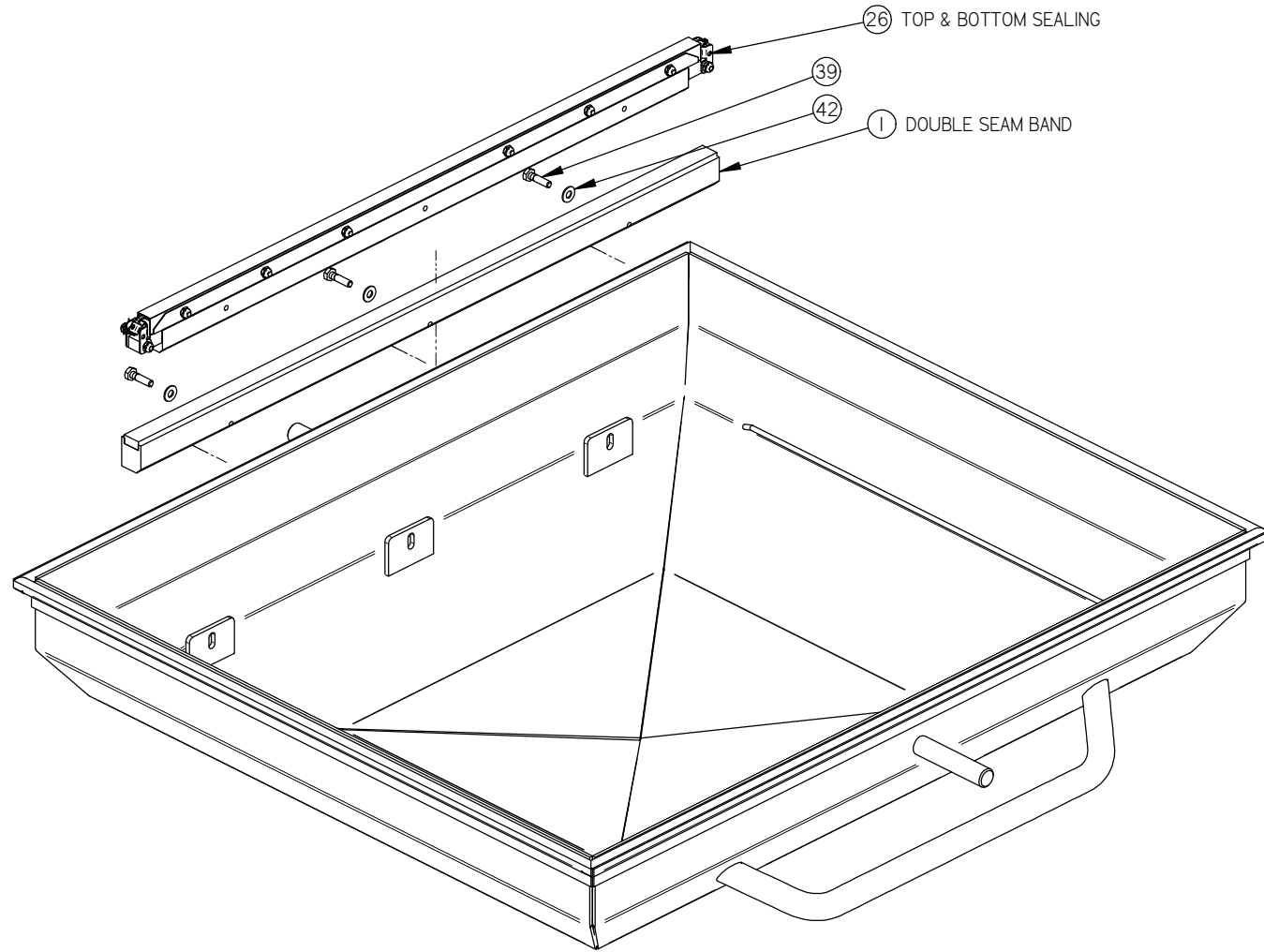

-UPPER SEAL BAR INSTALLATION-

MACHINE		600A		DEPT. TOL.	METRIC	INCH	SIPROMAC ST-GERMAIN DE GRANTHAM QUEBEC CANADA	
PART		MACHINE ASSEMBLY		USINAGE	± 0.1	± 0.004"		
ITEM		CNC		TOLERIE	± 0.5	± 0.020"		
MAT.		APP. BY		DATE	13-12-11	N.T.S.	DEPT. M-I	
				DATE			QTY. 1	
							005D0324	

005D0457

ITEM	PART #	DESCRIPTION	QT.	ITEM	PART #	DESCRIPTION	QT.
11	056-3010-1	HINGE CONCEALED SS304 - BASE	4	1	004A4090	ACCESS DOOR ASSEMBLY	1
12	056-3010-3	HINGE CONCEALED SS304 - PIN	4	2	004A4098	ELECTRIC BOX ASS'Y	1
13	102-0551	BULKHEAD 1/4"NPT X 3/8 TUBE QUICK	2	3	004A4138	VACUUM SENSOR FILTER	1
14	127-0040	STICKER "AIR" BLUE/WHITE 1" X 2"	1	4	004E0114	STRUCTURE PRE-ASSEMBLY	1
15	127-0041	STICKER "GAS" YELLOW/BLACK 1" X 2"	1	5	036-0265	GROMMET 1-1/2" ID X 2-3/8" OD RUBBER	1
				6	036-0409	PRESSE-ETOUPE CD13	3
				7	051-01385	SCREW 10-24 x 1/2"FLAT-UND. PHIL S/S	8
				8	051-0144	SCREW #10-24 N.C 1/2"PAN PHIL. S/S	8
				9	051-0180	BOLT. HEX. 1/4"-20 NC. x 1/2" S/S	2
				10	051-0740	WASHER 1/4" FLAT S/S	2

DETAIL B

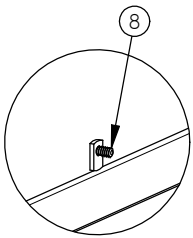
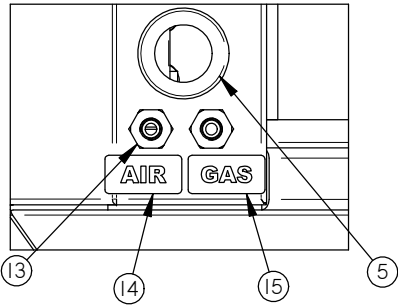

DETAIL A

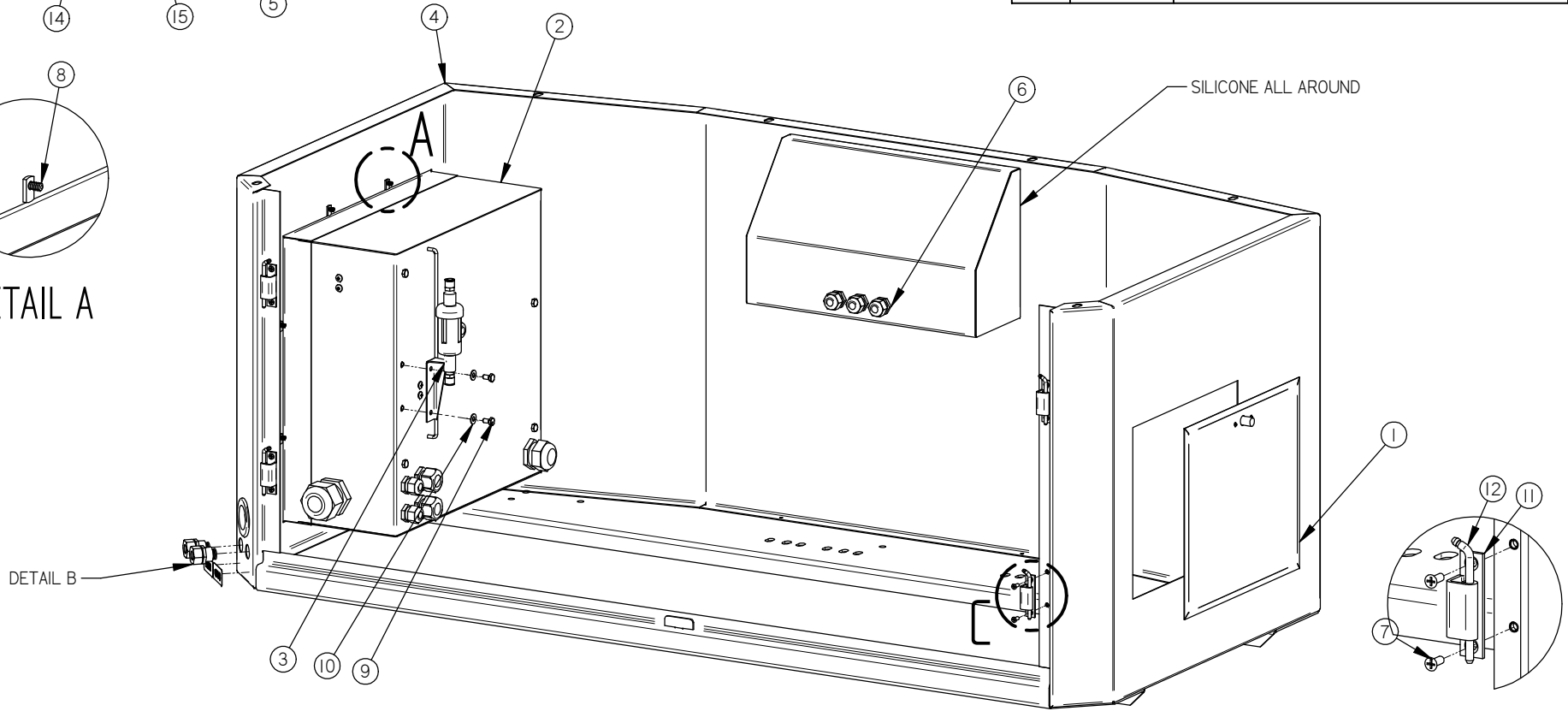

DETAIL C

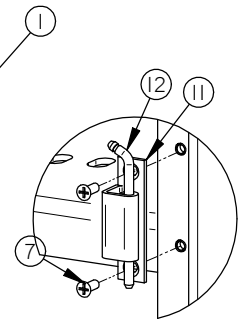

MACHINE		600A & 620A		DEPT. TOL.	METRIC	INCH	SIPROMAC ST-GERMAIN DE GRANTHAM QUEBEC CANADA
PART		STRUCTURE ASS'Y		USINAGE	± 0.1	± 0.004"	
				TOLERIE	± 0.5	± 0.020"	
				SOUDEAGE	± 0.5	± 0.020"	N.T.S.
ITEM	CNC	DEPT.	M-(M)-I	QTY.	1		
MAT.	DWG BY SBU	DATE 15-02-24	NO. 005D0457				
	APP. BY	DATE					

B	004E0114 WAS 004D0114	15-02-24	SBU
LET.	MODIFICATION	DATE	INT.

005C0583

ITEM	PART #	DESCRIPTION	QT.
1	001B6920	CONTROL PANEL MC-40	1
2	033-0038	MC-40 SENSOR VACUUM	1
3	051-0092	SCREW #4-40 x 1 1/4" FLAT SLT S/S	4
4	051-01081	SCREW 8-32 X 1/2" TRUSS SLOT SS	6
5	051-0540	NUT #4-40 HEX S/S	8
6	051-0713	WASHER #4 FLAT S/S	4
7	051-0715	WASHER #4 LOCK SS	4
8	058-0120	CPVC SPACER 0.120" x 1/4" x 5/8"	4
9	179-0004	NITRILE 1/2" X 1/8" AUTOCOLLANT X 1210mm long	1

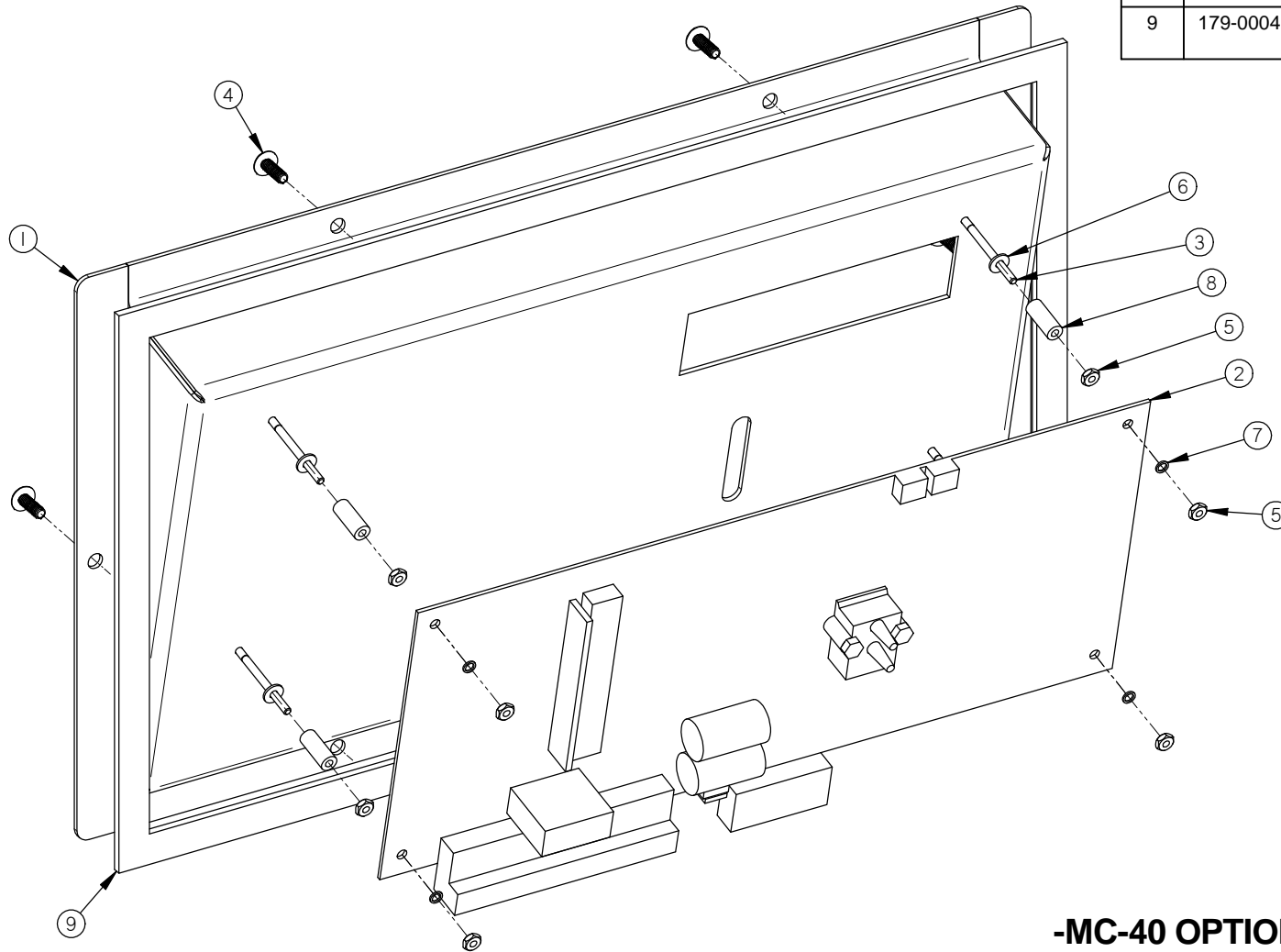

-MC-40 OPTION-

MACHINE		VACUUM		DEPT. TOL.	METRIC	INCH	SIPROMAC ST-GERMAIN DE GRANTHAM QUEBEC CANADA
PART		MC-40 CONTROL BOARD		USINAGE	± 0.1	± 0.004"	
ITEM		CNC		TOLERIE	± 0.5	± 0.020"	
MAT.		3D DWG BY SBU		DATE	15-02-23		NO. 005C0583
LET.		2D DWG BY SBU		DATE	15-02-23		
				DEPT.	M		QTY. 1

A	SS INSERT	15-02-23	SBU
LET.	MODIFICATION	DATE	INT.

005B0454

ITEM	PART #	DESCRIPTION	QT.
1	004B0237	12" COVER PRE-ASS'Y	1
2	179-0020	NEOPRENE SPONGE 1/2" x 14.5'	1

USE PERMATEx RUBBER ADHESIVE 169-0010 TO GLUE (2) UTILISER PERMATEx RUBBER ADHESIVE 169-0010 POUR COLLER

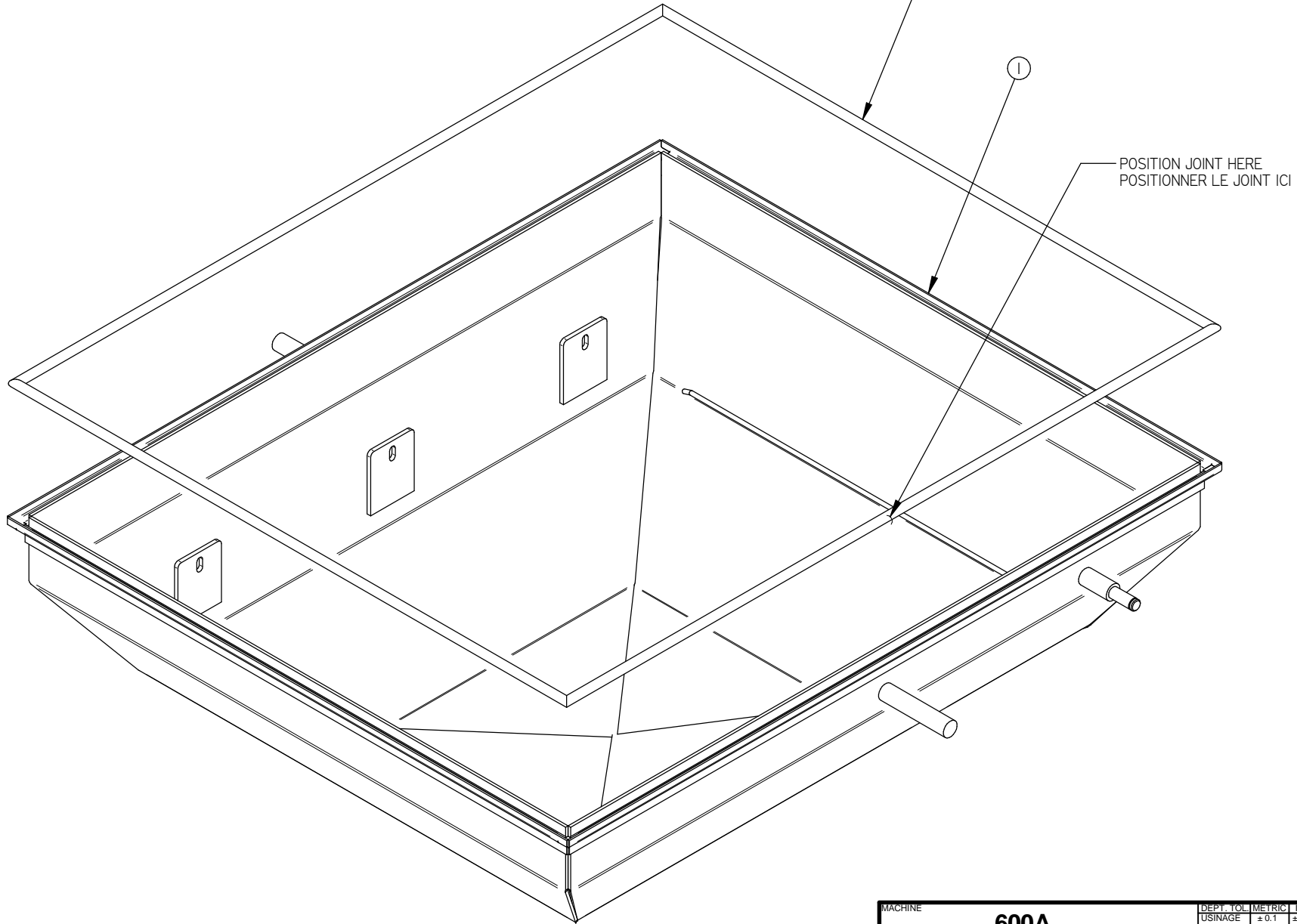

C	004B0237 WAS 004A0237	14-02-04	SBU
LET.	MODIFICATION	DATE	INT.

MACHINE	600A	DEPT. TOL. METRIC	INCH	SIPROMAC ST-GERMAIN DE GRANTHAM QUEBEC CANADA
PART	12" COVER ASSEMBLY	USINAGE ± 0.1 ± 0.004"	TOLERIE ± 0.5 ± 0.020"	
		TOLERIE ± 0.5 ± 0.020"	SOUDEAGE ± 0.5 ± 0.020"	
ITEM	CNC	N.T.S.		DEPT. M-(M)-I QTY. 1
MAT.	DWG BY SBU	DATE 14-02-04	NO. 005B0454	
	APP. BY	DATE		

005B0453

ITEM	PART #	DESCRIPTION	QT.
1	004B0236	8" COVER PRE-ASS'Y	1
2	179-0020	NEOPRENE SPONGE 1/2" x 14.5'	1

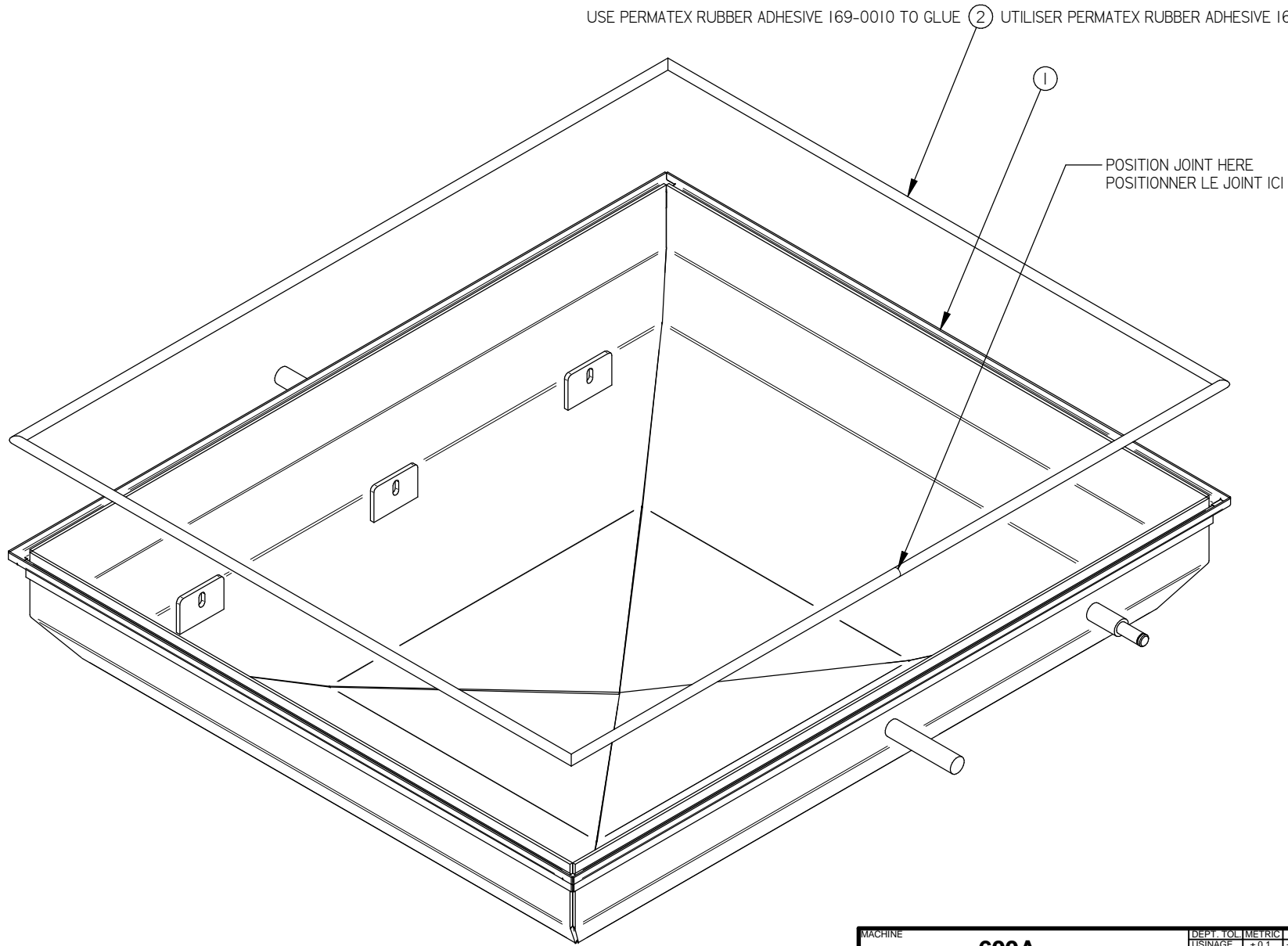

C	004B0236 WAS 004A0236	14-02-04	SBU
LET.	MODIFICATION	DATE	INT.

MACHINE	600A	DEPT. TOL. METRIC	INCH	SIPROMAC ST-GERMAIN DE GRANTHAM QUEBEC CANADA
PART	8" COVER ASSEMBLY	USINAGE ± 0.1 ± 0.004"	TOLERIE ± 0.5 ± 0.020"	
ITEM		SOUDEAGE ± 0.5 ± 0.020"	N.T.S.	
MAT.		CNC	DEPT.	M-(M)-I
		DWG BY SBU	DATE 14-02-04	NO. 005B0453
		APP. BY	DATE	QTY. 1

004A4146

ITEM	PART #	DESCRIPTION	QT.
1	004A4095	LEFT REAR ACCESS DOOR PRE-ASSY	1
2	004A4097	RIGHT REAR ACCESS DOOR ASSY	1
3	004A4145	TABLE W/ARM ASSY	1
4	005A0322	FILLER PLATE ASSEMBLY	4
5	005D0457	STRUCTURE ASS'Y	1
6	051-0360	BOLT 3/8"-16nc. X 1" S/S	6
7	051-0622	NUT 3/8"-16nc. NYLON LOCK S/S	6
8	051-0783	WASHER 3/8" FLAT THICK S/S	12

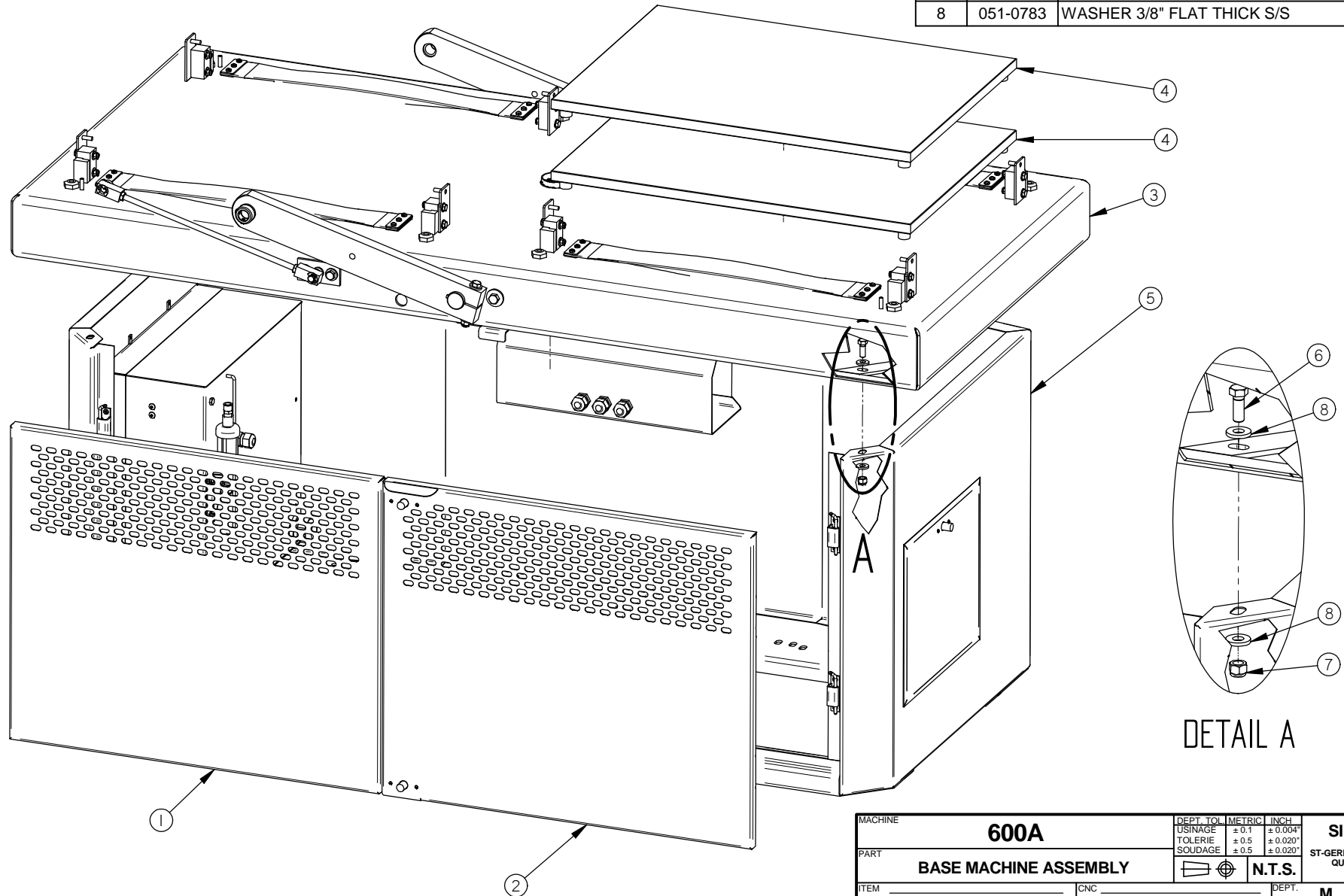

DETAIL A

A	005D0457 WAS 005C0457	15-04-24	SBU
LET.	MODIFICATION	DATE	INT.

MACHINE		600A		DEPT. TOL	METRIC	INCH	SIPROMAC ST-GERMAIN DE GRANTHAM QUEBEC CANADA
PART		BASE MACHINE ASSEMBLY		USINAGE	± 0.1	± 0.004"	
				TOLERIE	± 0.5	± 0.020"	
				SOUDEAGE	± 0.5	± 0.020"	
ITEM		CNC		N.T.S.		DEPT.	M
MAT.		DWG BY	SBU	DATE	13-11-26	NO.	1
		APP. BY		DATE		004A4146	

004A4138

ITEM	PART #	DESCRIPTION	QT.
1	004A4139	VACUUM SENSOR FILTER SUPPORT	1
2	114-2020	FILTER / DRYER 1/4"mnpt. X 1/4"t.p. COMP.	1
3	102-0410	MALE CONN.1/4"MNPTx3/8"T.QUICK	2

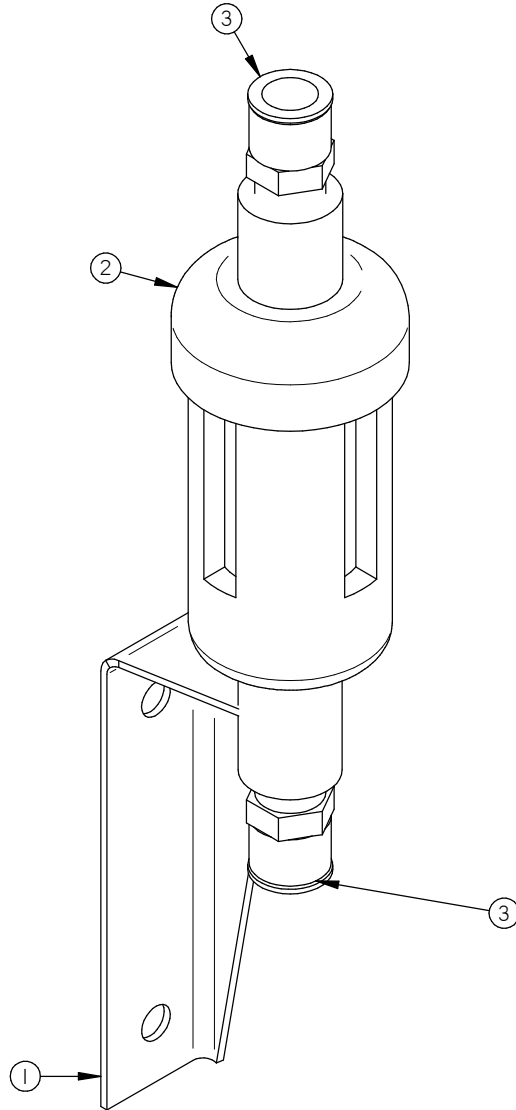

MACHINE		VACUUM		DEPT. TOL.	METRIC	INCH	SIPROMAC ST-GERMAIN DE GRANTHAM QUEBEC CANADA
PART		VACUUM SENSOR FILTER		USINAGE ± 0.1	± 0.004"	N.T.S.	
ITEM		CNC		TOLERIE ± 0.5	± 0.020"		
MAT.		DWG BY SBU		DATE 13-11-19	NO. 004A4138		DEPT. M
LET.		MODIFICATION		DATE	INT.	QTY. 1	

004A4090

ITEM	PART #	DESCRIPTION	QT.
1	004A4089	ACCESS PANEL PRE-ASSY	1
2	056-2600	SPRING PAWL LATCHE SS KNOB	1
3	051-0071	SCREW 4-40 x 1/4" RND SLOT S/S	2
4	051-0541	NUT # 4-40 NYLON LOCK SS	2

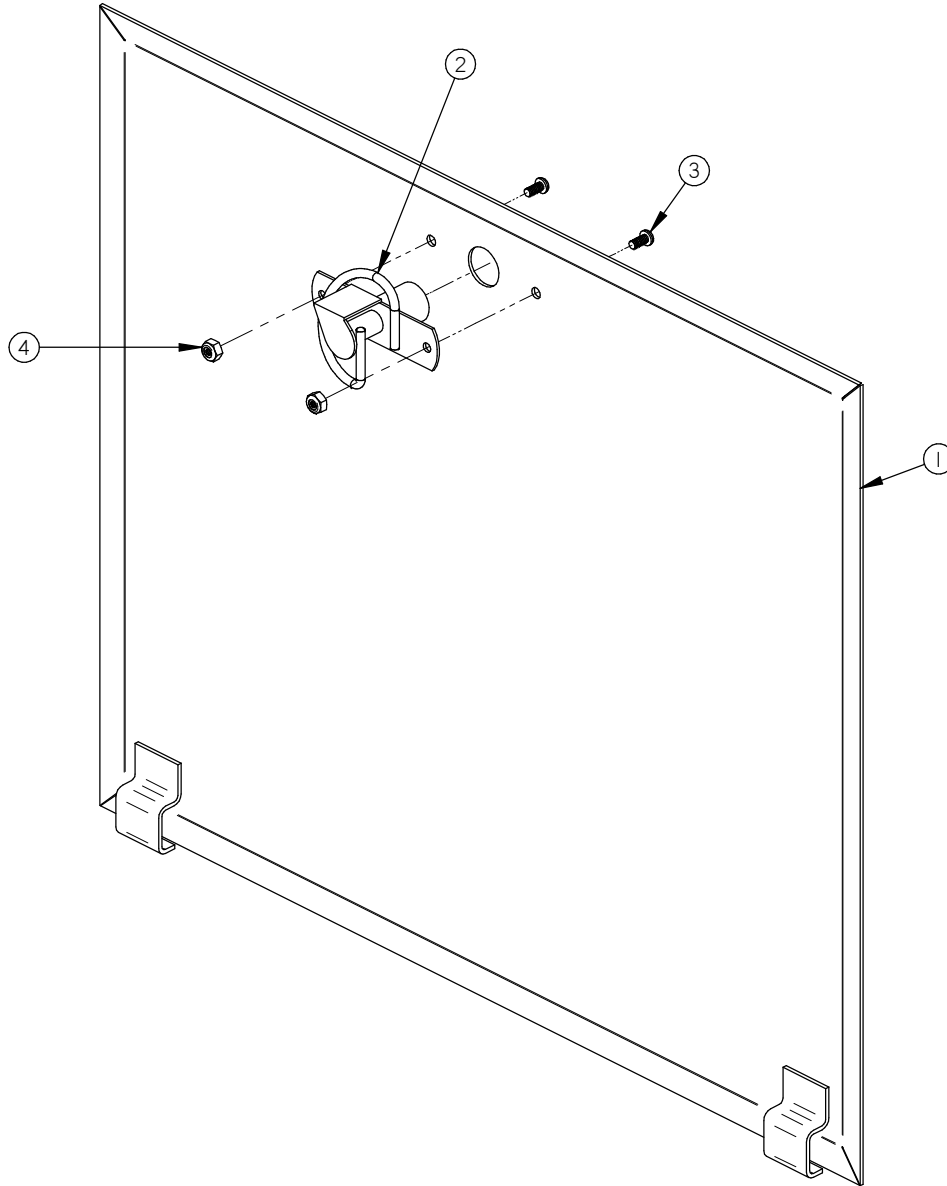

LET.	MODIFICATION	DATE	INT.
------	--------------	------	------

MACHINE		VACUUM		DEPT. TOL.	METRIC	INCH	SIPROMAC ST-GERMAIN DE GRANTHAM QUEBEC CANADA
PART		ACCESS DOOR ASSEMBLY		USINAGE	± 0.1	± 0.004"	
				TOLERIE	± 0.5	± 0.020"	
				SOUDEAGE	± 0.5	± 0.020"	N.T.S.
ITEM		CNC		DEPT.	M	QTY.	1
MAT.		DWG BY	SBU	DATE	13-09-11	NO.	004A4090
		APP. BY		DATE			

004A4145

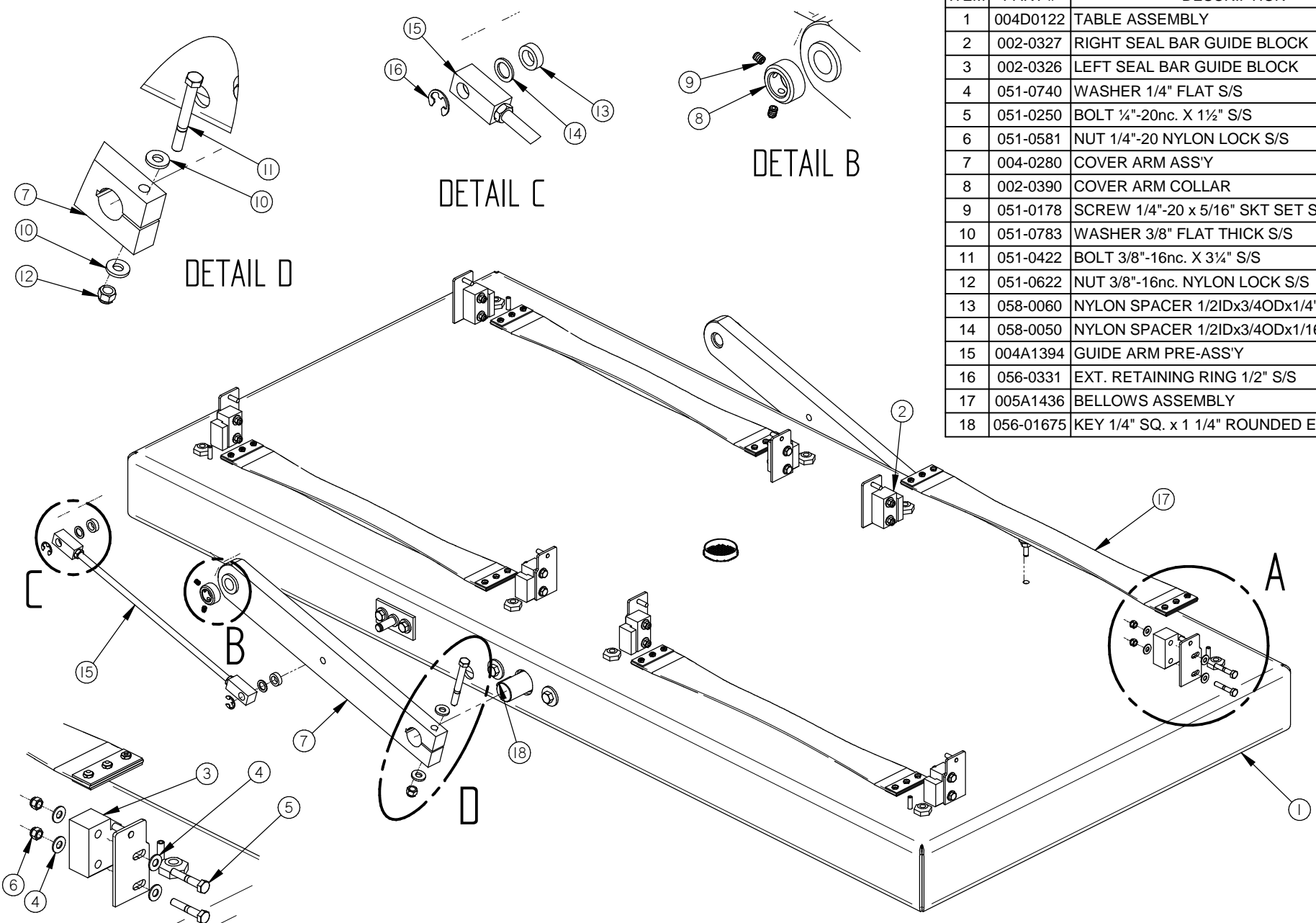

ITEM	PART #	DESCRIPTION	QT.
1	004D0122	TABLE ASSEMBLY	1
2	002-0327	RIGHT SEAL BAR GUIDE BLOCK	4
3	002-0326	LEFT SEAL BAR GUIDE BLOCK	4
4	051-0740	WASHER 1/4" FLAT S/S	32
5	051-0250	BOLT 1/4"-20nc. X 1 1/2" S/S	16
6	051-0581	NUT 1/4"-20 NYLON LOCK S/S	16
7	004-0280	COVER ARM ASS'Y	2
8	002-0390	COVER ARM COLLAR	2
9	051-0178	SCREW 1/4"-20 x 5/16" SKT SET S/S	4
10	051-0783	WASHER 3/8" FLAT THICK S/S	4
11	051-0422	BOLT 3/8"-16nc. X 3/4" S/S	2
12	051-0622	NUT 3/8"-16nc. NYLON LOCK S/S	2
13	058-0060	NYLON SPACER 1/2IDx3/4ODx1/4"	2
14	058-0050	NYLON SPACER 1/2IDx3/4ODx1/16"	2
15	004A1394	GUIDE ARM PRE-ASS'Y	1
16	056-0331	EXT. RETAINING RING 1/2" S/S	2
17	005A1436	BELLOWS ASSEMBLY	4
18	056-01675	KEY 1/4" SQ. x 1 1/4" ROUNDED END S/S	2

DETAIL A

DETAIL C

DETAIL B

DETAIL D

MACHINE	600A		DEPT. TOL.	METRIC	INCH	SIPROMAC ST-GERMAIN DE GRANTHAM QUEBEC CANADA
PART	TABLE W/ARM ASSY		USINAGE	± 0.1	± 0.004"	
			TOLERIE	± 0.5	± 0.020"	
			SOUDEAGE	± 0.5	± 0.020"	N.T.S.
ITEM	CNC	DEPT.	M	QTY.	1	
MAT.	DWG BY	SBU	DATE	13-11-28	NO.	004A4145
	APP. BY		DATE			

A	005A1436 WAS 005-0320 (FIT BAR 620A)	14-01-08	SBU
LET.	MODIFICATION	DATE	INT.

004A1394

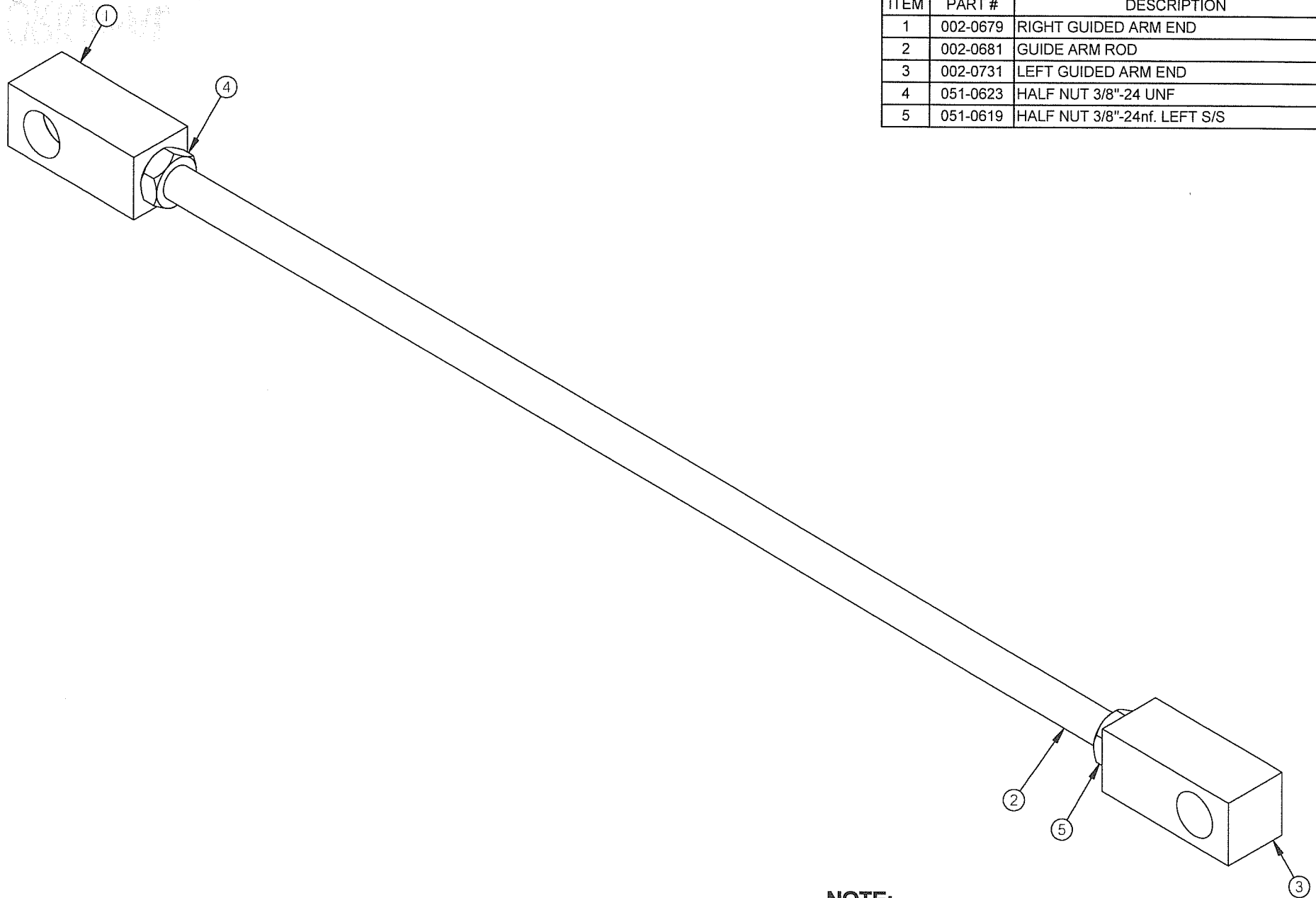

ITEM	PART #	DESCRIPTION	QT.
1	002-0679	RIGHT GUIDED ARM END	1
2	002-0681	GUIDE ARM ROD	1
3	002-0731	LEFT GUIDED ARM END	1
4	051-0623	HALF NUT 3/8"-24 UNF	1
5	051-0619	HALF NUT 3/8"-24nf. LEFT S/S	1

NOTE:

-PASSER AU JET DE SABLE APRÈS AVOIR ASSEMBÉ LES 5 ITEMS.

MACHINE		DEPT. TOL. METRIC		INCH		SIPROMAC	
600 & 620		USINAGE	± 0.1	± 0.004"	ST-GERMAIN DE GRANTHAM		
PART		TOLERIE	± 0.5	± 0.020"	QUEBEC CANADA		
GUIDE ARM PRE-ASS'Y		SOUDEGE	± 0.5	± 0.020"	N.T.S.		
ITEM	CNC	DEPT.	U-J-(M)		QTY.		1
MAT.	DWG BY J.C.	DATE	03-12-09		NO		004A1394
	APP. BY	DATE	08-05-08				

A	AJOUTER JET DE SABLE	08-02-15	J.G.
LET.	MODIFICATION	DATE	INT.

005A1436

ITEM	PART #	DESCRIPTION	QT.
1	008A1996	BELLOWS	1
2	001-0899	BELLOWS CLAMP	4
3	051-0105	SCREW #8-32 x 7/16" TRUSS PHIL S/S	6
4	051-0550	NUT #8-32 SS	6
5	003-0022	BELLOWS CONNECTOR	1
6	051-0620	NUT 3/8"-16 NC S/S	1
7	051-0780	WASHER 3/8" FLAT S/S	1

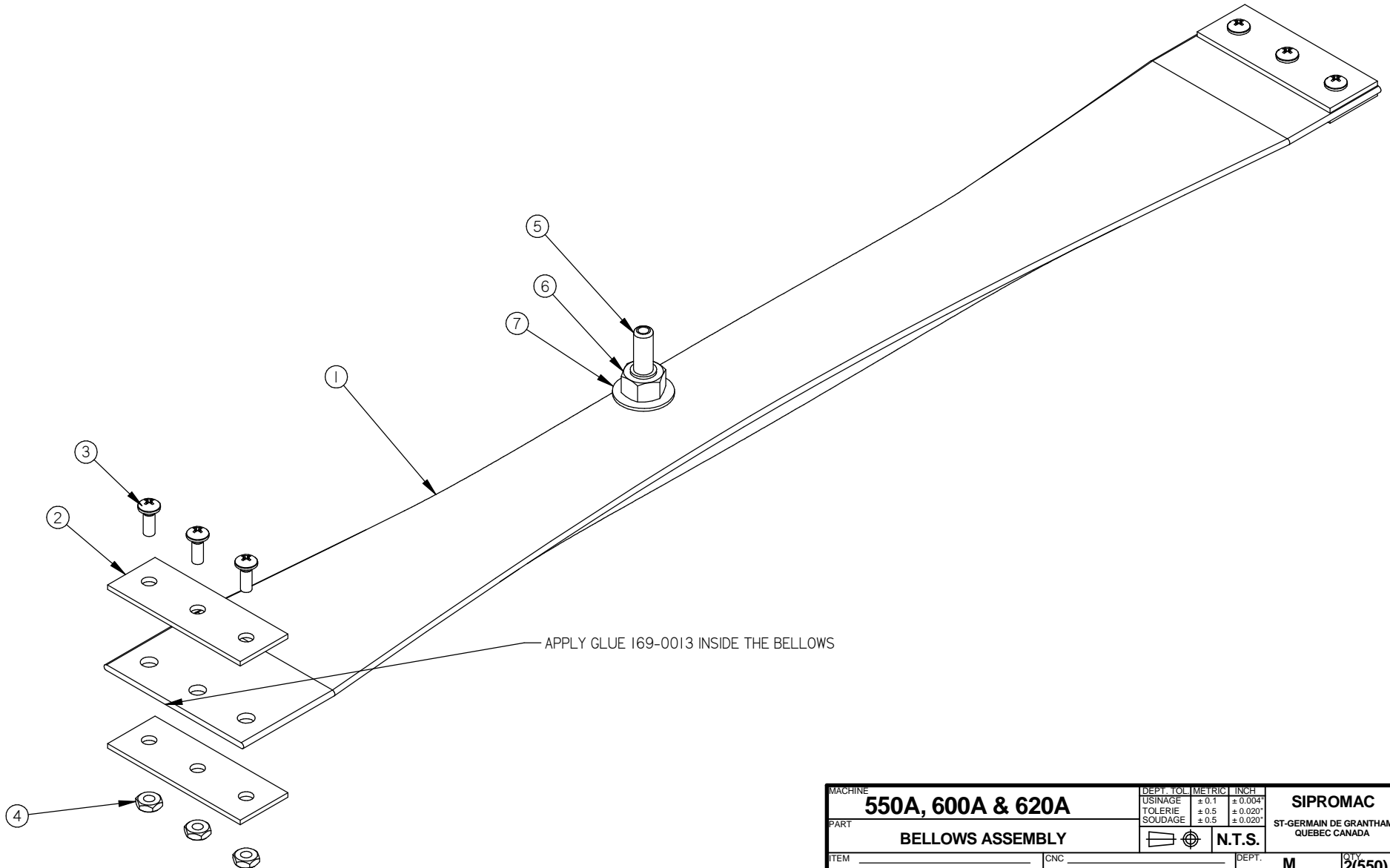

LET.	MODIFICATION	DATE	INT.
------	--------------	------	------

MACHINE	550A, 600A & 620A		DEPT. TOL. METRIC	INCH	SIPROMAC ST-GERMAIN DE GRANTHAM QUEBEC CANADA
PART	BELLOWS ASSEMBLY		USINAGE ± 0.1 ± 0.004"	TOLERIE ± 0.5 ± 0.020"	
ITEM	CNC	DATE	SOUDAGE ± 0.5 ± 0.020"	N.T.S.	
MAT.	DWG BY S.L.	DATE 13-11-12	APP. BY	DEPT. M	NO. 2(550) 4
				005A1436	

ITEM	PART #	DESCRIPTION	QT.	ITEM	PART #	DESCRIPTION	QT.
19	051-0720	WASHER #8 FLAT S/S	6	1	005D0150	TABLE PRE-ASSEMBLY	1
20	051-0560	NUT #8-32 NYLON LOCK S/S	6	2	008A1953	SPRING	4
21	005-0317	GUIDE ARM AXIS ASS'Y	1	3	002A3941	SPRING ADJ. PIVOT	4
22	051-0783	WASHER 3/8" FLAT THICK S/S	4	4	051-0600	NUT 5/16" -18 S/S	8
23	051-0360	BOLT 3/8"-16nc. X 1" S/S	2	5	002A4002	SPRING ADJ. PIVOT SPACER	8
24	051-0620	NUT 3/8"-16 NC S/S	2	6	051-0760	WASHER 5/16" FLAT S/S	8
25	001A6466	BEARING SPACER	2	7	051-0300	BOLT 5/16"-18 x 3/4" S/S	8
26	051-0142	SCREW 8-32 x1-1/2"RND PHIL S/S	6	8	004A3937	SHACKLE ASS'Y	4
				9	036-0400	WIRE CONNECT. 3/8" NPT CD09/O-RING/NUT	8
				10	004A3968	SPRING INSERT ASSEMBLY	4
				11	002C0318	CENTRAL SHAFT	1
				12	075-1655	2 BOLT FLANGED BEARING 1-1/4" PLASTIC	2
				13	051-0428	BOLT 7/16"-14NC x 1-1/2" SS	4
				14	001A2954	WASHER 0.468"Ø ID x 1.250"OD x 3.5	8
				15	051-0625	NUT 7/16"-14 S/S	4
				16	005A1437	MICRO SWITCH COLLAR ASSY	3
				17	026-0750	ROLLER PLUNGER SWITCH SPDT	3
				18	004B3936	SPRING BLOCK PRE-ASSY	2

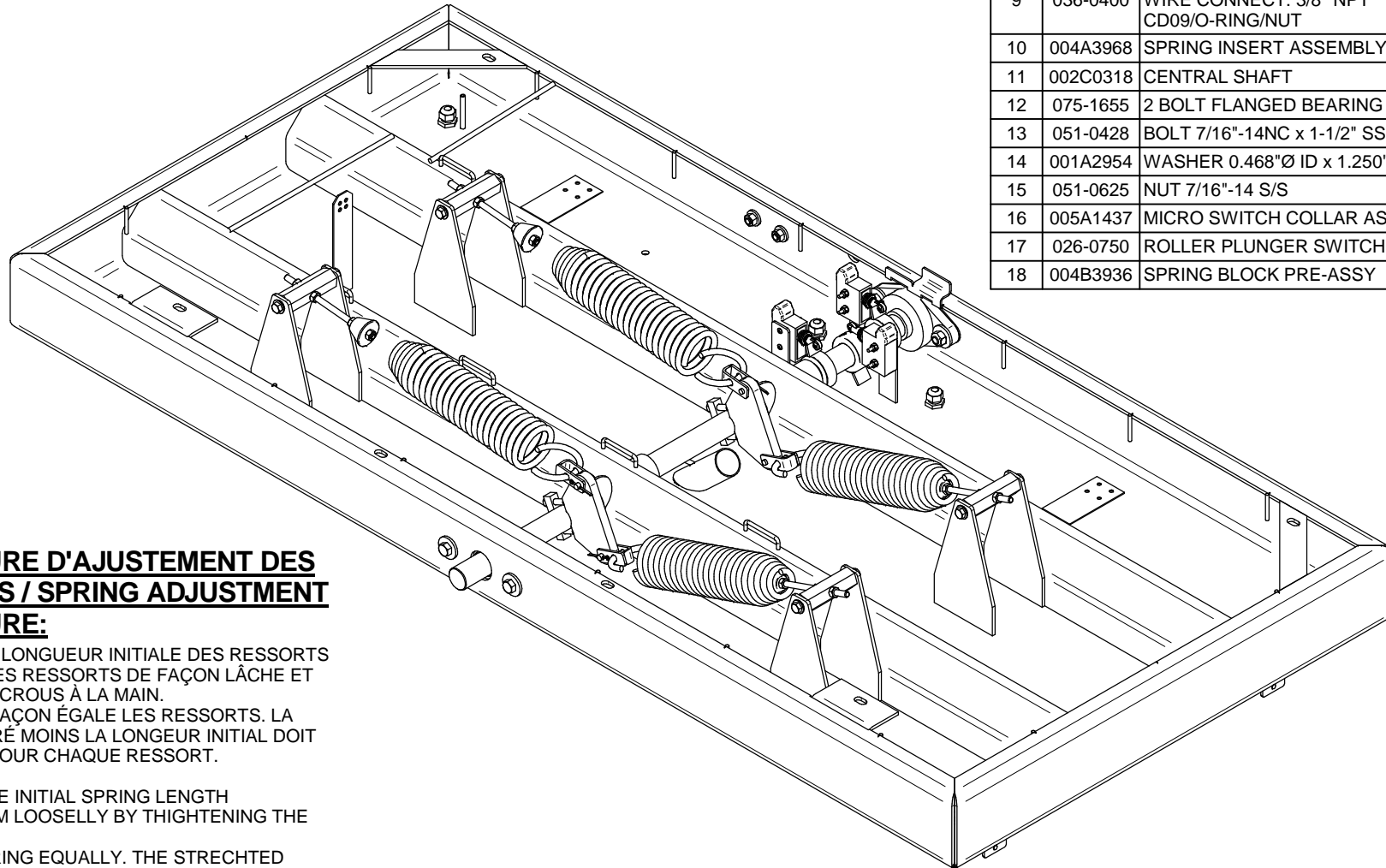

PROCÉDURE D'AJUSTEMENT DES RESSORTS / SPRING ADJUSTMENT PROCEDURE:

- MESURER LA LONGUEUR INITIALE DES RESSORTS
 - INSTALLER LES RESSORTS DE FAÇON LÂCHE ET SERRER LES ÉCROUS À LA MAIN.
 - TENDRE DE FAÇON ÉGALE LES RESSORTS. LA LONGUEUR ÉTIRÉ MOINS LA LONGUEUR INITIAL DOIT ÊTRE ÉGALE POUR CHAQUE RESSORT.
-
- MEASURE THE INITIAL SPRING LENGTH
 - INSTALL THEM LOOSELY BY THIGHTENING THE NUT BY HAND
 - TENSION SPRING EQUALLY. THE STRECHTED LENGTH MINUS THE INITIAL LENGTH MUST BE THE SAME ON EACH SPRING.

H	005D0150 WAS 005C0150	13-12-02	SBU
LET.	MODIFICATION	DATE	INT.

MACHINE	600A		DEPT. TOL. METRIC	INCH	SIPROMAC ST-GERMAIN DE GRANTHAM QUEBEC CANADA
PART	TABLE ASSEMBLY		USINAGE ± 0.1 ± 0.004	TOLERIE ± 0.5 ± 0.020	
ITEM	CNC	DEPT.	SOUDEGE ± 0.5 ± 0.020	N.T.S.	
MAT.	DWG BY SBU	DATE 13-12-02	NO.	M-(M)	QTY. 1
	APP. BY	DATE	004D0122		

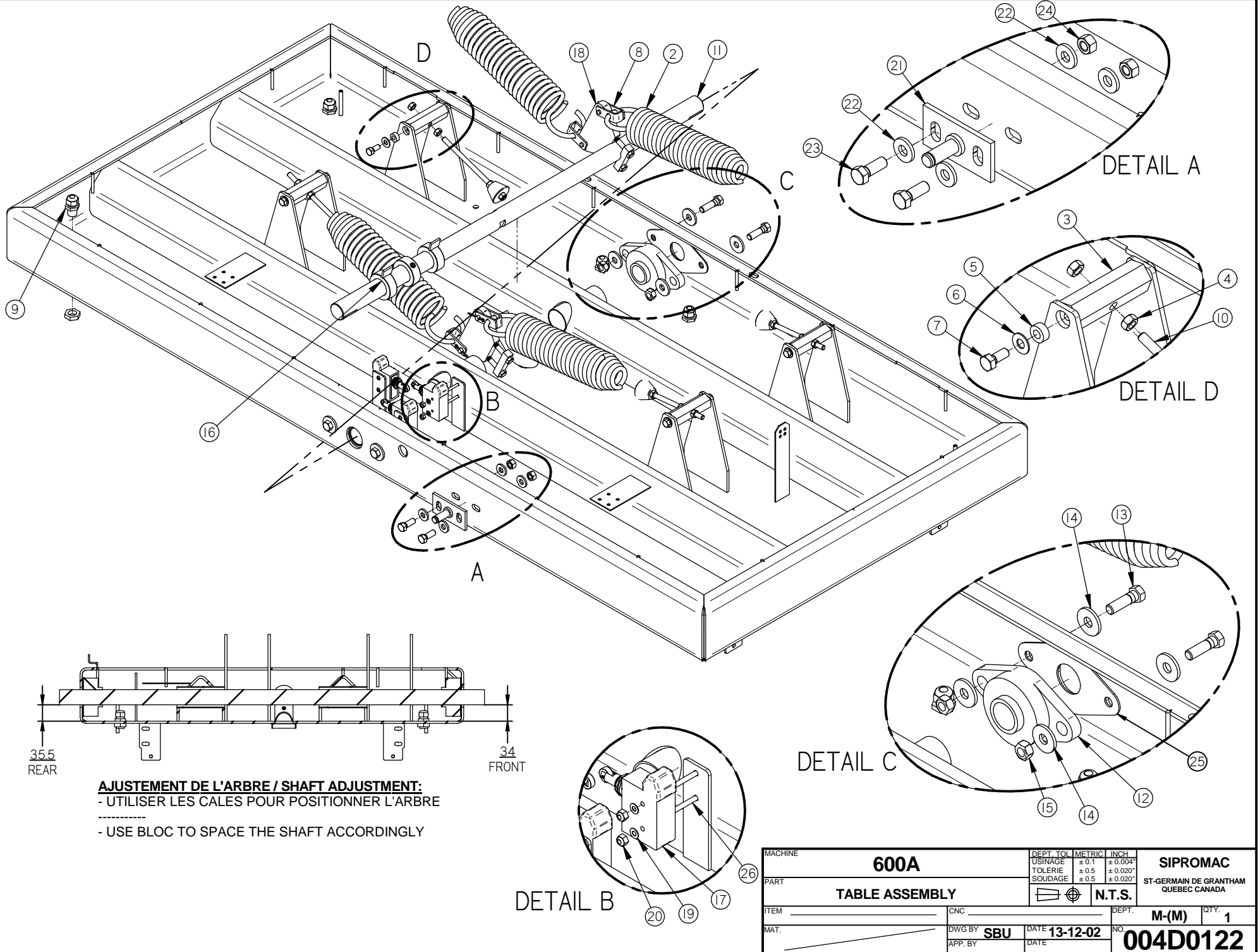

AJUSTEMENT DE L'ARBRE / SHAFT ADJUSTMENT:
 - UTILISER LES CALES POUR POSITIONNER L'ARBRE

 - USE BLOC TO SPACE THE SHAFT ACCORDINGLY

MACHINE	600A		DEPT. TOL. METRIC	INCH	SIPROMAC ST-GERMAIN DE GRANTHAM QUEBEC CANADA
PART	TABLE ASSEMBLY		USINAGE	± 0.1 ± 0.004"	
ITEM	CNC		TOLERIE	± 0.5 ± 0.020"	
MAT.	APP. BY	DATE	SOUDEGE	± 0.5 ± 0.020"	N.T.S.
	DWG BY SBU	DATE 13-12-02			DEPT. M-(M) QTY. 1
	APP. BY	DATE			004D0122

004B3936

ITEM	PART #	DESCRIPTION	QT.
1	002B4058	SPRING BLOCK	1
2	075-0015	BUSHING PL.5/16" x 1/2" x 1/2"	2
3	002B3939	UPPER SPRING BLOCK	1
4	051-0312	S/S BOLT 5/16" - 18NC. 2 1/4"	2

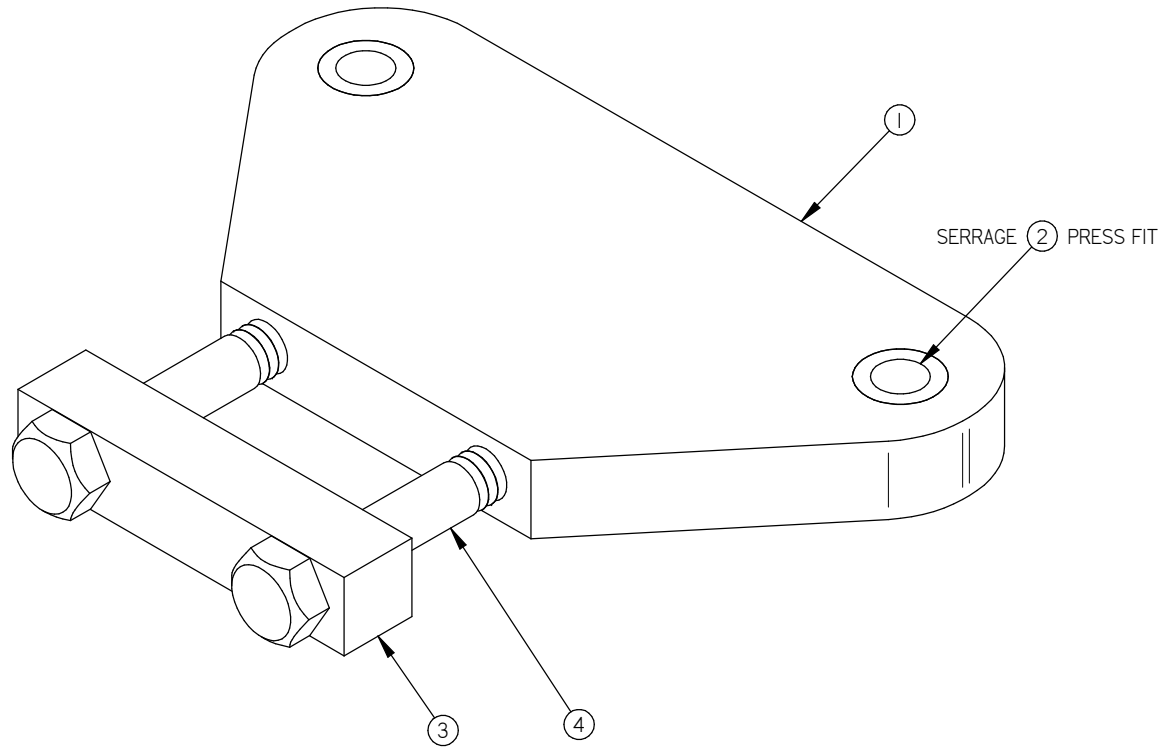

620A	2
600A	2
MACHINE	QTY

MACHINE		VACCUM		DEPT. TOL.	METRIC	INCH	SIPROMAC ST-GERMAIN DE GRANTHAM QUEBEC CANADA
PART		SPRING BLOCK PRE-ASSY		USINAGE	± 0.1	± 0.004"	
ITEM		CNC		TOLERIE	± 0.5	± 0.020"	
MAT.		DWG BY J.G.		DATE	13-01-15	NO.	U-(M) QTY LISTE 004B3936
LET.		APP. BY		DATE			

B	AJOUTER 620A	13-01-23	J.G.
A	REDESSINE	13-01-15	J.G.
LET.	MODIFICATION	DATE	INT.

004A3968

ITEM	PART #	DESCRIPTION	QT.
1	002A3989	SPRING ADJUSTMENT ROD	1
2	051-0600	NUT 5/16" -18 S/S	2
3	002B3940	SPRING INSERT	1

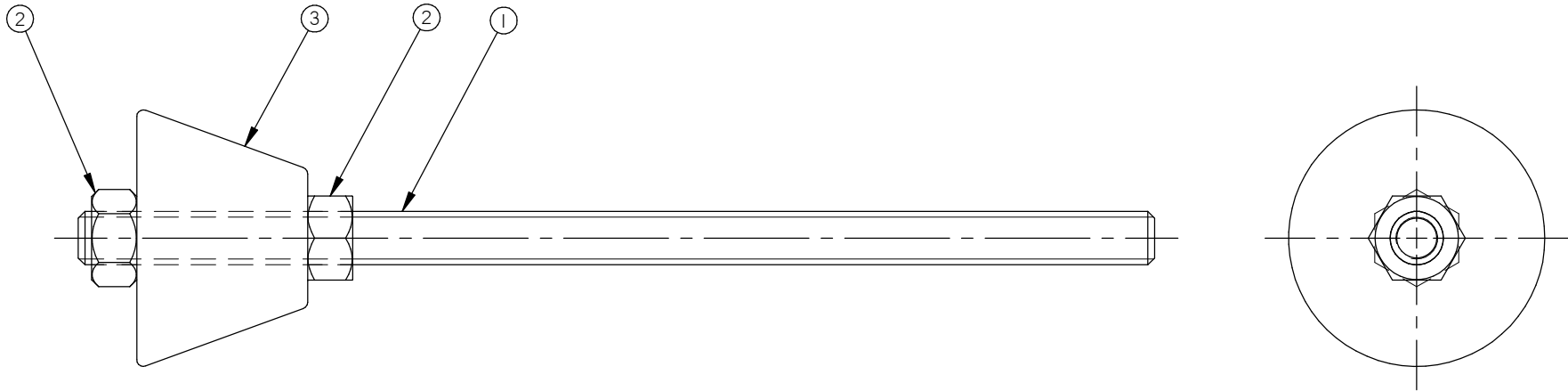

620A	4
600A	4
MACHINE	QTY

MACHINE		600A & 620A		DEPT. TOL.	METRIC	INCH	SIPROMAC ST-GERMAIN DE GRANTHAM QUEBEC CANADA
PART		SPRING INSERT ASSEMBLY		USINAGE	± 0.1	± 0.004"	
ITEM		CNC		TOLERIE	± 0.5	± 0.020"	
MAT.		DWG BY J.G.		DATE	13-01-15		N.T.S.
LET.		APP. BY		DATE			M-(M) QTY LISTE
						004A3968	

A	AJOUTER 620A	13-01-23	J.G.
LET.	MODIFICATION	DATE	INT.

004A3937

ITEM	PART #	DESCRIPTION	QT.
1	004A3935	SHACKLE PRE-ASS'Y	1
2	001A6269	SHACKLE PLATE	1
3	056-0118	COTTER PIN 3/32" x 1" S/S	1

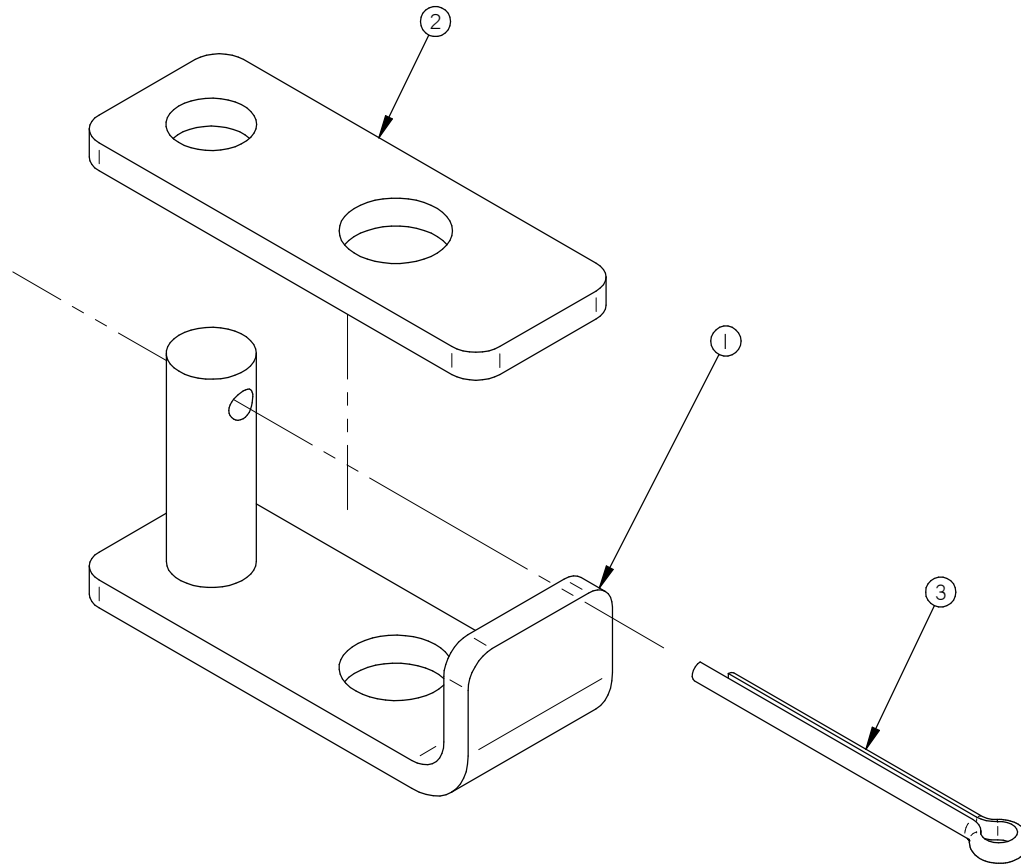

600A	4
MACHINE	QTY

MACHINE		VACUUM		DEPT. TOL.	METRIC	INCH.	SIPROMAC ST-GERMAIN DE GRANTHAM QUEBEC CANADA
PART		SHACKLE ASS'Y		USINAGE	± 0.1	± 0.004"	
ITEM		CNC		TOLERIE	± 0.5	± 0.020"	
MAT.		DWG BY J.G.		DATE	12-11-06		M-(M) QTY LISTE 004A3937
LET.		MODIFICATION		DATE	INT.		

LET.	MODIFICATION	DATE	INT.
------	--------------	------	------

004A4098

ITEM	PART #	DESCRIPTION	QT.	ITEM	PART #	DESCRIPTION	QT.
11	051-0580	NUT 1/4"-20 S/S	4	1	004A4099	E-BOX PRE-ASSY	1
12	051-0210	BOLT 1/4"-20nc. X 1" S/S	4	2	056-3010-1	HINGE CONCEALED SS304 - BASE	2
13	051-0581	NUT 1/4"-20 NYLON LOCK S/S	4	3	056-3010-3	HINGE CONCEALED SS304 - PIN	2
14	051-0139	SCREW 10-24 x 1/2" FLAT PHIL S/S	4	4	004A4102	E-BOX FALSE BOTTOM	1
15	028-0105	GROUND BARRIER (6 HOLES)	1	5	036-0430	PRESSE-ÉTOUPE CD29	1
16	051-0128	SCREW 10-24 x 3/8" TRUSS PHIL S/S	4	6	036-0409	PRESSE-ÉTOUPE CD13	3
				7	004A4100	E-BOX DOOR ASSEMBLY	1
				8	036-0420	PRESSE-ÉTOUPE CD21	2
				9	036-0440	PRESSE-ÉTOUPE CD36	1
				10	051-0600	NUT 5/16" -18 S/S	4

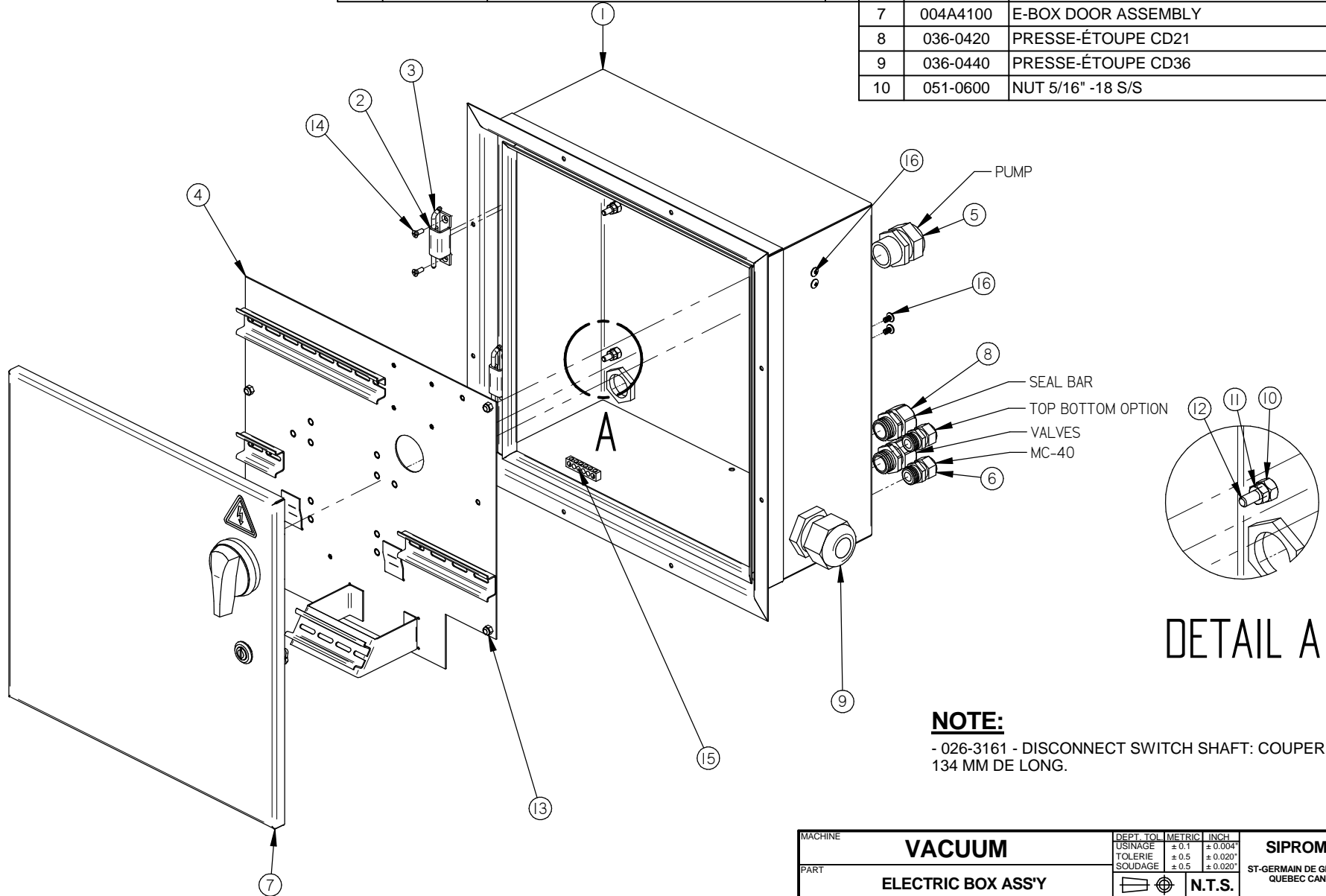

NOTE:

- 026-3161 - DISCONNECT SWITCH SHAFT: COUPER À 134 MM DE LONG.

LET.	MODIFICATION	DATE	INT.
------	--------------	------	------

MACHINE		VACUUM		DEPT. TOL	METRIC	INCH	SIPROMAC ST-GERMAIN DE GRANTHAM QUEBEC CANADA
PART		ELECTRIC BOX ASS'Y		USINAGE	± 0.1	± 0.004"	
ITEM		CNC		TOLERIE	± 0.5	± 0.020"	
MAT.		APP. BY		DATE		NO.	1
		SBU		13-09-23		004A4098	

004A4100

ITEM	PART #	DESCRIPTION	QT.
1	004A4101	E-BOX DOOR PRE-ASSY	1
2	056-2612	CAM LOCK QUARTER TURN SS304	1
3	179-0026	D-SHAPED RUBBER SEAL 1683mm LONG	1
4	026-3160	HANDLE RED/YELLOW NEMA 4X, COMPACT, PADLOCKABLE	1
5	127-0100	STICKER ELEC.HAZARD ISO 2-1/2" TRIANGLE	1

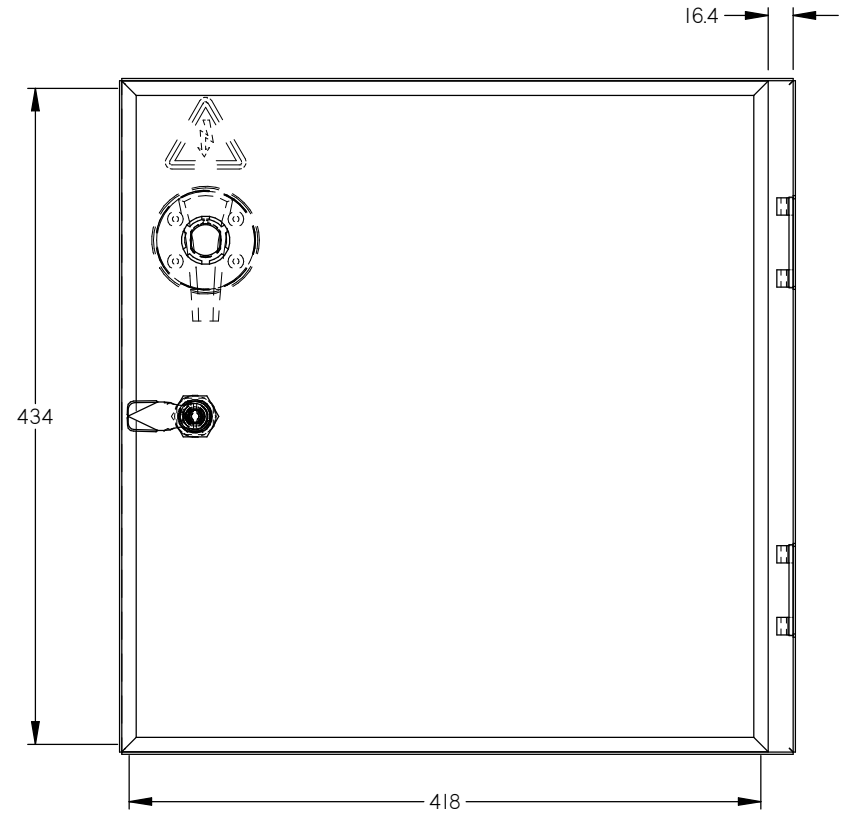
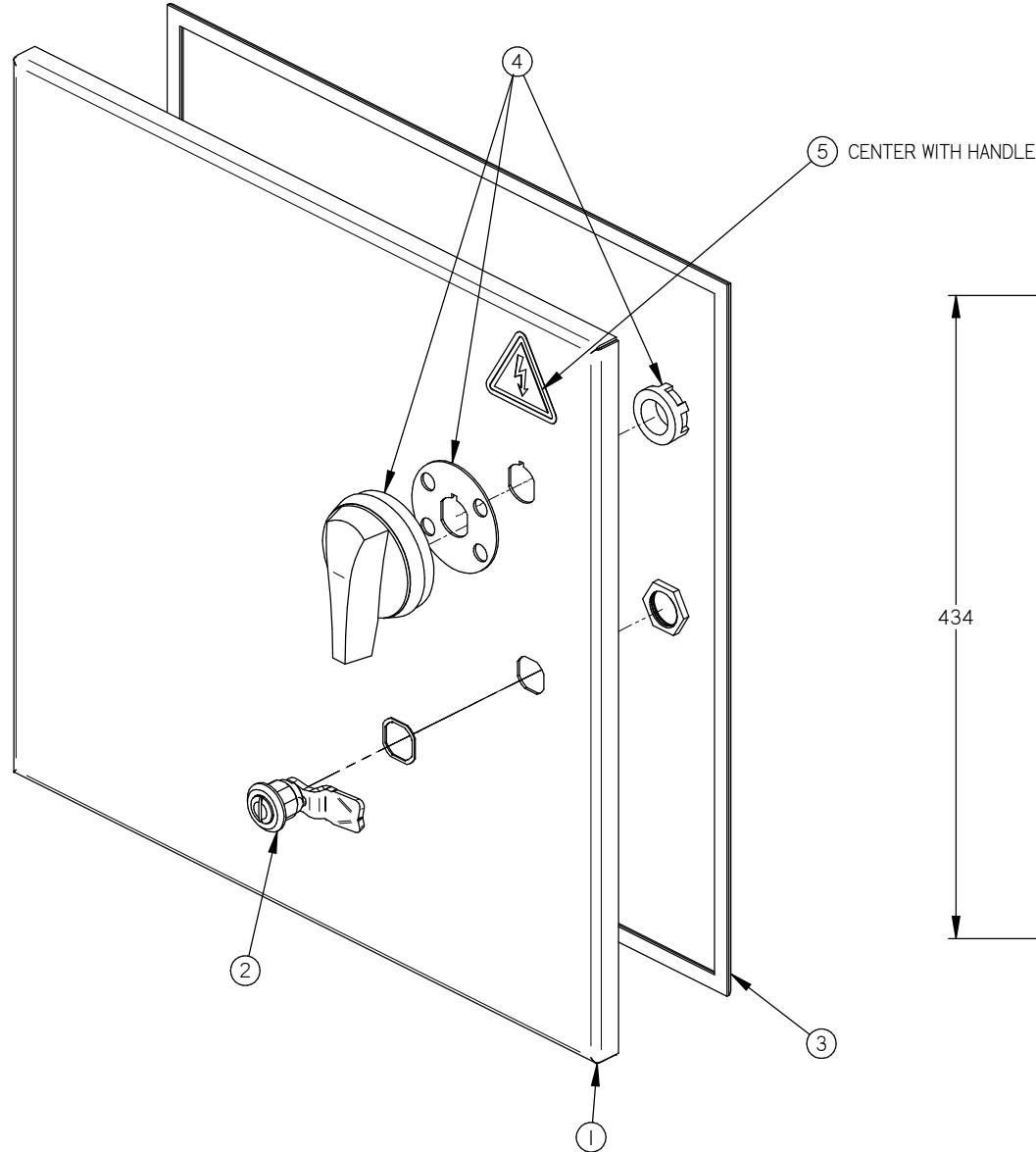

MACHINE		VACUUM		DEPT. TOL.	METRIC	INCH	SIPROMAC ST-GERMAIN DE GRANTHAM QUEBEC CANADA
PART		E-BOX DOOR ASSEMBLY		USINAGE	± 0.1	± 0.004"	
ITEM		CNC		TOLERIE	± 0.5	± 0.020"	
MAT.		APP. BY SBU		DATE	13-09-17	NO.	004A4100
LET.		MODIFICATION		DATE		INT.	DEPT. M QTY. 1

LET.	MODIFICATION	DATE	INT.
------	--------------	------	------

004A4097

ITEM	PART #	DESCRIPTION	QT.
1	004A4096	RIGHT REAR ACCESS DOOR PRE-ASSY	1
2	056-2600	SPRING PAWL LATCHE SS KNOB	2
3	051-0071	SCREW 4-40 x 1/4" RND SLOT S/S	4
4	051-0541	NUT # 4-40 NYLON LOCK SS	4

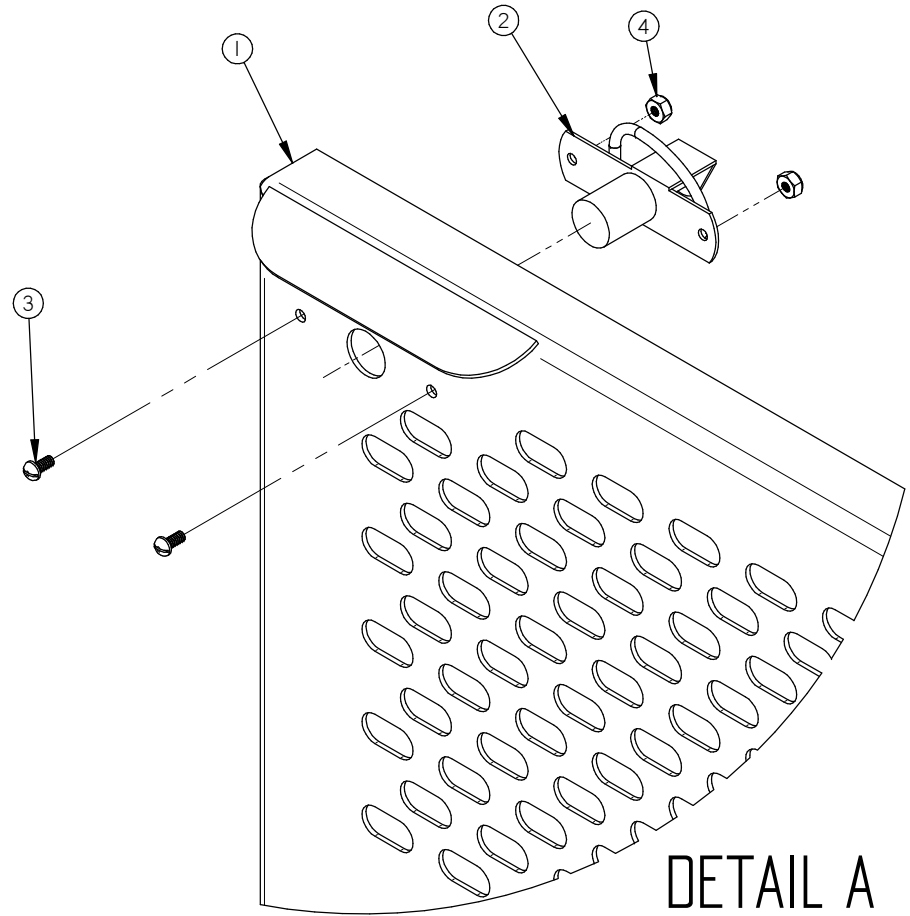
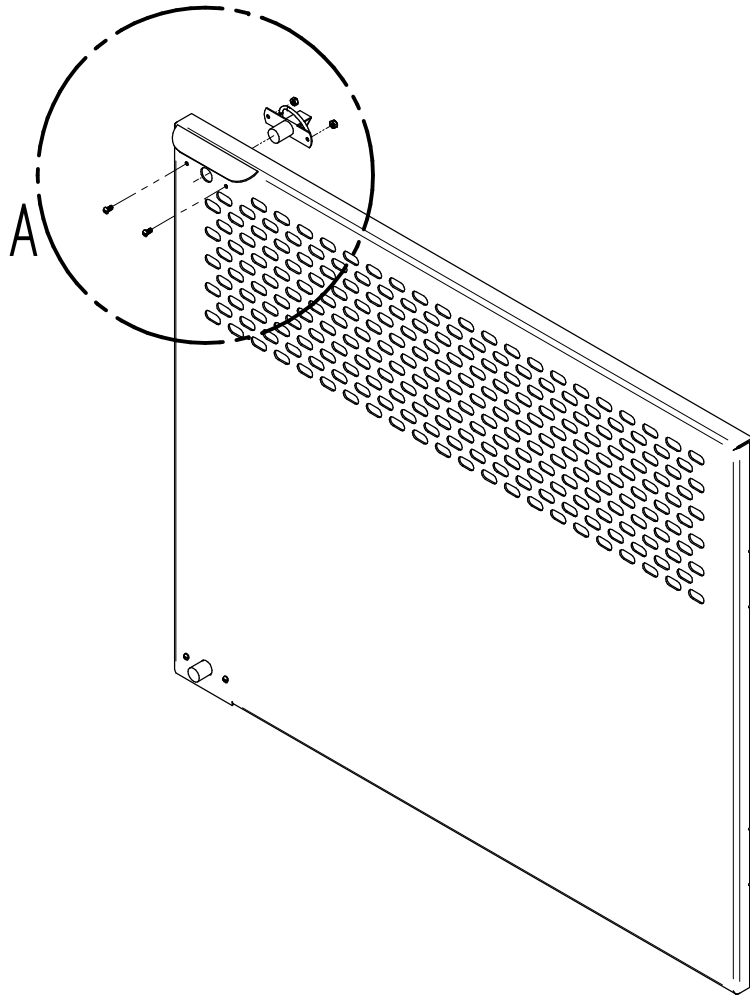

DETAIL A

LET.	MODIFICATION	DATE	INT.
------	--------------	------	------

MACHINE		600A & 620A		DEPT. TOL.	METRIC	INCH	SIPROMAC ST-GERMAIN DE GRANTHAM QUEBEC CANADA
PART		RIGHT REAR ACCESS DOOR ASSY		USINAGE	± 0.1	± 0.004"	
				TOLERIE	± 0.5	± 0.020"	
ITEM		CNC		SOUDEAGE	± 0.5	± 0.020"	N.T.S.
MAT.		DWG BY SBU		DATE 13-09-16		NO. 004A4097	
		APP. BY		DATE		DEPT. M QTY. 1	

005A0560

ITEM	PART #	DESCRIPTION	QT.
1	005A0418	SEAL BAR PRE-ASS'Y	1
2	051-0251	CAP. HEX. SKT BOLT 1/4"-20 NC. x 1 1/2"	4
3	051-0581	NUT 1/4"-20 NYLON LOCK S/S	9
4	051-0230	HEX BOLT 1/4-20 x 1 1/4" SS	5
5	051-0250	BOLT 1/4"-20nc. X 1 1/2" S/S	4
6	051-0740	WASHER 1/4" FLAT S/S	8
7	001-1591	EXTERIOR BELLOWS COVER	1
8	002A4162	SEAL BAR SUPPORT	1
9	001-1958	INTERIOR BELLOWS COVER	1
10	001-0269	SEAL BAR GUIDE	2

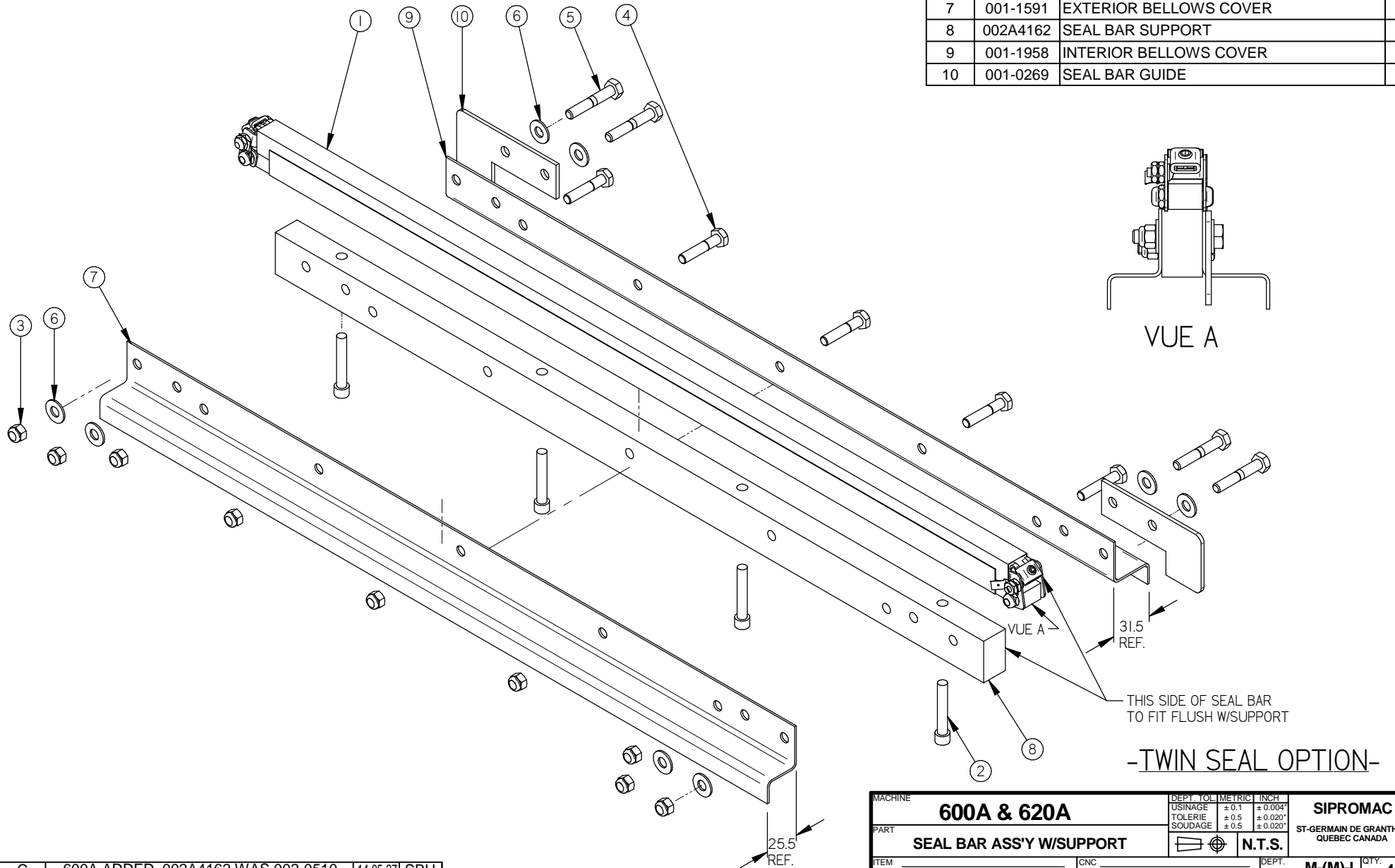

VUE A

-TWIN SEAL OPTION-

C	600A ADDED, 002A4162 WAS 002-0510	14-05-27	SBU
B	REDRAWN	05-09-12	M.A.
LET.	MODIFICATION	DATE	INT.

MACHINE		DEPT. TOL. METRIC		DEPT.	
600A & 620A		USINAGE	± 0.1	± 0.004"	SIPROMAC
PART		TOLERIE	± 0.5	± 0.020"	ST-GERMAIN DE GRANTHAM
SEAL BAR ASS'Y W/SUPPORT		SOUDAGE	± 0.5	± 0.020"	QUEBEC CANADA
ITEM		CNC		N.T.S.	
MAT.		DWG BY M.A.L.		M-(M)-I	
		DATE 05-09-12		QTY. 4	
		APP. BY		NO. 005A0560	

005A0418

ITEM	PART #	DESCRIPTION	QT.
1	002A0400	SEAL BAR	1
2	039-0268	DOUBLE SEAM BAND (8MM) (2.4)	1
3	176-0200	TEFLON TAPE 5MIL (0.81)	1
4	056-1401	3/8"SET SCREW BANDING BUCKLE S/S	2
5	052-0393	SCREW 1/4-28x3/16"SKT SET OVAL POINT ZINC	2
6	051-0100	SCREW 8-32 X 3/8" PAN PHIL S/S	2
7	051-0550	NUT #8-32 SS	4
8	027-0400	CONNECTOR ADAPTOR	2
9	001A2742	8mm ELEMENT BINDER	2
10	051-0146	SCREW 10-24 X 1" PAN PHIL S/S	2
11	051-0572	NUT #10-24 NYLON LOCK S/S	2
12	171-0180	TAPE CLEAR SUPER BOND 3/4" 641.5mm (0.019)	2
13	077-0095	SPRING C 0360-059-1250 S/S	2

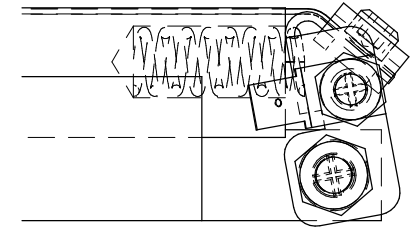
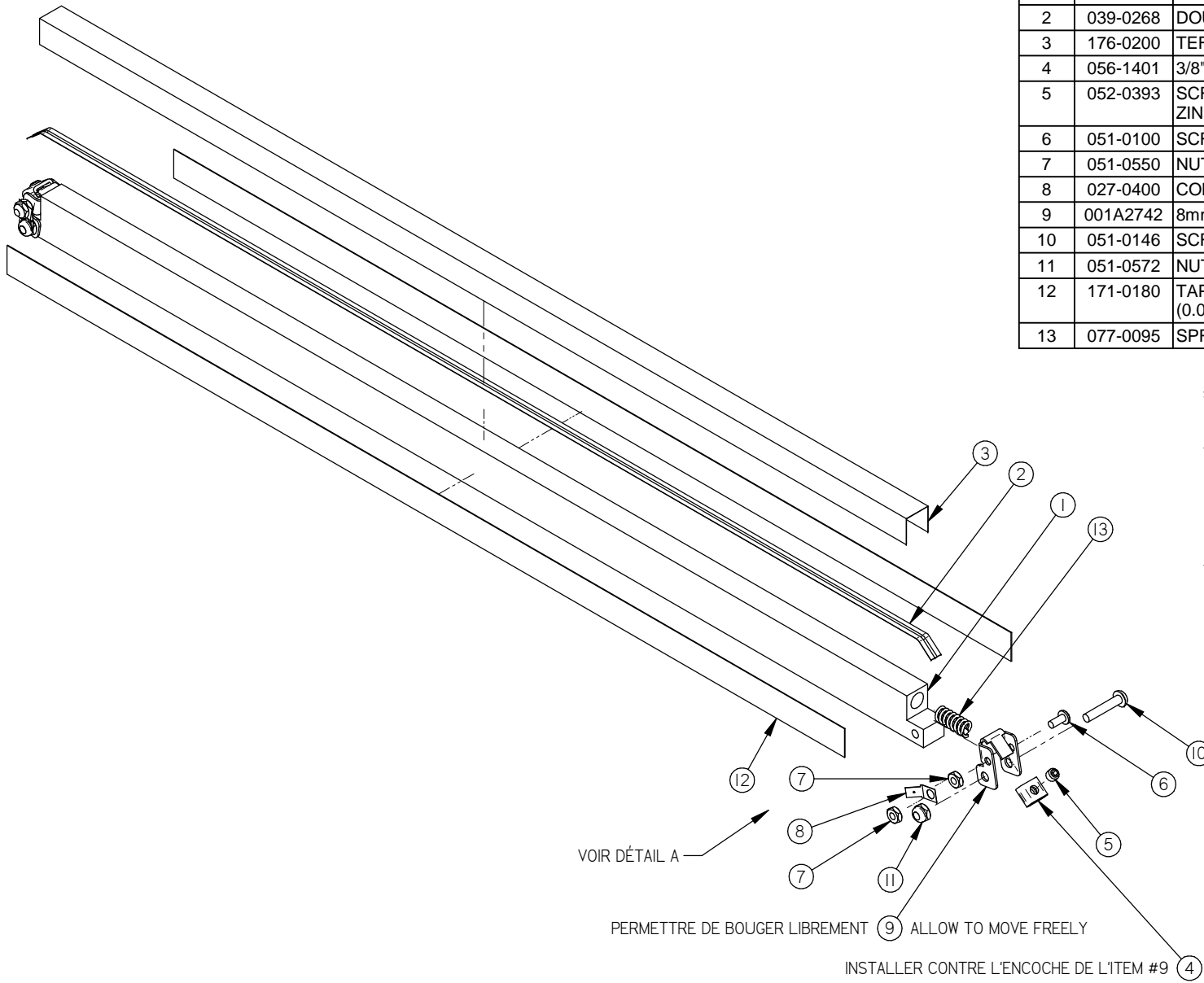

-DÉTAIL A-

VOIR DÉTAIL A

PERMETTRE DE BOUGER LIBREMENT 9 ALLOW TO MOVE FREELY

INSTALLER CONTRE L'ENCOCHE DE L'ITEM #9 4 INSTALL AGAINST NOTCH OF ITEM #9

-TWIN SEAL OPTION-

H	600A ADDED	14-05-27	SBU
G	MODIF. A-453 AJOUTER 077-0095	10-06-01	J.G.
F	ADDED 052-0393	06-04-19	M.A.
E	REDRAWN	05-09-12	M.A.
LET.	MODIFICATION	DATE	INT.

MACHINE	600A & 620A		DEPT. TOL. METRIC	INCH	SIPROMAC ST-GERMAIN DE GRANTHAM QUEBEC CANADA
PART	SEAL BAR PRE-ASS'Y		USINAGE ± 0.1 ± 0.004	TOLERIE ± 0.5 ± 0.020	
ITEM	CNC		SOUDEGE ± 0.5 ± 0.020	N.T.S.	
MAT.	DWG BY M.A.L.	DATE 05-09-12	NO.	M-(M)-I	QTY. 4
	APP. BY	DATE		005A0418	

005F0561

ITEM	PART #	DESCRIPTION	QT.
5	001-0269	SEAL BAR GUIDE	2
3	001-1591	EXTERIOR BELLOWS COVER	1
4	001-1958	INTERIOR BELLOWS COVER	1
2	002A4191	SEAL BAR SUPPORT (ECO)	1
1	005F0419	SEAL BAR PRE-ASS'Y	1
8	051-0230	HEX BOLT 1/4-20 x 1 1/4" SS	5
7	051-0250	BOLT 1/4"-20nc. X 1 1/2" S/S	4
10	051-0251	CAP. HEX. SKT BOLT 1/4"-20 NC. x 1 1/2"	4
9	051-0581	NUT 1/4"-20 NYLON LOCK S/S	9
6	051-0740	WASHER 1/4" FLAT S/S	8

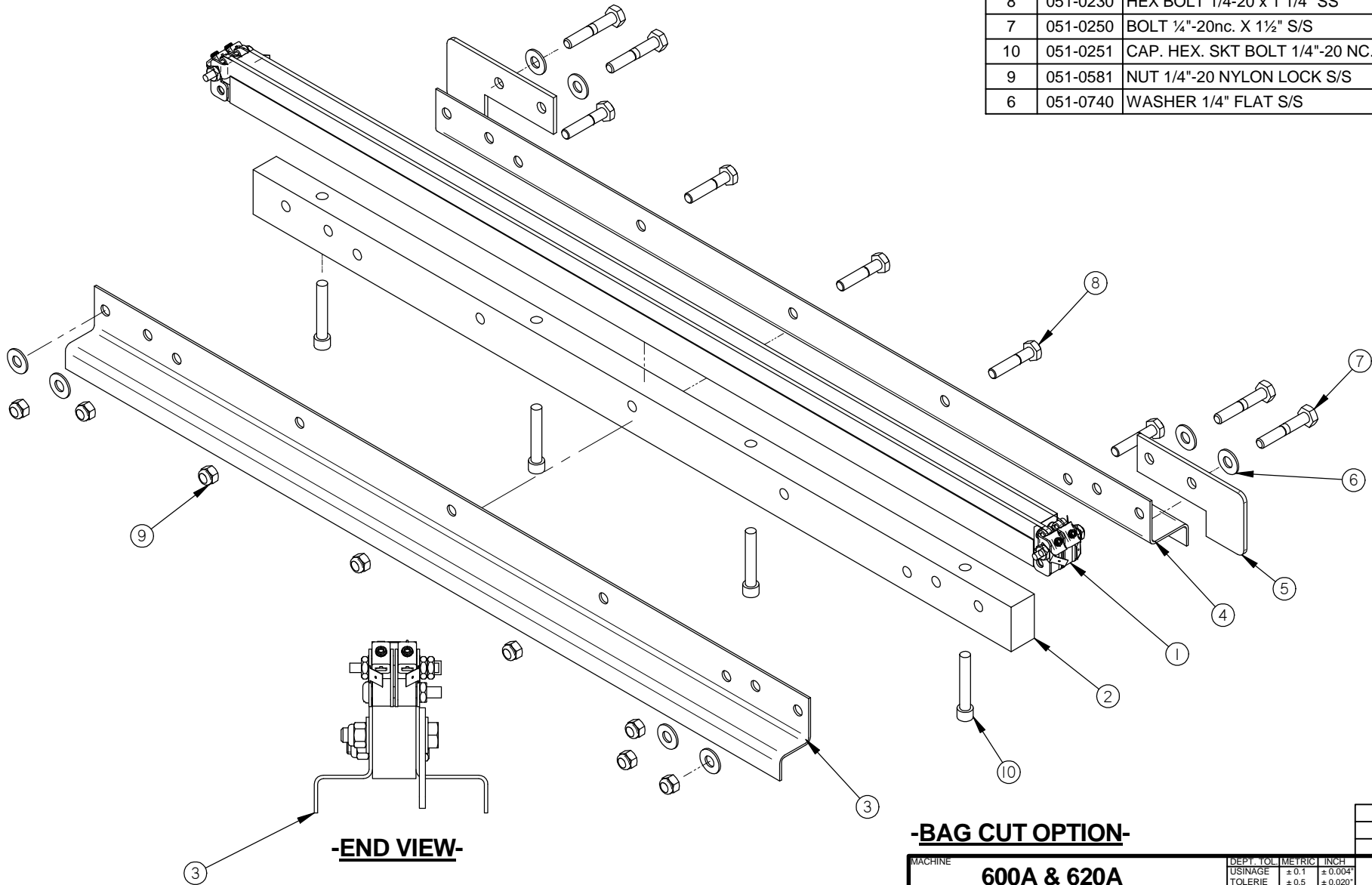

-END VIEW-

-BAG CUT OPTION-

620A	4
600A	4
MACHINE	QTY

MACHINE		DEPT. TOL. METRIC		INCH		SIPROMAC	
600A & 620A		USINAGE	± 0.1	± 0.004"	ST-GERMAIN DE GRANTHAM QUEBEC CANADA		
PART		TOLERIE	± 0.5	± 0.020"			
SEAL BAR ASS'Y W/SUPPORT (ECO)		SOUDAGE	± 0.5	± 0.020"			
ITEM		CNC	N.T.S.		M-I		QTY. 4
MAT.		DWG BY Y.F.	DATE 14-02-19	NO. 005F0561			
		APP. BY	DATE				

H	600A ADDED	14-05-27	SBU
G	005D0153 WAS 005C0153	13-11-06	SBU
LET.	MODIFICATION	DATE	INT.

005F0419

ITEM	PART #	DESCRIPTION	QT.
1	002A4172	BANDING BUCKLE	4
2	002A4190	SEAL BAR (ECO)	1
3	005A1443	ELEMENT BINDER RIGHT ECO	2
4	005A1444	ELEMENT BINDER LEFT ECO	2
5	027-0400	CONNECTOR ADAPTOR	6
6	039-02115	ROUND CUT-OFF ELEMENT 0.9MM	1
7	039-0222	TAPERED BAND 3MM X 0.3MM	1
8	051-0154	SCREW 10-24 x 1-1/4" PAN SLOT S/S	2
9	051-01752	SET SCREW 10-32 SS 3/16"	2
10	051-01752	SET SCREW 10-32 SS 3/16"	2
11	051-0550	NUT #8-32 SS	8
12	077-0014	SPRING C0240-040-1250 SS COMP.	4
13	171-0180	TAPE CLEAR SUPER BOND 3/4" 663.5mm (0.021)	2
14	176-0200	TEFLON TAPE 5MIL	1
15	176-0203	TEFLON TAPE UNCOATED ZONE 5MIL	1

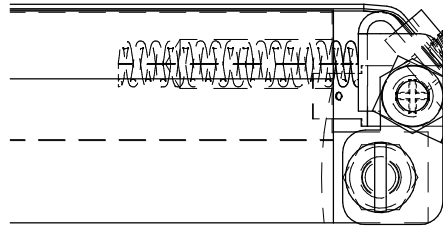

-DÉTAIL A-

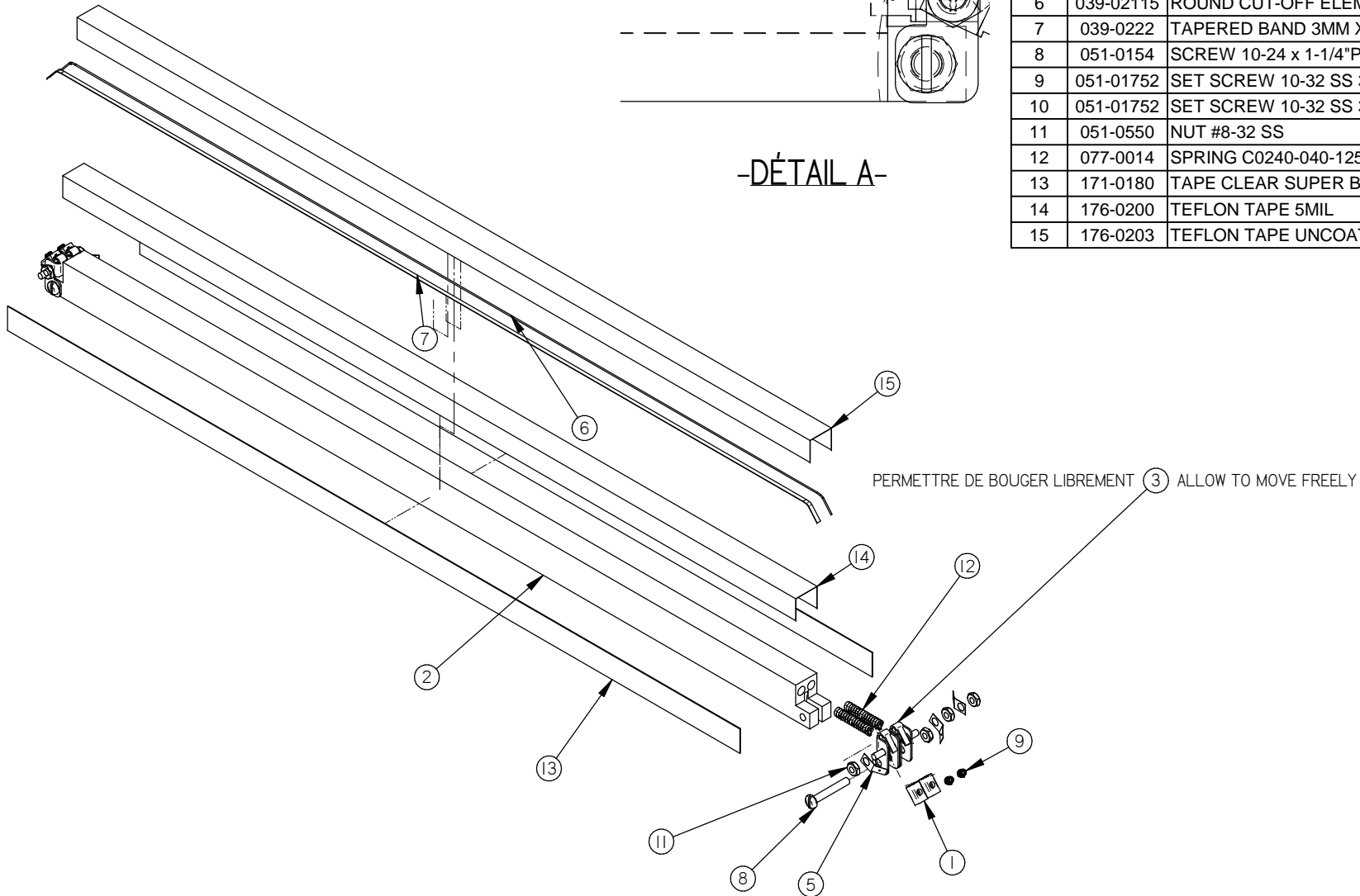

-BAG CUT (ECO) -

620A	4
600A	4
MACHINE	QTY

MACHINE	600A & 620A		DEPT. TOL. METRIC	INCH	SIPROMAC ST-GERMAIN DE GRANTHAM QUEBEC CANADA
PART	SEAL BAR PRE-ASS'Y		USINAGE ± 0.1 ± 0.004"	TOLERIE ± 0.5 ± 0.020"	
			SOUDAGE ± 0.5 ± 0.020"		
ITEM	CNC	DEPT.	N.T.S.		M-I
MAT.	DWG BY Y.F.	DATE 14-02-19	NO. 005F0419		LISTE
	APP. BY	DATE			

A	600A ADDED	14-05-27	SBU
LET.	MODIFICATION	DATE	INT.

005B0562

ITEM	PART #	DESCRIPTION	QT.
1	005B0420	SEAL BAR PRE-ASS'Y	1
2	051-0256	BOLT 1/4"-20nc. X 1 3/4" CAP SKT S/S	4
3	051-0581	NUT 1/4"-20 NYLON LOCK S/S	9
4	051-0230	HEX BOLT 1/4-20 x 1 1/4" SS	5
5	051-0250	BOLT 1/4"-20nc. X 1 1/2" S/S	4
6	051-0740	WASHER 1/4" FLAT S/S	8
7	001-1591	EXTERIOR BELLOWS COVER	1
8	002A4162	SEAL BAR SUPPORT	1
9	001-1958	INTERIOR BELLOWS COVER	1
10	001-0269	SEAL BAR GUIDE	2

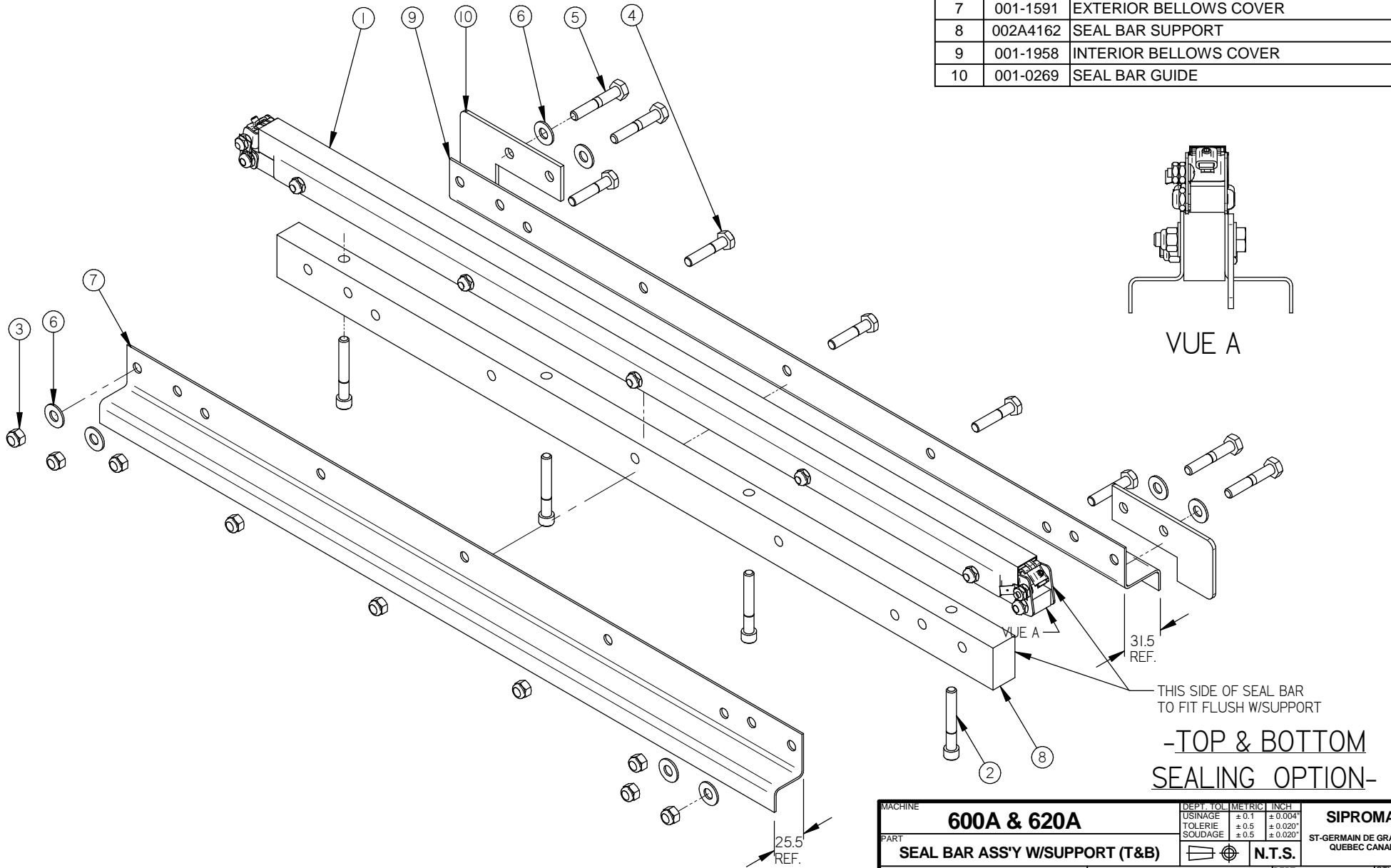

C	600A ADDED, 002A4162 WAS 002-0510	14-05-27	SBU
B	005B0420 WAS 005A0420	13-09-25	SBU
LET.	MODIFICATION	DATE	INT.

MACHINE		600A & 620A		DEPT. TOL. METRIC	INCH	SIPROMAC ST-GERMAIN DE GRANTHAM QUEBEC CANADA	
PART		SEAL BAR ASS'Y W/SUPPORT (T&B)		USINAGE	± 0.1		± 0.004"
ITEM		CNC		TOLERIE	± 0.5		± 0.020"
MAT.		APP. BY		DATE		N.T.S.	
		DWG BY SBU		DATE 13-09-25		DEPT. M-I	
		APP. BY		DATE		NO. 005B0562	
						QTY. 4	

| 005B0420

ITEM	PART #	DESCRIPTION	QT.
1	002A4147	SEAL BAR	1
2	001-2666	ELEMENT BINDER	2
3	051-0146	SCREW 10-24 X 1" PAN PHIL S/S	7
4	051-0572	NUT #10-24 NYLON LOCK S/S	7
5	051-0100	SCREW 8-32 X 3/8" PAN PHIL S/S	2
6	051-0550	NUT #8-32 SS	4
7	027-0400	CONNECTOR ADAPTOR	2
8	179-0003	SILICONE 2mm x 15mm ADHESIVE 664mm (0.664)	1
9	176-0220	TEFLON TAPE, PRESS SENSITIVE 2" (0.081)	1
10	039-0220	BI-ACTIVE SEALING ELEMENT 700mm (0.07)	1
11	056-1400	1/4" SET SCREW BANDING BUCKLE S/S	2
12	176-0203	TEFLON TAPE, 5MIL UNCOATED ZONE 663.5mm (0.066)	1
13	077-0095	SPRING C 0360-059-1250 S/S	2
14	001A6582	TEFLON HOLD DOWN PLATE	2

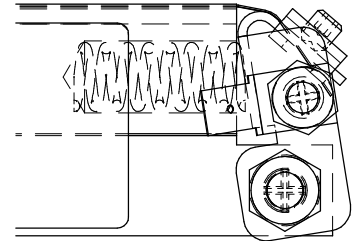
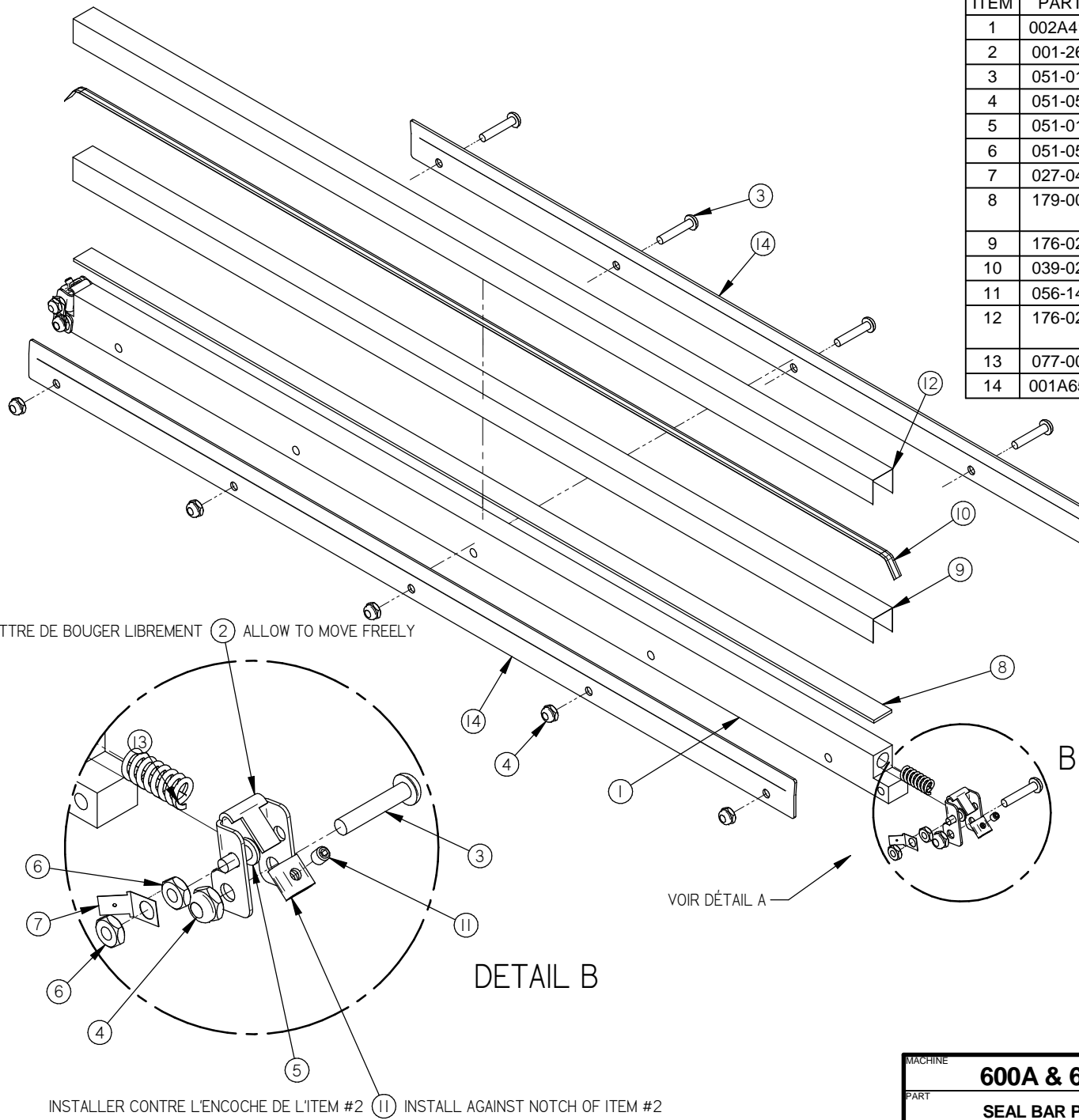

-DÉTAIL A-

PERMETTRE DE BOUGER LIBREMENT (2) ALLOW TO MOVE FREELY

VOIR DÉTAIL A

DETAIL B

INSTALLER CONTRE L'ENCOCHE DE L'ITEM #2 (11) INSTALL AGAINST NOTCH OF ITEM #2

-TOP & BOTTOM SEALING OPTION-

H	600A ADDED	14-05-27	SBU
G	AJOUT TEFLON HOLDER	13-09-25	SBU
LET.	MODIFICATION	DATE	INT.

MACHINE	600A & 620A		DEPT. TOL. METRIC	INCH	SIPROMAC ST-GERMAIN DE GRANTHAM QUEBEC CANADA
PART	SEAL BAR PRE-ASS'Y		USINAGE ± 0.1 ± 0.004	TOLERIE ± 0.5 ± 0.020	
ITEM			SOUDEAGE ± 0.5 ± 0.020	N.T.S.	
MAT.	CNC	DATE	13-09-25	NO.	4
	DWG BY	APP. BY	SBU	DATE	
					005B0420

| 005C0421

ITEM	PART #	DESCRIPTION	QT.
1	002A0536	UPPER SEAL BAR SUPPORT	1
2	002C0401	UPPER SEAL BAR	1
3	051-0232	SCREW 1/4-20x 1-1/4"SKT CAP SS	8
4	001-2666	ELEMENT BINDER	2
5	051-0146	SCREW 10-24 X 1" PAN PHIL S/S	8
6	051-0572	NUT #10-24 NYLON LOCK S/S	8
7	051-0104	SCREW 8-32 x 3/8" RND PHIL S/S	2
8	051-0550	NUT #8-32 SS	4
9	027-0400	CONNECTOR ADAPTOR	2
10	179-0003	SILICONE 2mm x 15mm ADHESIVE 733mm (0.73)	1
11	176-0220	TEFLON TAPE,PRESS.SENSITIVE 2" 733mm (0.089)	1
12	039-0220	BI-ACTIVE SEALING ELEMENT (6mm) 776mm (0.078)	1
13	056-1400	1/4"SET SCREW BANDING BUCKLE S/S	2
14	077-0095	SPRING C 0360-059-1250 S/S	2
15	176-0203	TEFLON TAPE, 5MIL UNCOATED ZONE 733mm (0.089)	1
16	001A6583	UPPER TEFLON HOLDER	2

CE COTÉ DE LA BARRE DOIT ÊTRE ÉGAL AU SUPPORT
THIS SIDE OF SEAL BAR TO FIT FLUSH WITH SUPPORT

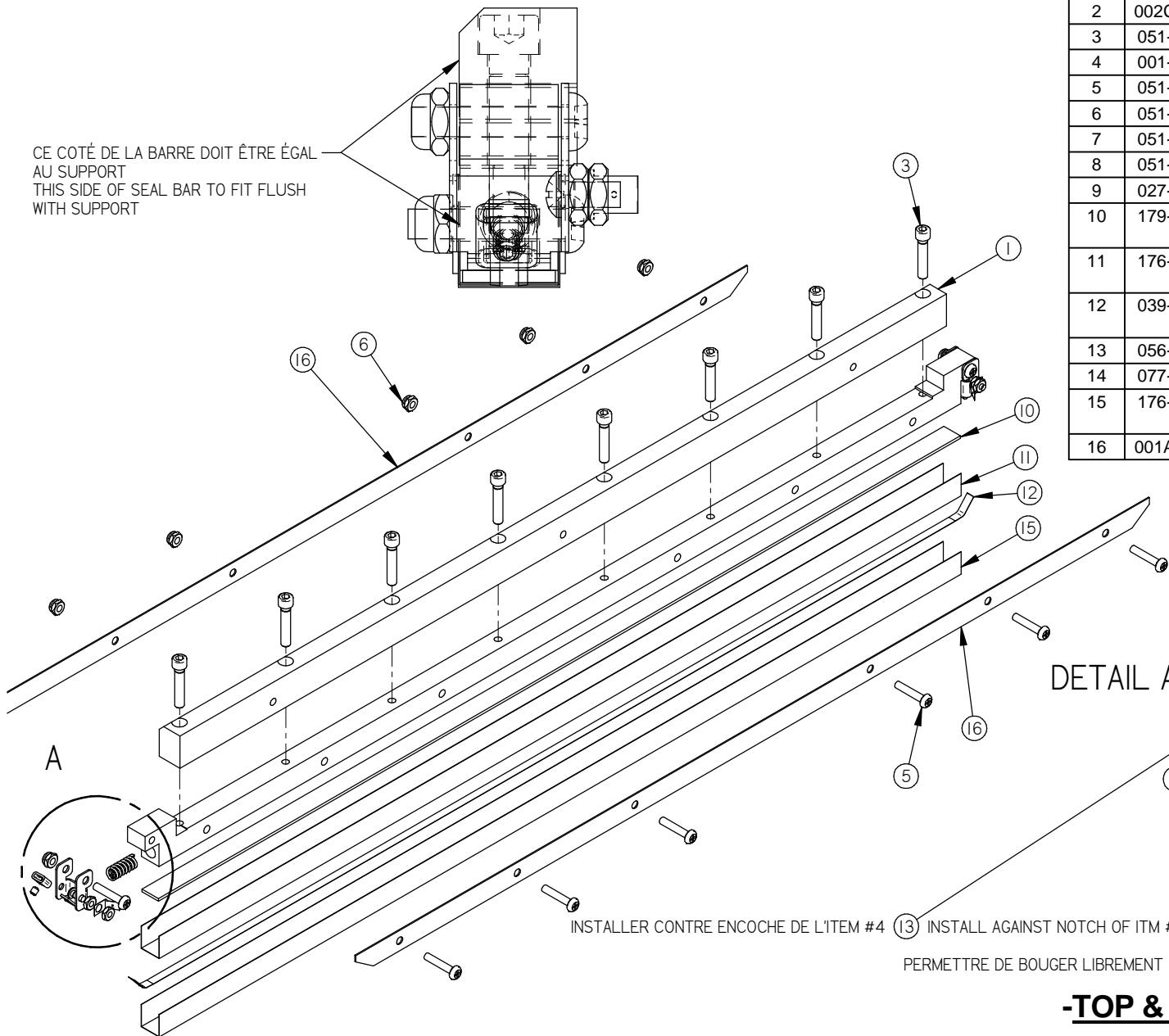

DETAIL A

INSTALLER CONTRE ENCOCHE DE L'ITEM #4 (13) INSTALL AGAINST NOTCH OF ITEM #4

PERMETTRE DE BOUGER LIBREMENT (4) ALLOW TO MOVE FREELY

-TOP & BOTTOM SEALING OPTION-

J	600A ADDED	14-05-27	SBU
H	AJOUT TEFLON HOLDER	13-09-25	SBU
LET.	MODIFICATION	DATE	INT.

MACHINE		600A & 620A		DEPT. TOL. METRIC	INCH	SIPROMAC ST-GERMAIN DE GRANTHAM QUEBEC CANADA
PART		UPPER SEAL BAR ASS'Y W/SUPPORT		USINAGE	± 0.1 ± 0.004	
ITEM		CNC		TOLERIE	± 0.5 ± 0.020	
MAT.		APP. BY		SBU	DATE	13-09-25
						N.T.S.
						M-(M)-I
						QTY. 2
						005C0421

005A1536

ITEM	PART #	DESCRIPTION	QT.
1	004A4247	SEAL BAR SUPPORT (SS)	1
2	005A0418	SEAL BAR PRE-ASS'Y	1
3	051-0210	BOLT 1/4"-20nc. X 1" S/S	4
4	051-0740	WASHER 1/4" FLAT S/S	4

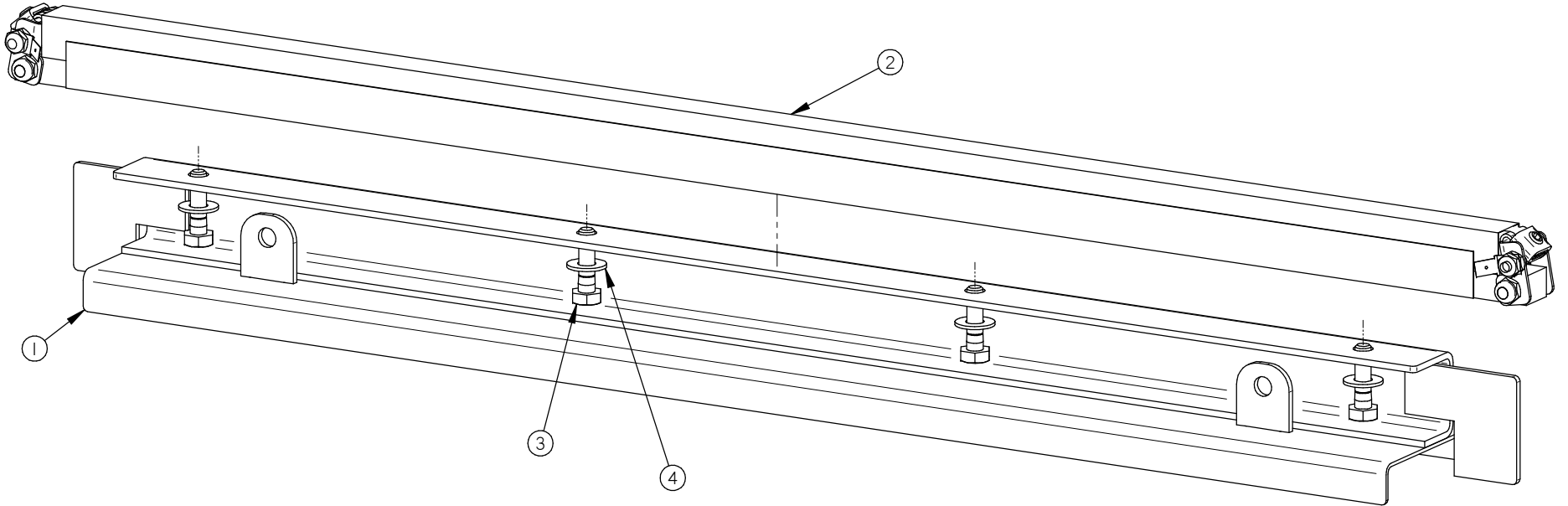

COSSE DE CE CÔTÉ
CONNECTOR ON THIS SIDE

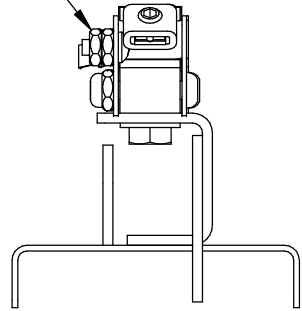

OPTION - TWIN SEAL / STAINLESS BAR

MACHINE		DEPT. TOL. METRIC		INCH		SIPROMAC	
600A & 620A		USINAGE	± 0.1	± 0.004"	ST-GERMAIN DE GRANTHAM QUEBEC CANADA		
PART		TOLERIE	± 0.5	± 0.020"			
SEAL BAR ASSY W/ SS SUPPORT (TWIN SEAL)		SOUDAGE	± 0.5	± 0.020"			
ITEM		CNC	N.T.S.		DEPT.	M	QTY. 4
MAT.		3D DWG BY SBU	DATE 14-10-09	NO. 005A1536			
		2D DWG BY SBU	DATE 14-10-09				

LET.	MODIFICATION	DATE	INT.
------	--------------	------	------

004A1125

ITEM	PART #	DESCRIPTION	QT.
1	002A2124	UPPER SEAL BAR SUPPORT	1
2	008-0402	UPPER SEAL BAR RUBBER	1
3	171-0180	TAPE CLEAR SUPER BOND 3/4" (0.024)	2
4	176-0200	TEFLON TAPE,PRESS.SENSITIVE 2" 683mm (0.08)	1

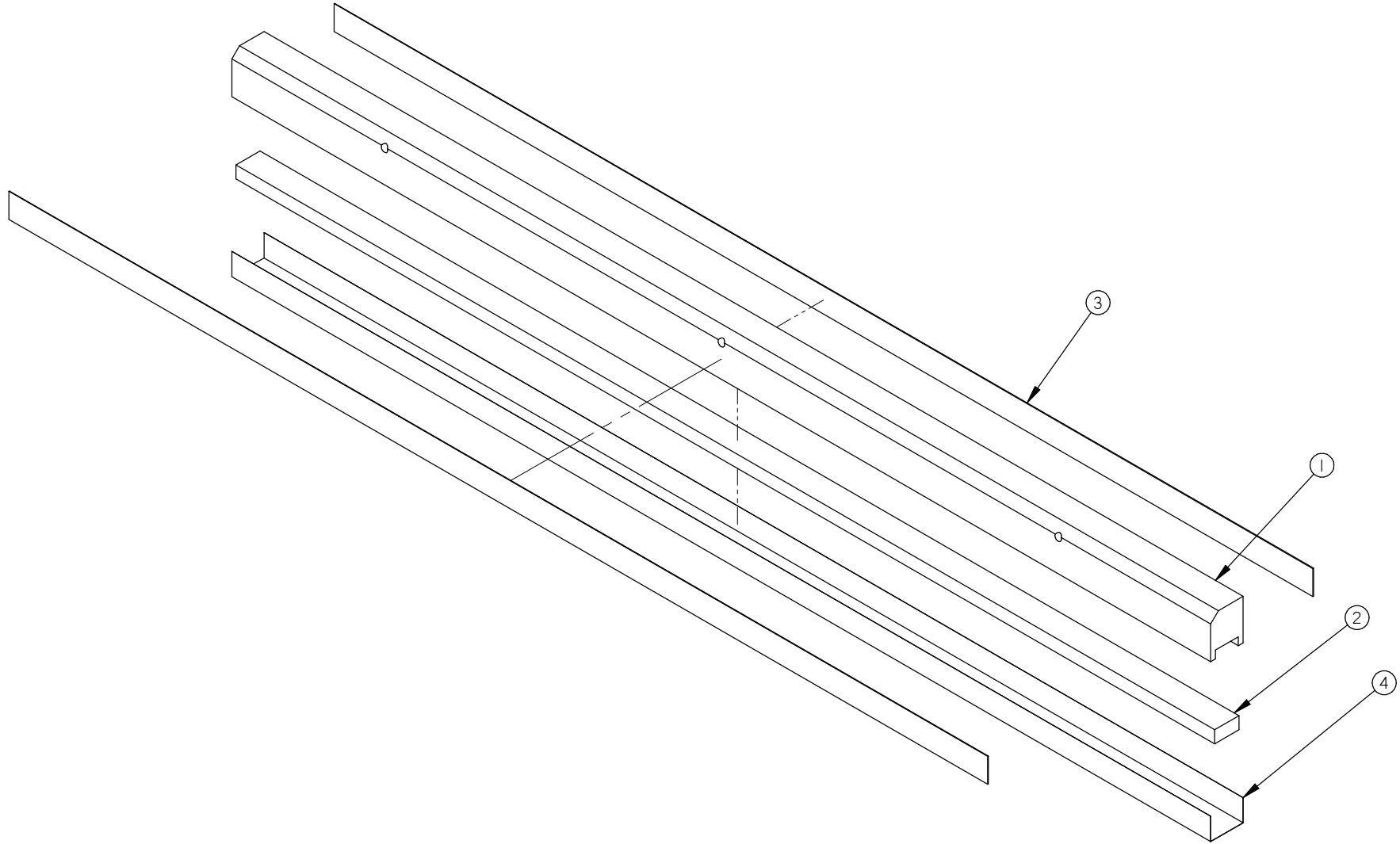

-TWIN SEAL-

D	600A ADDED	14-05-27	SBU
C	AJOUTER ITEM # 3 ET 4	14-03-31	S.L.
B	MODIF. #A-0444 / AJOUTER TWIN / ÉTAIT 005A0572	10-10-01	J.G.
A	REDESSINE VOIR AUSSI 004A2559 & 004A2560	08-04-30	J.G.
LET.	MODIFICATION	DATE	INT.

MACHINE	600A & 620A		DEPT. TOL. METRIC	INCH	SIPROMAC ST-GERMAIN DE GRANTHAM QUEBEC CANADA
PART	UPPER SEAL BAR ASSEMBLY (E.C.O.) & (TWIN)		USINAGE ± 0.1	± 0.004"	
ITEM	CNC	DEPT.	TOLERIE ± 0.5	± 0.020"	
MAT.	DWG BY J.G.	DATE 08-04-30	SOUDAGE ± 0.5	± 0.020"	N.T.S.
APP. BY		DATE	NO. 004A1125		M-I
					QTY. 2

004B1471

ITEM	PART #	DESCRIPTION	QT.	ITEM	PART #	DESCRIPTION	QT.
9	105-0258	EAR CLAMP 2" S/S	2	1	001B6563	PUMP SUPPORT	2
10	104-0125	HOSE 1-1/2" ID VACUUM POLYWIRE (1720mm)	1	2	004A0863	VACUUM/ATMOSPHERE VALVE ASSY	1
11	105-0250	EAR CLAMP 1-1/2" S/S	1	3	104-0150	HOSE 2" ID VACUUM POLYWIRE (554mm)	1
12	105-0110	SCREW CLAMPS 1-1/16" TO 2" ALL S/S	1	4	051-0783	WASHER 3/8" FLAT THICK S/S	20
13	125-0080	BUSCH RA-0255 230-460V/3PH/60HZ	1	5	051-0360	BOLT 3/8"-16nc. X 1" S/S	10
14	004A4082	BELLOWS ELBOW CONNECTOR ASSY	1	6	051-0622	NUT 3/8"-16nc. NYLON LOCK S/S	10
15	100-1250	STRAIGHT 2"MNPT X 2" HOSE BARB SS	1	7	051-0780	WASHER 3/8" FLAT S/S	4
16	125-0085	BUSCH RA-0255 575V/3PH/60HZ	1	8	051-09931	BOLT M10 X 20MM HEX SS	4

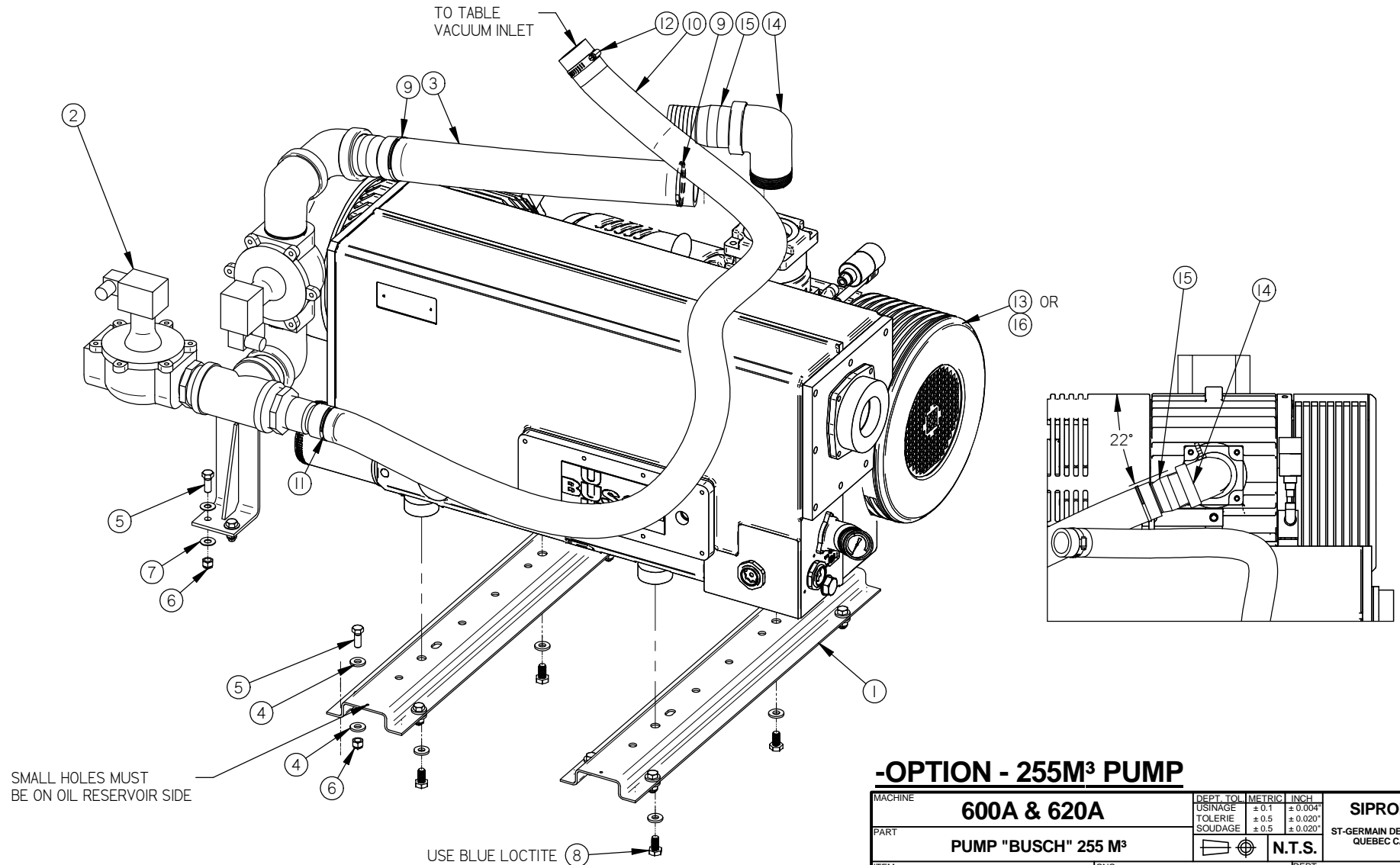

-OPTION - 255M³ PUMP

MACHINE	600A & 620A		DEPT. TOL.	METRIC	INCH	SIPROMAC ST-GERMAIN DE GRANTHAM QUEBEC CANADA
PART	PUMP "BUSCH" 255 M³		USINAGE	± 0.1	± 0.004"	
ITEM	CNC	DEPT.	TOLERIE	± 0.5	± 0.020"	
MAT.	APP. BY	DATE	SOUDEGE	± 0.5	± 0.020"	N.T.S.
DWG BY SBU		DATE 13-09-18	NO.		004B1471	QTY. 1

A	001B6563 WAS 001A6563	14-05-28	SBU
LET.	MODIFICATION	DATE	INT.

004B1469

ITEM	PART #	DESCRIPTION	QT.	ITEM	PART #	DESCRIPTION	QT.
9	051-09931	BOLT M10 X 20MM HEX SS	4	1	001B6563	PUMP SUPPORT	2
10	051-0360	BOLT 3/8"-16nc. X 1" S/S	10	2	004A0863	VACUUM/ATMOSPHERE VALVE ASSY	1
11	051-0622	NUT 3/8"-16nc. NYLON LOCK S/S	10	3	104-0125	HOSE 1-1/2" ID VACUUM POLYWIRE (1720mm)	1
12	051-0780	WASHER 3/8" FLAT S/S	4	4	105-0110	SCREW CLAMPS 1-1/16" TO 2" ALL S/S	1
13	125-0070	BUSCH RA-0165 230-460V/3PH/60HZ	1	5	105-0250	EAR CLAMP 1-1/2" S/S	1
14	004A4082	BELLOWS ELBOW CONNECTOR ASSY	1	6	104-0150	HOSE 2" ID VACUUM POLYWIRE (570mm)	1
15	100-1250	STRAIGHT 2"MNPT X 2" HOSE BARB SS	1	7	105-0258	EAR CLAMP 2" S/S	2
16	125-0075	BUSCH RA-0165 575V/3PH/60HZ	1	8	051-0783	WASHER 3/8" FLAT THICK S/S	20

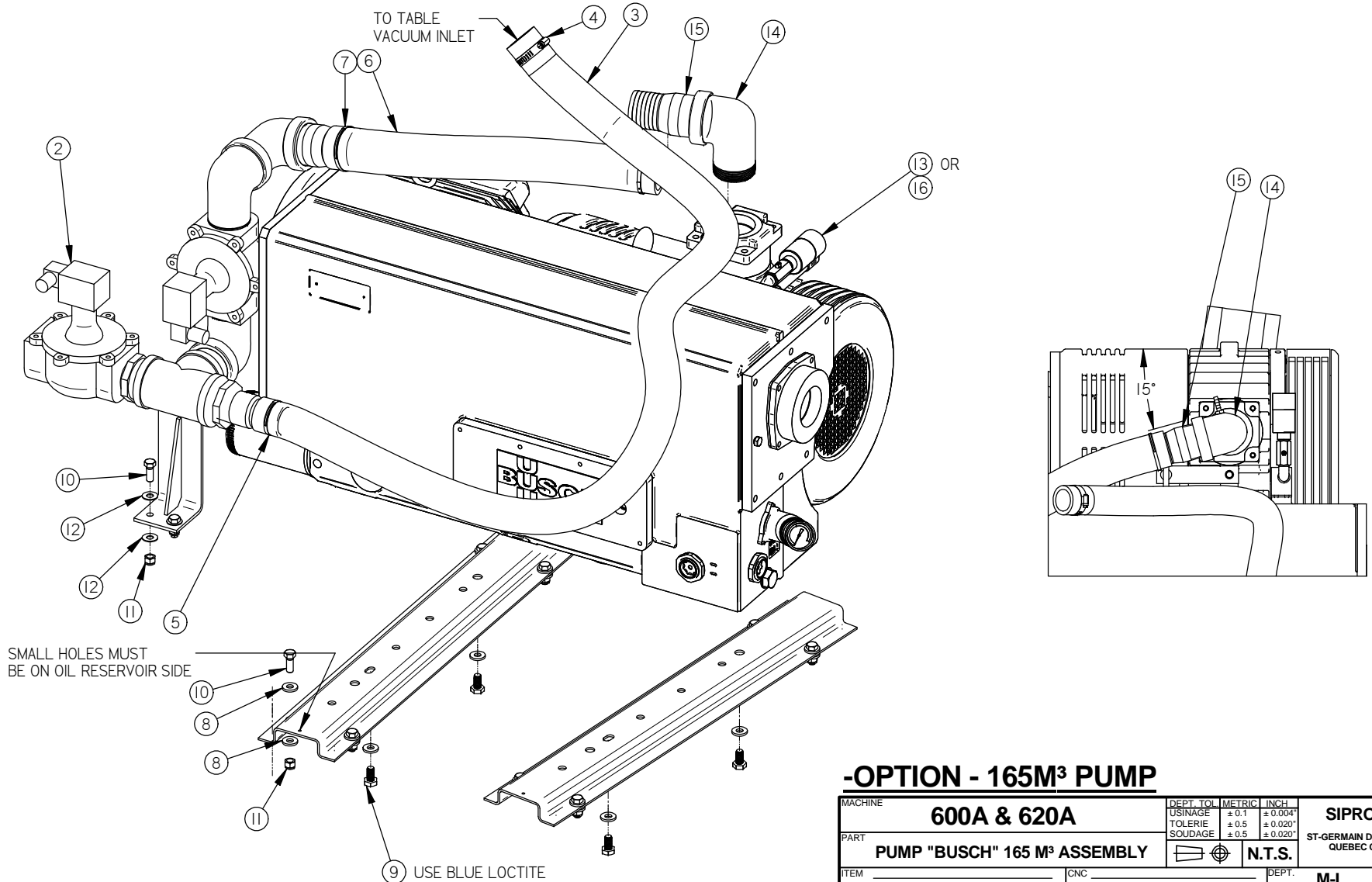

-OPTION - 165M³ PUMP

MACHINE		DEPT. TOL. METRIC		INCH		SIPROMAC	
600A & 620A		USINAGE	± 0.1	± 0.004"	ST-GERMAIN DE GRANTHAM		
PART		TOLERIE	± 0.5	± 0.020"	QUEBEC CANADA		
PUMP "BUSCH" 165 M ³ ASSEMBLY		SOUDAGE	± 0.5	± 0.020"	N.T.S.		
ITEM	CNC	DEPT.	M-I		QTY.	1	
MAT.	DWG BY SBU	DATE	13-09-18		NO. 004B1469		
	APP. BY	DATE					

A	001B6563 WAS 001A6563	14-05-28	SBU
LET.	MODIFICATION	DATE	INT.

004B1468

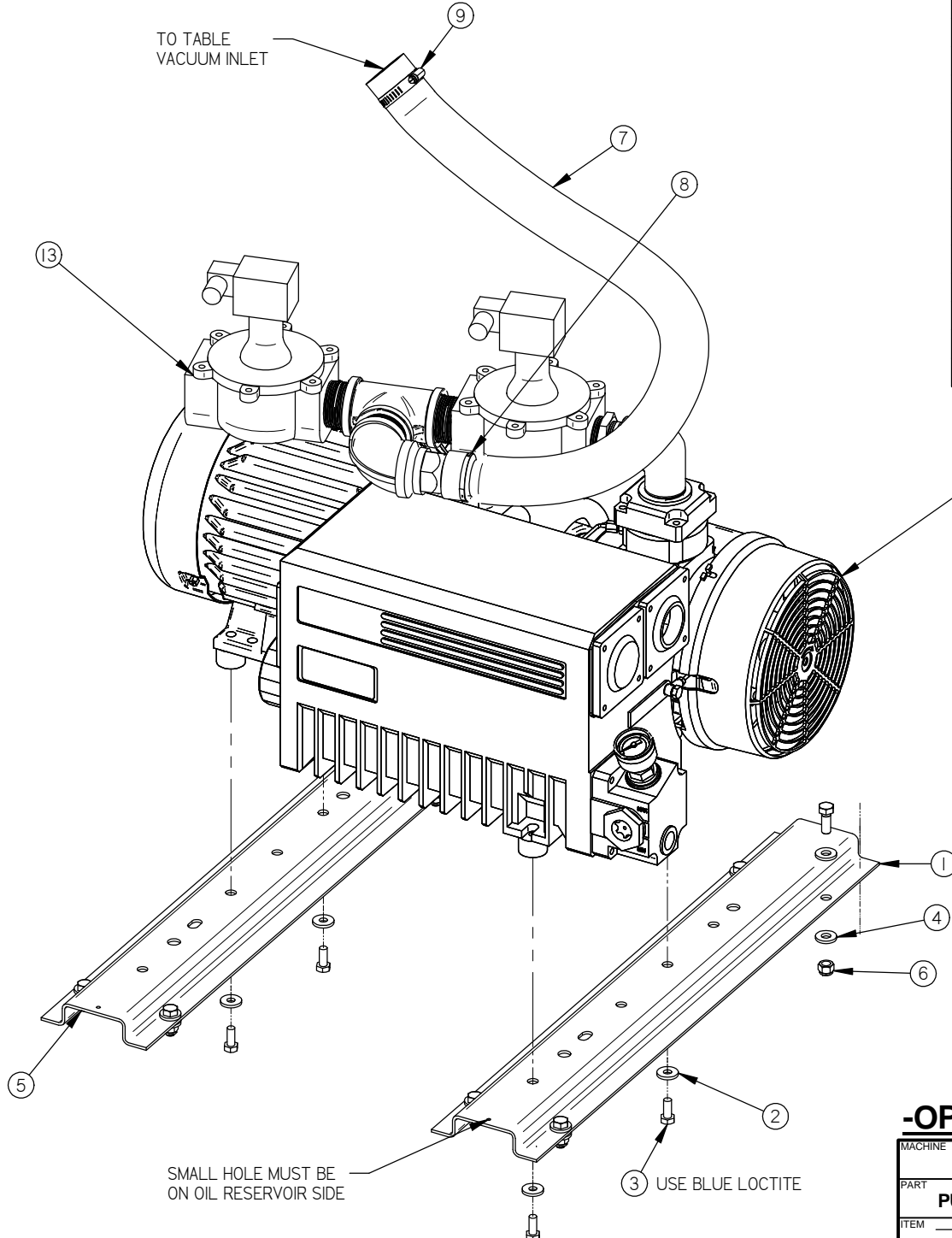

ITEM	PART #	DESCRIPTION	QT.
1	001B6563	PUMP SUPPORT	2
2	051-0762	WASHER 5/16" THICK FLAT S/S	4
3	051-0980	BOLT M8 x 20 S/S	4
4	051-0783	WASHER 3/8" FLAT THICK S/S	16
5	051-0360	BOLT 3/8"-16nc. X 1" S/S	8
6	051-0622	NUT 3/8"-16nc. NYLON LOCK S/S	8
7	104-0125	HOSE 1-1/2" ID VACUUM POLYWIRE (810mm)	1
8	105-0250	EAR CLAMP 1-1/2" S/S	1
9	105-0110	SCREW CLAMPS 1-1/16" TO 2" ALL S/S	1
10	125-0060	BUSCH RA-0100 230-460V/3PH/60HZ	1
11	125-0062	BUSCH RA-0100 575V/3PH/60HZ	1
12	125-0064	BUSCH RA-0100 220V/1PH/60HZ	1
13	004B1404	VACUUM / ATMOSPHERE VALVE ASSY.	1

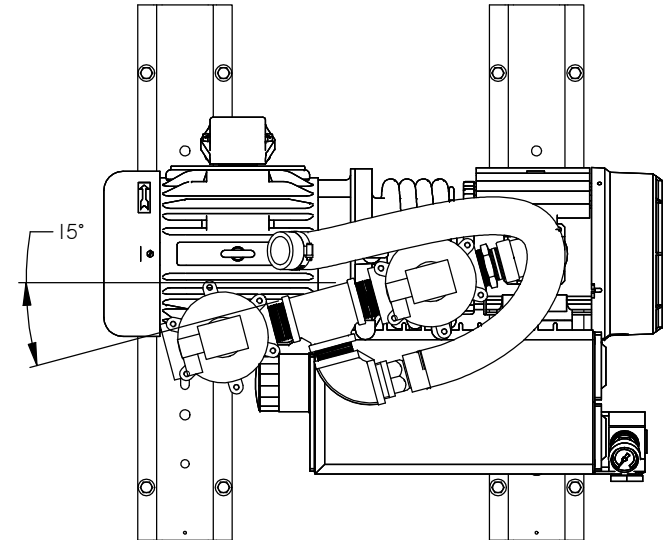

-OPTION - 100M³ PUMP

MACHINE		DEPT. TOL. METRIC		INCH		SIPROMAC	
600A & 620A		USINAGE ± 0.1		± 0.004"		ST-GERMAIN DE GRANTHAM	
PART		TOLERIE ± 0.5		± 0.020"		QUEBEC CANADA	
PUMP "BUSCH" 100 M³ ASSEMBLY		SOUDAGE ± 0.5		± 0.020"		N.T.S.	
ITEM	CNC	DEPT.	M-I	QTY.	1		
MAT.	DWG BY SBU	DATE 13-09-19	NO. 004B1468				
		APP. BY	DATE				

A	001B6563 WAS 001A6563	0	1
LET.	MODIFICATION	DATE	INT.

004A4141

ITEM	PART #	DESCRIPTION	QT.	ITEM	PART #	DESCRIPTION	QT.
9	105-0258	EAR CLAMP 2" S/S	2	1	001B6563	PUMP SUPPORT	2
10	104-0125	HOSE 1-1/2" ID VACUUM POLYWIRE (1720mm)	1	2	004A0863	VACUUM/ATMOSPHERE VALVE ASSY	1
11	105-0250	EAR CLAMP 1-1/2" S/S	1	3	104-0150	HOSE 2" ID VACUUM POLYWIRE (554mm)	1
12	105-0110	SCREW CLAMPS 1-1/16" TO 2" ALL S/S	1	4	051-0783	WASHER 3/8" FLAT THICK S/S	20
13	125-0087	BUSCH RA-0305 230-460V/3PH/60HZ	1	5	051-0360	BOLT 3/8"-16nc. X 1" S/S	10
14	004A4082	BELLOWS ELBOW CONNECTOR ASSY	1	6	051-0622	NUT 3/8"-16nc. NYLON LOCK S/S	10
15	100-1250	STRAIGHT 2"MNPT X 2" HOSE BARB SS	1	7	051-0780	WASHER 3/8" FLAT S/S	4
16	125-0088	BUSCH RA-0305 575V/3PH/60HZ	1	8	051-09931	BOLT M10 X 20MM HEX SS	4

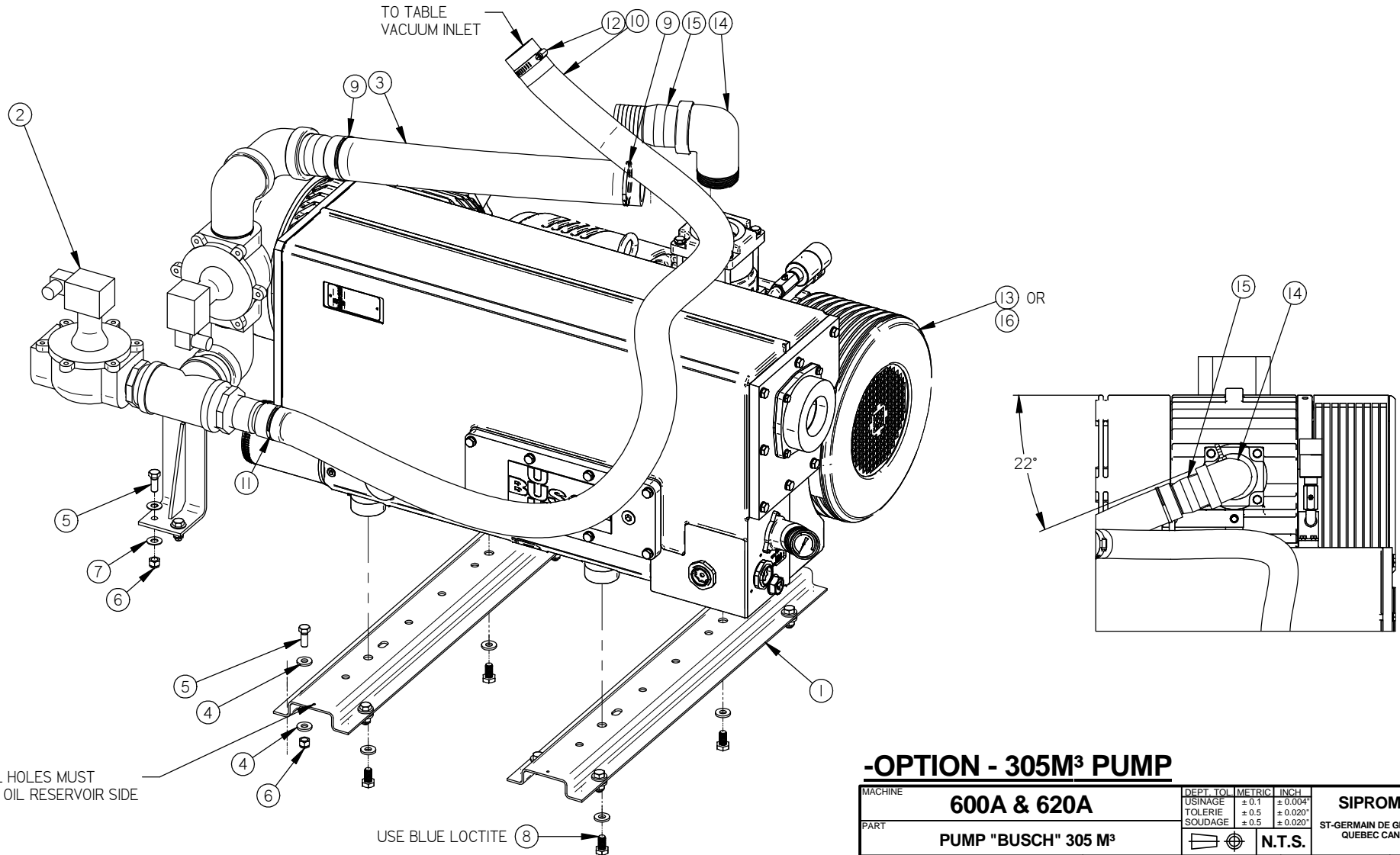

-OPTION - 305M³ PUMP

MACHINE	600A & 620A		DEPT. TOL. METRIC	INCH	SIPROMAC ST-GERMAIN DE GRANTHAM QUEBEC CANADA
PART	PUMP "BUSCH" 305 M³		USINAGE ± 0.1	± 0.004"	
ITEM	CNC	DATE	TOLERIE ± 0.5	± 0.020"	
MAT.	APP. BY	DATE	SOUDEGE ± 0.5	± 0.020"	N.T.S.
DWG BY SBU		DATE 13-11-21	DEPT. M-I		QTY. 1
					004A4141

A	001B6563 WAS 001A6563	14-05-28	SBU
LET.	MODIFICATION	DATE	INT.

004B1404

ITEM	PART #	DESCRIPTION	QT.
1	004A4081	BELLOWS ELBOW CONNECTOR ASSY	1
2	100-0245	CLOSE NIPPLE 1 1/4"npt. S/S	1
3	106-0050	VALVE 2WAY 24V 1-1/2"NPT(B60)60Hz	2
4	100-0485	TEE 1-1/2" NPT S/S	1
5	100-0440	NIPPLE 1-1/2" NPT X 2" SS	3
6	100-0047	ELBOW 90° X 1-1/2" NPT S/S	1
7	100-1230	STRAIGHT 1-1/2"MNPT x1-1/2" HOSE BARB	1
8	100-0555	RED.BUSH.1-1/2" x 1-1/4" NPT S/S	1

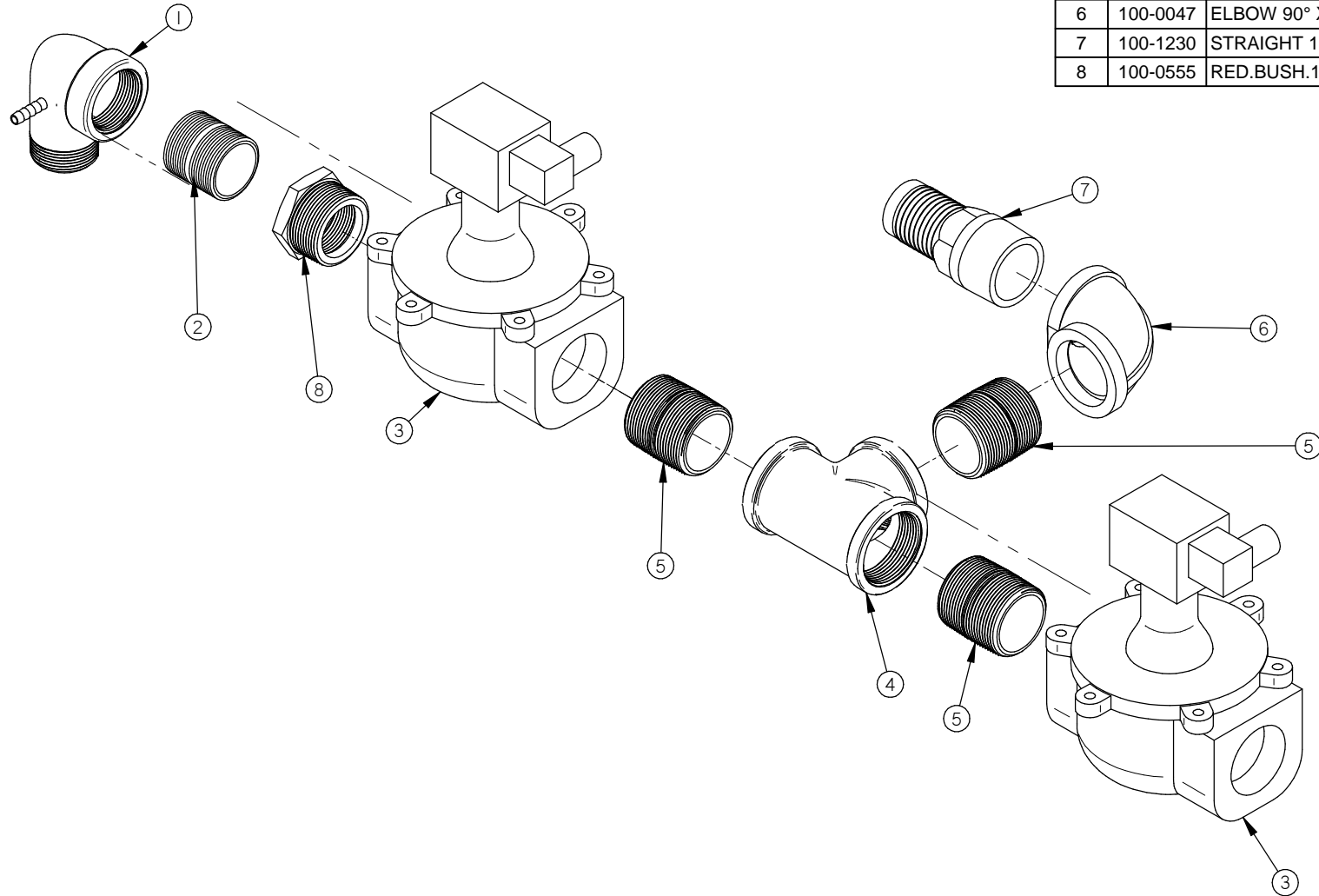

-OPTION - 40M³, 63M³ & 100M³ PUMP

MACHINE		DEPT. TOL. METRIC		INCH		SIPROMAC ST-GERMAIN DE GRANTHAM QUEBEC CANADA
VACUUM		USINAGE	± 0.1	± 0.004"		
PART		TOLERIE	± 0.5	± 0.020"		
VACUUM / ATMOSPHERE VALVE ASSY.		SOUDEAGE	± 0.5	± 0.020"		N.T.S.
ITEM	CNC	DEPT.	M-I	QTY.	1	
MAT.	DWG BY SBU	DATE 13-09-19	NO.	004B1404		
	APP. BY	DATE				

LET.	MODIFICATION	DATE	INT.
------	--------------	------	------

004A0863

ITEM	PART #	DESCRIPTION	QT.
1	106-0060	VALVE 2WAY 24V 2" NPT(B80) 60HZ	1
2	100-1250	STRAIGHT 2"MNPT X 2" HOSE BARB SS	1
3	100-0250	CLOSE NIPPLE 2" NPT SS	1
4	004B1621	VAC./ATM. VALVE SUPP. PRE-ASS'Y	1
5	106-0050	VALVE 2WAY 24V 1-1/2"NPT(B60)60Hz	1
6	100-0095	STREET ELBOW 90° X 2" NPT SS	3
7	100-0561	RED.BUSH. 2"NPTx1-1/2"NPT SS	2
8	100-0250	CLOSE NIPPLE 1-1/2"NPT S/S	1
9	100-0740	STR.1-1/2"MNPTx1-1/2"HOSE SS	1

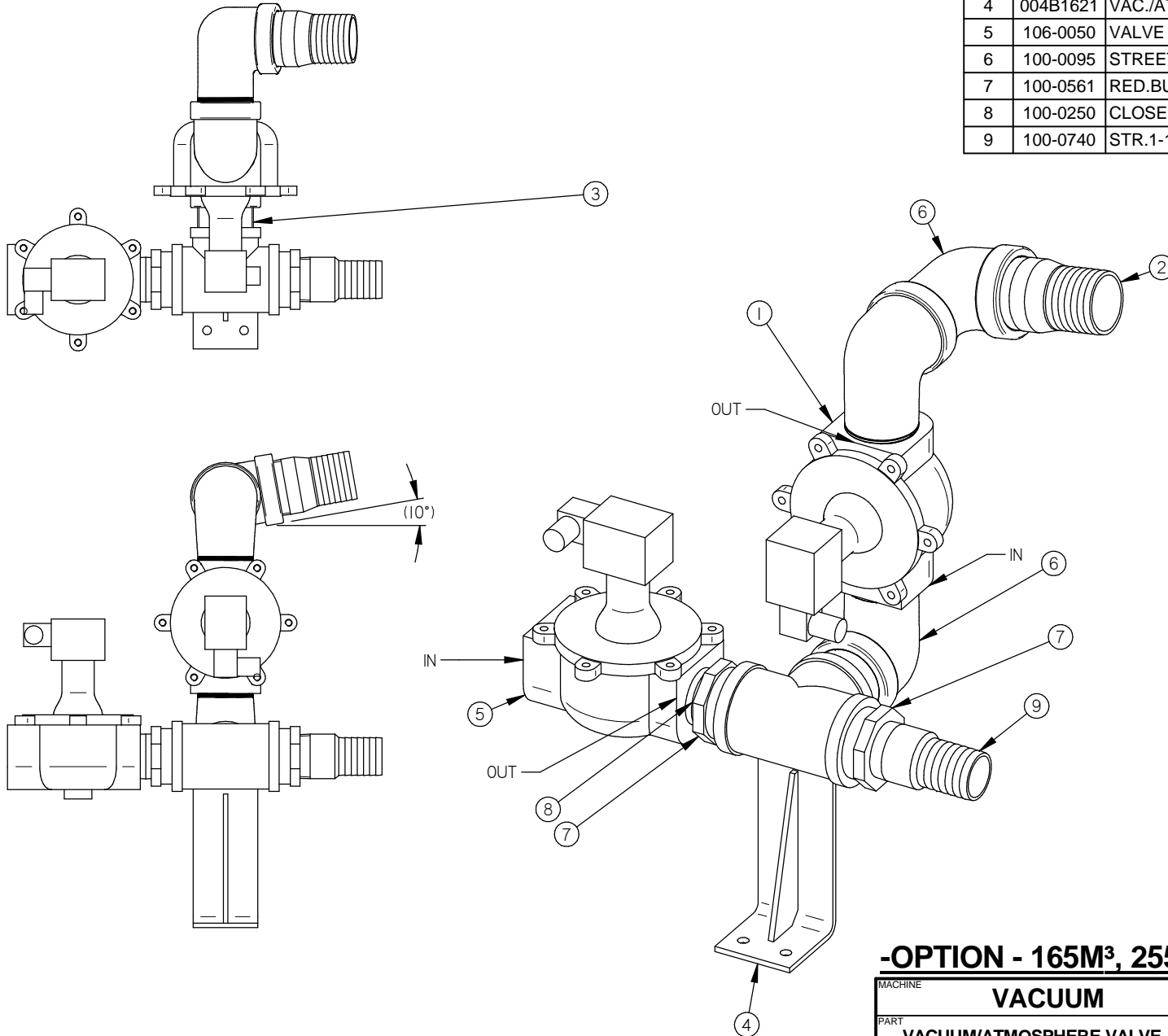

-OPTION - 165M³, 255M³ & 305M³ PUMP

MACHINE		DEPT. TOL. METRIC		INCH		SIPROMAC	
VACUUM		USINAGE	± 0.1	± 0.004"	ST-GERMAIN DE GRANTHAM		
PART		TOLERIE	± 0.5	± 0.020"	QUEBEC CANADA		
VACUUM/ATMOSPHERE VALVE ASSY		SOUDEAGE	± 0.5	± 0.020"	N.T.S.		
ITEM	CNC	DEPT.	M	QTY.	1		
MAT.	DWG BY SBU	DATE 13-09-18	NO.		004A0863		
	APP. BY	DATE					

LET.	MODIFICATION	DATE	INT.
------	--------------	------	------

004A4111

ITEM	PART #	DESCRIPTION	QT.
1	100-0555	RED.BUSH.1-1/2" x 1-1/4" NPT S/S	1
2	100-0245	CLOSE NIPPLE 1/4"npt. S/S	1
3	107-0090	BALL VALVE 1-1/4"NPT	1
4	114-2030	VACUUM MUFFLER 1-1/4"NPT	1

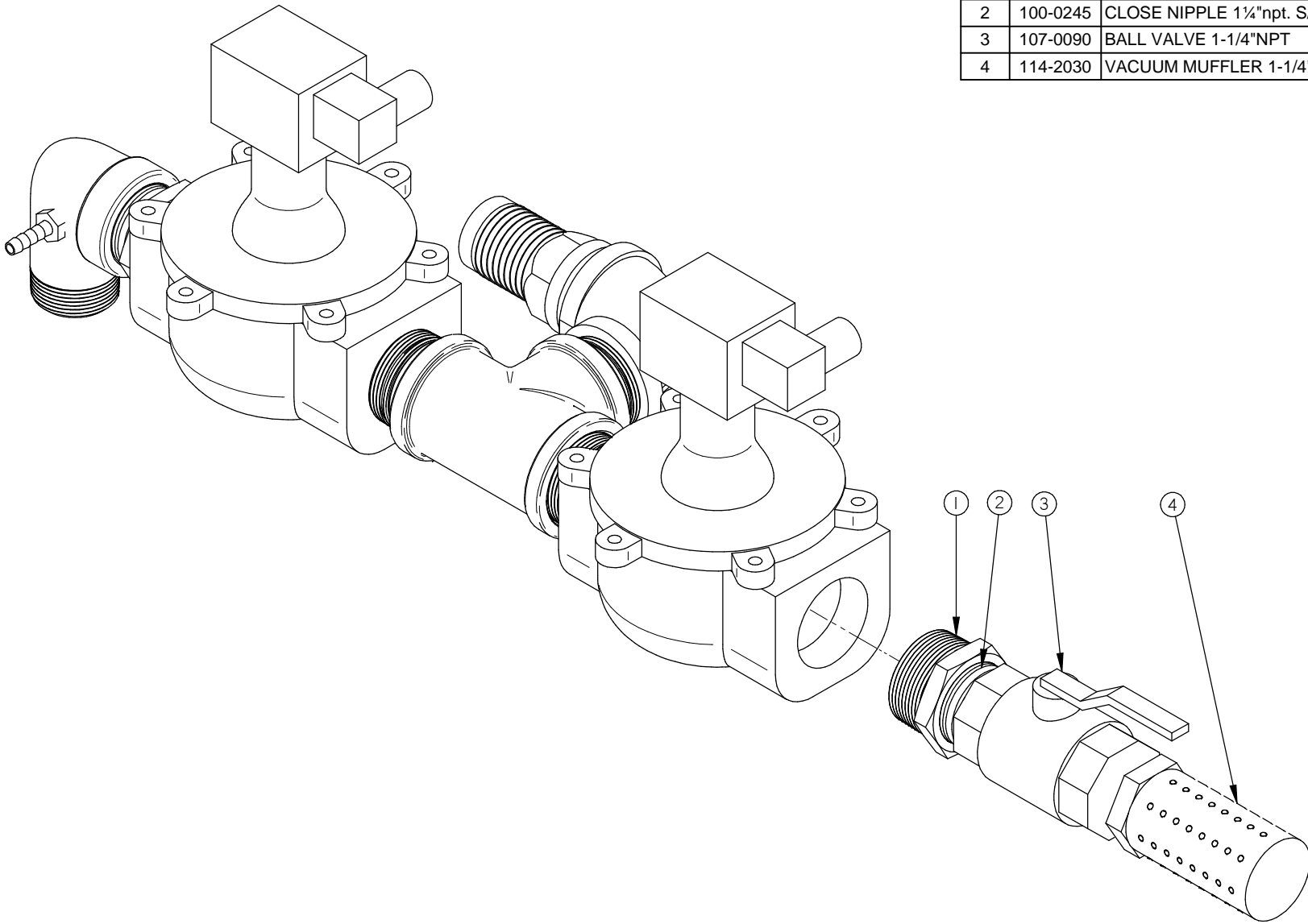

-OPTION - SOFT AIR + MUFFLER 40M³ @ 100M³

LET.	MODIFICATION	DATE	INT.
------	--------------	------	------

MACHINE		VACUUM		DEPT. TOL.	METRIC	INCH	SIPROMAC ST-GERMAIN DE GRANTHAM QUEBEC CANADA
PART		VACUUM/ATMOSPHERE VALVE (OPT SOFT AIR+MUFFLER)		USINAGE	± 0.1	± 0.004"	
ITEM		CNC		TOLERIE	± 0.5	± 0.020"	
MAT.		APP. BY		SOUDEAGE		± 0.5	± 0.020"
		DWG BY SBU		DATE 13-09-19		N.T.S.	
		APP. BY		DATE		DEPT. M QTY. 1	
						004A4111	

004A4110

ITEM	PART #	DESCRIPTION	QT.
1	100-0555	RED.BUSH.1-1/2" x 1-1/4" NPT S/S	1
2	100-0245	CLOSE NIPPLE 1 1/4"npt. S/S	1
3	107-0090	BALL VALVE 1-1/4"NPT	1

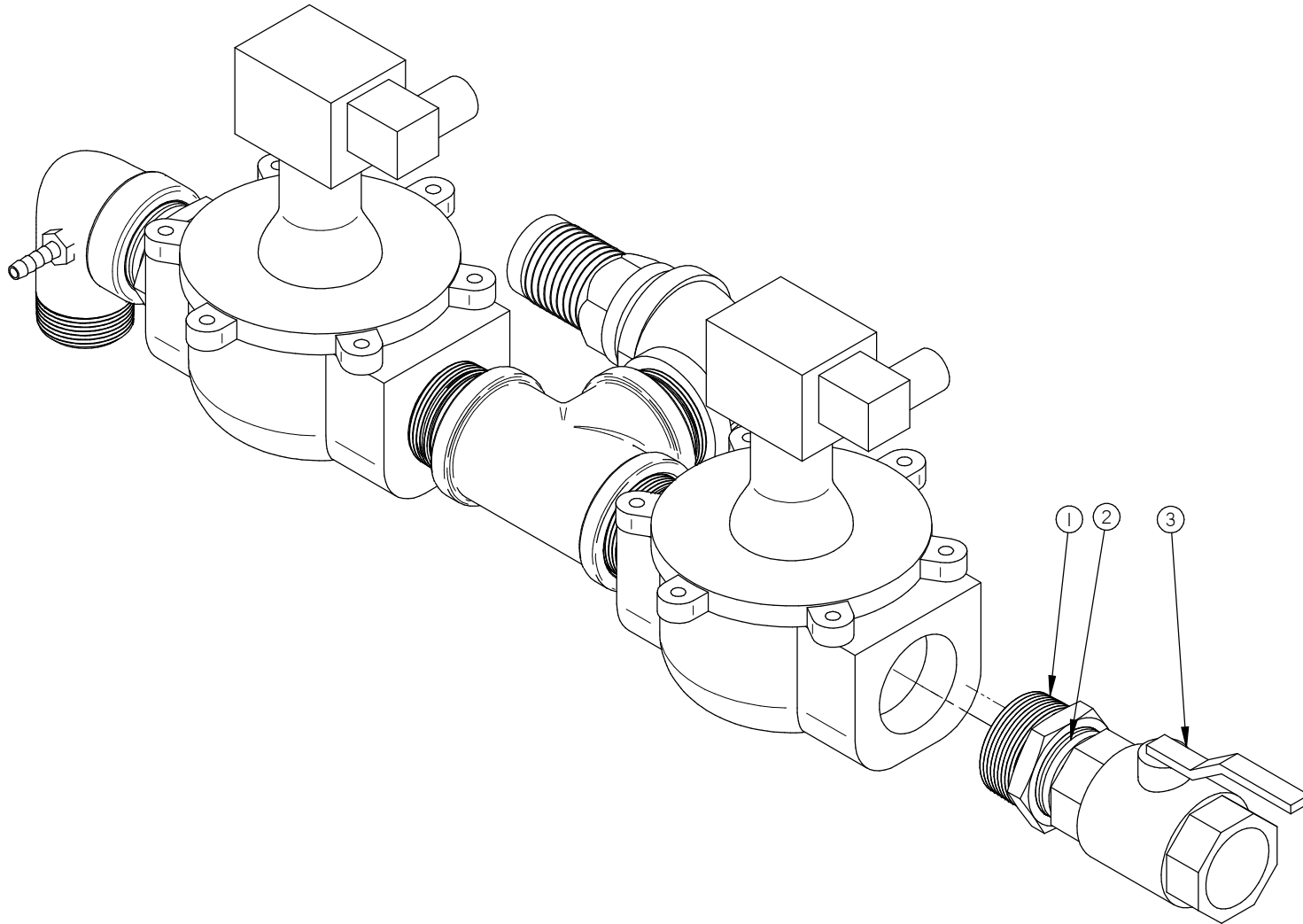

-OPTION - SOFT AIR 40M³ @ 100M³

MACHINE		VACUUM		DEPT. TOL.	METRIC	INCH	SIPROMAC ST-GERMAIN DE GRANTHAM QUEBEC CANADA
PART		VACUUM/ATMOSPHERE VALVE (OPT SOFT AIR)		USINAGE	± 0.1	± 0.004"	
ITEM		CNC		TOLERIE	± 0.5	± 0.020"	
MAT.		APP. BY		SBU		DATE	13-09-19
DATE		MODIFICATION		DATE		INT.	N.T.S.
NO.		M		QTY.		1	
NO.		004A4110					

LET.	MODIFICATION	DATE	INT.
------	--------------	------	------

004A4109

ITEM	PART #	DESCRIPTION	QT.
1	100-0555	RED.BUSH.1-1/2" x 1-1/4" NPT S/S	1
2	114-2030	VACUUM MUFFLER 1-1/4"NPT	1

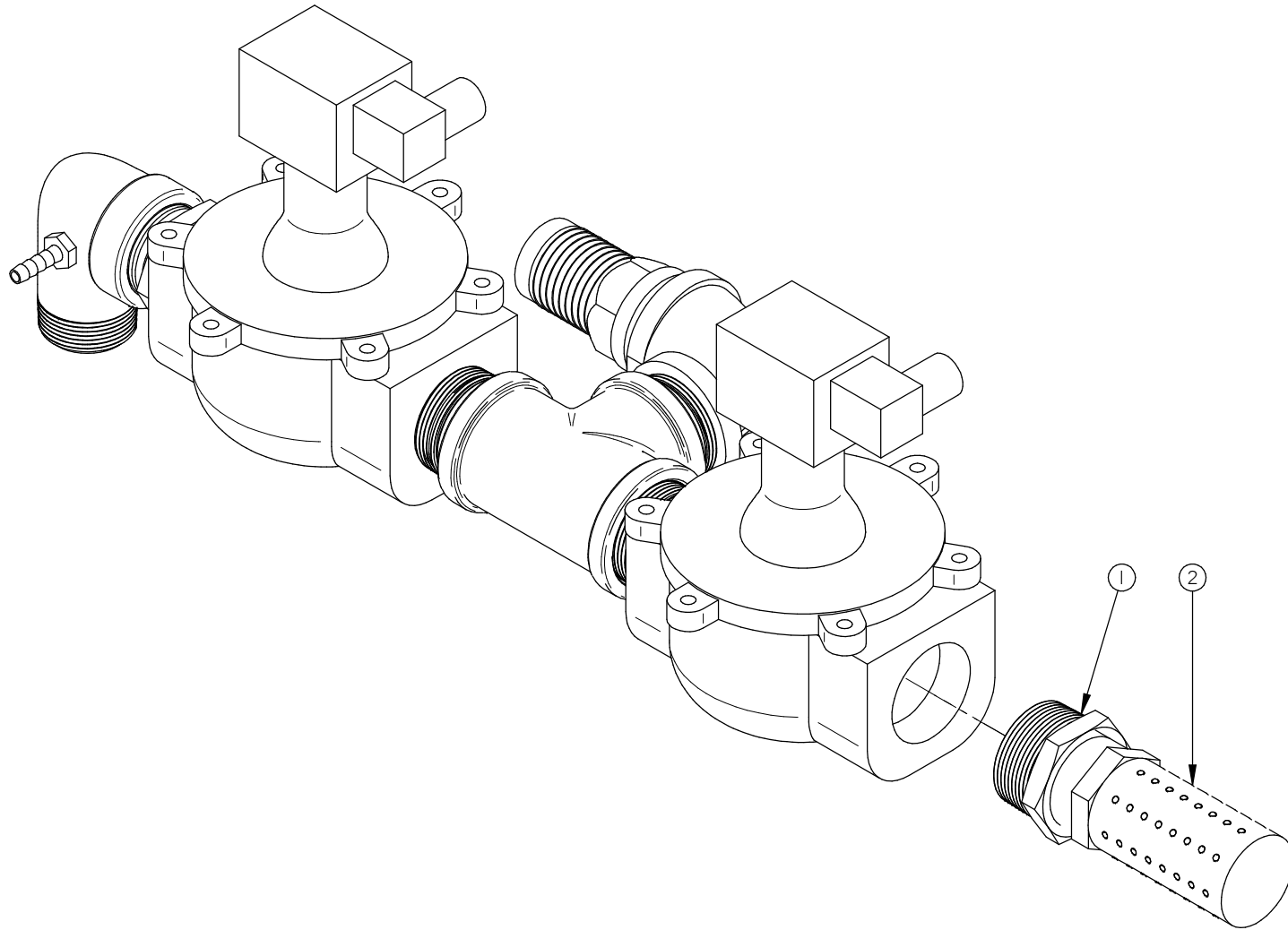

-OPTION - MUFFLER 40M³ @ 100M³

MACHINE		VACUUM		DEPT. TOL.	METRIC	INCH	SIPROMAC ST-GERMAIN DE GRANTHAM QUEBEC CANADA
PART		VACUUM/ATMOSPHERE VALVE (OPT MUFFLER)		USINAGE	± 0.1	± 0.004"	
ITEM		CNC		TOLERIE	± 0.5	± 0.020"	
MAT.		APP. BY		SBU		DATE	13-09-19
DATE		INT.		N.T.S.		DEPT.	M
MODIFICATION		DATE		NO.		QTY.	1
						004A4109	

LET.	MODIFICATION	DATE	INT.
------	--------------	------	------

004A4108

ITEM	PART #	DESCRIPTION	QT.
2	100-0555	RED.BUSH.1-1/2" x 1-1/4" NPT S/S	1
3	100-0090	STREET ELBOW 90° X 1-1/4" NPT SS	2
4	100-0245	CLOSE NIPPLE 1 1/4"npt. S/S	1
5	107-0090	BALL VALVE 1-1/4"NPT	1
6	114-2030	VACUUM MUFFLER 1-1/4"NPT	1

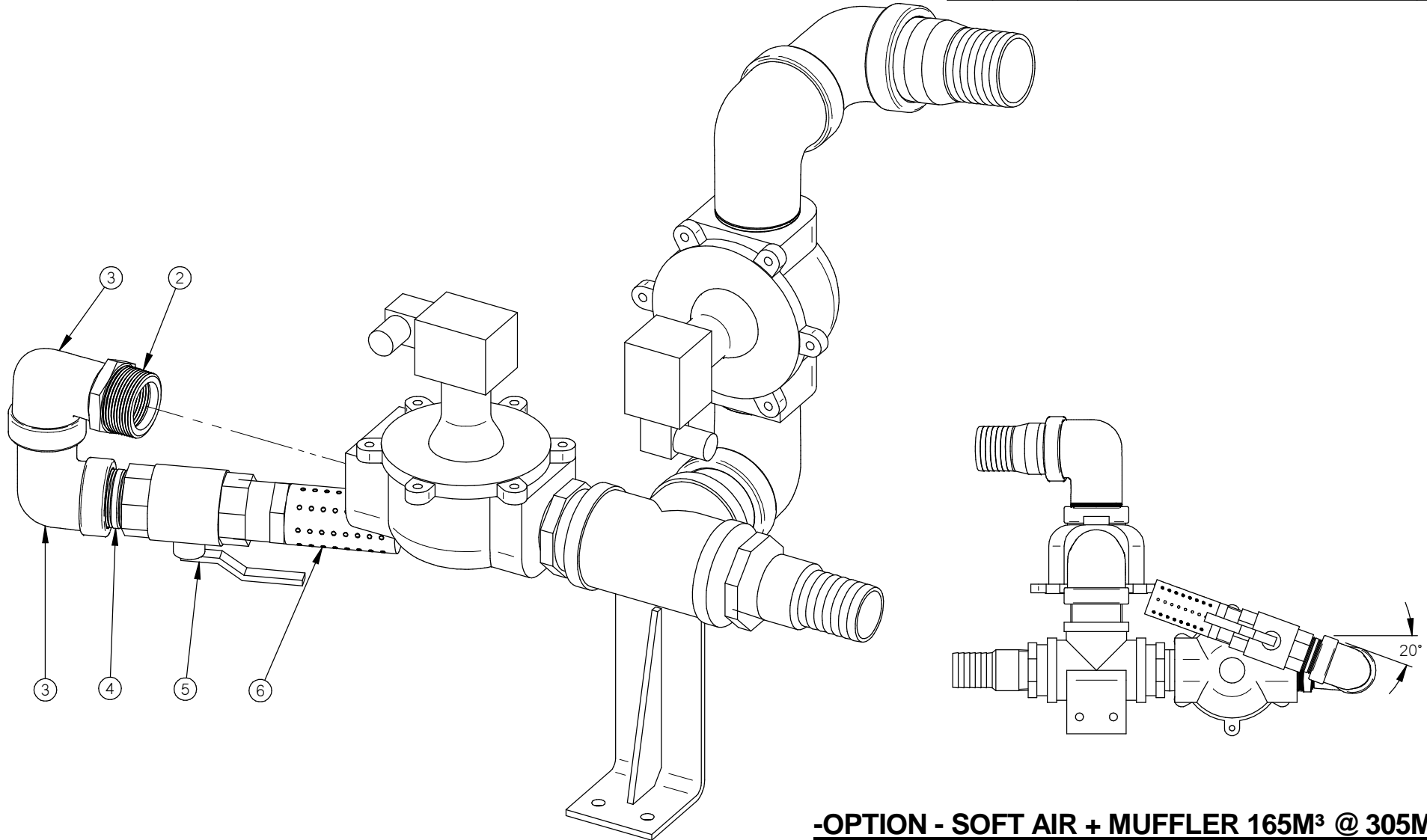

-OPTION - SOFT AIR + MUFFLER 165M³ @ 305M³

MACHINE		DEPT. TOL. METRIC		INCH		SIPROMAC	
600A & 620A		USINAGE	± 0.1	± 0.004"	ST-GERMAIN DE GRANTHAM QUEBEC CANADA		
PART		TOLERIE	± 0.5	± 0.020"			
VACUUM/ATMOSPHERE VALVE (OPT SOFT AIR + MUFFLER)		SOUDAGE	± 0.5	± 0.020"			
ITEM		CNC		DEPT.		M	
MAT.		DWG BY SBU		DATE 13-09-18		NO. 004A4108	
		APP. BY		DATE		QTY. 1	

LET.	MODIFICATION	DATE	INT.
------	--------------	------	------

004A4107

ITEM	PART #	DESCRIPTION	QT.
2	100-0555	RED.BUSH.1-1/2" x 1-1/4" NPT S/S	1
3	100-0090	STREET ELBOW 90° X 1-1/4" NPT SS	2
4	100-0245	CLOSE NIPPLE 1 1/4"npt. S/S	1
5	107-0090	BALL VALVE 1-1/4"NPT	1

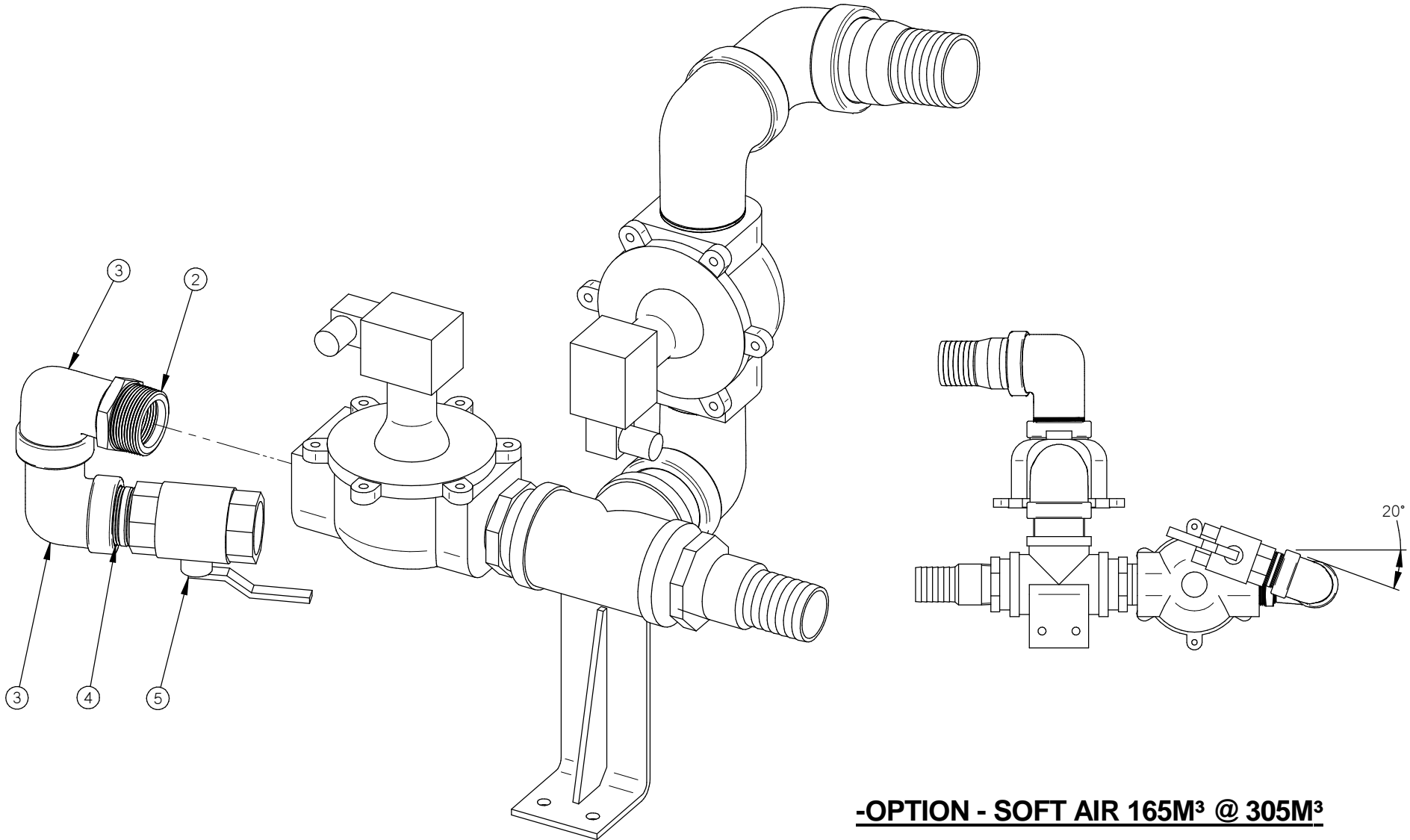

-OPTION - SOFT AIR 165M³ @ 305M³

MACHINE		DEPT.	TOL.	METRIC	INCH	SIPROMAC ST-GERMAIN DE GRANTHAM QUEBEC CANADA
600A & 620A			USINAGE	± 0.1	± 0.004"	
PART			TOLERIE	± 0.5	± 0.020"	
VACUUM/ATMOSPHERE VALVE (OPT SOFT AIR)			SOUDAGE	± 0.5	± 0.020"	N.T.S.
ITEM	CNC	DEPT.	M	QTY.	1	
MAT.	DWG BY	DATE	NO.	004A4107		
	APP. BY	DATE				

LET.	MODIFICATION	DATE	INT.
------	--------------	------	------

004A4106

ITEM	PART #	DESCRIPTION	QT.
2	100-0555	RED.BUSH.1-1/2" x 1-1/4" NPT S/S	1
3	100-0090	STREET ELBOW 90° X 1-1/4" NPT SS	2
4	114-2030	VACUUM MUFFLER 1-1/4"NPT	1

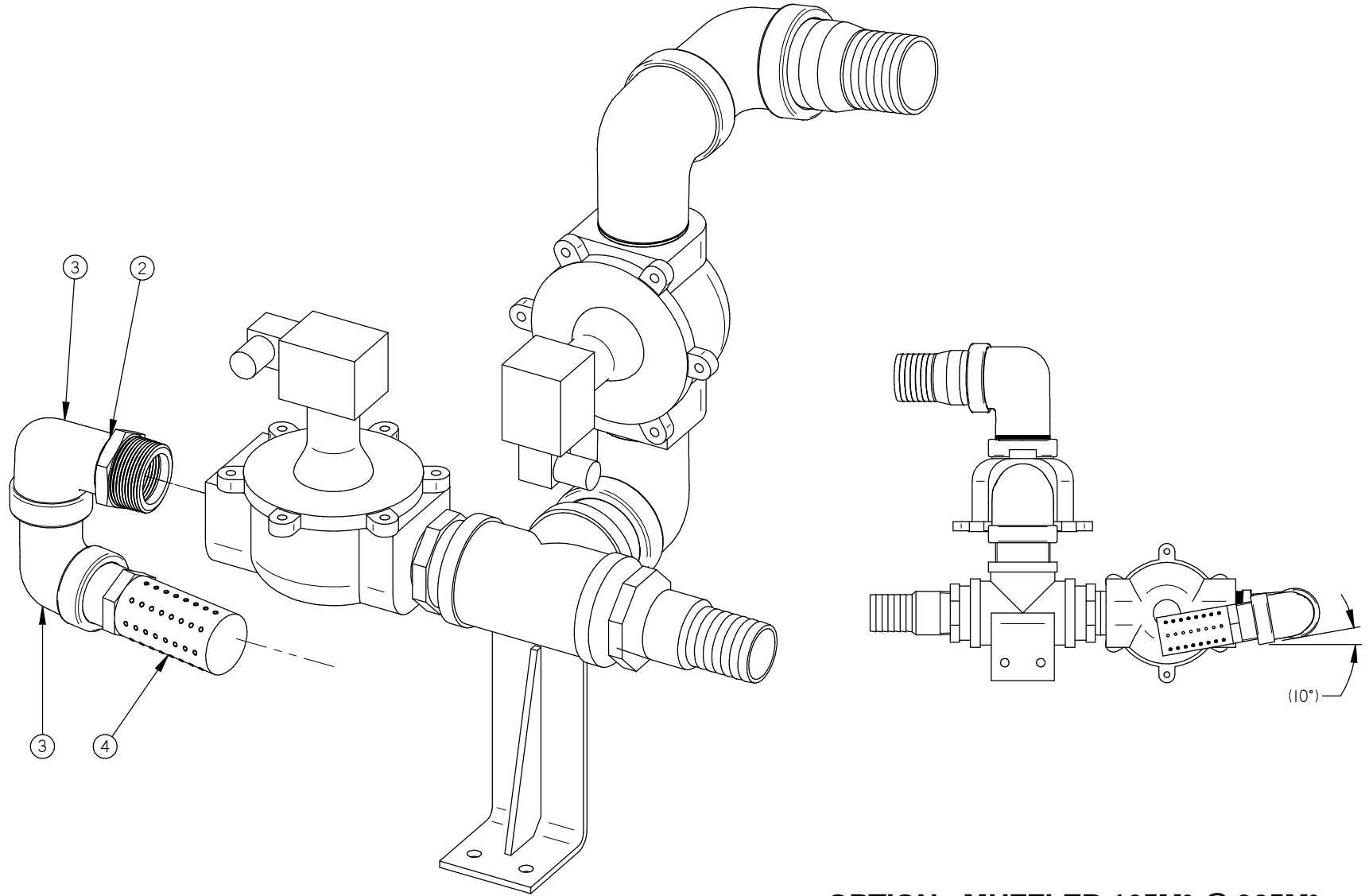

-OPTION - MUFFLER 165M³ @ 305M³

MACHINE		DEPT. TOL. METRIC		INCH		SIPROMAC ST-GERMAIN DE GRANTHAM QUEBEC CANADA
600A & 620A		USINAGE	± 0.1	± 0.004"		
PART		TOLERIE	± 0.5	± 0.020"		
VACUUM/ATMOSPHERE VALVE (OPT MUFFLER)		SOUDEGE	± 0.5	± 0.020"		N.T.S.
ITEM	CNC	DEPT.	M	QTY.	1	
MAT.	DWG BY SBU	DATE 13-09-18	NO.	004A4106		
	APP. BY	DATE				

LET.	MODIFICATION	DATE	INT.
------	--------------	------	------

004B4113

ITEM	PART #	DESCRIPTION	QT.
1	106-0010	VALVE 2WAY N.C. 24VAC 1/4" NPT(SMC)	1
2	102-0330	ELBOW 1/4" NPT X 3/8" HOSE QUICK	1
3	100-0065	STREET ELBOW 1/4" NPT SS	1
4	102-0361	Y BRANCH 1/4" MNPT X 3/8" T. QUICK	1

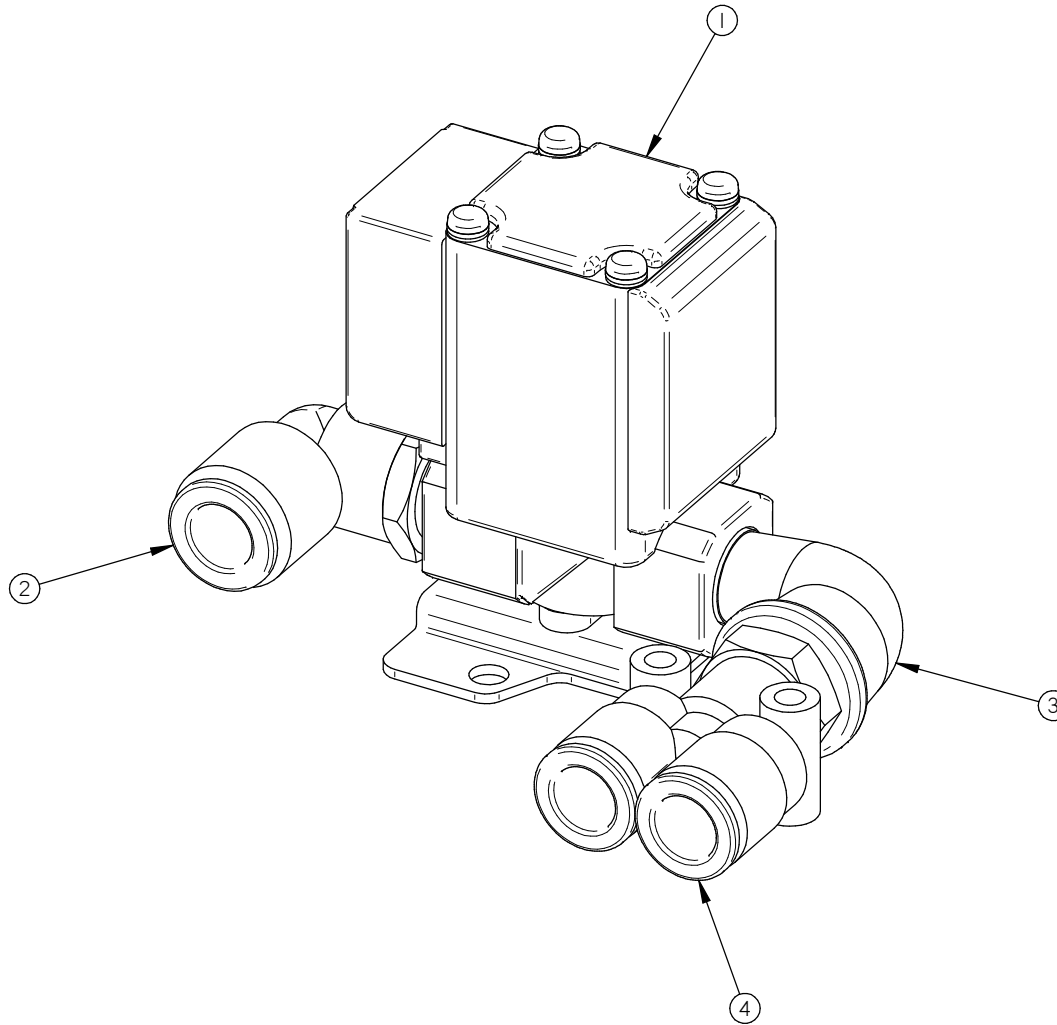

-OPTION - GAS

MACHINE		VACUUM		DEPT. TOL.	METRIC	INCH	SIPROMAC ST-GERMAIN DE GRANTHAM QUEBEC CANADA
PART		GAS VALVE ASSEMBLY (OPTION)		USINAGE	± 0.1	± 0.004"	
ITEM				TOLERIE	± 0.5	± 0.020"	
MAT.				SOUDEAGE	± 0.5	± 0.020"	N.T.S.
APP. BY		SBU		DATE	14-05-27		NO. 004B4113
LET.		MODIFICATION		DATE	INT.		DEPT. M QTY. 2

A	VALVE UPDATE	14-05-27	SBU
LET.	MODIFICATION	DATE	INT.

004B4104

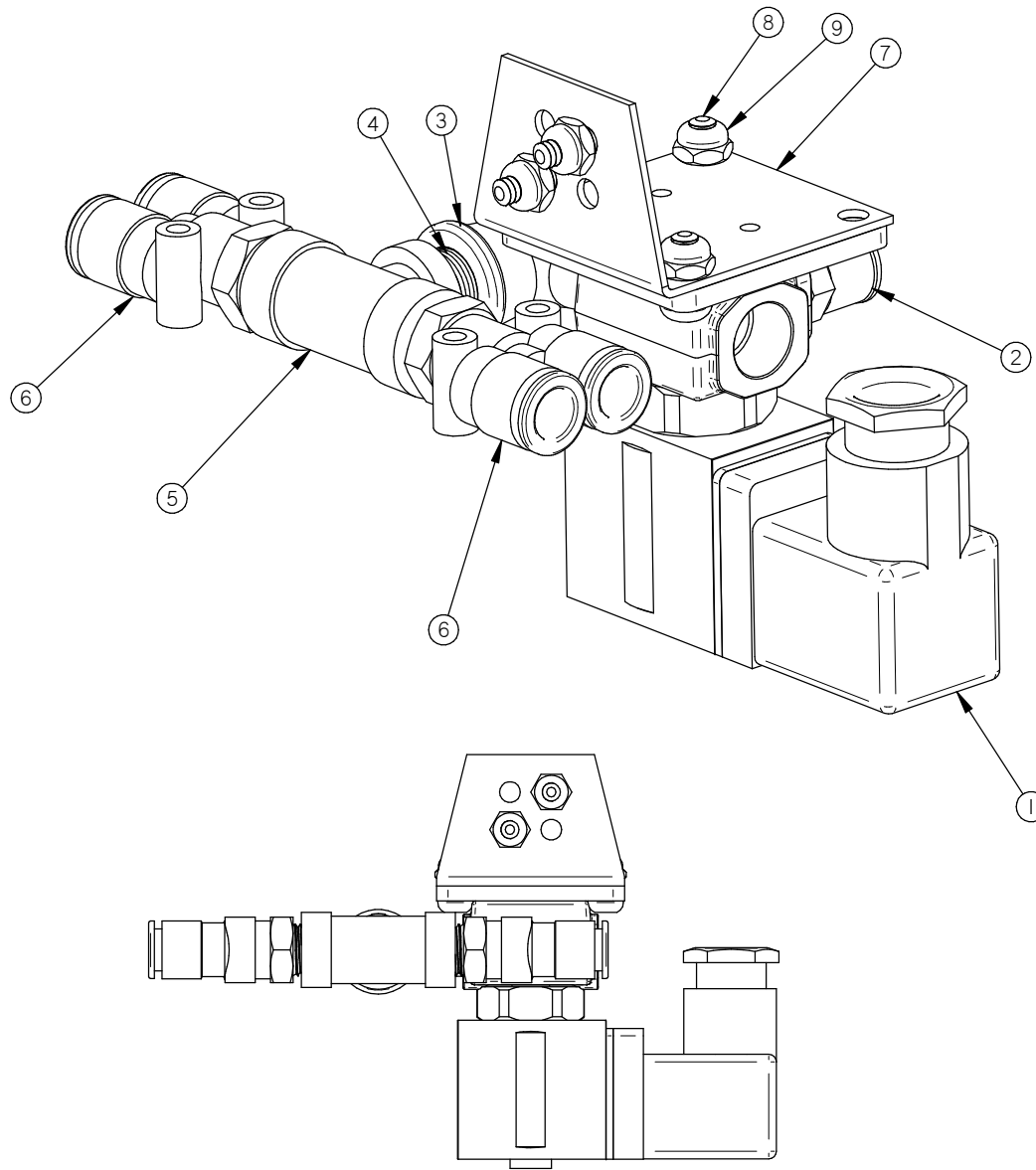

ITEM	PART #	DESCRIPTION	QT.
1	106-00701	VALVE 3WAY 24V 1/4"NPT	1
2	102-0410	MALE CONN.1/4"MNPTx3/8" T. QUICK	1
3	100-0065	STREET ELBOW 1/4" NPT SS	1
4	100-0225	CLOSE NIPPLE 1/4" NPT SS	1
5	100-0463	TEE 1/4" NPT S/S	1
6	102-0361	Y BRANCH 1/4" MNPT X 3/8" T. QUICK	2
7	001B6779	VALVE SUPPORT BRACKET	1
8	051-0144	SCREW #10-24 N.C 1/2"PAN PHIL. S/S	4
9	051-0572	NUT #10-24 NYLON LOCK S/S	4

A	VALVE UPDATE	14-05-27	SBU
LET.	MODIFICATION	DATE	INT.

MACHINE		VACUUM		DEPT. TOL.	METRIC	INCH	SIPROMAC ST-GERMAIN DE GRANTHAM QUEBEC CANADA
PART		BELLOWS VALVE ASSY		USINAGE	± 0.1	± 0.004"	
				TOLERIE	± 0.5	± 0.020"	
ITEM		CNC		SOUDEGE	± 0.5	± 0.020"	N.T.S.
MAT.		DWG BY SBU		DATE 14-05-27		DEPT. M QTY. 1	
		APP. BY		DATE		004B4104	

004B4105

ITEM	PART #	DESCRIPTION	QT.
1	001B6779	VALVE SUPPORT BRACKET	1
2	051-0144	SCREW #10-24 N.C 1/2" PAN PHIL. S/S	4
3	051-0572	NUT #10-24 NYLON LOCK S/S	4
4	100-0225	CLOSE NIPPLE 1/4" NPT SS	1
5	100-0463	TEE 1/4" NPT S/S	1
6	102-0330	ELBOW 1/4" NPT X 3/8" HOSE QUICK	3
7	102-0361	Y BRANCH 1/4" MNPT X 3/8" T. QUICK	1
8	106-00701	VALVE 3WAY 24V 1/4"NPT	1

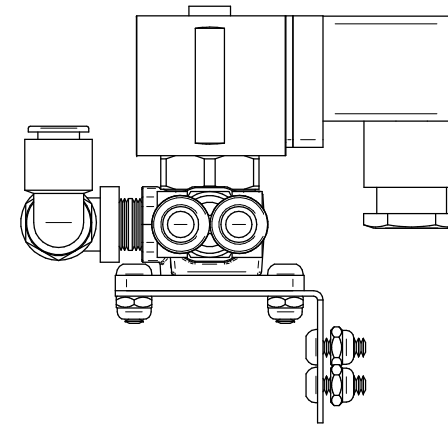
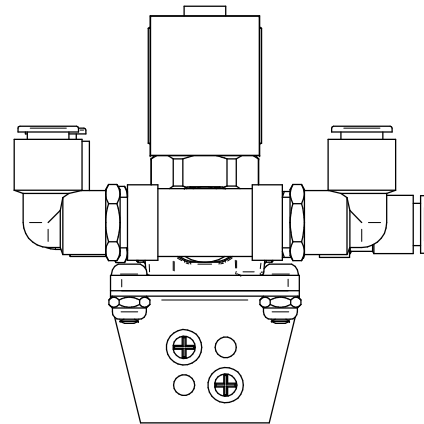
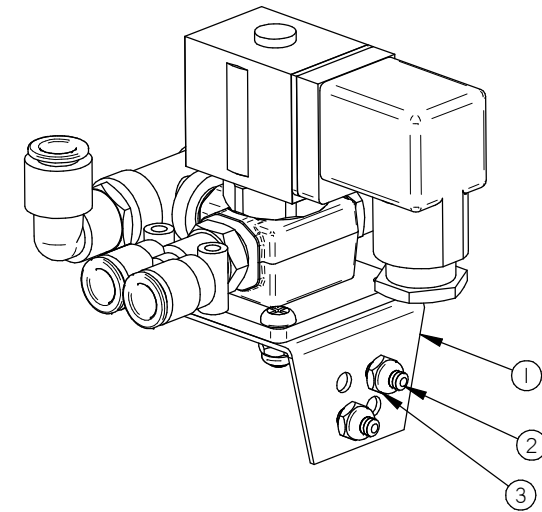
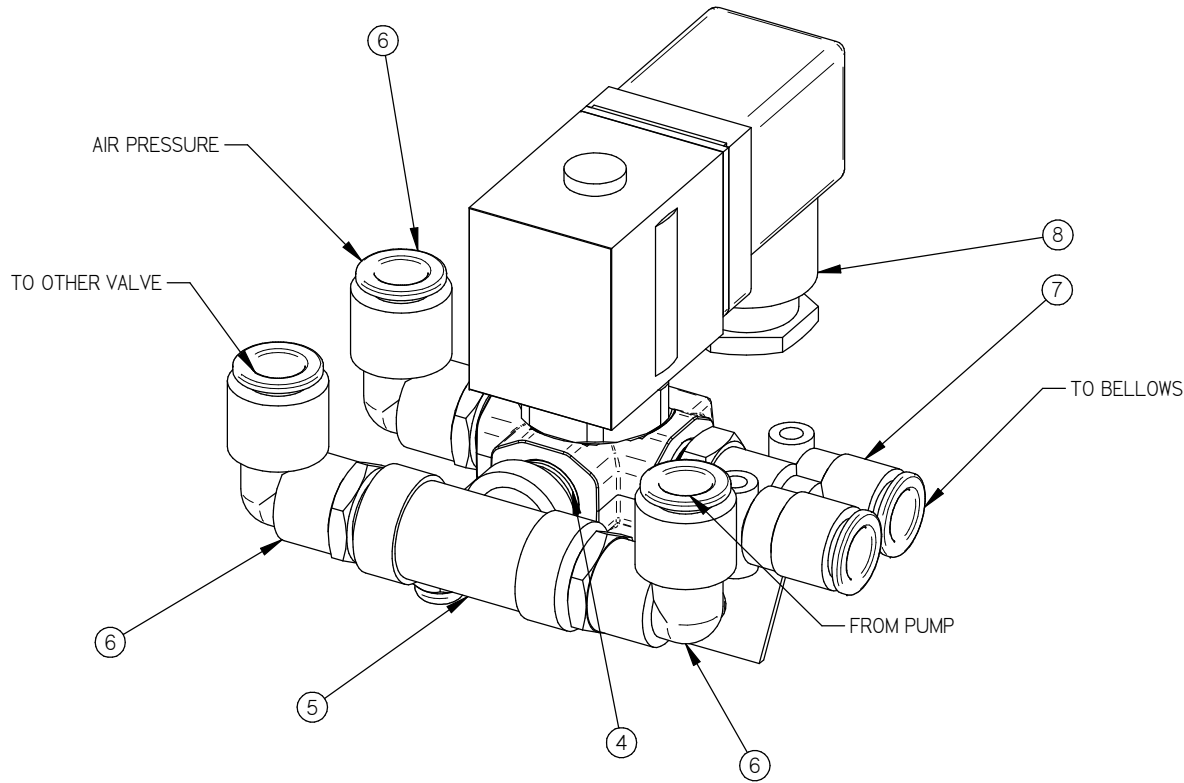

-OPTION - AIR REGULATOR

A	UPDATE VALVE	14-05-27	SBU
LET.	MODIFICATION	DATE	INT.

MACHINE		VACUUM		DEPT. TOL.	METRIC	INCH	SIPROMAC ST-GERMAIN DE GRANTHAM QUEBEC CANADA
PART		BELLOWS VALVE ASSY (OPT AIR REG)		USINAGE	± 0.1	± 0.004"	
ITEM		CNC		TOLERIE	± 0.5	± 0.020"	
MAT.		APP. BY		SOUDEGE	± 0.5	± 0.020"	N.T.S.
		DWG BY SBU		DATE 14-05-27		DEPT.	M
		APP. BY		DATE		NO.	1
						004B4105	

004B4103

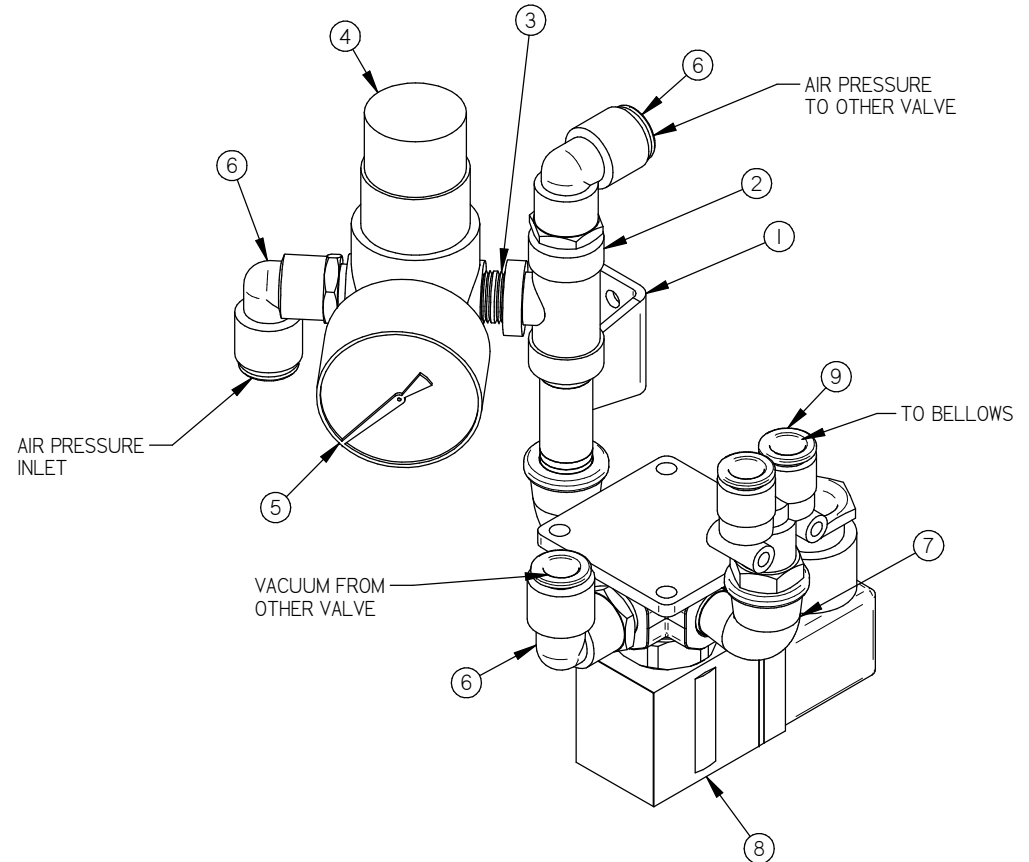
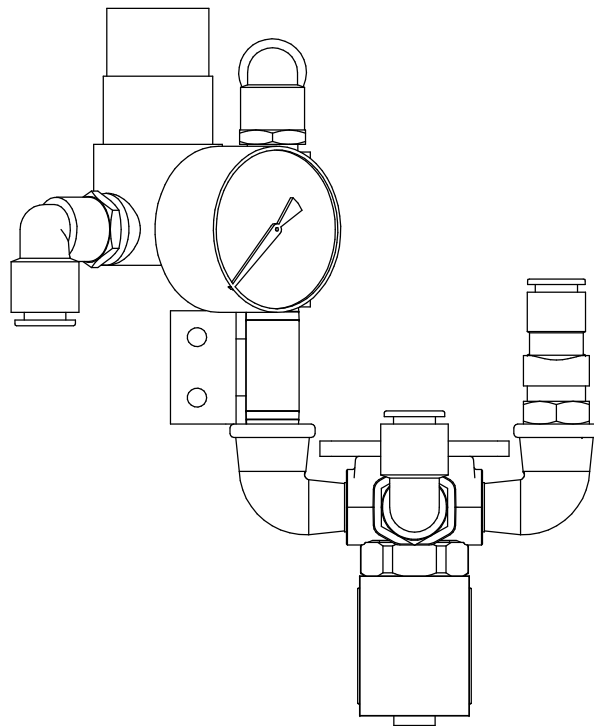
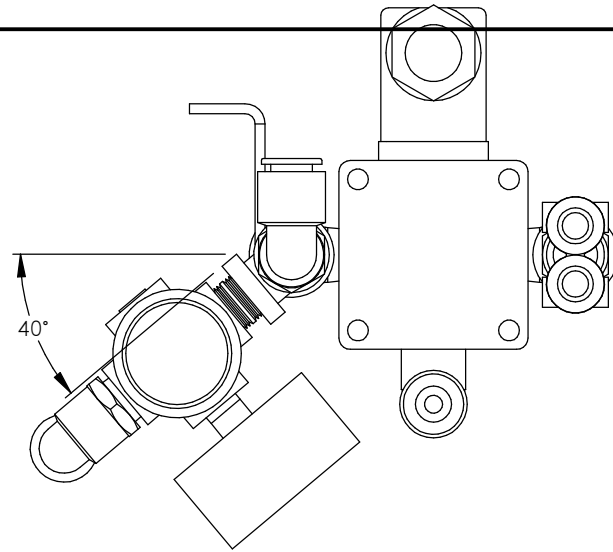

ITEM	PART #	DESCRIPTION	QT.
1	004A4140	AIR REGULATOR SUPPORT	1
7	100-0065	STREET ELBOW 1/4" NPT SS	2
3	100-0225	CLOSE NIPPLE 1/4" NPT SS	1
2	100-0463	TEE 1/4" NPT S/S	1
6	102-0330	ELBOW 1/4" NPT X 3/8" HOSE QUICK	3
9	102-0361	Y BRANCH 1/4" MNPT X 3/8" T. QUICK	1
8	106-00701	VALVE 3WAY 24V 1/4"NPT	1
4	114-0147	PRESSURE REGUL. 0-60 PSI 1/4" NPT	1
5	114-0245	PRESSURE GAUGE 60 PSI 1/8" NPT	1

-OPTION - AIR REGULATOR

MACHINE		600A & 620A		DEPT. TOL.	METRIC	INCH	SIPROMAC ST-GERMAIN DE GRANTHAM QUEBEC CANADA
PART		AIR REGULATOR VALVE ASSY		USINAGE	± 0.1	± 0.004"	
				TOLERIE	± 0.5	± 0.020"	
ITEM		CNC		SOUDEGE	± 0.5	± 0.020"	N.T.S.
MAT.		DWG BY SBU		DATE 14-05-27		DEPT. M	
		APP. BY		DATE		NO. 004B4103	

A	VALVE UPDATED	14-05-27	SBU
LET.	MODIFICATION	DATE	INT.

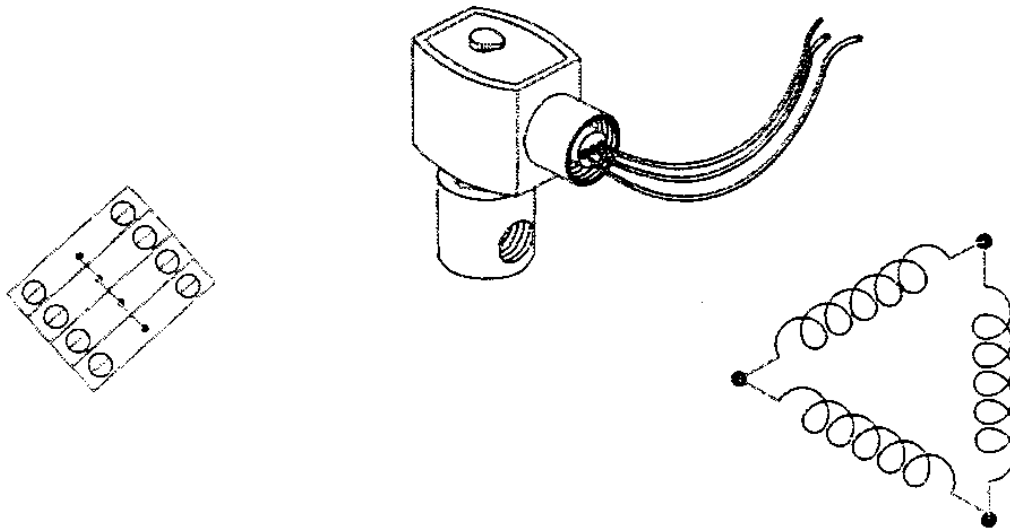

ELECTRICAL DRAWING

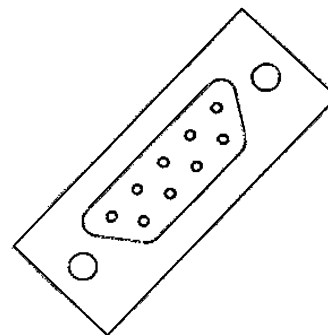
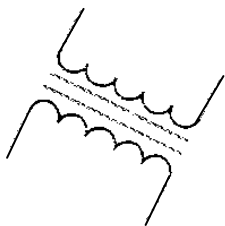

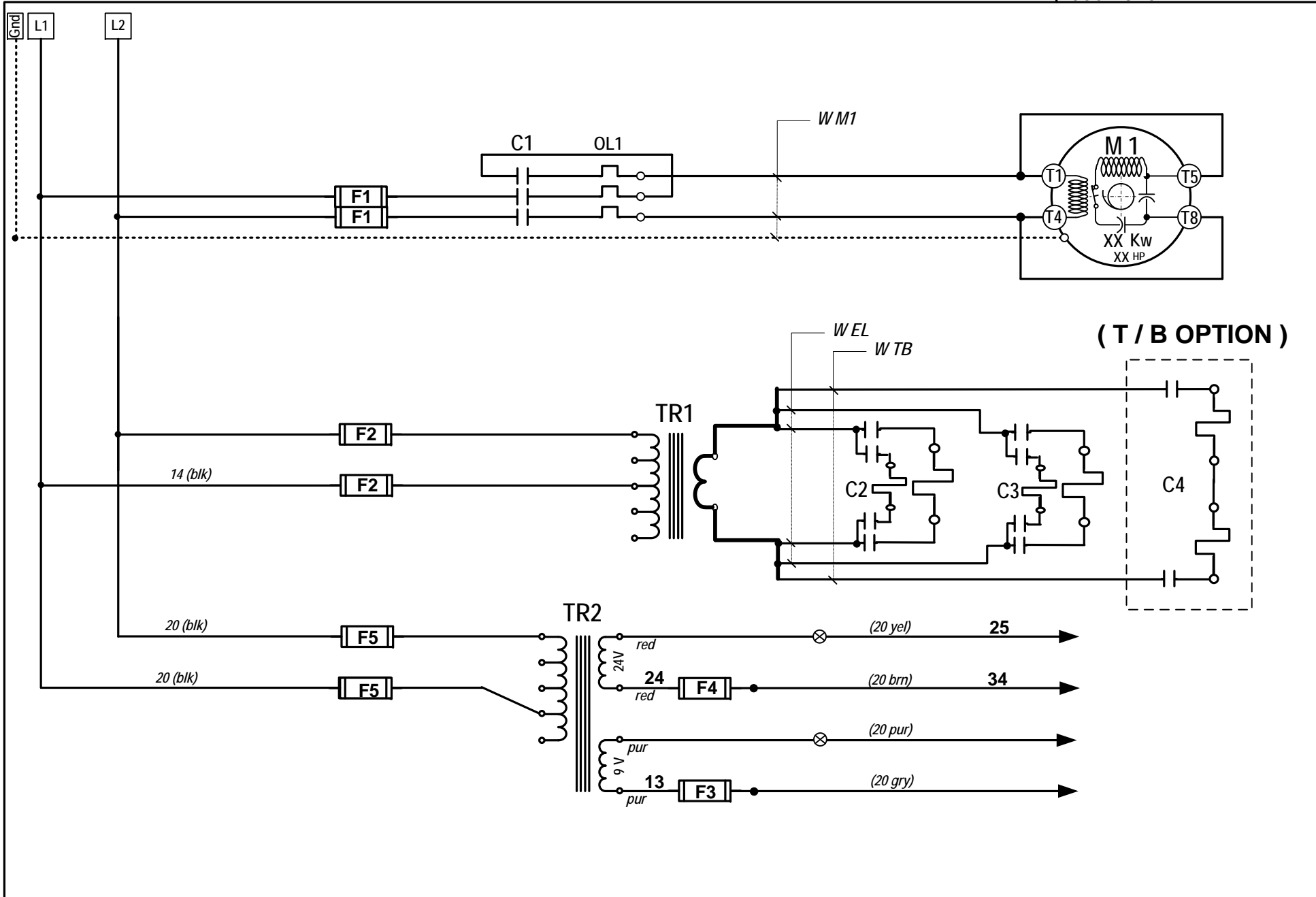

category	VACUUM PACK	model	600A	volt.	1Ph 60Hz				SIPROMAC	
system				circuit	year	month	day	block	St-Germain de Grantham QUEBEC, CANADA	
usual functions					05	01	18			
options				concept	draw	app	006-1320		PAGE	1 de 1
				PP	PP	DL				1

TRANSF.CONT.(yel 25)

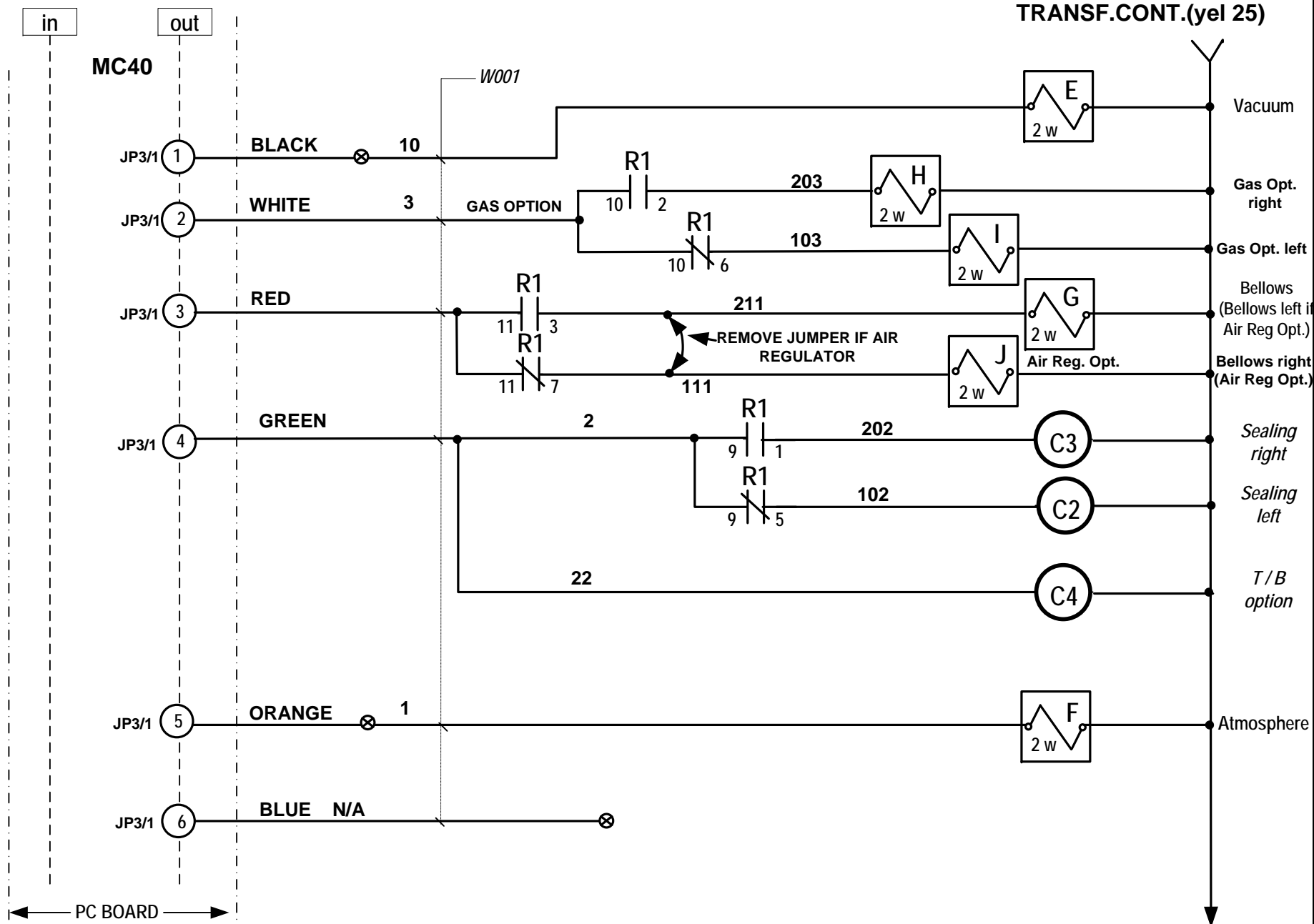

RC filters must be connected on each AC coil (not shown on diagram)

category	VACUUM PACK	model	600A & 620A	volt.	ALL				SIPROMAC St-Germain de Grantham QUEBEC, CANADA
system		circuit		year	month	day	block		
usual fonctions		concept	xx	10	08	18		006-1437 PAGE 1 de 3	
options		draw	xx						

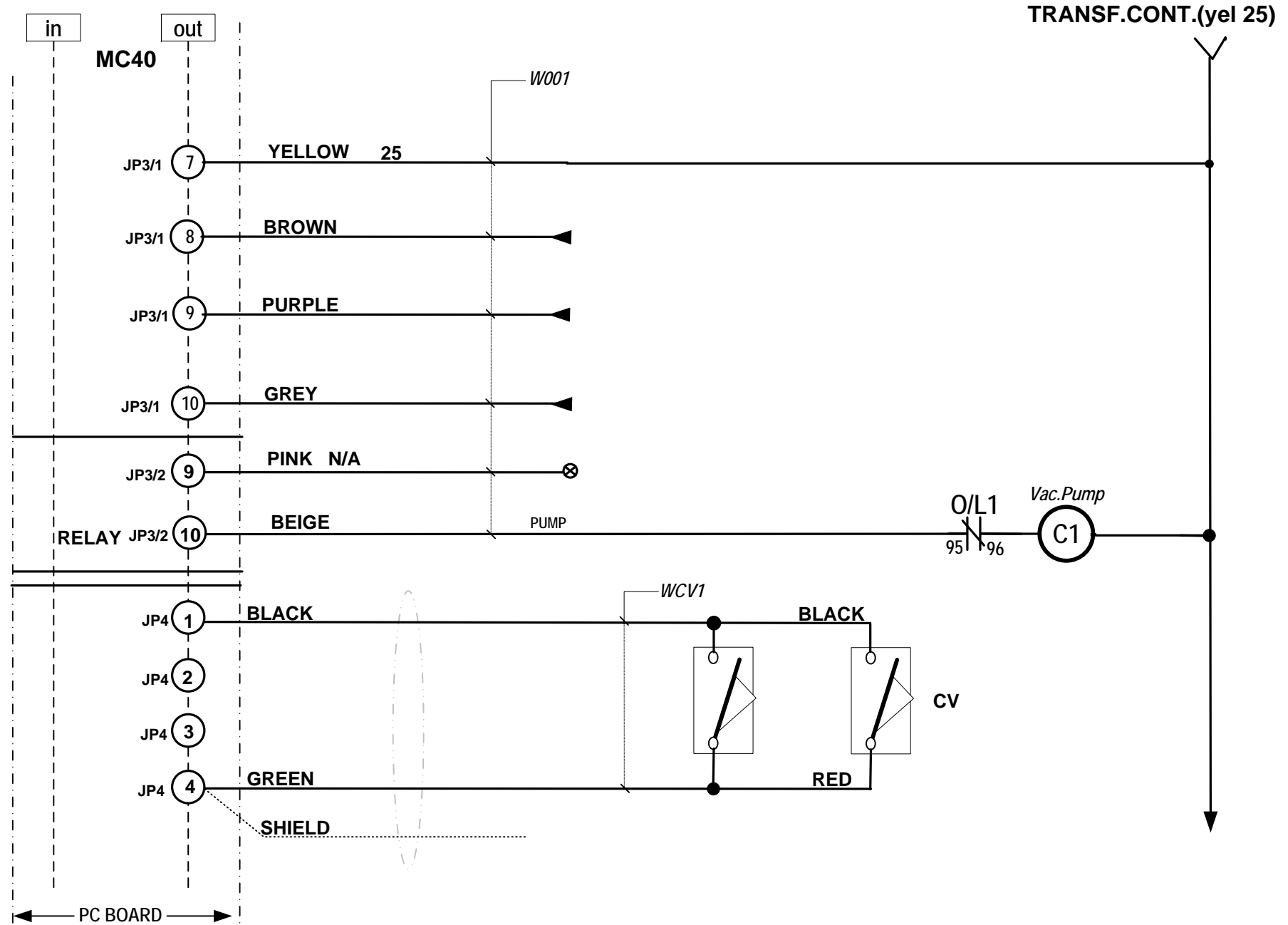

 *RC filters must be connected on each AC coil (not shown on diagram)*

category	VACUUM PACK	model	600A & 620A	volt.	ALL			
system				circuit	year	month	day	block
usual					10	08	18	
fonctions					concept	draw	app	006-1437 PAGE 2 de 3
options					XX	XX	XX	

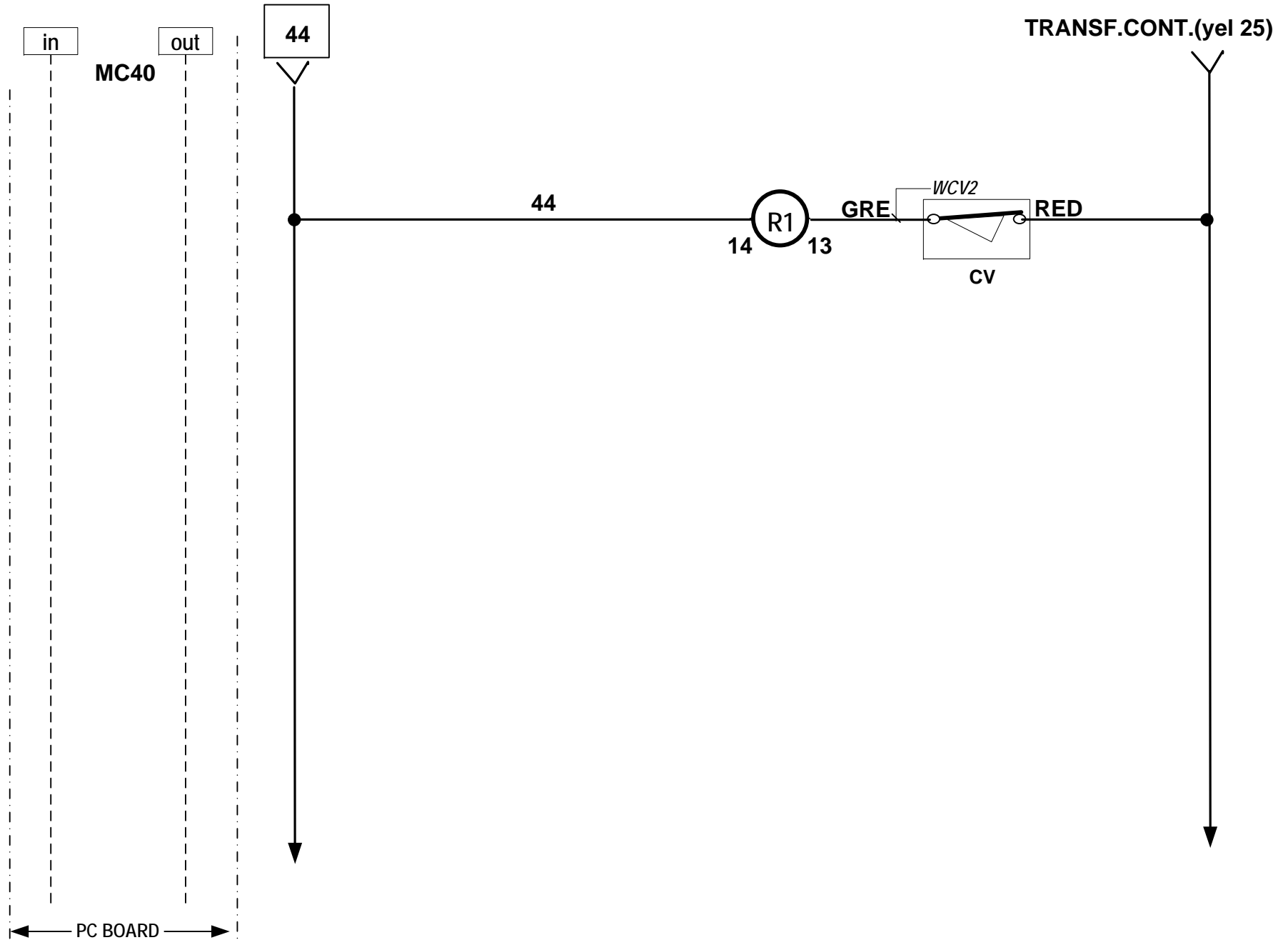

RC filters must be connected on each AC coil (not shown on diagram)

category	VACUUM PACK	model	600A & 620A	volt.	ALL				SIPROMAC St-Germain de Grantham QUEBEC, CANADA
system		circuit		year	month	day	block		
usual functions		concept	XX	draw	XX	app	XX	006-1437 PAGE 3 de 3	
options									

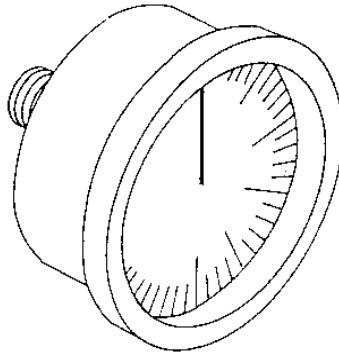

PNEUMATIC DRAWING

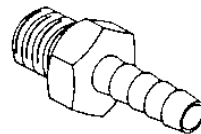
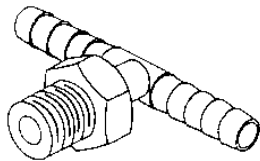

007-0019

ITEM	PART #	DESCRIPTION	QT.
1	106-0010	GAS VALVE	2*
2	114-0260	VACUUM GAUGE	1
3A	106-0070	BELLOWS VALVE	1
3B	106-0070	BELLOWS VALVE	1*
4	114-0147	PRESSURE REGULATOR	1*
5	114-0245	PRESSURE GAUGE	1*
6	114-0170	PRESSURE REGULATOR SUPPORT	1*
7	106-0030	ATMOSPHERE VALVE FOR 420A	1
	106-0030	ATMOSPHERE VALVE FOR 600A, 063M ³ AND 100 M ³	
	106-0050	ATMOSPHERE VALVE FOR 600A & 620A: 160 M ³ AND 250 M ³	
8	106-0050	ATMOSPHERE VALVE FOR 650A & 700A	1
	106-0030	VACUUM VALVE FOR 420A	
	106-0050	VACUUM VALVE FOR 600A & 620A	
106-0060	VACUUM VALVE FOR 650A & 700A		

*: OPTION

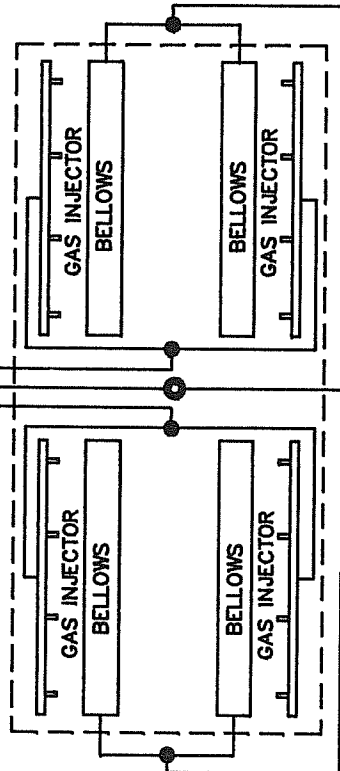
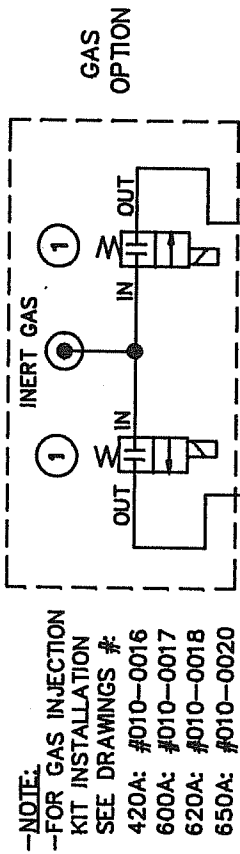

AIR REGULATOR OPTION

NOTE: SET TO A MAXIMUM OF 45 PSI

-NOTE:
-FOR AIR REGULATOR OPTION KIT INSTALLATION SEE DRAWINGS # 010-0019 & 650A: #010-0027 (FOR EXISTING MACHINES)

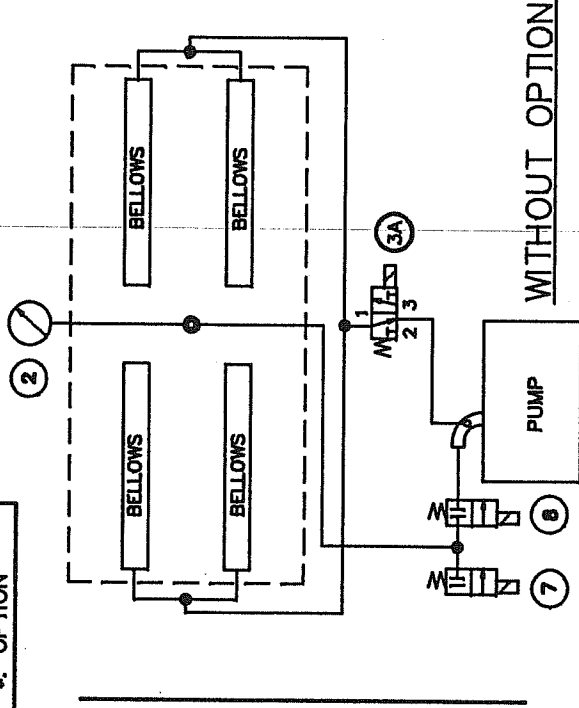

WITH OPTIONS

WITHOUT OPTION

MACHINE	420A, 600A, 620A & 650A	SIPROMAC	
PART	PNEUMATIC	ST-GERMAIN DE GRANTHAM, QUEBEC CANADA	
ITEM:	CNC	SCALE	1
MAT:	DWG M.LAVIGNE	DATE	97-03-11
APP:		NO.	007-0019
RE-DRAWN	MODIFICATION	DATE	
LET.		DATE	

MANUEL D'UTILISATEUR

MICROPROCESSEUR MC-40

AVEC OU SANS DÉTECTEUR DE VIDE

EMBALLEUSE SOUS VIDE

TABLE DES MATIÈRES

I INSTRUCTIONS POUR LES OPÉRATIONS

II MÉCANIQUE

- A- Vue de face
- B- Vue de l'arrière
- C- Procédure d'ajustement du couvert
- D- Schéma de l'assemblage de l'axe central
- E- Barres de scellage
(Double scellage)
- F- Dessin des barres de scellage
(Option du coupe sac électrique)
- G- Dessins des barres d'assemblage
(Scellage du haut et du bas en option)
- H- Gas injection kit installation drawing
(gaz injection option)

III ELECTRIQUE

- A- Schéma électrique (Bas voltage)
- B- Schéma électrique (Haut voltage à une phase)
- C- Schéma électrique (Haut voltage à 3 phases)
- D- Schéma électrique (Haut voltage 1 phase 50 Hz)
- E- Schéma électrique (Haut voltage 3 phase 50 Hz)

IV PNEUMATIQUE

- A- Schéma Pneumatique

EMBALLEUSES SOUS VIDE INSTRUCTIONS D'OPÉRATIONS

TABLE DES MATIÈRES

1. Mise en marche de la machine
2. Connexion Électrique
3. Opération
 - 3.1 Principes de travail
 - 3.2 Emballage Spécial
 - 3.2.1 Injection de Gaz
 - 3.2.2 Scellage haut et bas
(bi-active sealing)
 - 3.2.3 Coupe sac électrique
 - 3.3 Ajustement des contrôles digital
 - 3.4 Nettoyage Quotidien
4. Trouble de lancement
 - 4.1 Échec durant le cycle d'emballage
 - 4.2 Vide insuffisant
 - 4.2.1 Fuites dans le sac
 - 4.2.2 Pas de fuite dans le sac
 - 4.2.3 Vide insuffisant dans la chambre
 - 4.3 Scellage Inadéquat
 - 4.3.1 Scellage insuffisant
 - 4.3.2 Pas de scellage
 - 4.3.3 Courant ininterrompu sur les barres de scellage
 - 4.3.4 Le scellage ne tient pas
 - 4.4 Problème avec les valves
 - 4.5 Problème du panneau de contrôle
5. Maintenance Régulière

SIPROMAC INC.

EMBALLEUSES SOUS VIDE

1. MISE EN PLACE DE LA MACHINE:

Avant de choisir le site d'installation de votre machine, veuillez considérer que vous aurez besoin d'espace pour les produits emballés et non-emballés à part de l'espace occupé par la machine elle-même.

Bien vouloir vous rappelez que vous aurez besoin d'un sol bien au niveau pour votre installation. Spécialement avec les modèles mobiles, le poids de la pompe peut gauchir la machine et le couvercle ne fermera plus correctement.

Avant de commencer à travailler, vérifier l'huile de la pompe pour voir si elle est en quantité suffisante. Bien vouloir ne jamais utiliser une huile autre que celle recommandée par le fabricant. Ne pas excéder la quantité indiquée quand vous ajoutez ou faites le changement d'huile et faites votre vérification hebdomadairement.

En raison de la viscosité de l'huile, la machine sera plus difficile à démarrer à basses températures. Ainsi donc la pompe doit être placée dans un endroit où la température est d'au moins 50°F (+10°C). D'autre part, l'air doit circuler librement aux alentours de la pompe pour permettre le refroidissement dans les cas où la température des opérations atteindrait 160°F (70°C) ou la température maximale permise.

2. CONNEXION ÉLECTRIQUE:

Les connexions électriques doivent se faire par du personnel qualifié. La personne désignée doit s'assurer que les entrées électriques correspondent au voltage et à l'ampérage approprié de la machine.

Un schéma électrique accompagne chacune de nos machines.

Une étape importante dans le branchement de la machine est de s'assurer que le moteur de la pompe tourne dans une rotation appropriée.

Attention: Le moteur de la pompe ne devrait pas tourner plus de 3 ou 4 secondes dans une mauvaise rotation car il en résultera des dommages sérieux. La rotation est indiquée par une flèche sur le moteur de la pompe.

3. OPÉRATION:

3.1 Principes de travail:

Un emballage sous vide est un cycle composé de 3 étapes. Premièrement le vide est fait et l'air est complètement enlevé de la chambre et du sac contenant le produit. (Voir figure 1). Ensuite c'est possible d'injecter du gaz neutre par les conduits si le produit est très délicat. Finalement, un mécanisme pousse la barre de scellage sur le support de caoutchouc pour sceller le sac

Pour obtenir de beaux emballages, les produits et les sacs doivent être de taille proportionnelles. L'ouverture du sac ne devrait jamais excéder 2" (50cm) au delà des barres de scellage. Le produit doit être centré en hauteur par rapport aux barres de scellage en ajustant les écarteurs qui vous sont fournis.

Pour obtenir un bon scellage, assurez-vous qu'il n'y a pas de résidu de graisse qui reste entre les côtés intérieurs des sacs où le scellage doit être fait.

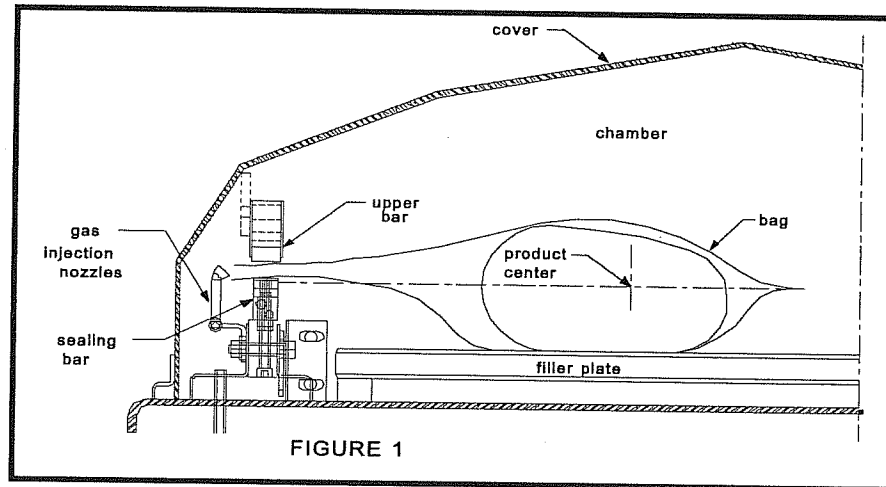

3.2 Emballage Spécial:

3.2.1 Injection de Gaz (option):

Il y a une pression atmosphérique de 14 lbs / pouce carré (= 1 kg / cm carré) sur les produits quand le vide demandé est atteint. Les produits qui peuvent être endommagés par une haute pression doivent être emballés avec un vide partiel et la pression doit être contrebalancée en injectant du gaz dans le sac (nitrogène ou dioxyde de carbone) avant le scellement et après avoir atteint le vide.

Pour l'injection de gaz, les sacs sont placés sur les barres de scellage, l'ouverture placée au dessus des conduits de gaz qui sont montés le long des barres de scellage. Après que le vide soit atteint, la valve du vide se ferme et la valve du gaz s'ouvre. Le pourcentage de gaz peut être ajusté par le menu du programme.

Le réservoir de gaz et la valve de pression qui est rattachée au réservoir ne sont pas fournis par Sipromac. La pression pour le régulateur de gaz devrait être ajustée approximativement à 5 lbs/pouce carré (1/3 Kg/cm carré). Chaque machine a un adaptateur pour la connexion de gaz quand l'option de l'injection de gaz est commandée.

3.2.2 Scellage Haut et Bas (optionnel):

Pour le scellage des sacs en aluminium comme pour le café il est impératif d'avoir une barre de scellage en haut et en bas.

3.2.3 Coupe sac électrique: (optionnel):

Cette option est utilisée pour obtenir un paquet dont l'excédent de film au niveau du scellage doit être coupée très près de la ligne de scellage. (cette option ne peut pas être utilisée avec le scellage Haut et Bas)

3.3 Les opérations de l'emballage sous vide:

Note: Reportez-vous aux menus structure de la page 8 et aux détails du panneau de contrôle sur la page 9

3.3.1 Bases:

Utilisez la touche "POWER" pour initier le bouton ON/OFF sur votre machine sous vide. Quand votre unité sera en fonction le dernier programme exécuté apparaîtra sur l'écran à cristaux liquides.

Utilisez la touche "ESC" pour passer du menu programme au menu fonctions et du menu des fonctions au menu des programmes.

Dans le menu des fonctions, utilisez la touche "SELECT" pour sélectionner une fonction et la touche "ENTER" pour exécuter la sélection.

Dans le menu des programmes, utilisez la touche "SELECT" pour sélectionner un programme et la touche "Enter" pour accéder ou modifier la sélection.

Dans les programmes du sous menu, utilisez la touche "ENTER" pour voir défiler les paramètres et lorsque ces derniers clignotent pour indiquer ils sont dans le mode d'acquisition. Quand la séquence de tous les paramètres se sont affichés, on revient automatiquement au début de la liste.

Dans les programmes du sous menu, utilisez la touche "ESC" pour revenir au menu des programmes. Pressez n'importe quelle touche pour effacer les messages d'erreur qui peuvent s'afficher sur l'écran à cristaux liquide.

3.3.2 Menu des fonctions:

3.3.2.1 Créer un programme:

Quand vous exécutez la fonction "create a program", le programme sous menu est atteint en commençant par l'identification. L'identification initiale "PxxNO NAME" est donné au programme et tous les paramètres sont établis à zéro; le numéro du programme est alloué automatiquement.

3.3.2.2 Supprimer un programme:

En exécutant la fonction de "delete a program", vous avez accès au menu des programmes et le numéro du premier programme en mémoire clignote pour indiquer le mode de suppression. Utilisez la touche "SELECT" pour sélectionner un programme et la touche "ENTER" pour avoir accès et confirmer la suppression de la sélection. Utilisez la touche "ESC" pour annuler une suppression et quitter la fonction. Quand vous quittez la fonction, le nombre des programmes actuels sur l'écran à cristaux liquides cesse de clignoter.

3.3.2.3 Choisir le mode d'opération:

Quand vous exécutez la fonction "Select Operating Mode", laquelle est disponible seulement pour les unités automatiques, la sélection en cours clignote pour vous indiquez le mode. Utilisez la touche "SELECT" pour parcourir les modes d'opération, lesquels sont automatiques, semi-automatiques et manuels.

Le mode d'opération sera validé et exécuté automatiquement. Utilisez la touche "ESC" ou "ENTER" pour quitter la fonction et retourner au menu des programmes.

3.3.3 Menu des Programmes:

3.3.3.1 Identification des Programmes:

Pour un programme sélectionné, choisissez l'identification en utilisant le panneau de contrôle numérique avec la chartre des caractères et pressez sur la touche numérique jusqu'à ce que le caractère soit sélectionné (4 x pour la valeur numérique). Utilisez la touche "ENTER" pour valider le caractère ainsi que la chaîne de caractères jusqu'à la fin (la nouvelle chaîne de caractères clignote). Vous pouvez utiliser la touche "ESC" pour revenir en arrière dans le cas où vous vous êtes trompé et que vous voulez effacer le caractère.

Exemple: EXAMPLE 1 → (9 caractères)

Touche 2, 2, ENTER	→ E
Touche 8, 8, 8, ENTER	→ X
Touche 1, ENTER	→ A
Touche 5, ENTER	→ M
Touche 6, ENTER	→ P
Touche 4, 4, 4, ENTER	→ L
Touche 2, 2, ENTER	→ E
Touche 9, 9, 9, ENTER	→ espace
Touche 1, 1, 1, 1, ENTER	→ 1

Touche ENTER pour valider la chaîne de caractères

3.3.3.2 L'ajustement du niveau de Vide (capteur de vide désactivé):

Pour un programme sélectionné, ajustez le niveau de vide, en secondes; la validation est automatiquement exécutée après la deuxième entrée digitale (Le nouveau temps de vide clignote). En cours de traitement, utilisez la touche "ENTER" pour valider la valeur du niveau de vide et la touche "ESC" pour revenir en arrière et changer la valeur du niveau de vide (La valeur du niveau de vide la plus ancienne clignotera à ce moment).

Exemples: 1 sec. → Touches 0, 1 ou 1, ENTER
15 sec. → Touches 1, 5

3.3.3.3 L'ajustement du niveau de Vide (capteur de vide en activé):

Pour un programme sélectionné, ajustez le niveau de vide avec les valeurs; le point décimal est automatiquement inséré suivant la deuxième entrée digitale et la validation est automatiquement exécutée après la troisième entrée digitale (La nouvelle valeur du niveau du vide clignote). Le niveau de vide est arrondi à la demie la plus près de la valeur. En cours de traitement, utilisez la touche "ENTER" pour valider la valeur du niveau de vide et la touche "ESC" pour revenir en arrière et changer la valeur du niveau de vide (La valeur du niveau de vide la plus ancienne clignotera à ce moment). Ajustez le niveau du vide à zéro pour pouvoir contourner le capteur de vide et procédez en réglant seulement le " Temps de vide Plus" (Vacuum plus time).

Exemples: 90.0% → Touches 9, 0, 0 ou 9, 0, ENTER ou
Touches 9, 0, 1 ou 9, 0, 2 or 9, 0, 3 ou 9, 0, 4
97.5% → Touches 9, 7, 5 ou
Touches 9, 7, 6 ou 9, 0, 7 or 9, 0, 8 ou 9, 0, 9
0.0% → Touches 0, 0, 0 ou 0, ENTER

3.3.3.4 Ajustement du Temps de Vide "Plus" (capteur de vide activé):

Pour un programme sélectionné, réglez le "temps de vide plus" en secondes; la validation est automatiquement exécutée après la deuxième entrée digitale (La nouvelle valeur du "temps de vide plus" clignotera à ce moment). En cours de traitement, utilisez la touche "ENTER" pour valider la nouvelle valeur du "temps de vide plus" et la touche "ESC" pour revenir et recommencer avec de nouvelles valeurs (la valeur la plus ancienne du "temps de vacuum plus" clignotera).

Exemples: 1s → Touche 0, 1 or 1, ENTER
15s → Touche 1, 5

3.3.3.5 Ajustement de l'injection de gaz (capteur de vide désactivé):

Pour sélectionner un programme placer le niveau d'injection de gaz en suivant la même procédure que pour le niveau de vide. Gardez en mémoire que plus le temps d'injection de gaz est haut, moins la pression du sellage sera forte. Un certain niveau de vide doit être maintenu pour un bon fonctionnement.

3.3.3.6 Ajustement de l'injection de gaz (capteur de vide activé):

Pour sélectionner un programme placer le niveau d'injection de gaz en suivant la même procédure que pour le niveau de vide; L'ajustement pour le gaz le plus haut devrait être de 10% au-dessous du niveau de l'ajustement de vide.

3.3.3.7 Ajustement du cachetage:

Pour sélectionner un programme le temps de cachetage, en commençant par les secondes; le point décimale est automatiquement insérée après la première entrée de chiffre et la validation est automatiquement effectuée après la troisième entrée de chiffre (le nouveau temps de cachetage clignote). Le temps de cachetage est arrondi à la moitié la plus proche du cent. À un milieu l'entrée des données, utiliser la clé "ENTER" pour valider l'heure du cachetage et la clé " ESC " pour revenir en arrière et reprogrammer le temps cachetage avec de nouvelles données (le vieux temps de cachetage clignote).

Exemples: 4.50s → clés 4, 5, 0 or 4, 5, ENTER or
clés 4, 5, 1 or 4, 5, 2 or 4, 5, 3 or 4, 5, 4
2.35s → clés 2, 3, 5 or
clés 2, 3, 6 or 2, 3, 7 or 2, 3, 8 or 2, 3, 9
0.00s → clés 0, 0, 0 or 0, ENTER

3.3.4 Exécution de cycle de vide :

Pour les unités manuels ainsi que les unités automatiques faire la mise en marche manuelle, fermer le couvercle afin de lancer un cycle de vide. Pour l'unité automatique faire mise en marche semi-automatique ou automatique, utilisez le bouton "ARRÊT / DÉBUT" pour lancer ou interrompre un cycle de vide. Le programme sélectionné peut être lancé seulement dans le programme du menu, au moment où aucune modification n'est nécessaire, et l'accès des autres programmes et des fonctions ne sont pas requis. Pendant l'exécution du cycle le statut d'opération est séquentiellement affiché sur l'écran à cristaux liquides, excepté pour les paramètres établis à zéro, qui ne sont pas montrés:

- niveau de vide de la chambre pendant la séquence,
- vide additionné du temps pendant le vide plus la séquence,
- niveau de vide de la chambre pendant la séquence d'injection de gaz,
- statut de temps de cachetage pendant la séquence de cachetage,
- niveau de vide de la chambre pendant La séquence d'atmosphère .7

Pendant l'exécution du cycle, utilisé la clef "1" pour interrompre la séquence de vide et pour exécuter la séquence suivante, soit l'injection du gaz ou le cachetage, suivi de la clé "ENTER" afin d'accéder et modifier le programme; les paramètres deviennent valides seulement pour les cycles suivants de vide.

3.3.5 System monitor:

Pour accéder le menu des diagnostics, monter la puissance de la machine d'emballage sous vide tout en maintenant le bouton "ESC" enfoncé. Utilisez la clé "SELECT" pour choisir la fonction du système du moniteur et "ENTER" pour accéder et visualiser les paramètres surveillés. Employez la clé "SELECT" pour changer la révision de logiciel, la quantité d'heures de travail faites et de la quantité de cycles complets exécutés depuis la première initialisation.

