

# VACUUM PACKAGING MACHINE

## MODEL 450T

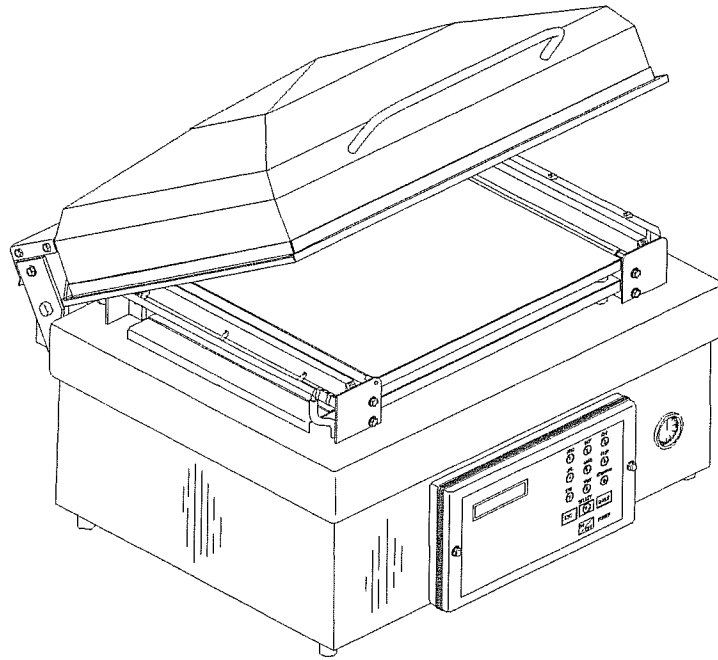

### OWNERS MANUEL (MANUEL D'UTILISATION) (MANUAL DE UTILIZACION)



## IMPORTANT SAFETY INSTRUCTIONS

### SAVE THESE INSTRUCTIONS



This symbol points out important safety instructions which, if not followed, could endanger the personal safety and/or property of yourself and others. Read and follow all instructions in this manual before attempting to operate your machine. Failure to comply with these instructions may result in personal injury.

### General Operation

- Read, understand, and follow all instructions in the manual and on the machine before starting. Keep this manual in a safe place for further and regular reference and for ordering replacement parts.
- Only allow responsible individuals familiar with the instructions to operate the machine. Be sure to know controls and how to stop the machine quickly.
- Never put your hands near moving parts.
- Only allow qualified individuals for the maintenance of your machine.
- Remove all obstacles, which may interfere with the machine functions.
- Clear the work area such as electrical wires, buckets, knives etc.
- Be sure that everyone else is clear of your work area before operating the machine.
- Do not sit nor stand on the machine.
- Always turn off the machine after your work is done. Never leave a running machine unattended.
- Always disconnect and wait till the machine has cooled before attempting any maintenance.
- Do not wear loose fitting clothes or jewelry as they may get caught in moving parts of the machine.
- Always wear security shoes, to prevent injury caused by moving the machine or objects falling from the machine.
- Never exceed the time limit to seal, which is recommended by the manufacturer. This is to avoid any damage that may be caused to the sealing bars and to eliminate the risk of fire in the machine. Thus avoiding corporal burns.
- Never touch the sealing bars after they have been used, this will avoid corporal burns. Wait a few minutes to let the machine cool down before touching.
- Always make sure that the sealing bars are well installed in their "Guide Blocks" before starting a cycle.
- Never incline the machine more than 30 degrees, it may tip over and hurt someone seriously.
- Work only in daylight or good artificial light.

**Do not operate the machine while under the influence of alcohol or drugs!**

## **Service**

- Use proper containers when draining the oil. Do not use food or beverage containers that may mislead someone into drinking from them. Properly dispose of the containers, or store in a safe place immediately following the draining of the oil.
- Prior to disposal, determine the proper method to dispose of waste from your local office of Environmental Protection Agency. Recycling centers are established to properly dispose of materials in an environmentally safe fashion.

**Do not pour oil or other fluids into the ground, down a drain or into a body of water.**



Warning-Your responsibility:

**This machine should only be operated by personal who can read, understand and respect warnings and instructions regarding this machine in the owners manual. Save these instructions for future reference.**

# VACUUM PACKAGING MACHINE

## MODEL 450T

**(MC-40 SIPROMAC)**

### GENERAL TABLE OF CONTENTS

#### I OPERATION INSTRUCTIONS

#### II MECHANICAL

- A- 450T Front view assembly drawing
- B- 450T Rear view assembly drawing
- C- P.C. board support drawing
- D- 450T Structure assembly drawing
- E- Seal bar assembly drawings (twin seal)
- F- Seal bar assembly drawings (electrical bag cut option)
- G- Cover assembly drawings
- H- Gas injection kit installation drawing  
(gas injection option)
- J- Lift kit installation drawing (lift kit option)

#### III ELECTRICAL

- A- Electrical drawings

#### IV PNEUMATIC

- A- Pneumatic drawing



# VACUUM PACKAGING MACHINES-OPERATION INSTRUCTIONS

## TABLE OF CONTENTS

1. Setting up the machine
2. Electrical connection
3. Operation
  - 3.1 Working principles
  - 3.2 Special packaging
    - 3.2.1 Gas flushing
    - 3.2.2 Electrical bag cut (optional)
  - 3.3 Vacuum packaging operation
    - 3.3.1 Basics
    - 3.3.2 Functions menu
      - 3.3.2.1 Create a program
      - 3.3.2.2 Delete a program
      - 3.3.2.3 Select operating mode
    - 3.3.3 Programs menu
      - 3.3.3.1 Program identification
      - 3.3.3.2 Vacuum time setting (sensor disabled)
      - 3.3.3.3 Vacuum level setting (sensor enabled)
      - 3.3.3.4 Vacuum plus time setting (sensor enabled)
      - 3.3.3.5 Gas time setting (sensor disabled)
      - 3.3.3.6 Gas flush level setting (sensor enabled)
      - 3.3.3.7 Sealing time setting
    - 3.3.4 Vacuum cycle execution
    - 3.3.5 System monitor
  - 3.4 Daily cleaning
4. Trouble shooting
  - 4.1 Failure during a packaging cycle
  - 4.2 Insufficient vacuum
    - 4.2.1 Leakage in the bag
    - 4.2.2 No leakage in the bag
    - 4.2.3 Insufficient vacuum in the chamber
  - 4.3 Faulty seal
    - 4.3.1 Insufficient seal
    - 4.3.2 No seal
    - 4.3.3 Permanent sealing current
    - 4.3.4 Seal does not stick
  - 4.4 Fault in the valves
  - 4.5 Control board failure
5. Regular maintenance

2010-08-30

# VACUUM PACKAGING MACHINES

## **1. SETTING UP THE MACHINE:**

Before choosing the site for the machine, please consider that you will also need room for packaged and non-packaged products apart from the space needed for the machine itself.

Keep in mind that the machine must not be set up upon uneven ground. Especially with mobile models, the weight of the pump might then cause warping of the machine. Then the lid will not fit correctly.

Before starting to work, check the oil view glass on the pump, if there is a sufficient quantity of oil in the pump. Never use oil other than recommended by the producer. Never exceed maximum quantity of oil indicated, when adding or changing oil. Verify weekly.

Normal ambient temperature for the vacuum pump is between 10 to 70°C. For temperature below 10°C; it is recommended to use synthetic oil. Please consult factory and pump manufacturer manual for more information or when ambient temperature are outside normal limits.

## **2. ELECTRICAL CONNECTION:**

Electrical connections must be made by qualified personnel. This person must make sure that the electrical entries correspond to the proper voltage and amperage of the machine. **GROUNDING INSTRUCTIONS:** This appliance must be grounded. In the event of malfunction or breakdown, grounding provides a path of least resistance for electric current to reduce the risk of electric shock. This appliance is equipped with a cord having an equipment-grounding conductor and a grounding plug. The plug must be plugged into an appropriate outlet that is properly installed and grounded in accordance with all local codes and ordinances.

**DANGER** Improper connection of the equipment-grounding conductor can result in a risk of electric shock. The conductor with insulation having an outer surface that is green with or without yellow stripes is the equipment-grounding conductor. If repair or replacement of the cord or plug is necessary, do not connect the equipment-grounding conductor to a live terminal. Check with a qualified electrician or serviceman if the grounding instructions are not completely understood, or if in doubt as to whether the appliance is properly grounded. Do not modify the plug provided with the appliance if it will not fit the outlet; have a proper outlet installed by a qualified electrician.

All vacuum machines are supplied with an electrical schematic drawing. An important step in connecting the machine is to make sure that the pump turns in its correct rotation.

**The pump should not rotate more than 3 to 4 seconds in the wrong rotation or it**



may cause serious damage. The proper rotation is indicated by an arrow on the pump motor.

### **3.OPERATION:**

#### **3.1 Working principles:**

A vacuum packaging cycle is made of 3 stages. First the vacuum is made, the air is completely taken out of the chamber and from bag containing the product. (See figure 1). Then it is possible to inject neutral gas from the nozzles, if the product is delicate. Finally, a mechanism pushes the sealing bar to the rubber support to seal the bag.

To obtain nice packages, the products and the bags have to be of proportional sizes. The bag's opening should never exceed 50 cm(2") past the seal bars. The product should be centered in height in relation to the seal bar by adjusting the spacers provided.

To obtain a good seal, make sure that no residue of fat is left between the bag's inner sides where sealing is done.

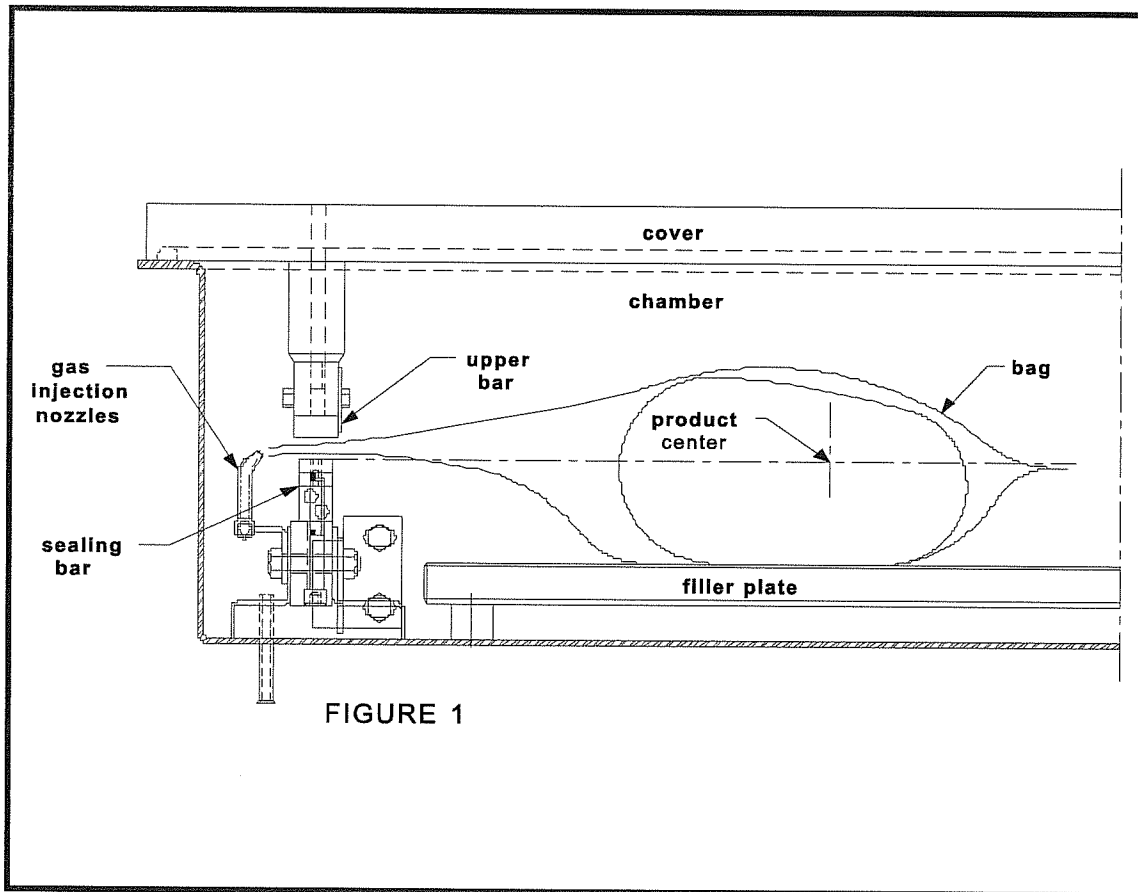

#### **3.2 Special packaging:**

##### **3.2.1 Gas flushing (option):**

There is an atmospheric pressure of 1 kg/ sq. cm (14 lbs/sq. inch) upon products when fully evacuated. Products which can be damaged by high pressure must be packaged with a partial vacuum, or the pressure must be counterbalance by inflating the bag with gas (nitrogen or carbon dioxide) before sealing after evacuation.

For gas flushing, the bags are placed on the sealing bars, the open end placed over the gas nozzles mounted alongside the sealing bar. After evacuation, the vacuum valve closes and the gas valve opens. Gas time (sec.) can be set in the program menu.

The necessary gas tank and pressure valve mounted on tank is not supplied, The pressure of the gas regulator should be set at approximately 1/3 kg/sq. cm ( 5 lbs/sq.inch.). Each machine has an adaptor for gas connection when gas flush option is ordered.

### **3.2.2 Electrical bag cut (optional):**

This option is used to obtain a package that the excess bagtail is cut off close to the seal (cannot be used with top and bottom sealing).

## **3.3 Vacuum packaging operation:**

Note: Refer to the menus structure on page 13 and the keyboard detail on page 14.

### **3.3.1 Basics:**

Use key "POWER" to power ON / OFF the vacuum packaging machine. When the unit is energized, the identification of the last executed program is displayed on LCD screen. To disconnect, use the "POWER" key to turn off the machine , then remove plug from outlet. Do not unplug by pulling on cord. To unplug, grasp the plug, not the cord. Unplug from outlet when not in use and before servicing or cleaning.

Use the "ESC" key to change over from the programs menu to the functions menu and from the functions menu to the programs menu.

In functions menu, use key "SELECT" to select a function and key "ENTER" to accede and executed the selection.

In programs menu, use key "SELECT" to select a program and key "ENTER" to accede and modify the selection.

In programs submenu, use key "ENTER" to pass over the parameters and point to the following one; the parameters are blinking to point out the acquisition mode. A return to programs menu is performed automatically following the last parameter acquisition.

In program submenu, use key "ESC" to get back to the programs menu. Strike any key to clear the error messages which may be displayed on LCD screen.

### **3.3.2 Functions menu:**

#### **3.3.2.1 Create a program:**

When executing the "create a program" function, the program submenu is acceded, starting with the identification. The initial identification "Pxx NO NAME" is given to the program and all parameters are established to zero; the program number is allocated automatically.

#### **3.3.2.2 Delete a program:**

When executing the "delete a program" function, the programs menu is acceded and the number of the first program in memory is blinking to point out the deletion mode. Use key "SELECT" to select a program and key "ENTER" to accede and confirm deletion of the selection. Use key "ESC" to unconfirm a deletion and to leave the function. When leaving the function, the number of the actual program on LCD screen cease to blink.

#### **3.3.2.3 Select operating mode:**

When executing the "select operating mode" function, which is available only for the automatic units, the actual selection is blinking to point out the acquisition mode. Use key "SELECT" to get through the operating modes, which are automatic, semi-automatic and manual; the validation of the selected operating mode is performed automatically. Use key "ESC" or "ENTER" to leave the function and get back to the program menu.

### **3.3.3 Programs menu:**

#### **3.3.3.1 Program identification:**

For a selected program, set the identification, using the numeric keyboard characters chart; press numeric key until the desired character is selected (4 times for the numeric value). Use key "ENTER" to validate the character and to validate the characters string at the end(the new characters string is blinking). In a middle of an acquisition, use key "ESC" to come backward and erase one or several characters.

**Example: EXAMPLE 1** → keys 2, 2, ENTER → E  
(9 characters) keys 8, 8, 8, ENTER → X  
keys 1, ENTER → A  
keys 5, ENTER → M  
keys 6, ENTER → P  
keys 4, 4, 4, ENTER → L  
keys 2, 2, ENTER → E  
keys 9, 9, 9, ENTER → space  
keys 1, 1, 1, 1, ENTER → 1  
key ENTER to validate the characters string

### **3.3.3.2 Vacuum time setting (sensor disabled):**

For a selected program set the vacuum time, in seconds; the validation is automatically performed following the second digit entry (the new vacuum time is blinking). In a middle of an acquisition, use key "ENTER" to validate the vacuum time and key "ESC" to come backward and start over with a new acquisition (the old vacuum time is blinking).

**Examples:** 1s → keys 0, 1 or 1, ENTER  
15s → keys 1, 5

### **3.3.3.3 Vacuum level setting (sensor enabled)**

For a selected program set the vacuum level, starting with the values; the decimal point is automatically inserted following the second digit entry and the validation is automatically performed following the third digit entry (the new vacuum level is blinking). The vacuum level is rounded off to the nearest half value. In the middle of an acquisition, use key "ENTER" to validate the vacuum level and key "ESC" to come backward and start over with a new acquisition (the old vacuum level is blinking). Set vacuum level to zero to bypass the pressure transducer and proceed only using the vacuum plus time.

**Examples:** 90.0% → keys 9, 0, 0 or 9, 0, ENTER or  
keys 9, 0, 1 or 9, 0, 2 or 9, 0, 3 or 9, 0, 4  
97.5% → keys 9, 7, 5 or  
keys 9, 7, 6 or 9, 0, 7 or 9, 0, 8 or 9, 0, 9  
0.0% → keys 0, 0, 0 or 0, ENTER

### **3.3.3.4 Vacuum plus time setting (sensor enabled)**

For a selected program set the vacuum plus time, in seconds; the validation is automatically performed following the second digit entry (the new vacuum plus time is blinking). In a middle of an acquisition, use key "ENTER" to validate the vacuum plus time and key "ESC" to come backward and start over with a new acquisition (the old vacuum plus time is blinking).

**Examples:** 1s → keys 0, 1 or 1, ENTER  
15s → keys 1, 5

### **3.3.3.5 Gas time setting (sensor disabled)**

For a selected program set the gas time setting following the same procedure as for the vacuum time. Keep in mind that increasing gas time decrease sealing pressure. Some vacuum must be kept inside to assure proper functioning.

### **3.3.3.6 Gas flush level setting: (sensor enabled)**

For a selected program set the gas flush level following the same procedure as for the vacuum level; the maximum gas flush level setting is 10% below the vacuum setting.

### **3.3.3.7 Sealing time setting:**

For a selected program set the sealing, starting with the seconds; the decimal point is automatically inserted following the first digit entry and the validation is automatically performed following the third digit entry (the new sealing time is blinking). The sealing time is truncated to the nearest half hundredth. In a middle of an acquisition, use key "ENTER" to validate the sealing time and key "ESC" to come backward and start over with a new acquisition (the old sealing time is blinking).

**Examples:** 4.50s → keys 4, 5, 0 or 4, 5, ENTER or  
keys 4, 5, 1 or 4, 5, 2 or 4, 5, 3 or 4, 5, 4  
2.35s → keys 2, 3, 5 or  
keys 2, 3, 6 or 2, 3, 7 or 2, 3, 8 or 2, 3, 9  
0.00s → keys 0, 0, 0 or 0, ENTER

### **3.3.4 Vacuum cycle execution:**

For the manual units and the automatic units set on manual, close the cover to initiate a vacuum cycle. For the automatic units set on semi-automatic or on automatic, use push button "STOP / START" to initiate or interrupt a vacuum cycle. A selected program can be initiated only in the programs menu, when no modifications are in progress, and the access to the other programs and functions is denied. During cycle execution the operation status is sequentially displayed on LCD screen, except for the parameters established to zero, which are not displayed:

- Vacuum time or vacuum % status during vacuum sequence,
- Gas time or gas % status during gas flush sequence,
- Sealing time status during sealing sequence,
- ATM message during atmosphere sequence.

During cycle execution, use key "1" to abort the vacuum sequence and execute the following sequence, which is gas flush or sealing, and key "ENTER" to accede and modify the program; the parameters become valid only for the following vacuum cycles.

### **3.3.5 System monitor:**

To accede the diagnostics menu, power up the vacuum packaging machine while keeping pushed in the "ESC"key. Use key "SELECT" to select the system monitor function and key "ENTER" to accede and visualize the monitored parameters. Use key "SELECT" to change over from the software revision, the amount of working hours done and the amount of complete cycles performed since first initialization.

## -MENUS STRUCTURE-

- **Functions menu:**
  - "F1 CREATE A PRGM"
  - "F2 DELETE A PRGM"
  - "F3 SELECT OPMODE" (automatic units only)
- **Programs menu:**
  - "Pxx NAME"
  - Program submenu:
    - "VACUUM: xx.x%" (10.0% - 99.5%)
    - "VACUUM PLUS: xxs" (0s - 99s)
    - "VACUUM: xx.xs" (10 – 199s) (sensor disabled in D8 menu)
    - "GAS FLUSH: xx.xs" (0 – 99s) (units with gas option) (sensor disabled in D8)
    - "GAS FLUSH: xx.x%" (0.0% - 10% below the vacuum level) (units with gas option)
    - "SEAL TIME: x.xxs" (0.00s - maximum unit allocated setting)
    - "Pxx NAME" (12 characters)
- **Diagnostics menu** (keys "ESC" & "POWER" for access):
  - "DIAGNOSTICS MENU" (access code required)
  - "D1 INPUTS TEST"
  - "D2 OUTPUTS TEST"
  - "D3 MODEL SELECT"
  - "D4 GAS OPTION"
  - "D5 SEALING TIME"
  - "D6 COOLING TIME"
  - "D7 OFFSET CALIB"
  - "D8 VACUUM SENSOR"
  - "D9 SIPROMAC PUB"
  - "D10 LOADING TIME" (automatic units only)
  - "D11 UNLOADNG TIME" (automatic units only)
  - "SYSTEM MONITOR" (no access code required)
  - "SOFTWARE: R x.xx"
  - "WORK HRS: xxxxx"
  - "CYCLES: xxxxxxxx"

# -KEYBOARD DETAILS-

## MC-40 CONTROLS

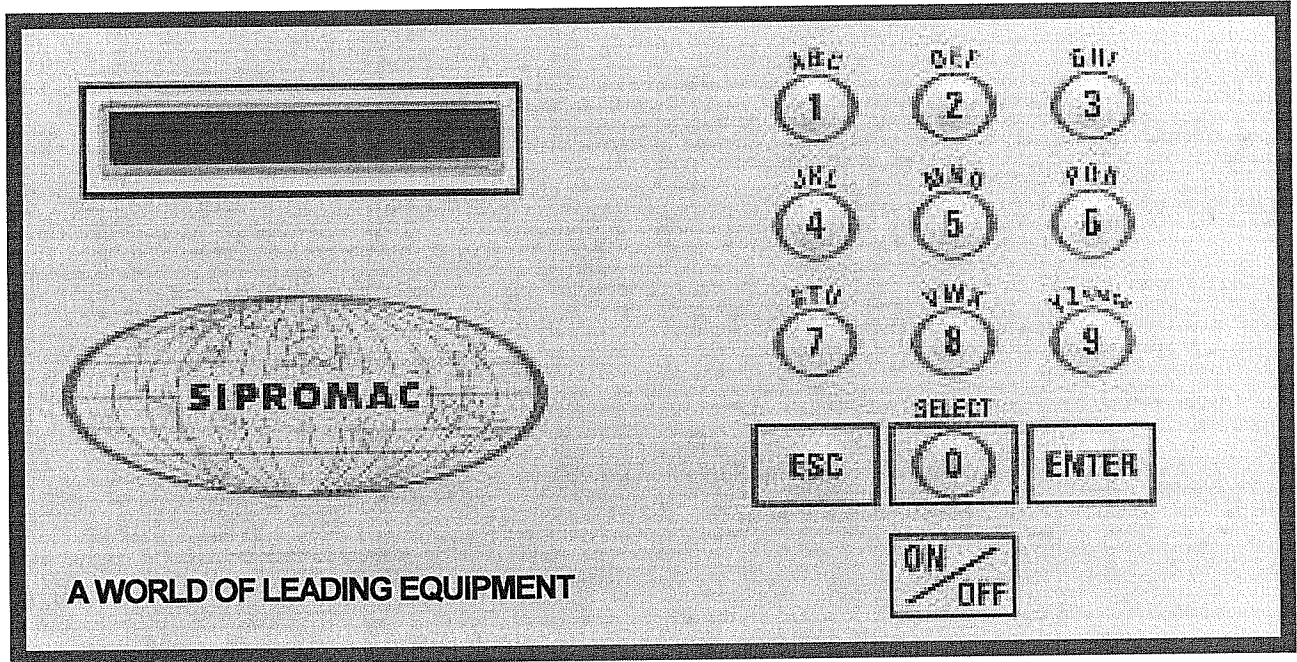



**WARNING: All electrical work described in this brochure should be done by a QUALIFIED and AUTHORIZED technician.**

### **3.4 Daily cleaning:**

For hygienic cleanliness, it is imperative to clean chamber and spacers daily. Also clean the lid rubber to assure tight seat of the lid.

**Cleaning instructions for gas injection nozzles:** Periodically on a regular basis the gas injection nozzles must be removed with the connection tube and soaked in a food grade soap and water solution, then dried and re-installed.

## **4. TROUBLE SHOOTING:**

### **4.1 Failure during packaging cycle:**

#### **4.1.1 "VACUUM ERROR" message is displayed on LCD:**

No pressure variation is picked up by the PCB transducer during the vacuum sequence within a preset period of time.

- Check vacuum lines for potential leaks or kinks.

#### **4.1.2 "GAS FLUSH ERROR" message is displayed on LCD:**

No pressure variation is picked up by the PCB transducer during the gas flush sequence within a preset period of time.

- Check gas flush and vacuum lines for potential leaks or kinks.

#### **4.1.3 "ATMOSPHERE ERROR" message is displayed on LCD:**

No pressure variation is picked up by the PCB transducer during the atmosphere sequence within a preset period of time.

- Check vacuum lines for potential leaks or kinks.

#### **4.1.4 "COVER DOWN ERROR" message is displayed on LCD(manual units):**

The input signal of the down position switch has been lost during cycle execution.

- Check limit switch adjustment.

## **4.2 Insufficient vacuum:**

### **4.2.1 Leakage in the bag:**

Most frequently, insufficient vacuum in bags is due to leakage in bag and not due to any fault of the machine.

Pin-hole leak for which there is no obvious explanation is due to faulty bag material.

Pin-hole leak caused by sharp edge of the product (bone, etc.). Use bone-guard or thicker film.

Tear in bag by careless handling (sharp edge on filling table, damage made by retailer or customer).

Leakage in lateral or bottom seal, complain to supplier of bags or film.

### **4.2.2 No leakage in the bag:**

Bag is too large, therefore the surplus of air remains visible (there is surplus of air in 0.4% of the bag volume in each bag). Use bags of suitable size.

Vacuum level is too low:

Pressure bar is jammed and closes opening of bag during evacuation.

### **4.2.3 Insufficient vacuum in chamber:**

If troubles described under 4.2.1 and 4.2.2 do not apply, there is something wrong with the evacuation. To find the leakage quickly, check for leaks with a precision vacuumeter, going back step by step from the chamber to the pump.

At the chamber (measuring point at base of valve) at maximum time of evacuation. If more than 6 torr, proceed directly to the pump, if more than 3 torr: have pump service by pump supplier. If pressure at pump is good, reconnect hoses to pump and measure again.

Verify at vacuum hose connections and valve connections.

When proceeding this way, starting from pump, loss of pressure per step must not exceed 0.5 to 1 torr.

**Caution:** Verify connections of measuring equipment before verifying machine.

Most frequent points of leakage: lid gasket, damaged vacuum hose or loose hose clamps.



#### **4.3 Faulty seal:**

##### **4.3.1 Insufficient seal:**

Damaged teflon or silicone rubber.

Sealing pressure too low, bellows leaking or pressure bar jammed.

Leakers in seal: heating wire mechanically damaged (knicked) or silicone rubber uneven.

##### **4.3.2 No seal:**

Sealing wire burnt.

Faulty contact in sealing circuit.

Sealing transformer burnt through.

Contactors does not work.

##### **4.3.3 Permanent sealing current:**

Contactors is jammed check sealing transformer for damage through overload.

##### **4.3.4 Seal does not stick:**

Insufficient layer of polyethylene (inferior quality of bags).

Seal area extremely contaminated by fat or meat juice. Use filling aid.

Sealing temperature is too low (when using very thick films).

**Caution:** Do not increase sealing time more than really necessary; higher temperature will reduce working life of teflon and silicone rubber.

#### **4.4 Fault in the valve:**

Vacuum or air valve does not open.

Check whether there is voltage on the magnetic valves during their period of operation. If there is no voltage a wire is broken or the PC board is damaged.

Lid does not open at the end of the cycle; air enters, but there is still 20 - 40% vacuum in chamber. Vacuum valve does not close.



#### **4.5 MC40 Control board failure**

**NOTE:** Refer to menu structure on page 14.

This board software is allowing access to a "Diagnostics Menu". Only qualified service technicians are authorized to access this menu by entering a security password.

By accessing either the "D1 input test" feature or the "D2 output test" feature, a trained technician will be able to quickly know the origin of the problem: pump, sealing system, pneumatic problem, security switches problem, etc...

Keep in mind that in most cases trouble is due to a leakage, loose electrical connection or evident damage to the main components: vacuum pump, valves, electrical contactors, thermal overload, fuses holder or transformer.

For assistance do not hesitate to contact your local service technicians.

#### **5. Regular maintenance:**

Routine controls to be made at regular intervals:

Check teflon for wear.

Check silicone rubber for burnt spots and smooth even position.

Check pressure bar for jamming.

Check lid sealing for damage and hardened spots.

Check switch-point of micro switch, adjust if necessary.

Check evacuation hose for damage (contraction of diameter, or abrasions).

Check vacuum connections for tightness.

Check oil in pump (oil level in view glass; add if necessary. Regular change of oil - necessity indicated by change of color).

Check vacuum in chamber with precision vacuumeter.

Check function of cycle with various settings of timers.

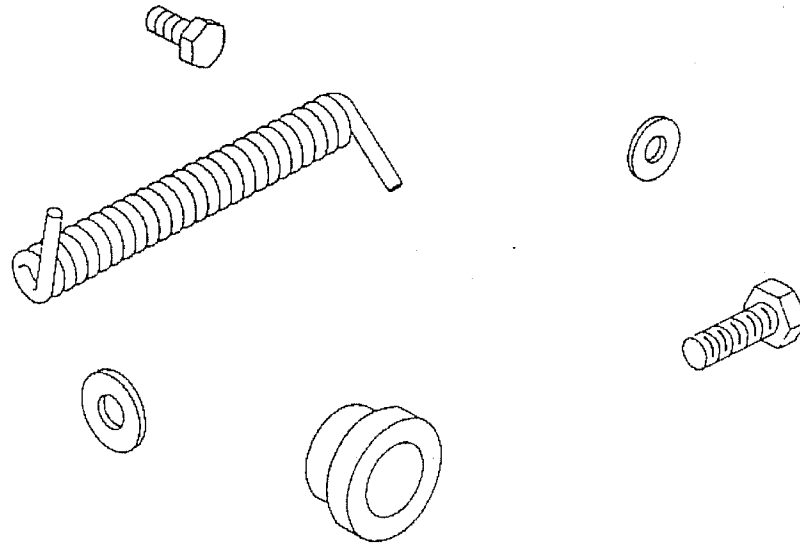

# MECHANICAL DRAWING

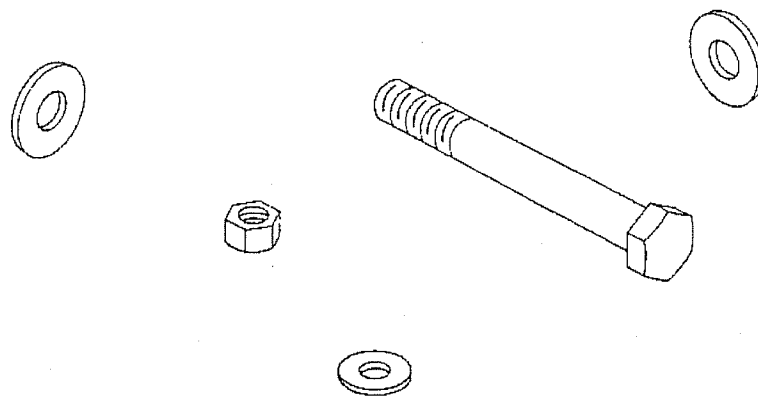

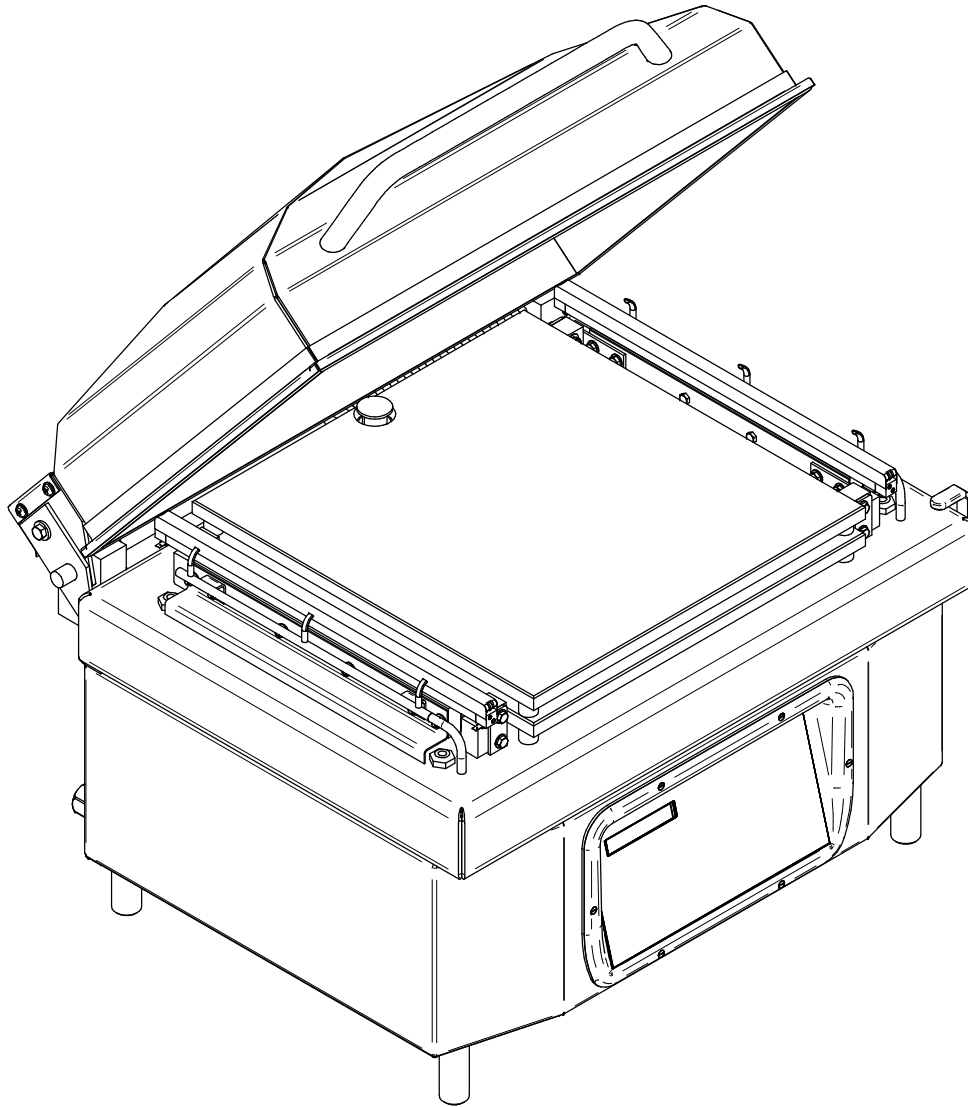

ITEM	PART #	DESCRIPTION	QT.
1	001-1335	COVER STOPPER	1
2	001A1457	REAR PANEL	1
3	004-0129	COVER AXIS PRE-ASS'Y	1
4	004-0172	SPRING COVER PRE-ASSEMBLY	1
5	004B4113	GAS VALVE ASSEMBLY (OPTION)	1
6	005-0444	COVER ASSEMBLY	1
7	005A0533	LEFT GAS INJECTION BAR ASSEMBLY	1
8	005A0564	SEAL BAR ASSEMBLY W/SUPPORT (TWIN SEAL)	2
9	005A0565	SEAL BAR ASSEMBLY W/SUPPORT (BAG CUT)	2
10	005A0603	BASE MACHINE ASSEMBLY	1
11	005A0808	RIGHT GAS INJECTION BAR ASSEMBLY	1
12	005A1496	AIR REGULATOR VALVE ASSY	1
13	005A1504	ELECTRONIC SOFT AIR (KB-0020)	1
14	005A1512	KB-0020 PUMP ASSEMBLY	1
15	005B0583	MC-40 CONTROL BOARD	1
16	008-0358	COVER SPRING	1
17	033-0013	MC-40 KEYBOARD "CPI/GUARDIAN"	1
18	033-0014	MC-40 KEYBOARD "FOODPAK"	1
19	033-0015	MC-40 KEYBOARD "SIPROMAC"	1
20	033-0016	MC-40 KEYBOARD "HOLLYMATIC"	1
21	033-0018	MC-40 KEYBOARD "BERKEL"	1
22	033-0019	MC-40 KEYBOARD "BSA"	1
23	033-0021	MC-40 KEYBOARD "SUPPLY ONE"	1
24	051-0185	SCREW 1/4-20x 1/2" PAN PHIL S/S	8
25	051-0360	BOLT 3/8"-16nc. X 1" S/S	2
26	051-0620	NUT 3/8"-16 NC S/S	2
27	051-0740	WASHER 1/4" FLAT S/S	8
28	051-0783	WASHER 3/8" FLAT THICK S/S	2
29	100-0832	HEX. PLUG 1/2" NPT S/S	1
30	102-0330	ELBOW 1/4" NPT X 3/8" HOSE QUICK	1
31	104-0064	SILICONE TUBING 3/8" OD x 3/16" ID x 82MM	1
32	104-0064	SILICONE TUBING 3/8" OD x 3/16" ID x 82MM	1
33	114-2050	EXHAUST MUFFLER 1/2 NPT S/S	1
34	127-0040	STICKER "AIR" BLUE/WHITE 1" X 2"	1
35	127-0041	STICKER "GAS" YELLOW/BLACK 1" X 2"	1

LET.	MODIFICATION	DATE	INT.
------	--------------	------	------

MACHINE		<b>450T</b>		DEPT. TOL.	METRIC	INCH	SIPROMAC ST-GERMAIN DE GRANTHAM QUEBEC CANADA
PART		MACHINE ASSEMBLY		USINAGE	± 0.1	± 0.004"	
ITEM		CNC		TOLERIE	± 0.5	± 0.020"	
MAT.		3D DWG BY <b>SBU</b>		DATE	14-06-19		NO. <b>005B0924</b>
		2D DWG BY <b>AG</b>		DATE	14-06-25		
				N.T.S.		DEPT.	M
						QTY.	1

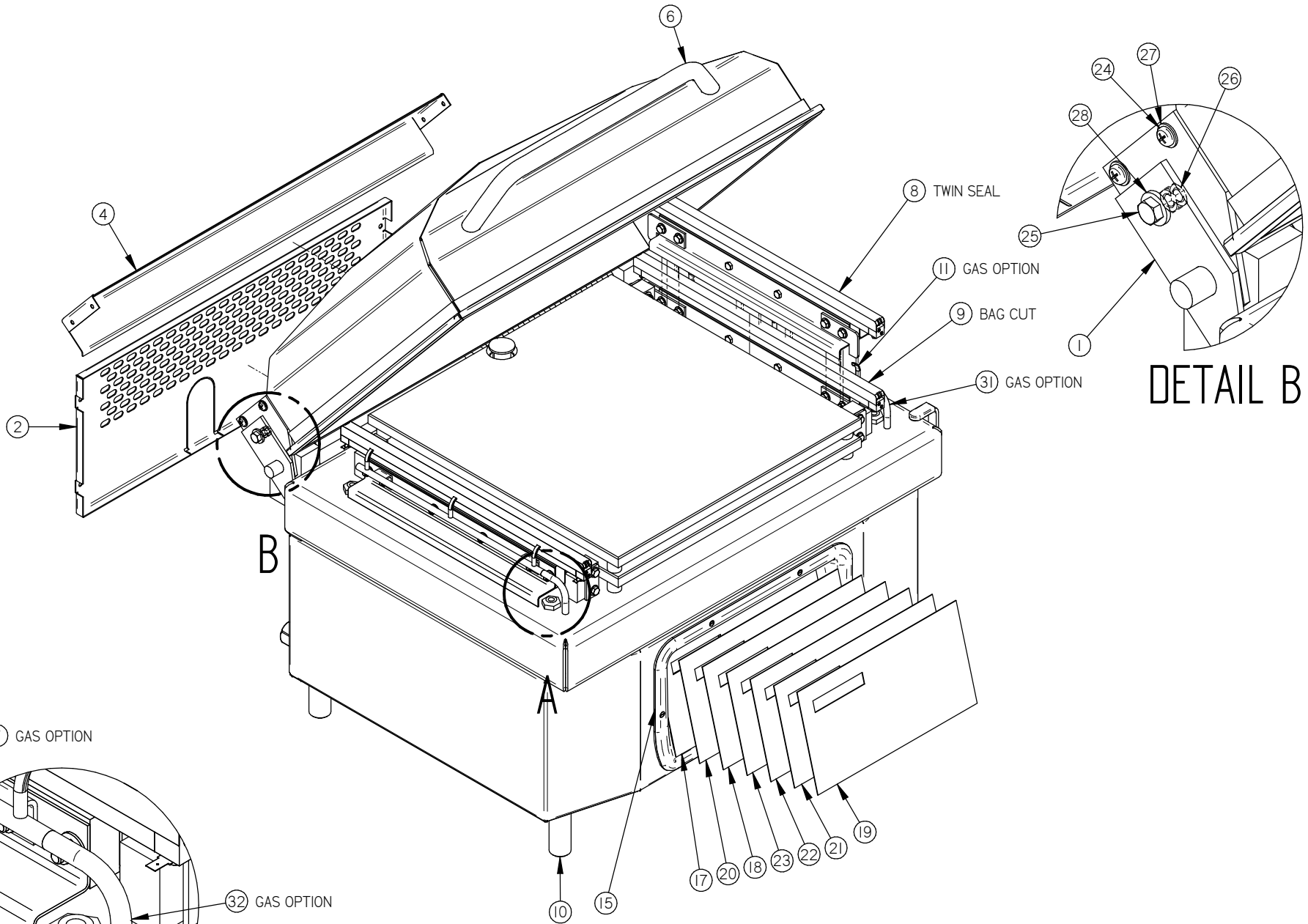

DETAIL B

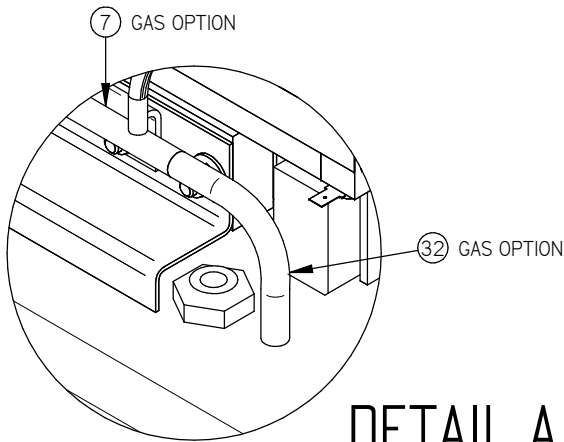

DETAIL A

MACHINE		<b>450T</b>		DEPT. TOL.	METRIC	INCH	SIPROMAC ST-GERMAIN DE GRANTHAM QUEBEC CANADA
PART		<b>MACHINE ASSEMBLY</b>		USINAGE	± 0.1	± 0.004"	
ITEM				TOLERIE	± 0.5	± 0.020"	
MAT.				SOUDAGE	± 0.5	± 0.020"	N.T.S.
3D DWG BY		SBU		DATE		14-06-19	NO. <b>005B0924</b>
2D DWG BY				DATE			DEPT. <b>M</b> QTY. <b>1</b>

COVER INSTALLATION PROCEDURE

1. ENSURE THAT THE ALUMINIUM BLOCKS ARE FREE
2. PLACE THE COVER ON THE MACHINE
3. PLACE THE SHAFT IN PLACE
4. DO THE VACCUM
5. AJUST THE ALUMINIUM BLOCKS
6. ENSURE THAT THE SHAFT CAN ROTATE FREELY
7. RESTORE THE ATMOSPHERIC PRESSURE
8. INSTALL THE SPRING

ÉTAPE D'INSTALLATION DU COUVERCLE

1. S'ASSURER QUE LES BLOCS D'ALUMINIUM SONT LOUSSES
2. METTRE LE COUVERCLE SUR LA MACHINE
3. METTRE L'ARBRE EN PLACE
4. FAIRE LE VIDE DE LA MACHINE
5. AJUSTER LES BLOCS D'ALUMINIUM
6. S'ASSURER QUE L'ARBRE TOURNE LIBREMENT
7. RETABLIR LA PRESSION ATMOSPHERIQUE
8. INSTALLER LE RESSORT

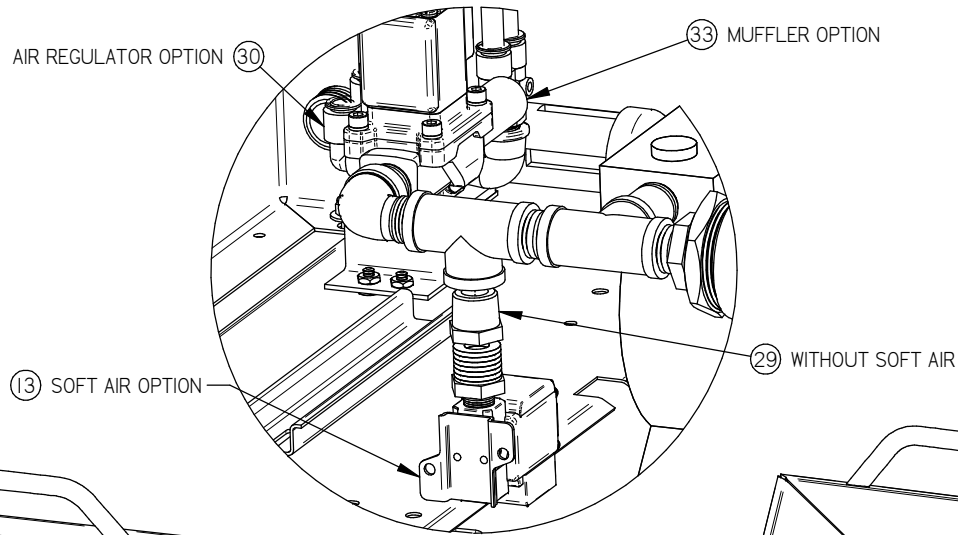

DETAIL C

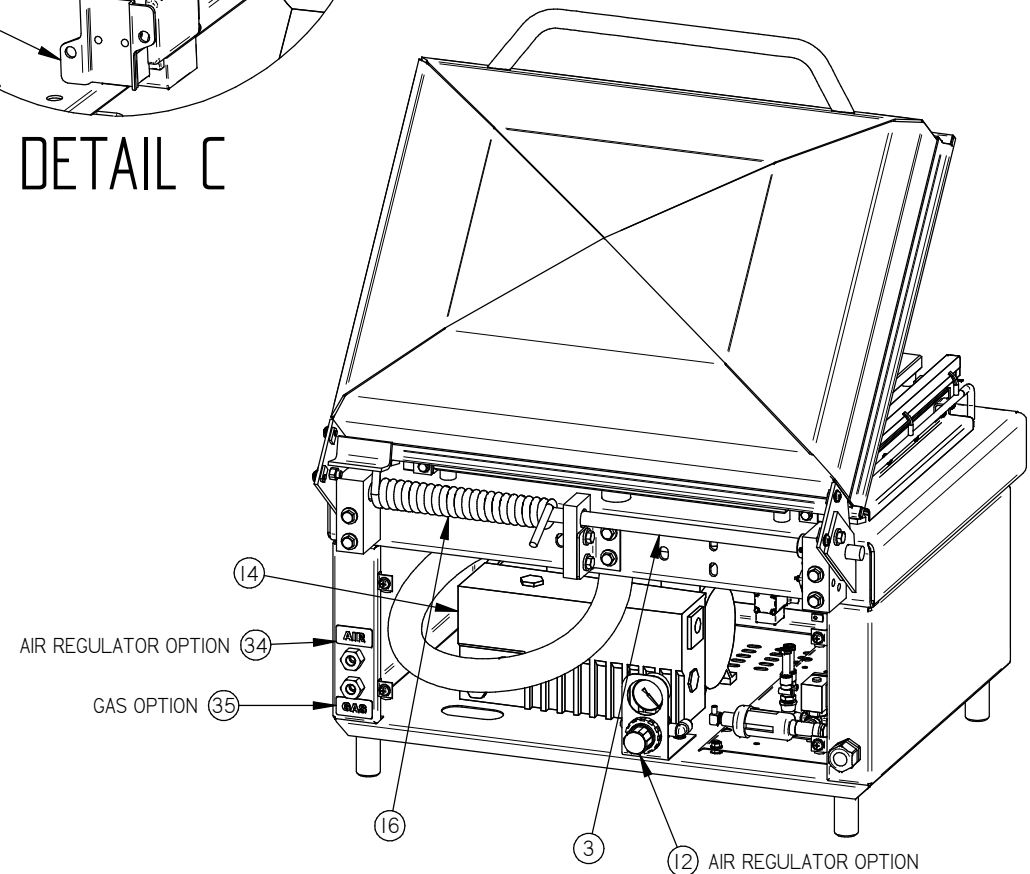
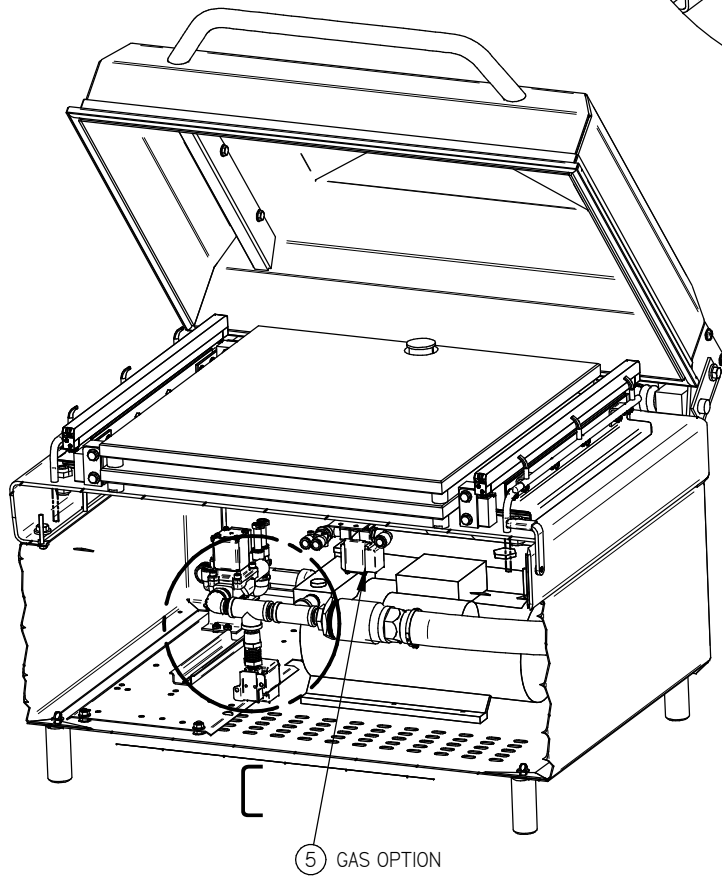

MACHINE		<b>450T</b>		DEPT. TOL. METRIC	INCH	SIPROMAC ST-GERMAIN DE GRANTHAM QUEBEC CANADA
PART		<b>MACHINE ASSEMBLY</b>		USINAGE	± 0.1 ± 0.004"	
ITEM		CNC		TOLERIE	± 0.5 ± 0.020"	
MAT.		3D DWG BY <b>SBU</b>		DATE	<b>14-06-19</b>	N.T.S.
		2D DWG BY		DATE		
				DEPT.	<b>M</b>	QTY. <b>1</b>
						<b>005B0924</b>

# 005A0603

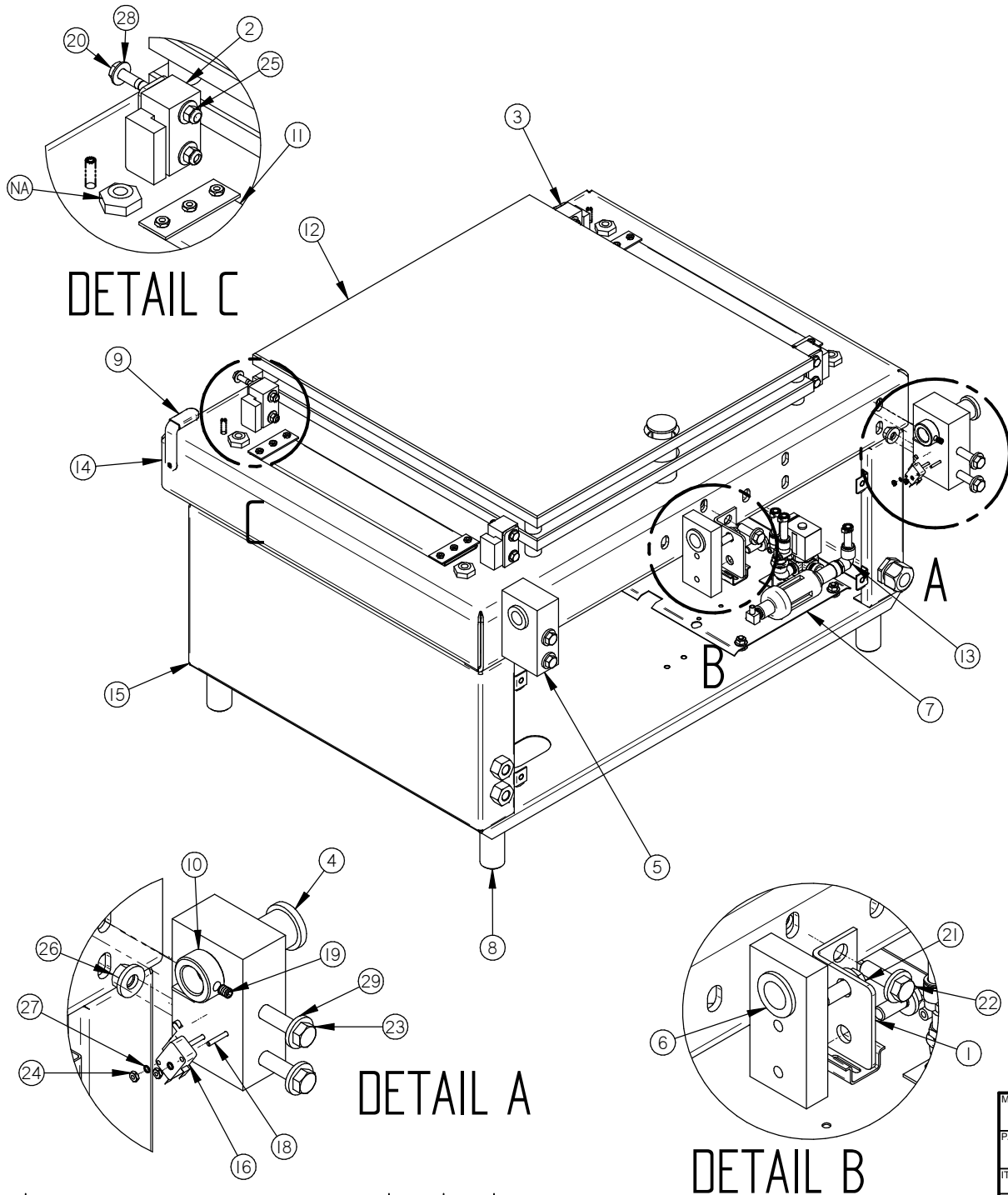

ITEM	PART #	DESCRIPTION	QT.
1	001-1540	CENTRAL COVER AXIS SUPPORT FIXATION	1
2	002-0326	LEFT SEAL BAR GUIDE BLOCK	2
3	002-0327	RIGHT SEAL BAR GUIDE BLOCK	2
4	004-0274	LEFT COVER AXIS SUPPORT	1
5	004-0275	RIGHT COVER AXIS SUPPORT	1
6	004-0276	CENTRAL COVR AXIS SUPPORT	1
7	004A0042	ELEC. SUPPORT PRE-ASS'Y	1
8	004A4112	NSF FOOT	4
9	004B1651	COVER HOLD DOWN ASS'Y	1
10	005-0348	MICRO SWITCH COLLAR ASS'Y	1
11	005-0532	BELLOWS ASSEMBLY	2
12	005-0534	FILLER PLATE ASSEMBLY	2
13	005A1513	BELLOWS VALVE ASSY	1
14	005C0531	TABLE ASSEMBLY	1
15	005D0604	STRUCTURE ASSEMBLY	1
16	026-0610	LIMIT SWITCH LONG ROLLER	1
17	036-0400	WIRE CONNECT. 3/8" NPT CD09/O-RING/NUT	4
18	051-0094	SCREW 4-40 X 1 1/2" FLAT SLOT SS	2
19	051-0178	SCREW 1/4"-20 x 5/16" SKT SET S/S	1
20	051-0250	BOLT 1/4"-20nc. X 1 1/2" S/S	8
21	051-0360	BOLT 3/8"-16nc. X 1" S/S	6
22	051-0372	BOLT 3/8"-16 x 1-1/4" S/S	2
23	051-0424	BOLT 3/8"-16 x 3-1/2" SS	4
24	051-0540	NUT #4-40 HEX S/S	2
25	051-0581	NUT 1/4"-20 NYLON LOCK S/S	8
26	051-0620	NUT 3/8"-16 NC S/S	10
27	051-0715	WASHER #4 LOCK SS	2
28	051-0740	WASHER 1/4" FLAT S/S	16
29	051-0783	WASHER 3/8" FLAT THICK S/S	22

LET.	MODIFICATION	DATE	INT.
------	--------------	------	------

MACHINE		<b>450A</b>		DEPT. TOL.	METRIC	INCH	SIPROMAC ST-GERMAIN DE GRANTHAM QUEBEC CANADA
PART		<b>BASE MACHINE ASSEMBLY</b>		USINAGE	± 0.1	± 0.004"	
ITEM		CNC		TOLERIE	± 0.5	± 0.020"	
MAT.		3D DWG BY <b>SBU</b>		DATE	<b>14-06-09</b>		NO. <b>005A0603</b>
		2D DWG BY <b>AG</b>		DATE	<b>14-06-23</b>		
				DEPT.	<b>M</b>		QTY. <b>1</b>

# 004A0351

ITEM	PART #	DESCRIPTION	QT.
1	002A0480	UPPER SEAL BAR SUPPORT	1
2	008-0450	UPPER SEAL BAR RUBBER	1

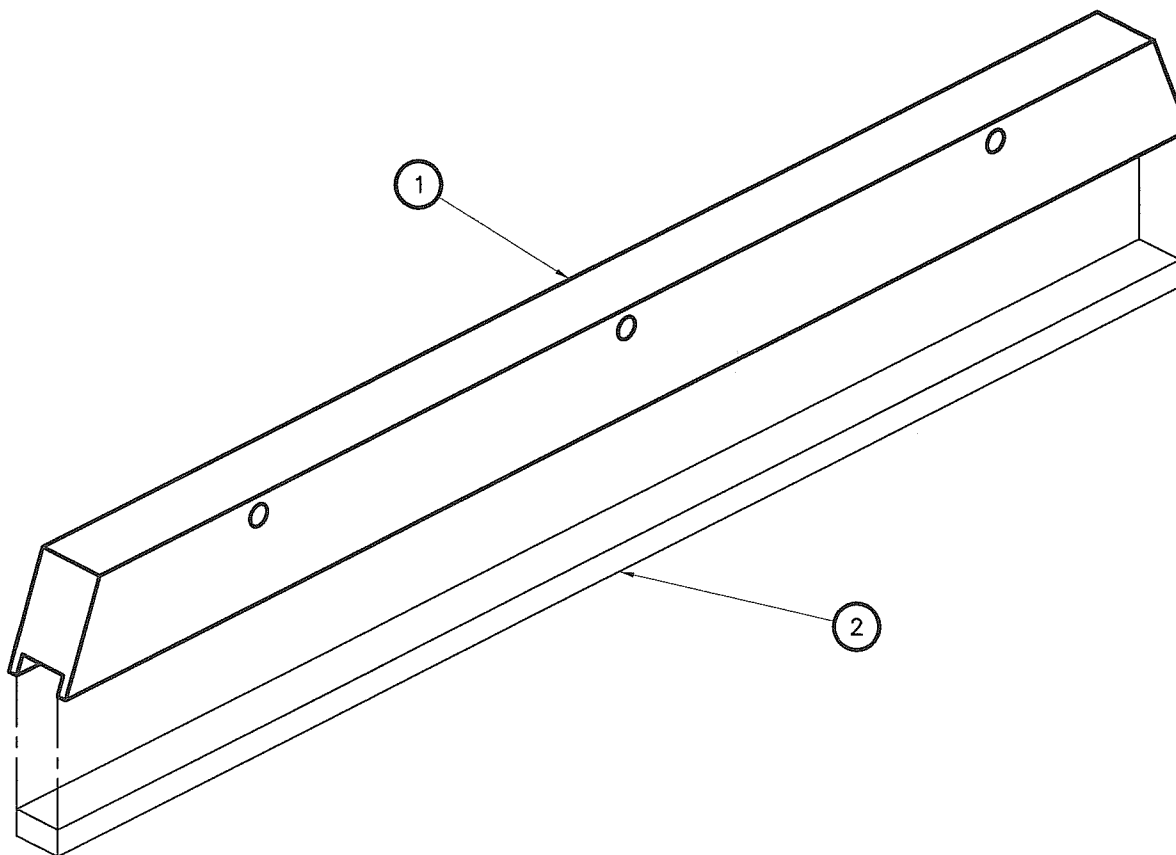

D	ADDED 450T WAS 004A0161	08-05-26	D.A.
C	REDRAWN	99-08-02	S.L.
LET.	MODIFICATION	DATE	INT.

MACHINE	400, 450T & 450A	METRIC TOLERANCE	INCH TOLERANCE	SIPROMAC
PART	UPPER SEAL BAR PRE-ASS'Y	0. ± .5 .0 ± .05 .00 ± .005 .000 ± .0005 ANGLE ± 1°	.0 ± .015" .00 ± .005" .000 ± .0005" N.T.S.	ST-GERMAIN DE GRANTHAM QUEBEC CANADA
ITEM:	CNC: -----	DEPT.	M-1	QT. 2
MAT:	BY S. LAROUCHE	DATE	99-08-02	NO. 004A0351
	APP.	DATE	9-12-15	

# 005A0565

ITEM	PART #	DESCRIPTION	QT.
1	004-0355	BAG CUT SEAL BAR PRE-ASSEMBLY	1
2	002-0512	SEAL BAR SUPPORT	1
3	051-0256	BOLT 1/4"-20nc. X 1 3/4" CAP SKT S/S	3
4	001-1960	EXTERIOR BELLOWS COVER	1
5	001-1856	EXTERIOR BELLOWS COVER	1
6	001-1858	SEAL BAR GUIDE	2
7	051-0740	WASHER 1/4" FLAT S/S	10
8	051-0250	BOLT 1/4"-20nc. X 1 1/2" S/S	4
9	051-0581	NUT 1/4"-20 NYLON LOCK S/S	6
10	051-0230	HEX BOLT 1/4-20 x 1 1/4" SS	2

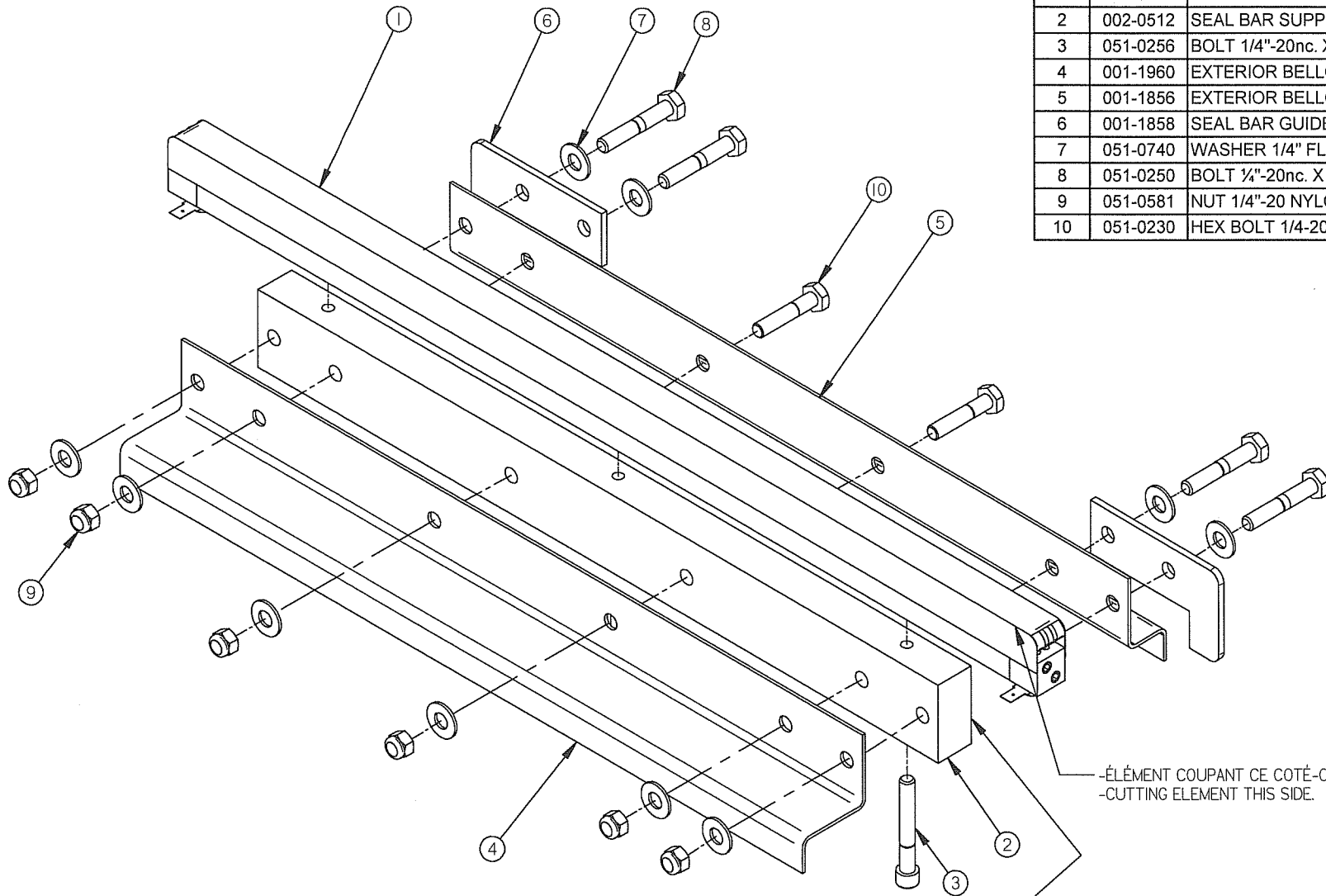

-ÉLÉMENT COUPANT CE CÔTÉ-CI.  
-CUTTING ELEMENT THIS SIDE.

-CE CÔTÉ DU SUPPORT ÉGAL AVEC DE LA BARRE DE SCELLAGE.  
-THIS SIDE OF SUPPORT TO FIT FLUSH W/ SEAL BAR.

-ITEM #2 ÉGAL AVEC L'ITEM #4 & #5.  
-ITEM #2 FLUSH WITH ITEM #4 & #5.

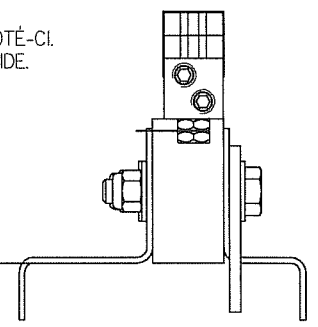

**-END VIEW-**

**-BAG CUT OPTION-**

MACHINE <b>400, 450T &amp; 450A</b>		DEPT TOL METRIC INCH	SIPROMAC ST-GERMAIN DE GRANTHAM QUEBEC CANADA
PART <b>SEAL BAR ASSEMBLY W/SUPPORT</b>		USINAGE ± 0.1 ± 0.004" TOLERIE ± 0.5 ± 0.020" SOUDAGE ± 0.5 ± 0.020"	
ITEM _____		N.T.S.	
MAT. _____	CNC _____	DEPT. <b>M-I-(M)</b>	QTY. <b>2</b>
DWG BY <b>CF</b>	DATE <b>12-04-03</b>	NO. <b>005A0565</b>	
APP. BY _____	DATE _____		

D	REDRAWN/ REMOVED WIRE DUCT	12-04-03	CF
LET.	MODIFICATION	DATE	INT.

1005A0564

ITEM	PART #	DESCRIPTION	QT.
1	004-0352	SEAL BAR PRE-ASSEMBLY	1
2	002-0512	SEAL BAR SUPPORT	1
3	051-0256	BOLT 1/4"-20nc. X 1 3/4" CAP SKT S/S	3
4	001-1960	EXTERIOR BELLOWS COVER	1
5	001-1856	EXTERIOR BELLOWS COVER	1
6	001-1858	SEAL BAR GUIDE	2
7	051-0740	WASHER 1/4" FLAT S/S	10
8	051-0250	BOLT 1/4"-20nc. X 1 1/2" S/S	4
9	051-0581	NUT 1/4"-20 NYLON LOCK S/S	6
10	051-0230	HEX BOLT 1/4-20 x 1 1/4" SS	2

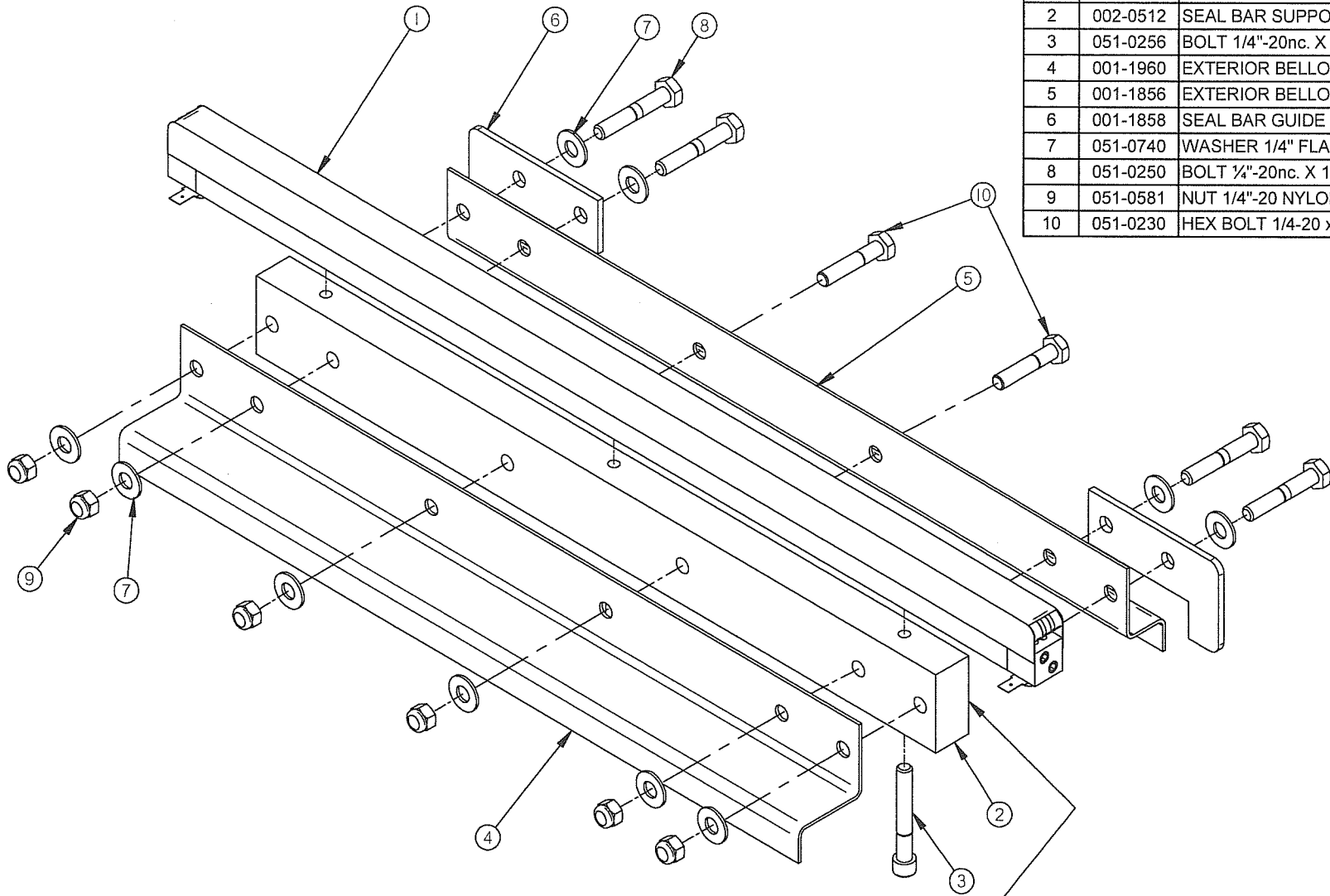

-CE COTÉ DU SUPPORT ÉGAL AVEC DE LA BARRE DE SCELLAGE.  
-THIS SIDE OF SUPPORT TO FIT FLUSH W/ SEAL BAR.

-ITEM #2 ÉGAL AVEC L'ITEM #4 & #5.  
-ITEM #2 FLUSH WITH ITEM #4 & #5.

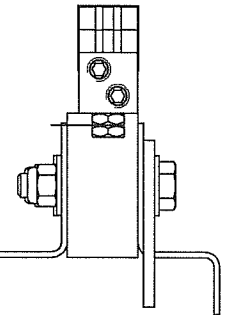

-TWIN SEAL OPTION-

-END VIEW-

MACHINE <b>400, 450T &amp; 450A</b>		DEPT. TOL. METRIC	INCH	SIPROMAC ST-GERMAIN DE GRANTHAM QUEBEC CANADA
PART <b>SEAL BAR ASSEMBLY W/SUPPORT</b>		USINAGE ± 0.1	± 0.004	
		TOLERIE ± 0.5	± 0.020"	
		SOUDEGE ± 0.5	± 0.020"	
ITEM	CNC	N.T.S.		
MAT.	DWG BY <b>CF</b>	DATE <b>12-04-03</b>	NO	DEPT. <b>M-I(M)</b> QTY. <b>2</b>
	APP. BY	DATE	<b>005A0564</b>	

E	REDRAWN/ REMOVE WIRE DUCT	12-04-03	CF
LET.	MODIFICATION	DATE	INT.

1004-0355

ITEM	#PART	DESCRIPTION	QT.
1	002-0481	SEAL BAR	1
2	002-0031	CONNECTOR	2
3	039-0230	REFLEX BAND 2.5MM (626mm EA.)	0.063
4	039-0270	"T" PROFILE CUT. ELEM. (626mm EA.)	0.063
5	052-0395	SCREW 1/4"-20 NC. X 5/16" SET HEX SKT OVAL PT	4
6	052-0250	SCREW #8-32 X 1 1/2" RND SLOT BRASS	2
7	051-0550	NUT #8-32 S/S	4
8	176-0200	TEFLON TAPE 5S ADHESIVE X 2" X (496mm EA.)	0.063
9	027-0400	CONNECTOR ADAPTOR 1/4" X #10 STUD	2

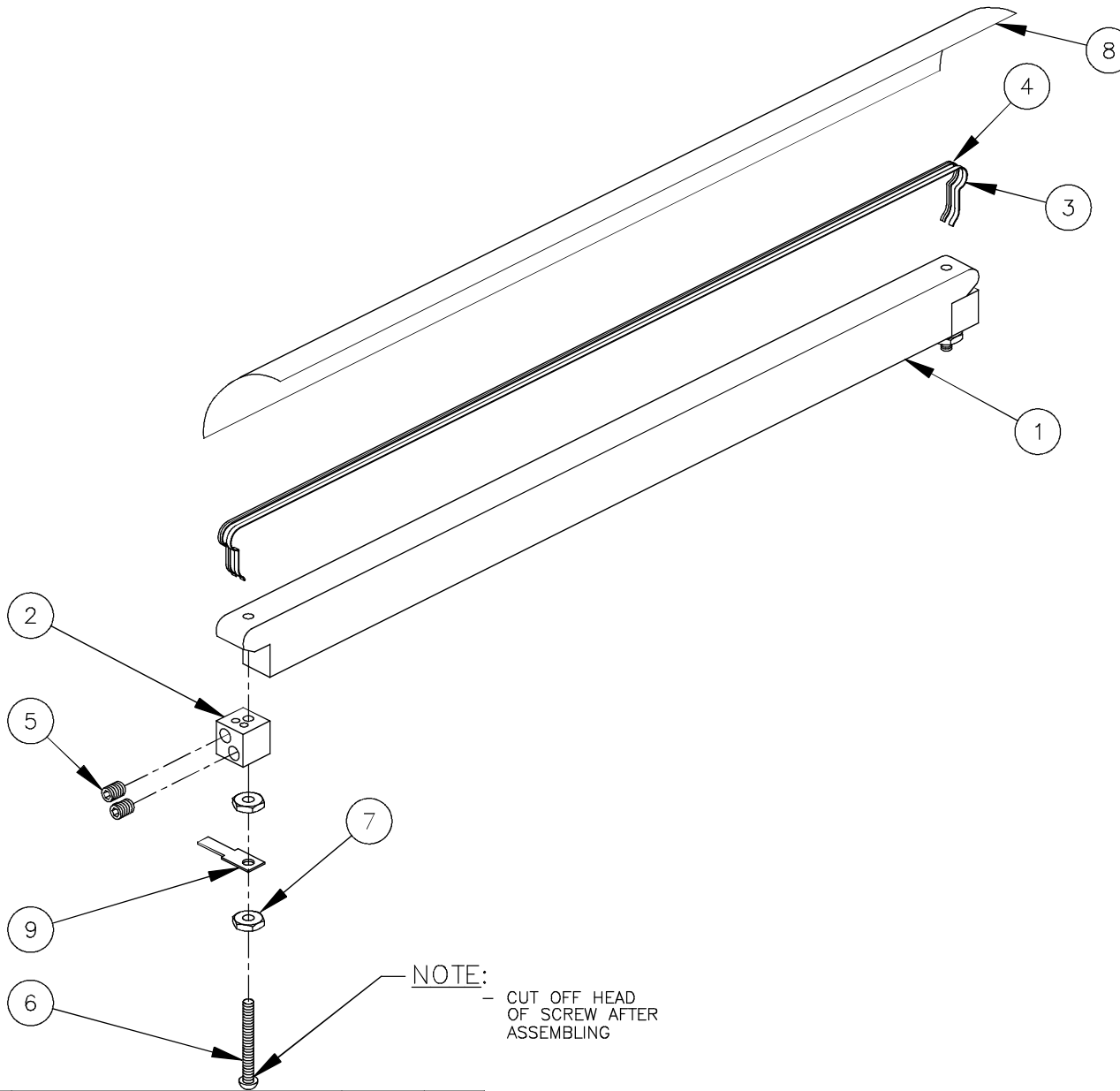

NOTE: - CUT OFF HEAD OF SCREW AFTER ASSEMBLING

420A	4
450T	2
450A	2
400	2
350D	2
350	1
300D	2
300	1
MACHINE	QTÉ.

-BAG CUT OPTION-

G	ADDED 420A WAS 005-0267	14-08-21	SBU
F	ADDED 300, 300D, 350 & 350D WAS 005-0267	12-09-24	J.G.
E	ADDED 450T WAS 005-0383	08-05-26	D.A.
D	MODIFICATION #A-0398 (CONNECTEUR)	04-04-19	J.G.
C	ADDED 400	99-05-06	S.L.
B	REDRAWN	98-02-10	A.P.
LET.	MODIFICATION	DATE	INT.

MACHINE	VOIR LISTE		<table border="1"> <thead> <tr> <th colspan="2">TOLERANCE</th> <th>INCH</th> </tr> </thead> <tbody> <tr> <td>USINAGE</td> <td>± 0.1</td> <td>± 0.004"</td> </tr> <tr> <td>TOLERIE</td> <td>± 0.5</td> <td>± 0.020"</td> </tr> <tr> <td>SOUDAGE</td> <td>± 0.5</td> <td>± 0.020"</td> </tr> </tbody> </table>		TOLERANCE		INCH	USINAGE	± 0.1	± 0.004"	TOLERIE	± 0.5	± 0.020"	SOUDAGE	± 0.5	± 0.020"	SIPROMAC	
TOLERANCE		INCH																
USINAGE	± 0.1	± 0.004"																
TOLERIE	± 0.5	± 0.020"																
SOUDAGE	± 0.5	± 0.020"																
PART	SEAL BAR PRE-ASSEMBLY		N.T.S.		ST-GERMAIN DE GRANTHAM, QUEBEC CANADA													
ITEM:	CNC:		M-I		QT. LISTE													
MAT:	DWG BY APP.	A.P.	DATE 98-02-10	NO.	004-0355													

1004-0352

ITEM	#PART	DESCRIPTION	QT.
1	002-0481	SEAL BAR (TABLE)	1
2	002-0031	CONNECTOR	2
3	039-0200	SEALING ELEM. STD TWIN (2x626mm EA.)	4.31
4	052-0395	SCREW 1/4"-20 NC. X 5/16" SET HEX SKT OVAL PT	4
5	052-0250	SCREW #8-32 X 1 1/2" RND SLOT BRASS	2
6	051-0550	NUT #8-32 S/S	4
7	176-0200	TEFLON TAPE 5S ADHESIVE X 2" X (496mm EA.)	0.063
8	027-0400	CONNECTOR ADAPTOR 1/4" X #10 STUD	2

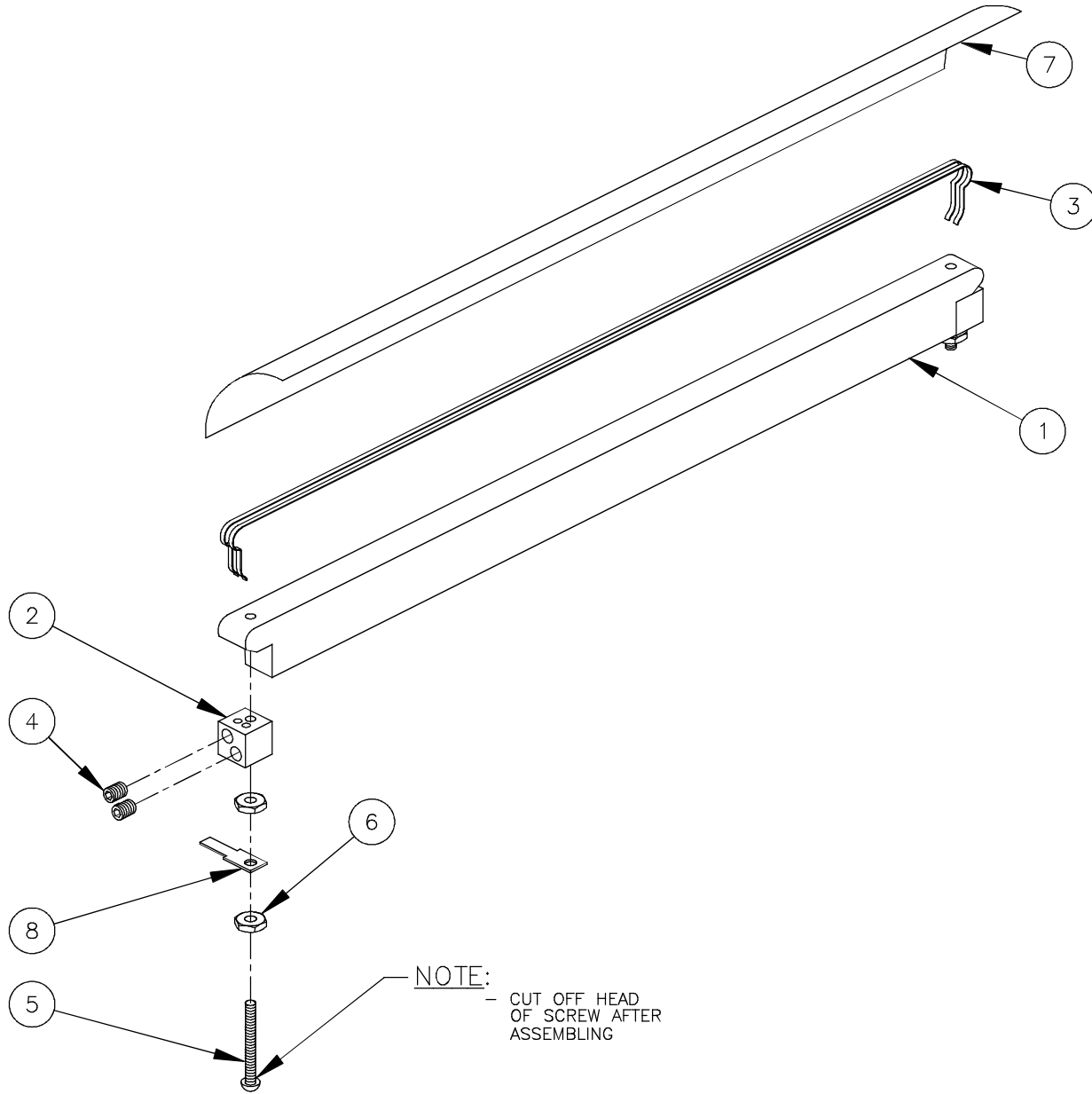

420A	4
450T	2
450A	2
400	2
350D	2
350	1
300D	2
300	1
MACHINE	QTÉ.

G	ADDED 420A WAS 005-0267	14-08-21	SBU
F	ADDED 300, 300D, 350 & 350D WAS 005-0267	12-09-24	J.G.
E	ADDED 450T WAS 005-0377	08-05-26	D.A.
D	MODIFICATION #A-0398 (CONNECTEUR)	04-04-19	J.G.
C	ADDED 400	99-05-06	S.L.
B	REDRAWN	98-02-10	A.P.
LET.	MODIFICATION	DATE	INT.

MACHINE		TOLERANCE		SIPROMAC ST-GERMAIN DE GRANTHAM, QUEBEC CANADA
PART		METRIC	INCH	
VOIR LISTE		USINAGE ± 0.1	± 0.004"	
SEAL BAR PRE-ASSEMBLY		TOLERIE ± 0.5	± 0.020"	
ITEM: _____		SOUDAGE ± 0.5	± 0.020"	
MAT: _____		N.T.S.		DEPT. M-1
DWC BY A. P.		DATE 98-02-10	NO. 004-0352	QT. 2
APP. _____		DATE _____		

# 005-0444

ITEM	PART #	DESCRIPTION	QT.
1	004-0162	COVER PRE-ASSEMBLY	1
2	179-0020	NEOPRENE SPONGE 1/2" x 16'	1
3	004A0351	UPPER SEAL BAR PRE-ASSY	2
4	051-0740	WASHER 1/4" FLAT S/S	12
5	051-0255	BOLT 1/4-20 x 1-3/4" HEX SS	6
6	051-0581	NUT 1/4"-20 NYLON LOCK S/S	6

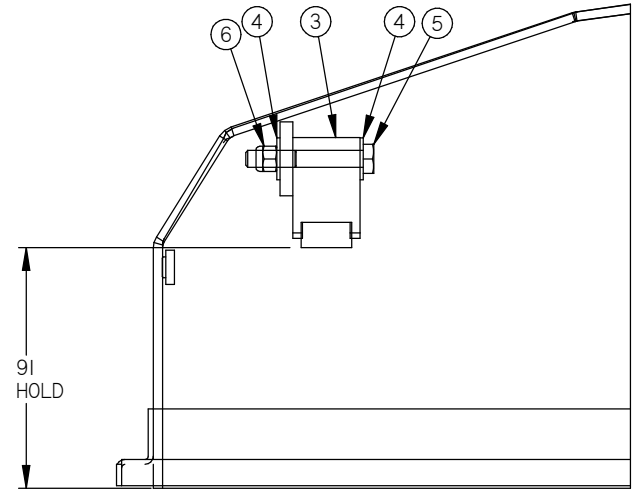
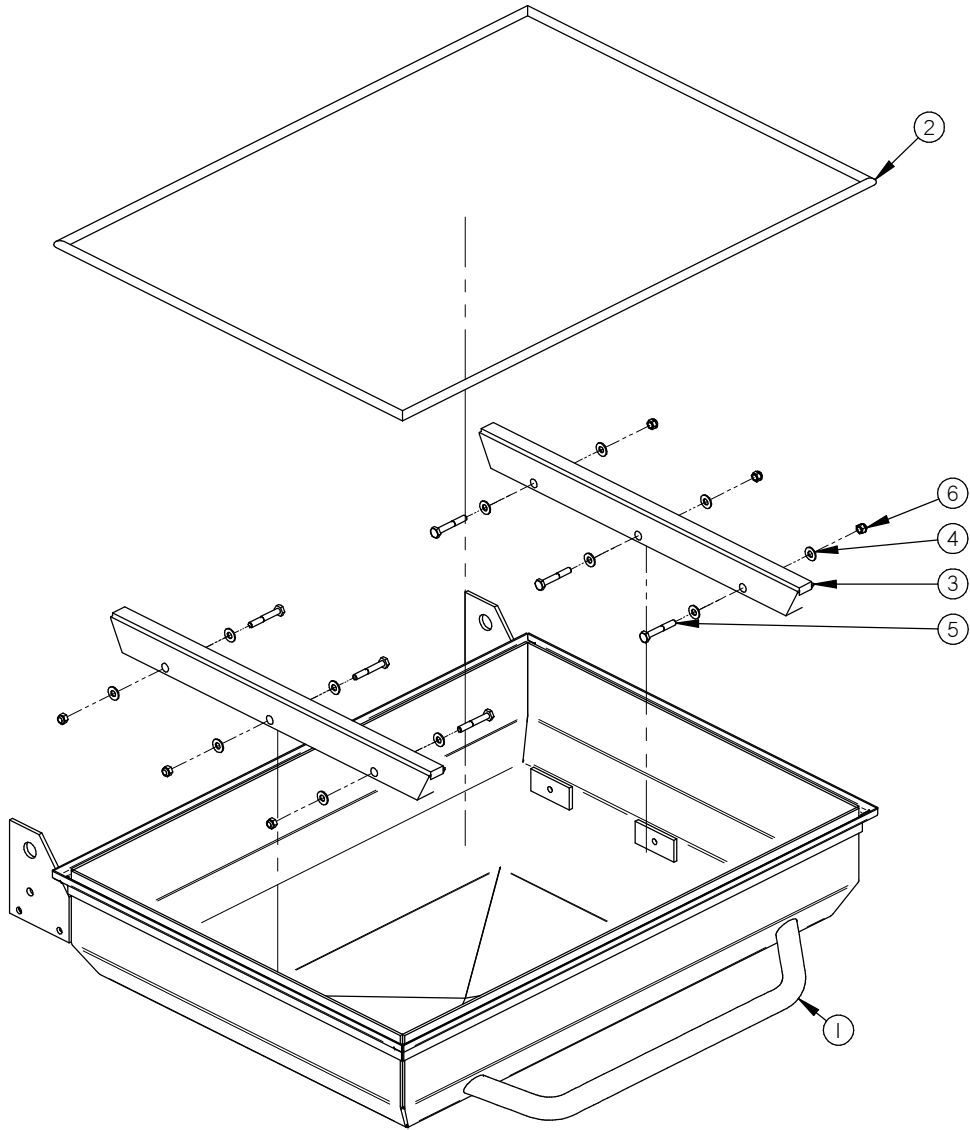

B	REDESSINE SE	13-08-06	SBU
A	ITEM 004A0351 WAS 004A0161	09-12-18	D.A.
LET.	MODIFICATION	DATE	INT.

MACHINE	<b>450T</b>		DEPT. TOL.	METRIC	INCH	SIPROMAC ST-GERMAIN DE GRANTHAM QUEBEC CANADA
PART	<b>COVER ASSEMBLY</b>		USINAGE	± 0.1	± 0.004"	
			TOLERIE	± 0.5	± 0.020"	
ITEM		CNC	SOUDEGE	± 0.5	± 0.020"	N.T.S.
MAT.		DWG BY <b>L.T.</b>	DATE	<b>03-01-21</b>		DEPT. <b>M</b> QTY. <b>1</b>
		APP. BY	DATE			<b>005-0444</b>

# 005B0583

ITEM	PART #	DESCRIPTION	QT.
1	003A0403	CONTROL INSERT	1
2	051-0092	SCREW #4-40 x 1 1/4" FLAT SLT S/S	4
3	051-0713	WASHER #4 FLAT S/S	4
4	058-0120	CPVC SPACER 0.120" x 1/4" x 5/8"	4
5	051-0540	NUT #4-40 HEX S/S	8
6	051-0715	WASHER #4 LOCK SS	4
7	033-0038	MC-40 SENSOR VACUUM	1
8	051-01095	SCREW 8-32 x 1/2 FLAT SLOT SS	6
9	179-0004	NITRILE 1/2" X 1/8" AUTOCOLLANT X 1220mm long	1

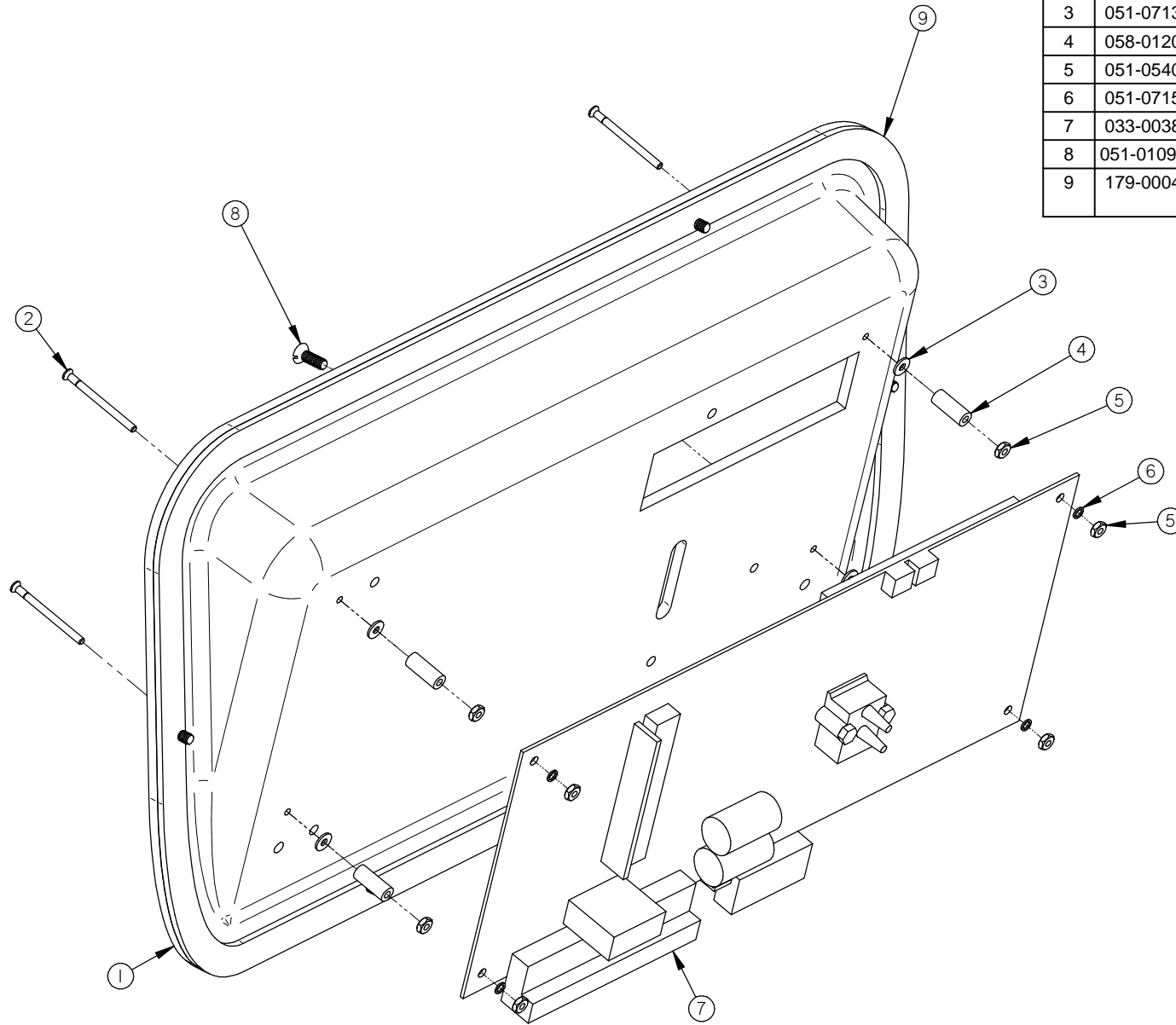

MACHINE		<b>VACUUM</b>		DEPT. TOL.	METRIC	INCH	SIPROMAC ST-GERMAIN DE GRANTHAM QUEBEC CANADA
PART		<b>MC-40 CONTROL BOARD</b>		USINAGE	± 0.1	± 0.004"	
				TOLERIE	± 0.5	± 0.020"	
				SOUDEAGE	± 0.5	± 0.020"	N.T.S.
ITEM		CNC		DEPT.	M		QTY. 1
MAT.		DWG BY	SBU	DATE	13-11-21		NO. <b>005B0583</b>
		APP. BY		DATE			

LET.	MODIFICATION	DATE	INT.
------	--------------	------	------

ITEM	PART #	DESCRIPTION	QT.
1	106-00701	VALVE 3WAY 24V 1/4"NPT	1
2	100-0225	CLOSE NIPPLE 1/4" NPT SS	1
3	100-0463	TEE 1/4" NPT S/S	1
4	114-2020	FILTER / DRYER ¼"mnpt. X 1/4"t.p. COMP.	1
5	101-0170	ELBOW 90° 1/4MNPTx1/4"HOSE	1
6	102-0330	ELBOW 1/4" NPT X 3/8" HOSE QUICK	1
7	104-0060	TUBE 3/8"OD x 1/4"ID POLYETHYL.	3
8	105-0218	EAR CLAMP 3/8" S/S	3
9	100-0065	STREET ELBOW 1/4" NPT SS	1
10	102-0361	Y BRANCH 1/4" MNPT X 3/8" T. QUICK	1
11	001A0564	VALVE SUPPORT	1
12	051-0571	NUT #10-24 S/S	6
13	051-0144	SCREW #10-24 N.C 1/2"PAN PHIL. S/S	4

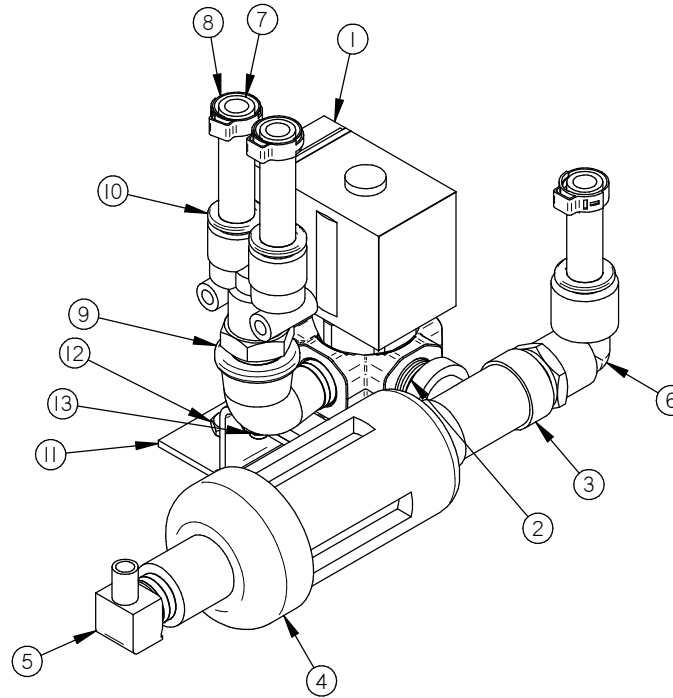

Error: No reference

MACHINE	<b>450T</b>		DEPT. TOL.	METRIC	INCH	SIPROMAC ST-GERMAIN DE GRANTHAM QUEBEC CANADA
PART	<b>BELLOWS VALVE ASSY</b>		USINAGE	± 0.1	± 0.004"	
			TOLERIE	± 0.5	± 0.020"	
			SOUDEAGE	± 0.5	± 0.020"	
ITEM	CNC	DEPT.	N.T.S.		M	QTY. 1
MAT.	3D DWG BY SBU	DATE 14-06-18	NO. 005A1513			
	2D DWG BY XX	DATE YY-MM-DD				

LET.	MODIFICATION	DATE	INT.
------	--------------	------	------

# 005A1512

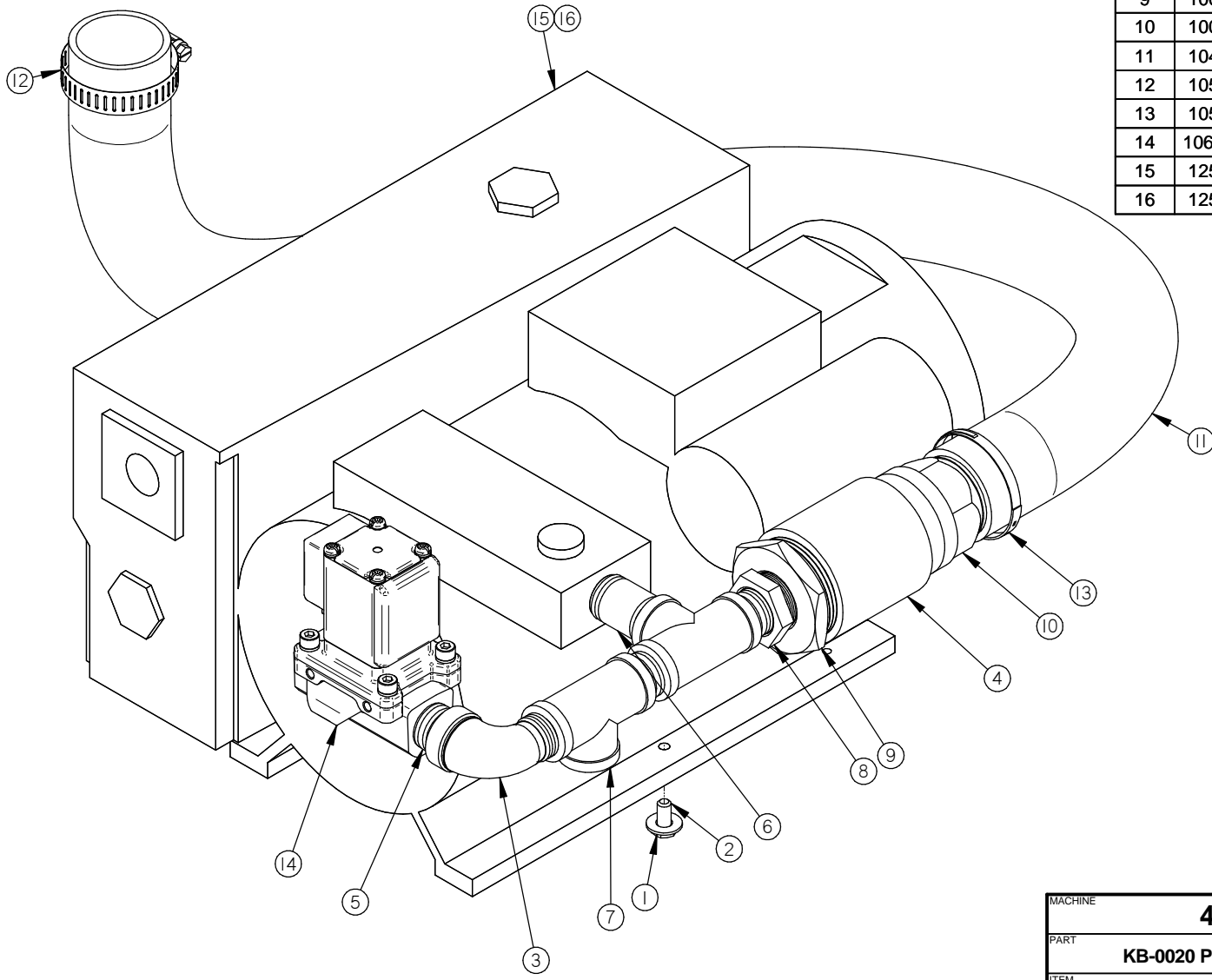

ITEM	PART #	DESCRIPTION	QT.
1	051-0740	WASHER 1/4" FLAT S/S	4
2	051-0948	BOLT M6 x 12 SS	4
3	100-0075	STREET ELBOW 1/2" NPT SS	1
4	100-0144	COUPLING 1-1/2" NPT S/S	1
5	100-0230	CLOSE NIPPLE 1/2" npt, S/S	3
6	100-0325	NIPPLE 1/2"npt. X 2" S/S	1
7	100-0465	TEE 1/2"npt. S/S	2
8	100-0520	RED.BUSH.3/4"NPT x 1/2"NPT S/S	1
9	100-0553	REDUCING BUSH. 1-1/2" NPT X 3/4" NPT SS	1
10	100-1230	STRAIGHT 1-1/2"MNPT x1-1/2" HOSE BARB	1
11	104-0130	HOSE 1-1/2" ID VACUUM TIGERFLEX 940MM	1
12	105-0110	SCREW CLAMPS 1-1/16" TO 2" ALL S/S	1
13	105-0250	EAR CLAMP 1-1/2" S/S	1
14	106-00201	VALVE 2WAY 24V 1/2" NPT	1
15	125-1020	BUSCH KB-0020 115V/1PH/60HZ	1
16	125-1021	BUSCH KB-0020 220-240V/1PH/50-60HZ	1

LET.	MODIFICATION	DATE	INT.
------	--------------	------	------

MACHINE		<b>450T</b>		DEPT. TOL.	METRIC	INCH	SIPROMAC ST-GERMAIN DE GRANTHAM QUEBEC CANADA
PART		<b>KB-0020 PUMP ASSEMBLY</b>		USINAGE	± 0.1	± 0.004"	
				TOLERIE	± 0.5	± 0.020"	
ITEM		CNC		SOUDEGE	± 0.5	± 0.020"	N.T.S.
MAT.		3D DWG BY <b>SBU</b>		DATE <b>14-06-18</b>		DEPT. <b>M</b> QTY. <b>1</b>	
		2D DWG BY <b>AG</b>		DATE <b>14-06-20</b>		<b>005A1512</b>	

# 004B4113

ITEM	PART #	DESCRIPTION	QT.
1	106-0010	VALVE 2WAY N.C. 24VAC 1/4" NPT(SMC)	1
2	102-0330	ELBOW 1/4" NPT X 3/8" HOSE QUICK	1
3	100-0065	STREET ELBOW 1/4" NPT SS	1
4	102-0361	Y BRANCH 1/4" MNPT X 3/8" T. QUICK	1

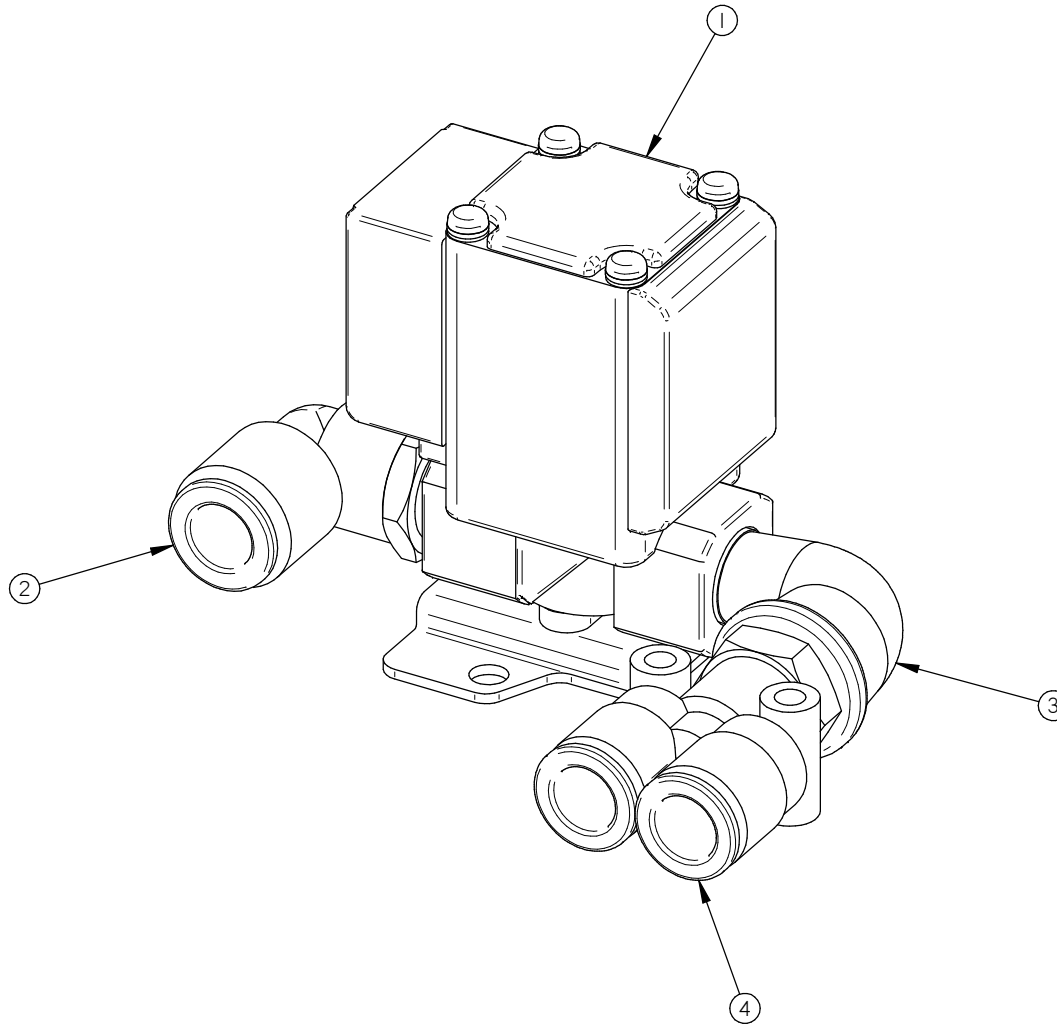

## -OPTION - GAS

DOUBLE CHAMBER	2
SINGLE CHAMBER	1
MACHINE	QTY

MACHINE		<b>VACUUM</b>		DEPT. TOL.	METRIC	INCH.	SIPROMAC ST-GERMAIN DE GRANTHAM QUEBEC CANADA
PART		<b>GAS VALVE ASSEMBLY (OPTION)</b>		USINAGE	± 0.1	± 0.004"	
ITEM				TOLERIE	± 0.5	± 0.020"	
MAT.				SOUDEAGE	± 0.5	± 0.020"	N.T.S.
		CNC		DEPT.		<b>M</b>	QTY
		DWG BY	<b>SBU</b>	DATE	<b>14-05-27</b>	NO.	<b>LISTE</b>
		APP. BY		DATE		<b>004B4113</b>	

A	VALVE UPDATE	14-05-27	SBU
LET.	MODIFICATION	DATE	INT.

# 005A1496

ITEM	PART #	DESCRIPTION	QT.
1	001A6811	AIR REGULATOR SUPPORT	1
2	051-0180	BOLT. HEX. 1/4"-20 NC. x 1/2" S/S	2
3	051-0740	WASHER 1/4" FLAT S/S	2
4	102-0330	ELBOW 1/4" NPT X 3/8" HOSE QUICK	2
5	114-01501	PRESSURE REGUL.0-100 PSI 1/4" NPT W/ NUT	1
6	114-0236	PRESSURE GAUGE 30 PSI 1/8" NPT BOTTOM	1

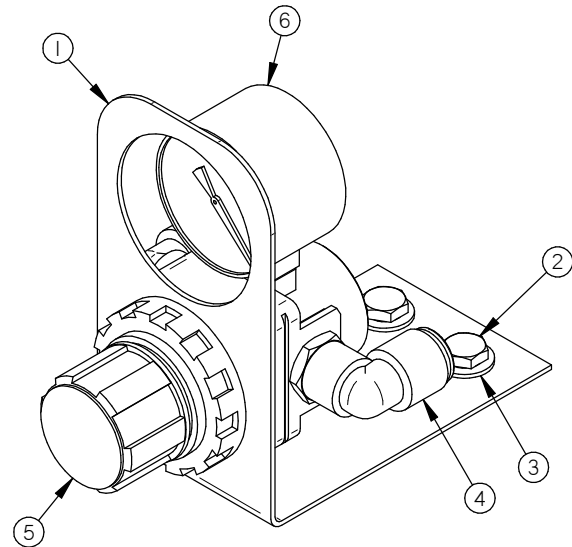
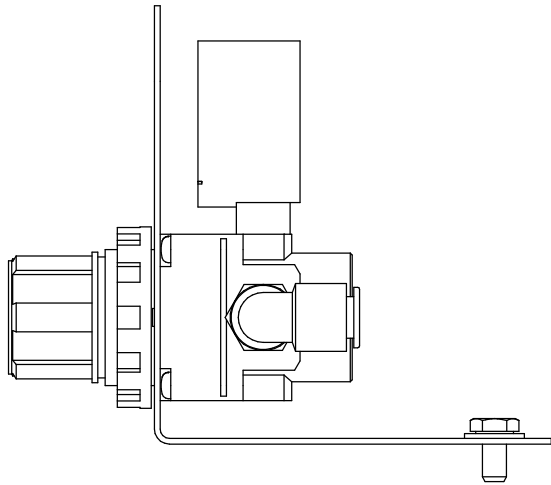
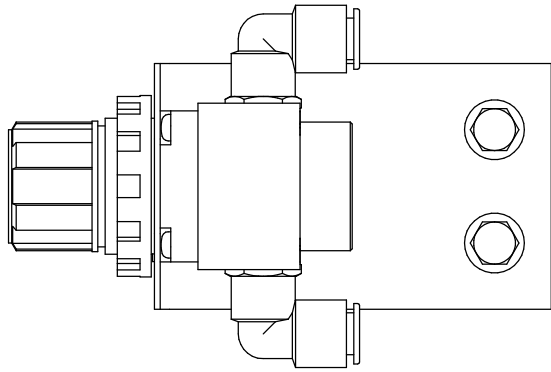

## -AIR REGULATOR OPTION -

MACHINE		DEPT. TOL. METRIC		INCH		SIPROMAC	
<b>TABLE TOP VACUUM</b>		USINAGE	± 0.1	± 0.004"	ST-GERMAIN DE GRANTHAM QUEBEC CANADA		
PART		TOLERIE	± 0.5	± 0.020"			
<b>AIR REGULATOR VALVE ASSY</b>		SOUDAGE	± 0.5	± 0.020"			
ITEM		CNC	N.T.S.		DEPT.	M	QTY. 1
MAT.		DWG BY	SBU (A.G)	DATE	14-06-09	NO. <b>005A1496</b>	
		APP. BY			DATE		

LET.	MODIFICATION	DATE	INT.
------	--------------	------	------

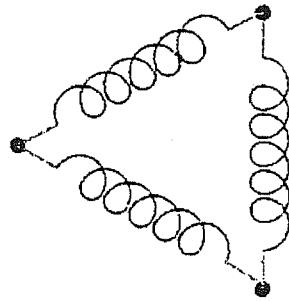
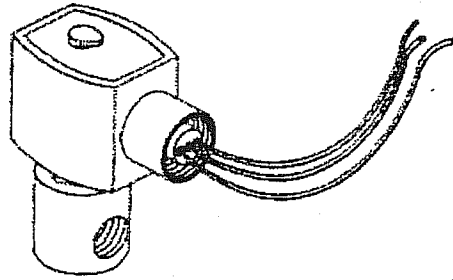
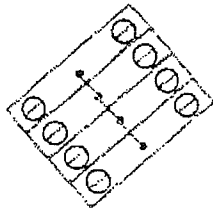

**ELECTRICAL DRAWING**

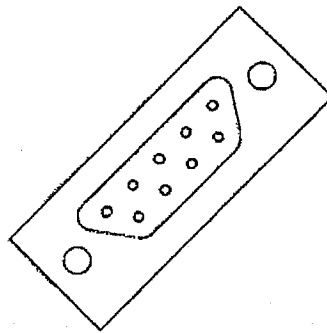
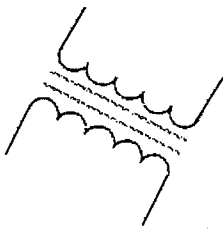

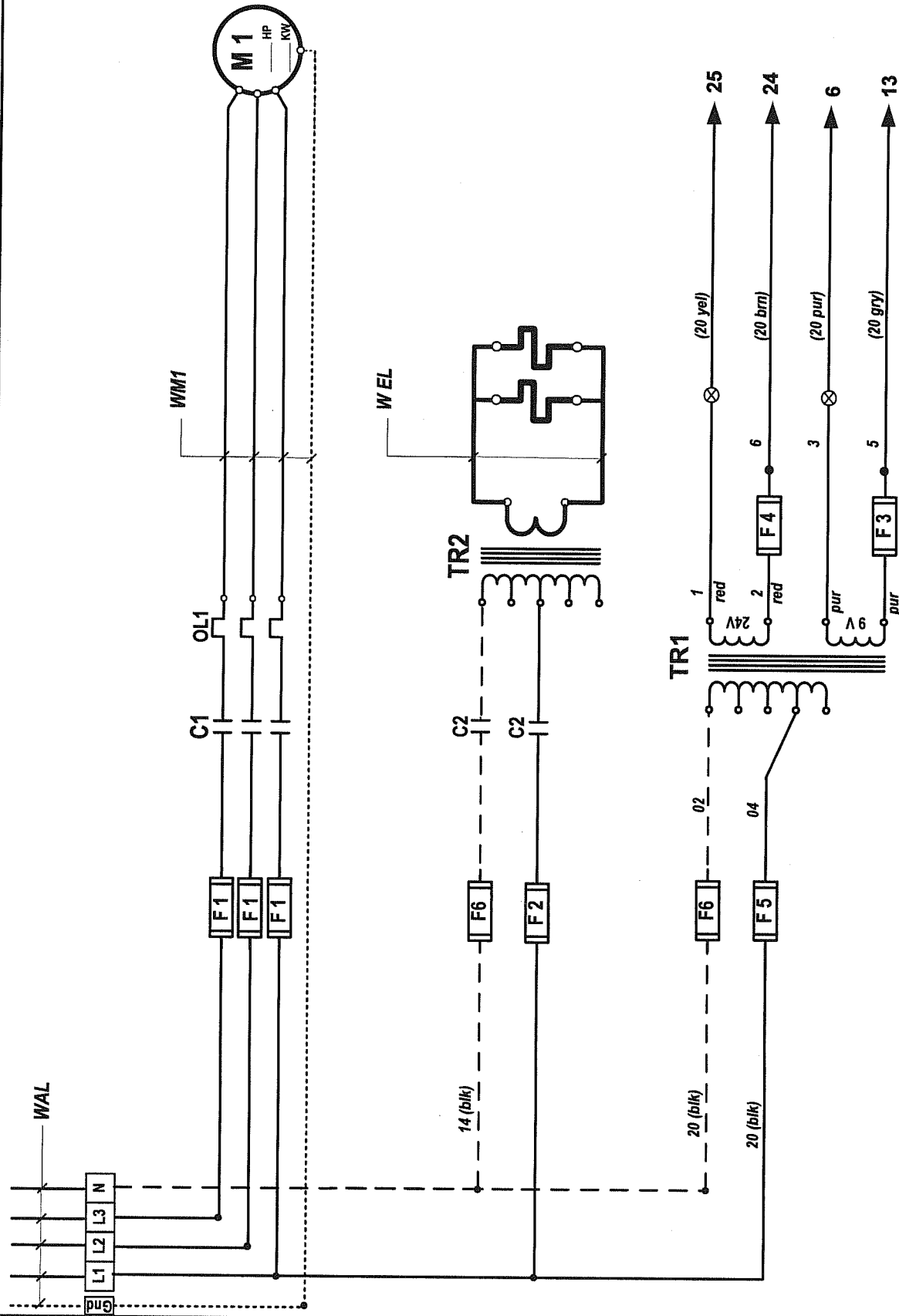

category		VOL.		3Ph 60Hz		block	
VACUUM PACK		450T		year month day		05 01 18	
system		MC-40		concept draw app		PP PP DL	
usual fonctions options				PP PP DL		006-0830 PAGE 1 de 1	

**SIPROMAC**  
 St-Germain de Grantham  
 QUEBEC, CANADA

OUT

MC40

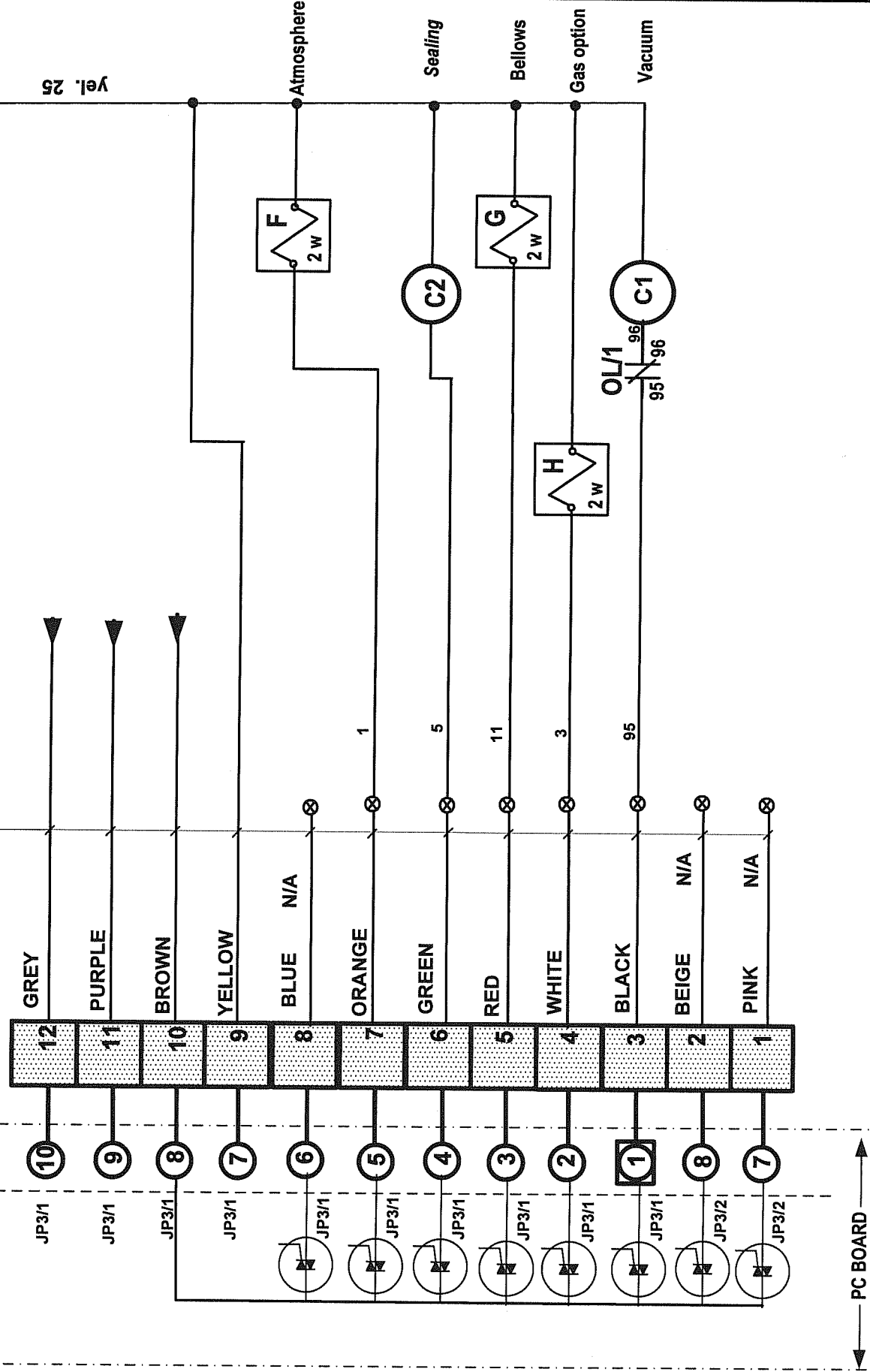

TRANSF.CONT.

W001

category	VACUUM PACK	model	450T	voit	ALL
system	MC-40	circuit	control	year	10 07 08
usual		concept	draw	app	PP DL
fonctions		options			
				block	006-0737
				year	10 07 08
				concept	XX
				draw	PP
				app	DL
				year	10 07 08
				month	10 07 08
				day	10 07 08
				block	006-0737
				year	10 07 08
				concept	XX
				draw	PP
				app	DL
				year	10 07 08
				month	10 07 08
				day	10 07 08
				block	006-0737
				year	10 07 08
				concept	XX
				draw	PP
				app	DL
				year	10 07 08
				month	10 07 08
				day	10 07 08
				block	006-0737
				year	10 07 08
				concept	XX
				draw	PP
				app	DL
				year	10 07 08
				month	10 07 08
				day	10 07 08
				block	006-0737
				year	10 07 08
				concept	XX
				draw	PP
				app	DL
				year	10 07 08
				month	10 07 08
				day	10 07 08
				block	006-0737
				year	10 07 08
				concept	XX
				draw	PP
				app	DL
				year	10 07 08
				month	10 07 08
				day	10 07 08
				block	006-0737
				year	10 07 08
				concept	XX
				draw	PP
				app	DL
				year	10 07 08
				month	10 07 08
				day	10 07 08
				block	006-0737
				year	10 07 08
				concept	XX
				draw	PP
				app	DL
				year	10 07 08
				month	10 07 08
				day	10 07 08
				block	006-0737
				year	10 07 08
				concept	XX
				draw	PP
				app	DL
				year	10 07 08
				month	10 07 08
				day	10 07 08
				block	006-0737
				year	10 07 08
				concept	XX
				draw	PP
				app	DL
				year	10 07 08
				month	10 07 08
				day	10 07 08
				block	006-0737
				year	10 07 08
				concept	XX
				draw	PP
				app	DL
				year	10 07 08
				month	10 07 08
				day	10 07 08
				block	006-0737
				year	10 07 08
				concept	XX
				draw	PP
				app	DL
				year	10 07 08
				month	10 07 08
				day	10 07 08
				block	006-0737
				year	10 07 08
				concept	XX
				draw	PP
				app	DL
				year	10 07 08
				month	10 07 08
				day	10 07 08
				block	006-0737
				year	10 07 08
				concept	XX
				draw	PP
				app	DL
				year	10 07 08
				month	10 07 08
				day	10 07 08
				block	006-0737
				year	10 07 08
				concept	XX
				draw	PP
				app	DL
				year	10 07 08
				month	10 07 08
				day	10 07 08
				block	006-0737
				year	10 07 08
				concept	XX
				draw	PP
				app	DL
				year	10 07 08
				month	10 07 08
				day	10 07 08
				block	006-0737
				year	10 07 08
				concept	XX
				draw	PP
				app	DL
				year	10 07 08
				month	10 07 08
				day	10 07 08
				block	006-0737
				year	10 07 08
				concept	XX
				draw	PP
				app	DL
				year	10 07 08
				month	10 07 08
				day	10 07 08
				block	006-0737
				year	10 07 08
				concept	XX
				draw	PP
				app	DL
				year	10 07 08
				month	10 07 08
				day	10 07 08
				block	006-0737
				year	10 07 08
				concept	XX
				draw	PP
				app	DL
				year	10 07 08
				month	10 07 08
				day	10 07 08
				block	006-0737
				year	10 07 08
				concept	XX
				draw	PP
				app	DL
				year	10 07 08
				month	10 07 08
				day	10 07 08
				block	006-0737
				year	10 07 08
				concept	XX
				draw	PP
				app	DL
				year	10 07 08
				month	10 07 08
				day	10 07 08
				block	006-0737
				year	10 07 08
				concept	XX
				draw	PP
				app	DL
				year	10 07 08
				month	10 07 08
				day	10 07 08
				block	006-0737
				year	10 07 08
				concept	XX
				draw	PP
				app	DL
				year	10 07 08
				month	10 07 08
				day	10 07 08
				block	006-0737
				year	10 07 08
				concept	XX
				draw	PP
				app	DL
				year	10 07 08
				month	10 07 08
				day	10 07 08
				block	006-0737
				year	10 07 08
				concept	XX
				draw	PP
				app	DL
				year	10 07 08
				month	10 07 08
				day	10 07 08
				block	006-0737
				year	10 07 08
				concept	XX
				draw	PP
				app	DL
				year	10 07 08
				month	10 07 08
				day	10 07 08
				block	006-0737
				year	10 07 08
				concept	XX
				draw	PP
				app	DL
				year	10 07 08
				month	10 07 08
				day	10 07 08
				block	006-0737
				year	10 07 08
				concept	XX
				draw	PP
				app	DL
				year	10 07 08
				month	10 07 08
				day	10 07 08
				block	006-0737
				year	10 07 08
				concept	XX
				draw	PP
				app	DL
				year	10 07 08
				month	10 07 08
				day	10 07 08
				block	006-0737
				year	10 07 08
				concept	XX
				draw	PP
				app	DL
				year	10 07 08
				month	10 07 08
				day	10 07 08
				block	006-0737
				year	10 07 08
				concept	XX
				draw	PP
				app	DL
				year	10 07 08
				month	10 07 08
				day	10 07 08
				block	006-0737
				year	10 07 08
				concept	XX
				draw	PP
				app	DL
				year	10 07 08
				month	10 07 08
				day	10 07 08
				block	006-0737
				year	10 07 08
				concept	XX
				draw	PP
				app	DL
				year	10 07 08
				month	10 07 08
				day	10 07 08
				block	006-0737
				year	10 07 08
				concept	XX
				draw	PP
				app	DL
				year	10 07 08
				month	10 07 08
				day	10 07 08
				block	006-0737
				year	10 07 08
				concept	XX
				draw	PP
				app	DL
				year	10 07 08
				month	10 07 08
				day	10 07 08
				block	006-0737
				year	10 07 08
				concept	XX
				draw	PP
				app	DL
				year	10 07 08
				month	10 07 08
				day	10 07 08
				block	006-0737
				year	10 07 08
				concept	XX
				draw	PP
				app	DL
				year	10 07 08
				month	10 07 08
				day	10 07 08
				block	006-0737
				year	10 07 08
				concept	XX
				draw	PP
				app	DL
				year	10 07 08
				month	10 07 08
				day	10 07 08
				block	006-0737
				year	10 07 08
				concept	XX
				draw	PP
				app	DL
				year	10 07 08
				month	10 07 08
				day	10 07 08
				block	006-0737
				year	10 07 08
				concept	XX
				draw	PP
				app	DL
				year	10 07 08
				month	10 07 08
				day	10 07 08
				block	006-0737
				year	10 07 08
				concept	XX
				draw	PP
				app	DL
				year	10 07 08
				month	10 07 08
				day	10 07 08
				block	006-0737
				year	10 07 08

#	PART DESCRIPTION	PART APPLICATION	MACHINE VOLTAGE	MACHINE	REF.	OPT.	QTY
036-1510	MALE PLUG 20 AMP / 125 V.	SUPPLY	120V/1PH/60HZ	450T	GND-L1-N		1
030-0120	CAB TIRE	SUPPLY	120V/1PH/60HZ	450T	GND-L1-N		3M.
028-0105	GROUND BARRIER (6 HOLES)	SUPPLY	ALL	450T	GND		1
034-0755	FUSE HOLDER 30A 1 PÔLE	VACUUM KB-20	120V/1PH/60HZ	450T	F1		1
034-0530	FUSE MIDGET 20A/250V TIME-DELAY	VACUUM KB-20	120V/1PH/60HZ	450T	F1		1
025-0030	MOTOR CONTACTOR 1HP IN 120V-CSA,UL	VACUUM KB-20	120V/1PH/60HZ	450T	C1		1
025-0190	THERMAL OVERLOAD 1/2 TO 18A-CSA,UL	VACUUM KB-20	120V/1PH/60HZ	450T	O/L1		1
030-0430	TEW #14/41 BLACK	VACUUM KB-20	120V/1PH/60HZ	450T	WM1		1M.
030-0440	TEW #14/41 GREEN	VACUUM KB-20	120V/1PH/60HZ	450T	WM1		0.5M.
125-1020	VACUUM PUMP 110-120V/1PH/60HZ 0.75KW 13A	VACUUM KB-20	120V/1PH/60HZ	450T	M1		1
034-0755	FUSE HOLDER 30A 1 PÔLE	SEALING	120V/1PH/60HZ	450T	F2		1
034-0500	FUSE MIDGET 15A/250V TIME-DELAY	SEALING	120V/1PH/60HZ	450T	F2		1
025-0020	CONTACTOR ITH=25A-CSA,UL	SEALING	120V/1PH/60HZ	450T	C2		1
029-0030	TRANSFO 500VA/120V/24V/60HZ	SEALING	120V/1PH/60HZ	450T	TR2		1
027-0220	TERMINAL ROUND STUD #10 600V 75°C	SEALING	ALL	450T	WEL		4
030-0410	TEW #10/104 BLACK	SEALING	ALL	450T	WEL		4M.
027-0065	TERMINAL FLAG FEMALE YELLOW .250"	SEALING	ALL	450T	WEL		4
005-0564	SEAL BAR ASSEMBLY W/SUPPORT	SEALING TWIN SEAL	ALL	450T		A1	2
005-0565	SEAL BAR ASSEMBLY W/SUPPORT	SEALING BAG CUT	ALL	450T		A2	2
034-0740	FUSE HOLDER M4/8SF	CONTROL TRANSFO	120V/1PH/60HZ	450T	F5		1
034-0200	FUSE 5X20MM 3/4A 250V T-DELAY	CONTROL TRANSFO	120V/1PH/60HZ	450T	F5		1
029-0008	TRANSFO 65VA/120V/24-9V	CONTROL TRANSFO	120V/1PH/60HZ	450T	TR1		1
034-0740	FUSE HOLDER M4/8SF	CONTROL 9VAC+24VAC	ALL	450T	F3+F4		2
034-0210	FUSE 5X20MM 2A/250V TIME DELAY	CONTROL 9VAC	ALL	450T	F3		1
034-0240	FUSE 5X20MM 4A/250V TIME DELAY	CONTROL 24VAC	ALL	450T	F4		1
030-0590	20AWG/12COND.PVC,UNSHIELD.300V	OUTPUT CONTROL	ALL	450T	W001		1M.
036-0740	12 CONTACTS CONNECTOR	OUTPUT CONTROL	ALL	450T	JP3/1-2		1
030-0631	22AWG/4COND.PVC,SHIELDED,300V.	INPUT CONTROL	ALL	450T	WCV		2M.
036-0820	0.156" CENTERLINE CRIMP HOUSING	INPUT CONTROL	ALL	450T	JP4		1
036-0850	0.156" CENTERLINE CRIMP TERMINAL	INPUT CONTROL	ALL	450T	JP4		2
033-0038	MICROPROCESSOR MC-40 SENSOR VACUUM	CONTROL WITH SENSOR	ALL	450T	MC-40	B1	1
033-00385	MICROPROCESSOR MC-40 NO SENSOR VAC.	CONTROL W/O SENSOR	ALL	450T	MC-40	B2	1
033-0015	MEMBRANE MC-40 SIPROMAC	CONTROL SIPROMAC	ALL	450T		C1	1
033-0018	MEMBRANE MC-40 BERKEL	CONTROL BERKEL	ALL	450T		C2	1
106-0030	VALVE 2WAY 24V 3/4 NPT(G95) 60HZ	ATMOSPHERE	ALL	450T	F		1
106-0070	VALVE 3WAY 24V 1/4 NPT(G176)60HZ	BELLOWS	ALL	450T	G		1
106-0010	VALVE 2WAY 24V 1/4 NPT(G22) 60HZ	OPTION GAS	ALL	450T	H	D	1
026-0610	LIMIT SWITCH LONG ROLLER 15A 280V	COVER POSITION	ALL	450T	CV		1
036-1512	MALE PLUG 15 AMP / 250 V.	SUPPLY	220V/1PH/60HZ	450T	GND-L1-L2		1
030-0160	CAB TIRE	SUPPLY	220V/1PH/60HZ	450T	GND-L1-L2		3 M.

#	SIPRO	PART DESCRIPTION	PART APPLICATION	MACHINE VOLTAGE	MACHINE	REF.	OPT.	QTY
028-0105		GROUND BARRIER (6 HOLES)	SUPPLY	ALL	450T	GND		1
034-0755		FUSE HOLDER 30A 1 PÖLE	VACUUM KB-20	220V/1PH/60HZ	450T	F1		2
034-0500		FUSE MIDGET 15A/250V TIME-DELAY	VACUUM KB-20	220V/1PH/60HZ	450T	F1		2
025-0010		MOTOR CONTACTOR 1HP IN 220V MONO-CSA,UL	VACUUM KB-20	220V/1PH/60HZ	450T	C1		1
025-0160		THERMAL OVERLOAD 5.5 TO 8A-CSA,UL	VACUUM KB-20	220V/1PH/60HZ	450T	O/L1		1
030-0430		TEW #14/141 BLACK	VACUUM KB-20	220V/1PH/60HZ	450T	WM1		1M.
030-0440		TEW #14/141 GREEN	VACUUM KB-20	220V/1PH/60HZ	450T	WM1		0.5M.
125-1021		BUSCH KB-0020 220-240V/1PH/60HZ 0.75KW 6.5A	VACUUM KB-20	220V/1PH/60HZ	450T	M1		1
034-0755		FUSE HOLDER 30A 1 PÖLE	SEALING	220V/1PH/60HZ	450T	F2		2
034-0500		FUSE MIDGET 15A/250V TIME-DELAY	SEALING	220V/1PH/60HZ	450T	F2		2
025-0020		CONTACTOR ITH=25A-CSA,UL	SEALING	220V/1PH/60HZ	450T	C2		1
029-0045		TRANSFO 500VA/220-400-460V/24V	SEALING	220V/1PH/60HZ	450T	TR2		1
027-0220		TERMINAL ROUND STUD #10 600V 75°C	SEALING	ALL	450T	WEL		4
030-0410		TEW #10/104 BLACK	SEALING	ALL	450T	WEL		4M.
027-0065		TERMINAL FLAG FEMALE YELLOW .250"	SEALING	ALL	450T	WEL		4
005-0564		SEAL BAR ASSEMBLY W/SUPPORT	SEALING TWIN SEAL	ALL	450T		A1	2
005-0565		SEAL BAR ASSEMBLY W/SUPPORT	SEALING BAG CUT	ALL	450T		A2	2
034-0740		FUSE HOLDER M4/8SF	CONTROL TRANSFO	220V/1PH/60HZ	450T	F5		2
034-0200		FUSE 5X20MM 3/4A 250V T-DELAY	CONTROL TRANSFO	220V/1PH/60HZ	450T	F5		2
029-0007		TRANSFO 65VA/220-230-460V/24-9	CONTROL TRANSFO	220V/1PH/60HZ	450T	TR1		1
034-0740		FUSE HOLDER M4/8SF	CONTROL 9VAC+24VAC	ALL	450T	F3+F4		2
034-0210		FUSE 5X20MM 2A/250V TIME DELAY	CONTROL 9VAC	ALL	450T	F3		1
034-0240		FUSE 5X20MM 4A/250V TIME DELAY	CONTROL 24VAC	ALL	450T	F4		1
030-0590		20AWG/12COND.PVC,UNSHIELD.300V	OUTPUT CONTROL	ALL	450T	W001		1M.
036-0740		12 CONTACTS CONNECTOR	OUTPUT CONTROL	ALL	450T	JP3/1-2		1
030-0631		22AWG/4COND.PVC,SHIELDED,300V.	INPUT CONTROL	ALL	450T	WCV		2M.
036-0820		0.156" CENTERLINE CRIMP HOUSING	INPUT CONTROL	ALL	450T	JP4		1
036-0850		0.156" CENTERLINE CRIMP TERMINAL	INPUT CONTROL	ALL	450T	JP4		2
033-0038		MICROPROCESSOR MC-40 SENSOR VACUUM	CONTROL WITH SENSOR	ALL	450T	MC-40	B1	1
033-00385		MICROPROCESSOR MC-40 NO SENSOR VAC.	CONTROL W/O SENSOR	ALL	450T	MC-40	B2	1
033-0015		MEMBRANE MC-40 SIPROMAC	CONTROL SIPROMAC	ALL	450T		C1	1
033-0018		MEMBRANE MC-40 BERKEL	CONTROL BERKEL	ALL	450T		C2	1
106-0030		VALVE 2WAY 24V 3/4 NPT(G95) 60HZ	ATMOSPHERE	ALL	450T	F		1
106-0070		VALVE 3WAY 24V 1/4 NPT(G176)60HZ	BELLOWS	ALL	450T	G		1
106-0010		VALVE 2WAY 24V 1/4 NPT(G22) 60HZ	OPTION GAS	ALL	450T	H	D	1
026-0610		LIMIT SWITCH LONG ROLLER 15A 250V	COVER POSITION	ALL	450T	CV		1

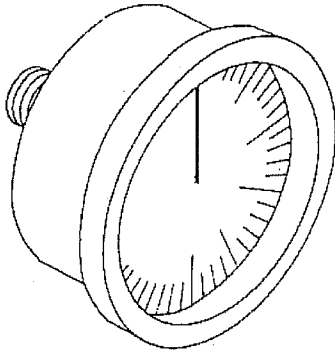

# PNEUMATIC DRAWING

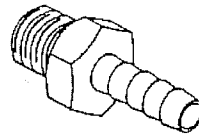
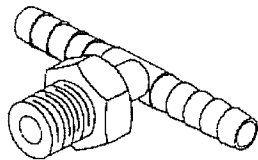

007-0036

ITEM	PART #	DESCRIPTION	QT.
1	106-0010	GAS VALVE	1
2	114-0260	VACUUM GAUGE	1
3	106-0070	BELLOWS VALVE	1
4	106-0020	ATMOSPHERE VALVE	1
5	114-0147	PRESSURE REGULATOR	1
6	114-0245	PRESSURE GAUGE	1
7	114-0170	PRESSURE REGULATOR SUPPORT	1

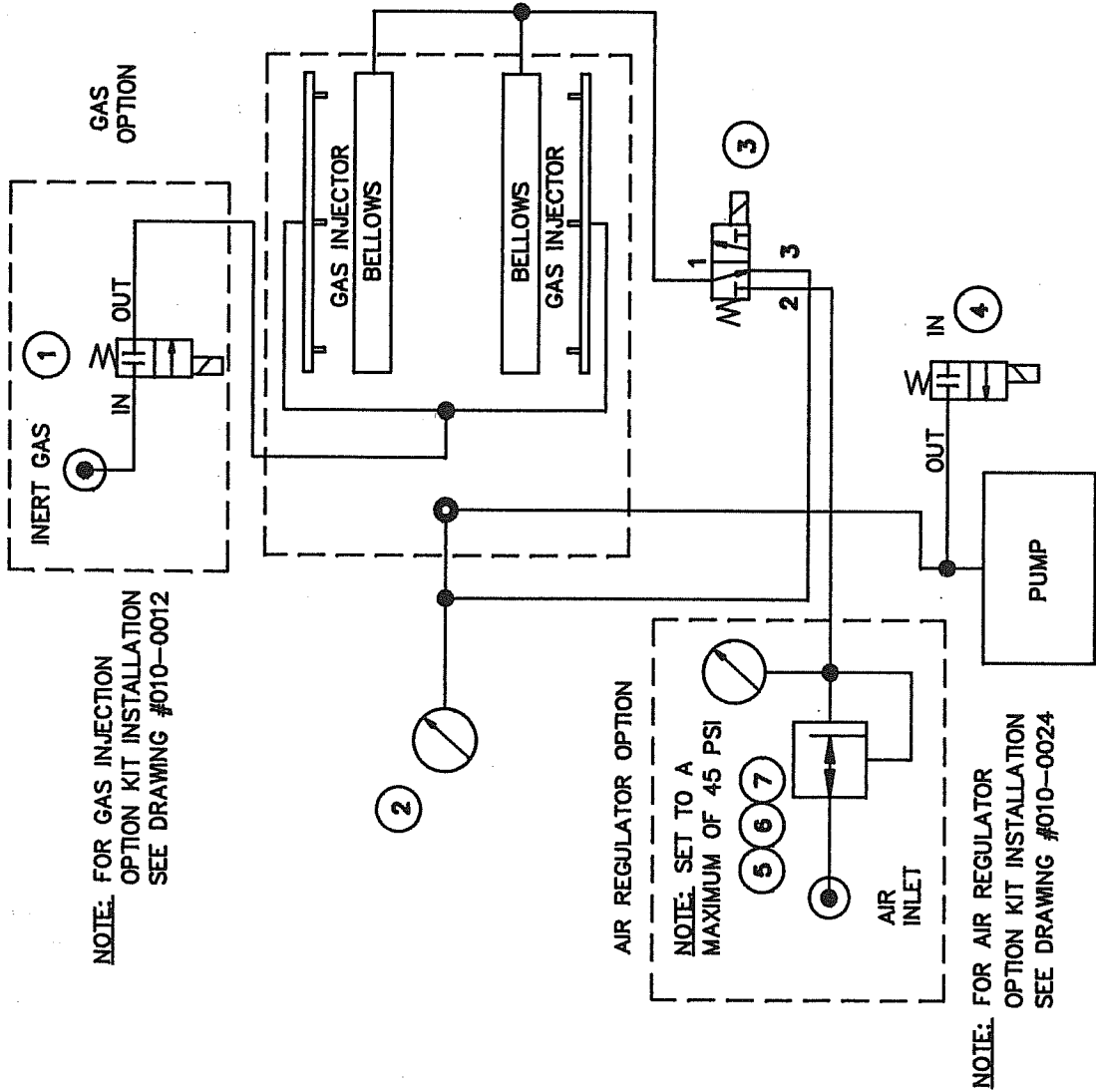

NOTE: FOR GAS INJECTION  
OPTION KIT INSTALLATION  
SEE DRAWING #010-0012

NOTE: SET TO A  
MAXIMUM OF 45 PSI

NOTE: FOR AIR REGULATOR  
OPTION KIT INSTALLATION  
SEE DRAWING #010-0024

MACHINE		450T		SIPROMAC	
PART		PNEUMATIC DRAWING		ST-GERMAIN DE GRANTHAM, QUEBEC CANADA	
ITEM:	CNC:	SCALE:	GT:	1	
MAT:	DWG BY M.LAVIGNE	DATE	97-03-12	NO.	007-0036
LET.	APP.	DATE			
A	RE-DRAWN	MODIFICATION			

ITEM	PART #	DESCRIPTION	QT.
1	005-0536	MACHINE ASSEMBLY FRONT VIEW	1
2	005-0564	SEAL BAR ASSY W/ SUPPORT	2
3	005-0565	SEAL BAR ASSY W/ SUPPORT (BAG CUT OPT.)	2
4	005-0539	MACHINE ASSEMBLY REAR VIEW	1
5	005A0808	RIGHT GAS INJECTION BAR ASSY (OPT.)	1
6	005A0533	LEFT GAS INJECTION BAR ASSY (OPT.)	1
7	008-0464	GAS INJECTION CONNECTION TUBE	2
8	106-0010	SELENOID VALVE 2 WAY 1/4" NPT W/ SUPP.	1
9	005-0323	GAS INLET ASSEMBLY	1
10	051-0190	HEX. BOLT 1/4"-20 NC X 3/4" S/S	2
11	051-0580	HEX. NUT 1/4"-20 NC S/S	3
12	101-0036	STRAIGHT 1/4" MNPT X 3/8" T.P.COMP.	1
13	101-0065	T 3/8" I.P.COMP. X 1/4" MNPT X 3/8" I.P.COMP.	1
14	104-0060	TUBE 3/8" O.D. X 1/4" I.D. (POLY.) X mm LG.	1
15	104-0060	TUBE 3/8" O.D. X 1/4" I.D. (POLY.) X mm LG.	1
16	104-0060	TUBE 3/8" O.D. X 1/4" I.D. (POLY.) X mm LG.	1
17	105-0200	COLLARS 3/8"φ	3
18	051-0740	FLAT WASHER 1/4" S/S	1

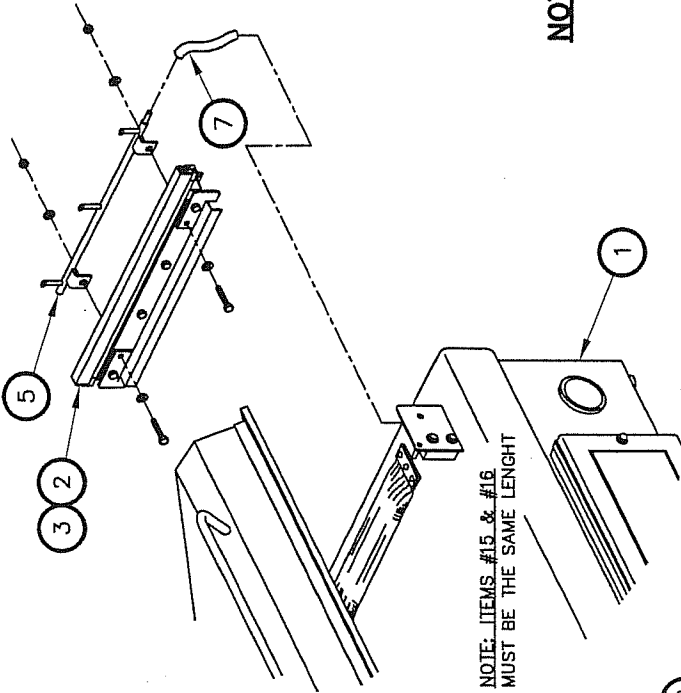

**NOTE:**

- PARTS ① THRU ④ ARE EXISTING PARTS
- PARTS ⑤ THRU ⑱ ARE PARTS SUPPLIED W/ KIT

**-FRONT VIEW-**

**-GAS INJECTION BAR INSTALLATION-**

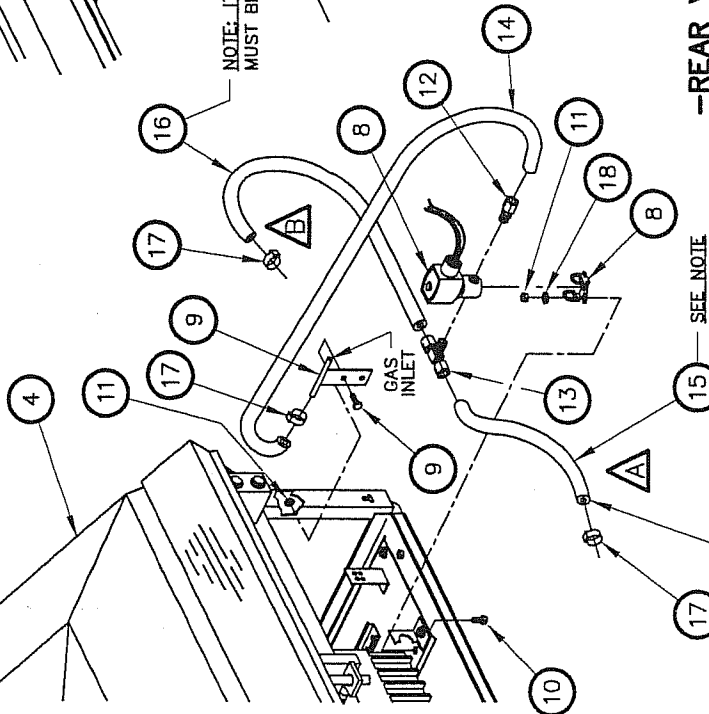

**-REAR VIEW-**

**-VALVE INSTALLATION-**

TO GAS INJECTION TUBES UNDER TABLE REMOVE THE TWO EXISTING CAPS & CONNECT HOSES A & B

SEE NOTE

TO GAS INJECTION TUBES UNDER TABLE REMOVE THE TWO EXISTING CAPS & CONNECT HOSES A & B

SEE NOTE

F	CHANGED SEAL BARS&GAS INL.FOR 450A MODEL.	08-05-26	D.A.
E	MODIFICATION #A-358	03-02-21	J.G.
D	REDRAWN/ MODIF. NO. A-0228	97-10-23	A.P.
LET.	MODIFICATION	DATE	INT.

**-GAS INJECTION OPTION-**

MACHINE: **450T**

PART: **GAS INJECTION KIT INSTALLATION**

ITEM: \_\_\_\_\_

DATE: 97-10-23

QTY: 1

DEPT: M-(P)

ST: GERMAN DE GRANTHAM

QUEBEC CANADA

SIPROMAC

010-0012

010-0024

ITEM	PART #	DESCRIPTION	QT.
1	005-0411	MACHINE ASSEMBLY REAR VIEW	1
2	114-0147	PR.REG. 0-60 PSI 1/4"NPT	1
3	114-0245	PR.GAUGE 0-60 PSI 1/8"NPT	1
4	114-0170	PR.REGULATOR SUPPORT	1
5	051-0147	SCREW #10-24 x 1" HEX. S/S	2
6	051-0730	WASHER #10 FLAT S/S	2
7	051-0572	NUT #10-24 NYLON LOCK S/S	2
8	101-0059	ELBOW 90° 1/4"NPT x 3/8" T.P.COMP.	2
9	101-0200	STRAIGHT 1/4"MNPT x 1/4" HOSE BARB	1
10	104-0060	TUBE 3/8"ODx1/4"ID(POLY)x mMLG.	1

--NOTE:--

MACHINE REAR VIEW  
SHOWN WITHOUT REAR COVER

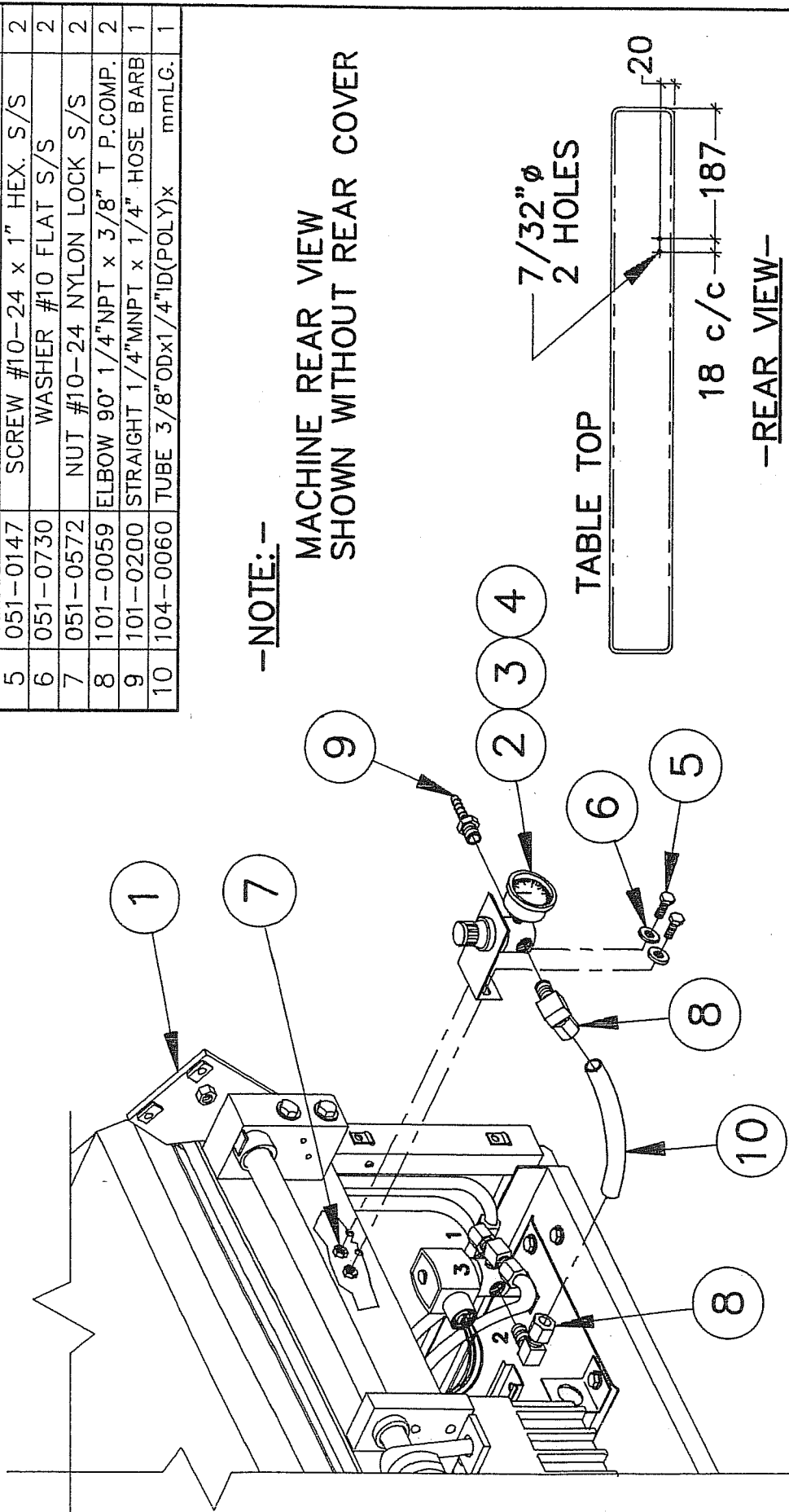

MACHINE	450T	SIPROMAC
PART	AIR REGULATOR OPTION KIT INSTALLATION	ST-GERMAIN DE GRANITHAM QUEBEC CANADA
ITEM:	CNC:	M-E QT. 1
MAT:	DWG BY M.LAVIGNE	DATE 95-12-04
DATE	APP.	NO. 010-0024
96-12-12	96-12-12	M.L.
DATE	DATE	INT.
MODIFICATION		
LET.		

# **MANUEL D'UTILISATEUR**

## **MICROPROCESSEUR MC-40**

### **AVEC OU SANS DÉTECTEUR DE VIDE**

#### **EMBALLÉUSE SOUS VIDE**

#### **TABLE DES MATIÈRES**

##### **I INSTRUCTIONS POUR LES OPÉRATIONS**

##### **II MÉCANIQUE**

- A- Vue de face
- B- Vue de l'arrière
- C- Procédure d'ajustement du couvert
- D- Schéma de l'assemblage de l'axe central
- E- Barres de scellage  
(Double scellage)
- F- Dessin des barres de scellage  
(Option du coupe sac électrique)
- G- Dessins des barres d'assemblage  
(Scellage du haut et du bas en option)
- H- Gas injection kit installation drawing  
(gaz injection option)

##### **III ELECTRIQUE**

- A- Schéma électrique (Bas voltage)
- B- Schéma électrique (Haut voltage à une phase)
- C- Schéma électrique (Haut voltage à 3 phases)
- D- Schéma électrique (Haut voltage 1 phase 50 Hz)
- E- Schéma électrique (Haut voltage 3 phase 50 Hz)

##### **IV PNEUMATIQUE**

- A- Schéma Pneumatique

# EMBALLEUSES SOUS VIDE INSTRUCTIONS D'OPÉRATIONS

## TABLE DES MATIÈRES

1. Mise en marche de la machine
2. Connexion Électrique
3. Opération
  - 3.1 Principes de travail
  - 3.2 Emballage Spécial
    - 3.2.1 Injection de Gaz
    - 3.2.2 Scellage haut et bas  
(bi-active sealing)
    - 3.2.3 Coupe sac électrique
  - 3.3 Ajustement des contrôles digital
  - 3.4 Nettoyage Quotidien
4. Trouble de lancement
  - 4.1 Échec durant le cycle d'emballage
  - 4.2 Vide insuffisant
    - 4.2.1 Fuites dans le sac
    - 4.2.2 Pas de fuite dans le sac
    - 4.2.3 Vide insuffisant dans la chambre
  - 4.3 Scellage Inadéquat
    - 4.3.1 Scellage insuffisant
    - 4.3.2 Pas de scellage
    - 4.3.3 Courant ininterrompu sur les barres de scellage
    - 4.3.4 Le scellage ne tient pas
  - 4.4 Problème avec les valves
  - 4.5 Problème du panneau de contrôle
5. Maintenance Régulière

# SIPROMAC INC. EMBALLÉUSES SOUS VIDE

## 1. MISE EN PLACE DE LA MACHINE:

Avant de choisir le site d'installation de votre machine, veuillez considérer que vous aurez besoin d'espace pour les produits emballés et non-emballés à part de l'espace occupé par la machine elle-même.

Bien vouloir vous rappelez que vous aurez besoin d'un sol bien au niveau pour votre installation. Spécialement avec les modèles mobiles, le poids de la pompe peut gauchir la machine et le couvercle ne fermera plus correctement.

Avant de commencer à travailler, vérifier l'huile de la pompe pour voir si elle est en quantité suffisante. Bien vouloir ne jamais utiliser une huile autre que celle recommandée par le fabricant. Ne pas excéder la quantité indiquée quand vous ajoutez ou faites le changement d'huile et faites votre vérification hebdomadairement.

En raison de la viscosité de l'huile, la machine sera plus difficile à démarrer à basses températures. Ainsi donc la pompe doit être placée dans un endroit où la température est d'au moins 50°F (+10°C). D'autre part, l'air doit circuler librement aux alentours de la pompe pour permettre le refroidissement dans les cas où la température des opérations atteindrait 160°F (70°C) ou la température maximale permise.

## 2. CONNEXION ÉLECTRIQUE:

Les connexions électriques doivent se faire par du personnel qualifié. La personne désignée doit s'assurer que les entrées électriques correspondent au voltage et à l'ampérage approprié de la machine.

Un schéma électrique accompagne chacune de nos machines.

Une étape importante dans le branchement de la machine est de s'assurer que le moteur de la pompe tourne dans une rotation appropriée.

Attention: Le moteur de la pompe ne devrait pas tourner plus de 3 ou 4 secondes dans une mauvaise rotation car il en résultera des dommages sérieux. La rotation est indiquée par une flèche sur le moteur de la pompe.

## 3. OPÉRATION:

### 3.1 Principes de travail:

Un emballage sous vide est un cycle composé de 3 étapes. Premièrement le vide est fait et l'air est complètement enlevé de la chambre et du sac contenant le produit. (Voir figure 1). Ensuite c'est possible d'injecter du gaz neutre par les conduits si le produit est très délicat. Finalement, un mécanisme pousse la barre de scellage sur le support de caoutchouc pour sceller le sac

Pour obtenir de beaux emballages, les produits et les sacs doivent être de taille proportionnelles. L'ouverture du sac ne devrait jamais excéder 2" (50cm) au delà des barres de scellage. Le produit doit être centré en hauteur par rapport aux barres de scellage en ajustant les écarteurs qui vous sont fournis.

Pour obtenir un bon scellage, assurez-vous qu'il n'y a pas de résidu de graisse qui reste entre les côtés intérieurs des sacs où le scellage doit être fait.

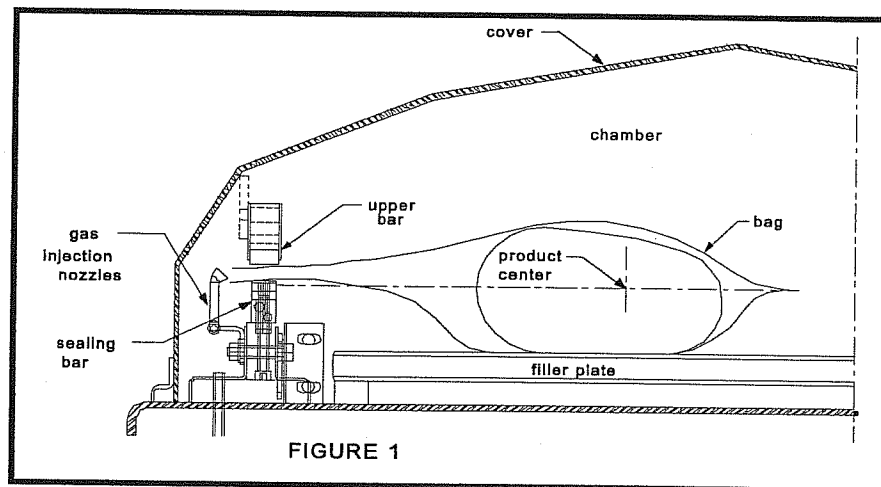

### 3.2 Emballage Spécial:

#### 3.2.1 Injection de Gaz (option):

Il y a une pression atmosphérique de 14 lbs / pouce carré (= 1 kg / cm carré) sur les produits quand le vide demandé est atteint. Les produits qui peuvent être endommagés par une haute pression doivent être emballés avec un vide partiel et la pression doit être contrebalancée en injectant du gaz dans le sac (nitrogène ou dioxyde de carbone) avant le scellement et après avoir atteint le vide.

Pour l'injection de gaz, les sacs sont placés sur les barres de scellage, l'ouverture placée au-dessus des conduits de gaz qui sont montés le long des barres de scellage. Après que le vide soit atteint, la valve du vide se ferme et la valve du gaz s'ouvre. Le pourcentage de gaz peut être ajusté par le menu du programme.

Le réservoir de gaz et la valve de pression qui est rattachée au réservoir ne sont pas fournis par Sipromac. La pression pour le régulateur de gaz devrait être ajustée approximativement à 5 lbs/pouce carré (1/3 Kg/cm carré). Chaque machine a un adaptateur pour la connexion de gaz quand l'option de l'injection de gaz est commandée.

#### 3.2.2 Scellage Haut et Bas (optionnel):

Pour le scellage des sacs en aluminium comme pour le café il est impératif d'avoir une barre de scellage en haut et en bas.

#### 3.2.3 Coupe sac électrique: (optionnel):

Cette option est utilisée pour obtenir un paquet dont l'excédent de film au niveau du scellage doit être coupée très près de la ligne de scellage. ( cette option ne peut pas être utilisée avec le scellage Haut et Bas)

### 3.3 Les opérations de l'emballage sous vide:

Note: Reportez-vous aux menus structure de la page 8 et aux détails du panneau de contrôle sur la page 9

#### 3.3.1 Bases:

Utilisez la touche "POWER" pour initier le bouton ON/OFF sur votre machine sous vide. Quand votre unité sera en fonction le dernier programme exécuté apparaîtra sur l'écran à cristaux liquides.

Utilisez la touche "ESC" pour passer du menu programme au menu fonctions et du menu des fonctions au menu des programmes.

Dans le menu des fonctions, utilisez la touche "SELECT" pour sélectionner une fonction et la touche "ENTER" pour exécuter la sélection.

Dans le menu des programmes, utilisez la touche "SELECT" pour sélectionner un programme et la touche "Enter" pour accéder ou modifier la sélection.

Dans les programmes du sous menu, utilisez la touche "ENTER" pour voir défiler les paramètres et lorsque ces derniers clignotent pour indiquer ils sont dans le mode d'acquisition. Quand la séquence de tous les paramètres se sont affichés, on revient automatiquement au début de la liste.

Dans les programmes du sous menu, utilisez la touche "ESC" pour revenir au menu des programmes. Pressez n'importe quelle touche pour effacer les messages d'erreur qui peuvent s'afficher sur l'écran à cristaux liquide.

#### 3.3.2 Menu des fonctions:

##### 3.3.2.1 Créer un programme:

Quand vous exécutez la fonction "create a program", le programme sous menu est atteint en commençant par l'identification. L'identification initiale "PxxNO NAME" est donné au programme et tous les paramètres sont établis à zéro; le numéro du programme est alloué automatiquement.

##### 3.3.2.2 Supprimer un programme:

En exécutant la fonction de "delete a program", vous avez accès au menu des programmes et le numéro du premier programme en mémoire clignote pour indiquer le mode de suppression. Utilisez la touche "SELECT" pour sélectionner un programme et la touche "ENTER" pour avoir accès et confirmer la suppression de la sélection. Utilisez la touche "ESC" pour annuler une suppression et quitter la fonction. Quand vous quittez la fonction, le nombre des programmes actuels sur l'écran à cristaux liquides cesse de clignoter.

##### 3.3.2.3 Choisir le mode d'opération:

Quand vous exécutez la fonction "Select Operating Mode", laquelle est disponible seulement pour les unités automatiques, la sélection en cours clignote pour vous indiquez le mode. Utilisez la touche "SELECT" pour parcourir les modes d'opération, lesquels sont automatiques, semi-automatiques et manuels.

Le mode d'opération sera validé et exécuté automatiquement. Utilisez la touche "ESC" ou "ENTER" pour quitter la fonction et retourner au menu des programmes.

### 3.3.3 Menu des Programmes:

#### 3.3.3.1 Identification des Programmes:

Pour un programme sélectionné, choisissez l'identification en utilisant le panneau de contrôle numérique avec la chartre des caractères et pressez sur la touche numérique jusqu'à ce que le caractère soit sélectionné (4 x pour la valeur numérique). Utilisez la touche "ENTER" pour valider le caractère ainsi que la chaîne de caractères jusqu'à la fin ( la nouvelle chaîne de caractères clignote). Vous pouvez utiliser la touche "ESC" pour revenir en arrière dans le cas où vous vous êtes trompé et que vous voulez effacer le caractère.

Example: EXAMPLE 1 → (9 caractères)

Touche 2, 2, ENTER	→ E
Touche 8, 8, 8, ENTER	→ X
Touche 1, ENTER	→ A
Touche 5, ENTER	→ M
Touche 6, ENTER	→ P
Touche 4, 4, 4, ENTER	→ L
Touche 2, 2, ENTER	→ E
Touche 9, 9, 9, ENTER	→ espace
Touche 1, 1, 1, 1, ENTER	→ 1

Touche ENTER pour valider la chaîne de caractères

#### 3.3.3.2 L'ajustement du niveau de Vide (capteur de vide désactivé):

Pour un programme sélectionné, ajustez le niveau de vide, en secondes; la validation est automatiquement exécutée après la deuxième entrée digitale ( Le nouveau temps de vide clignote). En cours de traitement, utilisez la touche "ENTER" pour valider la valeur du niveau de vide et la touche "ESC" pour revenir en arrière et changer la valeur du niveau de vide ( La valeur du niveau de vide la plus ancienne clignotera à ce moment).

Exemples: 1 sec. → Touches 0, 1 ou 1, ENTER  
15 sec. → Touches 1, 5

#### 3.3.3.3 L'ajustement du niveau de Vide (capteur de vide en activé):

Pour un programme sélectionné, ajustez le niveau de vide avec les valeurs; le point décimal est automatiquement inséré suivant la deuxième entrée digitale et la validation est automatiquement exécutée après la troisième entrée digitale ( La nouvelle valeur du niveau du vide clignote). Le niveau de vide est arrondi à la demie la plus près de la valeur. En cours de traitement, utilisez la touche "ENTER" pour valider la valeur du niveau de vide et la touche "ESC" pour revenir en arrière et changer la valeur du niveau de vide ( La valeur du niveau de vide la plus ancienne clignotera à ce moment). Ajustez le niveau du vide à zéro pour pouvoir contourner le capteur de vide et procédez en réglant seulement le " Temps de vide Plus" (Vacuum plus time).

Exemples: 90.0% → Touches 9, 0, 0 ou 9, 0, ENTER ou  
Touches 9, 0, 1 ou 9, 0, 2 or 9, 0, 3 ou 9, 0, 4  
97.5% → Touches 9, 7, 5 ou  
Touches 9, 7, 6 ou 9, 0, 7 or 9, 0, 8 ou 9, 0, 9  
0.0% → Touches 0, 0, 0 ou 0, ENTER

#### 3.3.3.4 Ajustement du Temps de Vide "Plus" (capteur de vide activé):

Pour un programme sélectionné, réglez le "temps de vide plus" en secondes; la validation est automatiquement exécutée après la deuxième entrée digitale ( La nouvelle valeur du "temps de vide plus" clignotera à ce moment). En cours de traitement, utilisez la touche "ENTER" pour valider la nouvelle valeur du "temps de vide plus" et la touche "ESC" pour revenir et recommencer avec de nouvelles valeurs ( la valeur la plus ancienne du "temps de vacuum plus" clignotera).

Exemples: 1s → Touche 0, 1 or 1, ENTER  
15s → Touche 1, 5

#### 3.3.3.5 Ajustement de l'injection de gaz (capteur de vide désactivé):

Pour sélectionner un programme placer le niveau d'injection de gaz en suivant la même procédure que pour le niveau de vide. Gardez en mémoire que plus le temps d'injection de gaz est haut, moins la pression du sellage sera forte. Un certain niveau de vide doit être maintenu pour un bon fonctionnement.

#### 3.3.3.6 Ajustement de l'injection de gaz (capteur de vide activé):

Pour sélectionner un programme placer le niveau d'injection de gaz en suivant la même procédure que pour le niveau de vide; L'ajustement pour le gaz le plus haut devrait être de 10% au-dessous du niveau de l'ajustement de vide.

#### 3.3.3.7 Ajustement du cachetage:

Pour sélectionner un programme le temps de cachetage, en commençant par les secondes; le point décimale est automatiquement insérée après la première entrée de chiffre et la validation est automatiquement effectuée après la troisième entrée de chiffre (le nouveau temps de cachetage clignote). Le temps de cachetage est arrondi à la moitié la plus proche du cent. À un milieu l'entrée des données, utiliser la clé "ENTER" pour valider l'heure du cachetage et la clé " ESC " pour revenir en arrière et reprogrammer le temps cachetage avec de nouvelles données (le vieux temps de cachetage clignote).

Exemples: 4.50s → clés 4, 5, 0 or 4, 5, ENTER or  
clés 4, 5, 1 or 4, 5, 2 or 4, 5, 3 or 4, 5, 4  
2.35s → clés 2, 3, 5 or  
clés 2, 3, 6 or 2, 3, 7 or 2, 3, 8 or 2, 3, 9  
0.00s → clés 0, 0, 0 or 0, ENTER

### 3.3.4 Exécution de cycle de vide :

Pour les unités manuels ainsi que les unités automatiques faire la mise en marche manuelle, fermer le couvercle afin de lancer un cycle de vide. Pour l'unité automatique faire mise en marche semi-automatique ou automatique, utilisez le bouton "ARRÊT / DÉBUT" pour lancer ou interrompre un cycle de vide. Le programme sélectionné peut être lancé seulement dans le programme du menu, au moment où aucune modification n'est nécessaire, et l'accès des autres programmes et des fonctions ne sont pas requis. Pendant l'exécution du cycle le statut d'opération est séquentiellement affiché sur l'écran à cristaux liquides, excepté pour les paramètres établis à zéro, qui ne sont pas montrés:

- niveau de vide de la chambre pendant la séquence,
- vide additionné du temps pendant le vide plus la séquence,
- niveau de vide de la chambre pendant la séquence d'injection de gaz,
- statut de temps de cachetage pendant la séquence de cachetage,
- niveau de vide de la chambre pendant La séquence d'atmosphère .7

Pendant l'exécution du cycle, utilisé la clef "1" pour interrompre la séquence de vide et pour exécuter la séquence suivante, soit l'injection du gaz ou le cachetage, suivi de la clé "ENTER" afin d'accéder et modifier le programme; les paramètres deviennent valides seulement pour les cycles suivants de vide.

### 3.3.5 System monitor:

Pour accéder le menu des diagnostics, monter la puissance de la machine d'emballage sous vide tout en maintenant le bouton "ESC" enfoncé. Utilisez la clé "SELECT" pour choisir la fonction du système du moniteur et "ENTER" pour accéder et visualiser les paramètres surveillés. Employez la clé "SELECT" pour changer la révision de logiciel, la quantité d'heures de travail faites et de la quantité de cycles complets exécutés depuis la première initialisation.



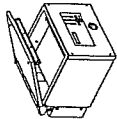

250

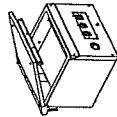

300

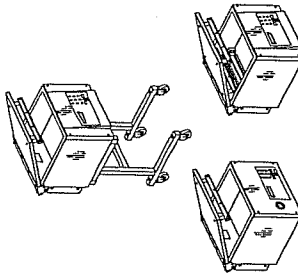

350/350D

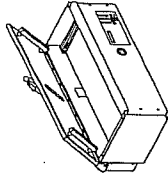

380A

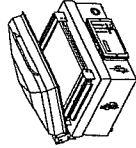

450T

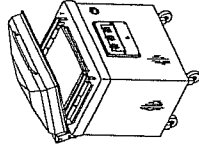

400A

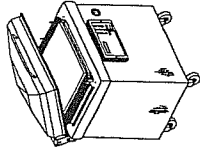

450A

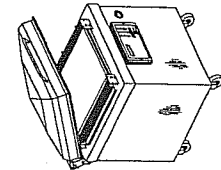

550A

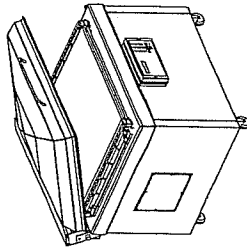

580A

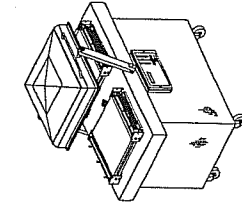

420A

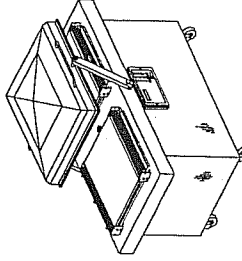

600A

VACUUM PACKAGING MACHINES

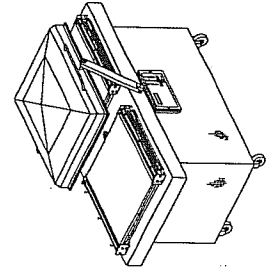

620A

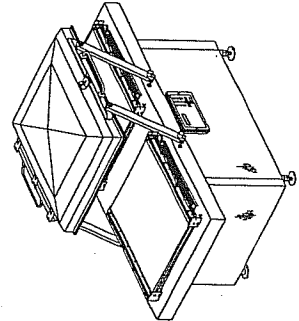

650A

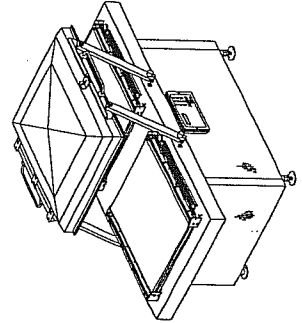

680A

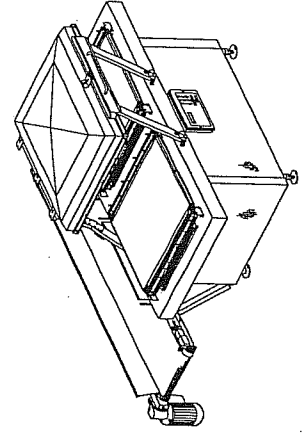

700A

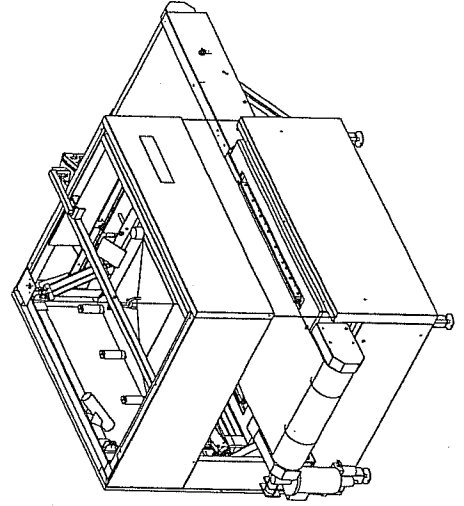

750A