



OWNER'S MANUAL

VACCUM MACHINE
420A

IMPORTANT SAFETY INSTRUCTIONS

SAVE THESE INSTRUCTIONS



This symbol points out important safety instructions which, if not followed, could endanger the personal safety and/or property of yourself and others. Read and follow all instructions in this manual before attempting to operate your machine.

Failure to comply with these instructions may result in personal injury.

General Operation

- Read, understand, and follow all instructions in the manual and on the machine before starting. Keep this manual in a safe place for further and regular reference and for ordering replacement parts.
- Only allow responsible individuals familiar with the instructions to operate the machine. Be sure to know controls and how to stop the machine quickly.
- Never put your hands near moving parts.
- Only allow qualified individuals for the maintenance of your machine.
- Remove all obstacles, which may interfere with the machine functions.
- Clear the work area such as electrical wires, buckets, knives etc.
- Be sure that everyone else is clear of your work area before operating the machine.
- Do not sit nor stand on the machine.
- Always turn off the machine after your work is done. Never leave a running machine unattended.
- Always disconnect and wait till the machine has cooled before attempting any maintenance.
- Do not wear loose fitting clothes or jewelry as they may get caught in moving parts of the machine.
- Always wear security shoes, to prevent injury caused by moving the machine or objects falling from the machine.
- Never exceed the time limit to seal, which is recommended by the manufacturer. This is to avoid any damage that may be caused to the sealing bars and to eliminate the risk of fire in the machine. Thus avoiding corporal burns.
- Never touch the sealing bars after they have been used, this will avoid corporal burns. Wait a few minutes to let the machine cool down before touching.
- Always make sure that the sealing bars are well installed in their "Guide Blocks" before starting a cycle.
- Never incline the machine more than 30 degrees, it may tip over and hurt someone seriously.
- Work only in daylight or good artificial light.

Do not operate the machine while under the influence of alcohol or drugs!

Service

- Use proper containers when draining the oil. Do not use food or beverage containers that may mislead someone into drinking from them. Properly dispose of the containers, or store in a safe place immediately following the draining of the oil.
- Prior to disposal, determine the proper method to dispose of waste from your local office of Environmental Protection Agency. Recycling centers are established to properly dispose of materials in an environmentally safe fashion.

Do not pour oil or other fluids into the ground, down a drain or into a body of water.



Warning-Your responsibility:

This machine should only be operated by personal who can read, understand and respect warnings and instructions regarding this machine in the owners manual. Save these instructions for future reference.

VACUUM PACKAGING MACHINE

MODEL 420A

(MC-40 SIPROMAC)

GENERAL TABLE OF CONTENTS

I OPERATION INSTRUCTIONS

II MECHANICAL

- A- Front view general assembly drawing
- B- Rear view general assembly drawing
- C- Cover adjustment procedure
- D- Central shaft assembly drawing
- E- Seal bar assembly drawings
(twin seal)
- F- Seal bar assembly drawings
(electrical bag cut option)
- G- Seal bar assembly drawings
(top and bottom sealing option)
- H- Gas injection kit installation drawing
(gas injection option)

III ELECTRICAL

- A- Electrical drawings

IV PNEUMATIC

- A- Pneumatic drawing

VACUUM PACKAGING MACHINES

OPERATION INSTRUCTIONS

TABLE OF CONTENTS

1. Setting up the machine
2. Electrical connection
3. Operation
 - 3.1 Working principles
 - 3.2 Special packaging
 - 3.2.1 Gas flushing
 - 3.2.2 Top and bottom sealing (bi-active)
 - 3.2.2 3.2.3 Electrical bag cut
 - 3.3 Setting of digital controls
 - 3.4 Daily cleaning
4. Trouble shooting
 - 4.1 Failure during a packaging cycle
 - 4.2 Insufficient vacuum
 - 4.2.1 Leakage in the bag
 - 4.2.2 No leakage in the bag
 - 4.2.3 Insufficient vacuum in the chamber
 - 4.3 Faulty seal
 - 4.3.1 Insufficient seal
 - 4.3.2 No seal
 - 4.3.3 Permanent sealing current
 - 4.3.4 Seal does not stick
 - 4.4 Fault in the valves
 - 4.5 Control board failure
5. Regular maintenance

2010-08-30

SIPROMAC INC.

VACUUM PACKAGING MACHINES

1. SETTING UP THE MACHINE:

Before choosing the site for the machine, please consider that you will also need room for packaged and non-packaged products apart from the space needed for the machine itself.

Keep in mind that the machine must not be set up upon uneven ground. Especially with mobile models, the weight of the pump might then cause warping of the machine. Then the lid will not fit correctly.

Before starting to work, check the oil view glass on the pump, if there is a sufficient quantity of oil in the pump. Never use oil other than recommended by the producer. Never exceed maximum quantity of oil indicated, when adding or changing oil. Verify weekly.

Normal ambient temperature for the vacuum pump is between 10 to 70°C. For temperature below 10°C; it is recommended to use synthetic oil. Please consult factory and pump manufacturer manual for more information or when ambient temperature are outside normal limits

2. ELECTRICAL CONNECTION:

Electrical connections must be made by qualified personnel. This person must make sure that the electrical entries corresponds to the proper voltage and amperage of the machine. **GROUNDING INSTRUCTIONS:** This appliance must be connected to a grounded, metal, permanent wiring system; or an equipment-grounding conductor must be run with the circuit conductors and connected to the equipment-grounding terminal or lead on the appliance. A qualified electrician should be consulted if there is any doubt as to whether an outlet box is properly grounded.

All vacuum machines are supplied with an electrical schematic drawing. An important step in connecting the machine is to make sure that the pump turns in its correct rotation.



The pump should not rotate more than 3 to 4 seconds in the wrong rotation or it may cause serious damage. The proper rotation is indicated by an arrow on the pump motor.

3. OPERATION:

3.1 Working principles:

A vacuum packaging cycle is made of 3 stages. First the vacuum is made, the air is completely taken out of the chamber and from bag containing the product. (See figure 1). Then it is possible to inject neutral gas from the nozzles, if the product is delicate. Finally, a mechanism pushes the sealing bar to the rubber support to seal the bag.

To obtain nice packages, the products and the bags have to be of proportional sizes. The bag's opening should never exceed 50 cm(2") past the seal bars. The product should be centered in height in relation to the seal bar by adjusting the spacers provided.

To obtain a good seal, make sure that no residue of fat is left between the bag's inner sides where sealing is done.

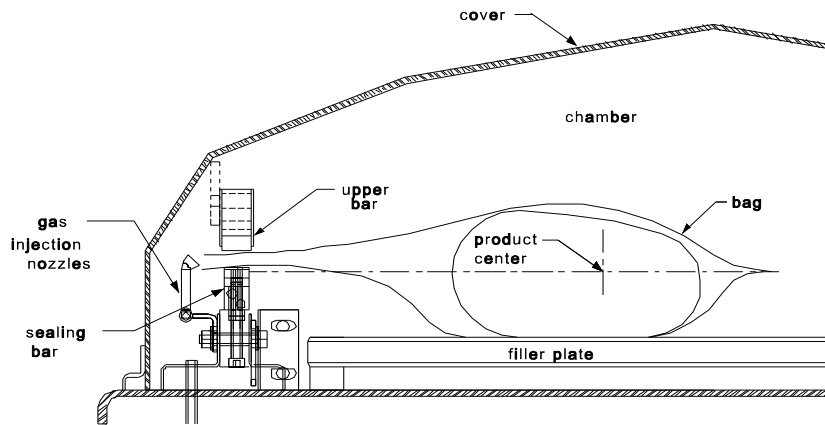

FIGURE 1

3.2 Special packaging:

3.2.1 Gas flushing (option):

There is an atmospheric pressure of 1 kg/ sq. cm (14 lbs/sq. inch) upon products when fully evacuated. Products which can be damaged by high pressure must be packaged with a partial vacuum, or the pressure must be counterbalance by inflating the bag with gas (nitrogen or carbon dioxide) before sealing after evacuation.

For gas flushing, the bags are placed on the sealing bars, the open end placed over the gas nozzles mounted alongside the sealing bar. After evacuation, the vacuum valve closes and the gas valve opens. Gas time (sec.) can be set in the program menu.

The necessary gas tank and pressure valve mounted on tank is not supplied, The pressure of the gas regulator should be set at approximately 1/3 kg/sq. cm (5 lbs/sq.inch.). Each machine has an adaptor for gas connection when gas flush option is ordered.

3.2.2 Top and bottom sealing (optional):

When sealing aluminium laminate bags (especially bags for e.g. coffee) it is imperative to have an upper and a lower sealing bar.

3.2.2 Electrical bag cut (optional):

This option is used to obtain a package that the excess bagtail is cut off close to the seal (cannot be used with top and bottom sealing).

3.3 Vacuum packaging operation:

3.3 Vacuum packaging operation:

Note: Refer to the menus structure on page 14 and the keyboard detail on page 15.

3.3.1 Basics:

Use key "POWER" to power ON / OFF the vacuum packaging machine. When the unit is energized, the identification of the last executed program is displayed on LCD screen.

Use the "ESC" key to change over from the programs menu to the functions menu and from the functions menu to the programs menu.

In functions menu, use key "SELECT" to select a function and key "ENTER" to accede and executed the selection.

In programs menu, use key "SELECT" to select a program and key "ENTER" to accede and modify the selection.

In programs submenu, use key "ENTER" to pass over the parameters and point to the following one; the parameters are blinking to point out the acquisition mode. A return to programs menu is performed automatically following the last parameter acquisition.

In program submenu, use key "ESC" to get back to the programs menu. Strike any key to clear the error messages which may be displayed on LCD screen.

3.3.2 Functions:

3.3.2.1 Create a program:

When executing the "create a program" function, the program submenu is acceded, starting with the identification. The initial identification "Pxx NO NAME" is given to the program and all parameters are established to zero; the program number is allocated automatically.

3.3.2.2 Delete a program:

When executing the "delete a program" function, the programs menu is acceded and the number of the first program in memory is blinking to point out the deletion mode. Use key "SELECT" to select a program and key "ENTER" to accede and confirm deletion of the selection. Use key "ESC" to unconfirm a deletion and to leave the function. When leaving the function, the number of the actual program on LCD screen cease to blink.

3.3.2.3 Select operating mode:

When executing the "select operating mode" function, which is available only for the automatic units, the actual selection is blinking to point out the acquisition mode. Use key "SELECT" to get through the operating modes, which are automatic, semi-automatic and manual; the validation of the selected operating mode is performed automatically. Use key "ESC" or "ENTER" to leave the function and get back to the program menu.

3.3.3 Programs menu:

3.3.3.1 Program identification:

For a selected program, set the identification, using the numeric keyboard characters chart; press numeric key until the desired character is selected (4 times for the numeric value). Use key "ENTER" to validate the character and to validate the characters string at the end (the new characters string is blinking). In a middle of an acquisition, use key "ESC" to come backward and erase one or several characters.

Example: EXAMPLE 1 → (9 characters)

keys 2, 2, ENTER	→ E
keys 8, 8, 8, ENTER	→ X
keys 1, ENTER	→ A
keys 5, ENTER	→ M
keys 6, ENTER	→ P
keys 4, 4, 4, ENTER	→ L
keys 2, 2, ENTER	→ E
keys 9, 9, 9, ENTER	→ space
keys 1, 1, 1, 1, ENTER	→ 1

key ENTER to validate the characters string

3.3.3.2 Vacuum level setting:

For a selected program set the vacuum level, starting with the values; the decimal point is automatically inserted following the second digit entry and the validation is automatically performed following the third digit entry (the new vacuum level is blinking). The vacuum level is rounded off to the nearest half value. In the middle of an acquisition, use key "ENTER" to validate the vacuum level and key "ESC" to come backward and start over with a new acquisition (the old vacuum level is blinking). Set vacuum level to zero to bypass the pressure transducer and proceed only using the vacuum plus time.

Examples: 90.0% → keys 9, 0, 0 or 9, 0, ENTER or
keys 9, 0, 1 or 9, 0, 2 or 9, 0, 3 or 9, 0, 4
97.5% → keys 9, 7, 5 or
keys 9, 7, 6 or 9, 0, 7 or 9, 0, 8 or 9, 0, 9
0.0% → keys 0, 0, 0 or 0, ENTER

3.3.3.3 Vacuum plus time setting:

For a selected program set the vacuum plus time, in seconds; the validation is automatically performed following the second digit entry (the new vacuum plus time is blinking). In a middle of an acquisition, use key "ENTER" to validate the vacuum plus time and key "ESC" to come backward and start over with a new acquisition (the old vacuum plus time is blinking).

Examples: 1s → keys 0, 1 or 1, ENTER
15s → keys 1, 5

3.3.3.4 Gas flush level setting:

For a selected program set the gas flush level following the same procedure as for the vacuum level; the maximum gas flush level setting is 10% below the vacuum setting.

3.3.3.5 Sealing time setting:

For a selected program set the sealing time, starting with the seconds; the decimal point is automatically inserted following the first digit entry and the validation is automatically performed following the third digit entry (the new sealing time is blinking). The sealing time is truncated to the nearest half hundredth. In a middle of an acquisition, use key "ENTER" to validate the sealing time and key "ESC" to come backward and start over with a new acquisition (the old sealing time is blinking).

Examples: 4.50s → keys 4, 5, 0 or 4, 5, ENTER or
keys 4, 5, 1 or 4, 5, 2 or 4, 5, 3 or 4, 5, 4
2.35s → keys 2, 3, 5 or
keys 2, 3, 6 or 2, 3, 7 or 2, 3, 8 or 2, 3, 9
0.00s → keys 0, 0, 0 or 0, ENTER

3.3.4 Vacuum cycle execution:

For the manual units and the automatic units set on manual, close the cover to initiate a vacuum cycle. For the automatic units set on semi-automatic or on automatic, use push button "STOP / START" to initiate or interrupt a vacuum cycle. A selected program can be initiated only in the programs menu, when no modifications are in progress, and the access to the other programs and functions is denied. During cycle execution the operation status is sequentially displayed on LCD screen, except for the parameters established to zero, which are not displayed:

- chamber vacuum level during vacuum sequence,
- vacuum plus time status during vacuum plus sequence,
- chamber vacuum level during gas flush sequence,
- sealing time status during sealing sequence,
- chamber vacuum level during atmosphere sequence.

During cycle execution, use key "1" to abort the vacuum sequence and execute the following sequence, which is gas flush or sealing, and key "ENTER" to accede and modify the program; the parameters become valid only for the following vacuum cycles.

3.3.5 System monitor:

To accede the diagnostics menu, power up the vacuum packaging machine while keeping pushed in the "ESC"key. Use key "SELECT" to select the system monitor function and key "ENTER" to accede and visualize the monitored parameters. Use key "SELECT" to change over from the software revision, the amount of working hours done and the amount of complete cycles performed since first initialization.

-MENUS STRUCTURE-

- **Functions menu:**
 - "F1 CREATE A PRGM"
 - "F2 DELETE A PRGM"
 - "F3 SELECT OPMODE" (automatic units only)
- **Programs menu:**
 - "Pxx NAME"
 - Program submenu:
 - "VACUUM: xx.x%" (10.0% - 99.5%)
 - "VACUUM PLUS: xxs"(0s - 99s)
 - "GAS FLUSH: xx.x%" (0.0% - 10% below the vacuum level) (units with gas option)
 - "SEAL TIME: x.xxs" (0.00s - maximum unit allocated setting)
 - "Pxx NAME" (12 characters)
- **Diagnostics menu** (keys "ESC" & "POWER" for access):
 - "DIAGNOSTICS MENU" (access code required)
 - "D1 INPUTS TEST"
 - "D2 OUTPUTS TEST"
 - "D3 MODEL SELECT"
 - "D4 GAS OPTION"
 - "D5 SEALING TIME"
 - "D6 COOLING TIME"
 - "D7 OFFSET CALIB."
 - "D8 VACUUM SENSOR"
 - "D9 SIPROMAC PUB"
 - "D10 LOADING TIME" (automatic units only)
 - "D11 UNLOADNG TIME" (automatic units only)
 - "SYSTEM MONITOR" (no access code required)
 - "SOFTWARE: R x.xx"
 - "WORK HRS: xxxxx"
 - "CYCLES: xxxxxxxx"

-KEYBOARD DETAILS-

MC-40 CONTROLS

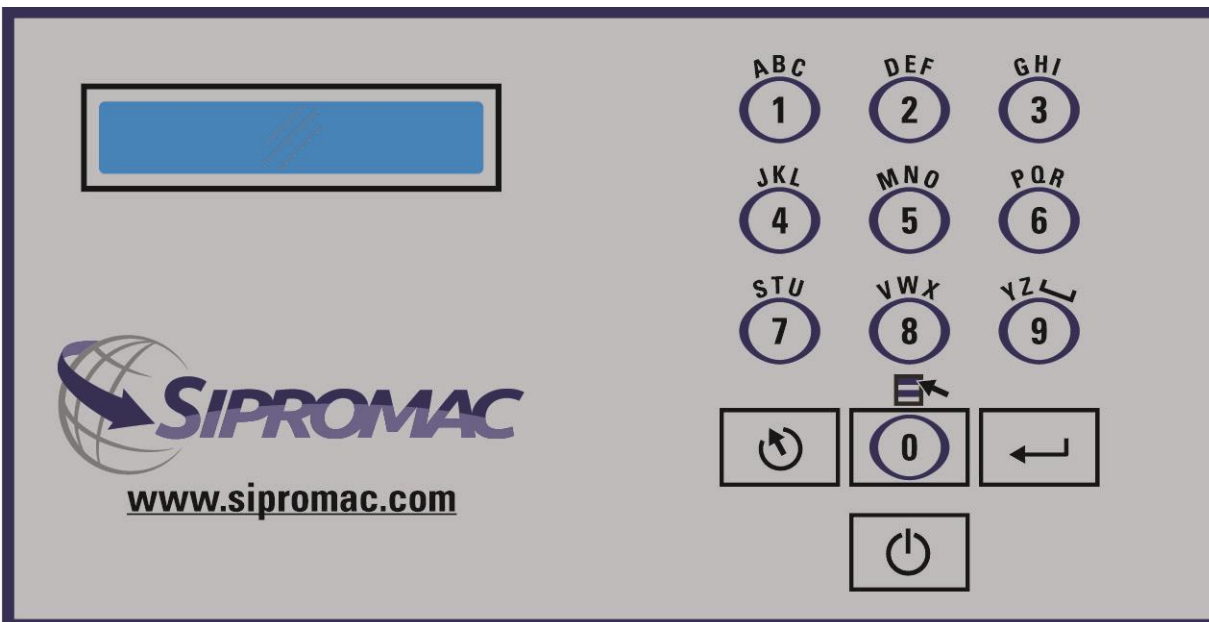



WARNING: All electrical work described in this brochure should be done by a QUALIFIED and AUTHORIZED technician.

3.4 Daily cleaning:

For hygienic cleanliness, it is imperative to clean chamber and spacers daily. Also clean the lid rubber to assure tight seat of the lid.

Cleaning instructions for gas injection nozzles: Periodically on a regular basis the gas injection nozzles must be removed with the connection tube and soaked in a food grade soap and water solution, then dried and re-installed.

4. TROUBLE SHOOTING:

4.1 Failure during packaging cycle:

4.1.1 "VACUUM ERROR" message is displayed on LCD:

No pressure variation is picked up by the PCB transducer during the vacuum sequence within a preset period of time.

- Check vacuum lines for potential leaks or kinks.

4.1.2 "GAS FLUSH ERROR" message is displayed on LCD:

No pressure variation is picked up by the PCB transducer during the gas flush sequence within a preset period of time.

- Check gas flush and vacuum lines for potential leaks or kinks.

4.1.3 "ATMOSPHERE ERROR" message is displayed on LCD:

No pressure variation is picked up by the PCB transducer during the atmosphere sequence within a preset period of time.

- Check vacuum lines for potential leaks or kinks.

4.1.4 "COVER DOWN ERROR" message is displayed on LCD(manual units):

The input signal of the down position switch has been lost during cycle execution.

- Check limit switch adjustment.

4.2 Insufficient vacuum:

4.2.1 Leakage in the bag:

Most frequently, insufficient vacuum in bags is due to leakage in bag and not due to any fault of the machine.

Pin-hole leak for which there is no obvious explanation is due to faulty bag material.

Pin-hole leak caused by sharp edge of the product (bone, etc.). Use bone-guard or thicker film.

Tear in bag by careless handling (sharp edge on filling table, damage made by retailer or customer).

Leakage in lateral or bottom seal, complain to supplier of bags or film.

4.2.2 No leakage in the bag:

Bag is too large, therefore the surplus of air remains visible (there is surplus of air in 0.4% of the bag volume in each bag). Use bags of suitable size.

Vacuum level is too low:

Pressure bar is jammed and closes opening of bag during evacuation.

4.2.3 Insufficient vacuum in chamber:

If troubles described under 4.2.1 and 4.2.2 do not apply, there is something wrong with the evacuation. To find the leakage quickly, check for leaks with a precision vacuumeter, going back step by step from the chamber to the pump.

At the chamber (measuring point at base of valve) at maximum time of evacuation. If more than 6 torr, proceed directly to the pump, if more than 3 torr: have pump service by pump supplier. If pressure at pump is good, reconnect hoses to pump and measure again.

Verify at vacuum hose connections and valve connections.

When proceeding this way, starting from pump, loss of pressure per step must not exceed 0.5 to 1 torr.

Caution: Verify connections of measuring equipment before verifying machine.

Most frequent points of leakage: lid gasket, damaged vacuum hose or loose hose clamps.

4.3 Faulty seal:

4.3.1 Insufficient seal:

Damaged teflon or silicone rubber.

Sealing pressure too low, bellows leaking or pressure bar jammed.

Leakers in seal: heating wire mechanically damaged (knicked) or silicone rubber uneven.

4.3.2 No seal:

Sealing wire burnt.

Faulty contact in sealing circuit.

Sealing transformer burnt through.

Contactors does not work.

4.3.3 Permanent sealing current:

Contactors is jammed check sealing transformer for damage through overload.

4.3.4 Seal does not stick:

Insufficient layer of polyethylene (inferior quality of bags).

Seal area extremely contaminated by fat or meat juice. Use filling aid.

Sealing temperature is too low (when using very thick films).

Caution: Do not increase sealing time more than really necessary; higher temperature will reduce working life of teflon and silicone rubber.

4.4 Fault in the valve:

Vacuum or air valve does not open.

Check whether there is voltage on the magnetic valves during their period of operation. If there is no voltage a wire is broken or the PC board is damaged.

Lid does not open at the end of the cycle; air enters, but there is still 20 - 40% vacuum in chamber. Vacuum valve does not close.

4.5 MC40 Control board failure

NOTE: Refer to menu structure on page 13.

This board software is allowing access to a "Diagnostics Menu". Only qualified service technicians are authorized to access this menu by entering a security password.

By acceding either the "D1 input test" feature or the "D2 output test" feature, a trained technician will be able to quickly know the origin of the problem: pump, sealing system, pneumatic problem, security switches problem, etc...

Keep in mind that in most cases trouble is due to a leakage, loose electrical connection or evident damage to the main components: vacuum pump, valves, electrical contactors, thermal overload, fuses holder or transformer.

For assistance do not hesitate to contact your local service technicians.

5. Regular maintenance:

Routine controls to be made at regular intervals:

Check teflon for wear.

Check silicone rubber for burnt spots and smooth even position.

Check pressure bar for jamming.

Check lid sealing for damage and hardened spots.

Check switch-point of micro switch, adjust if necessary.

Check evacuation hose for damage (contraction of diameter, or abrasions).

Check vacuum connections for tightness.

Check oil in pump (oil level in view glass; add if necessary. Regular change of oil - necessity indicated by change of color).

Check vacuum in chamber with precision vacuumeter.

Check function of cycle with various settings of timers.

MODEL 420A

COVER ADJUSTMENT PROCEDURE

Reference Drawing:# 005B0598
004B0124

PROBLEM: MACHINE TABLE AND COVER SEEMS TO BE STRAIGHT, LID GASKET IS GOOD BUT COVER DOES NOT SIT PROPERLY ON BOTH SIDES OF TABLE.

1. Floor should be flat (within 1/8" approx.).
 - 2.2 Loosen the two bolts of the guide arm axis (See drawing #004B0124; items #19).
 - 2.3 Now move the cover on each side and check how cover sits on the table. Distance between table and lid gasket should be less than 1/16" approx. If so, go to step 3.0 for guide arm adjustment. Otherwise go to step 2.4 for central arm adjustment.
 - 2.5 When closing cover (guide arm axis still loose), if cover is not sitting properly on either the front or rear of the table, you have to change the height of the flange bearings (See drawing # 004B0124; item #27) until cover is seating properly on each side. Normally shaft is centered in the table holes and the height is adjusted in a way that cover will slightly touch the back side of the table first.
3. Adjustment of guide arm: Both length of the guide arm and position on the guide arm axis have to be adjusted. Each of these should be adjusted separately. Fix the lower axis in a central position (centered in the holes) then adjust guide arm length until cover sit correctly on the right side. Move cover to the left side and check if cover sits correctly, if not move lower axis position and change length of the guide arm. Move the cover back to its original position to confirm, normally multiples tryout is required. Make sure there is no stress is transferred to the guide arm when machine is operating, stress induced arm will cause premature component fail.

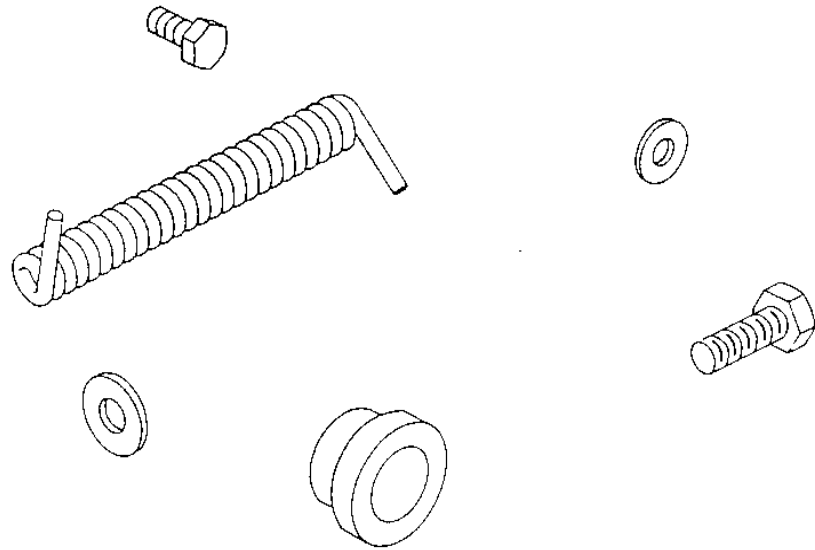

MECHANICAL DRAWING

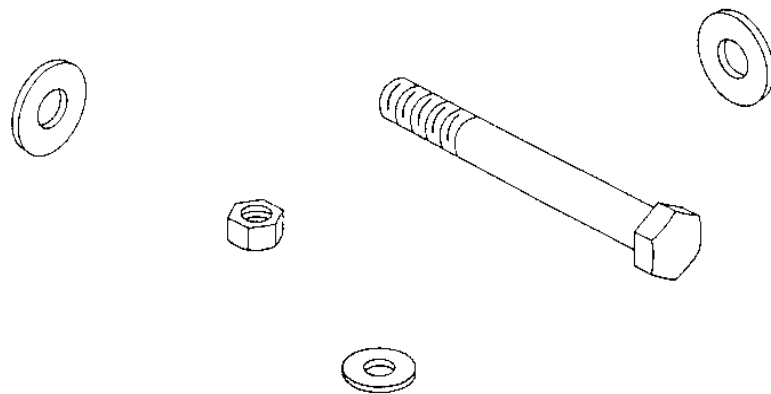

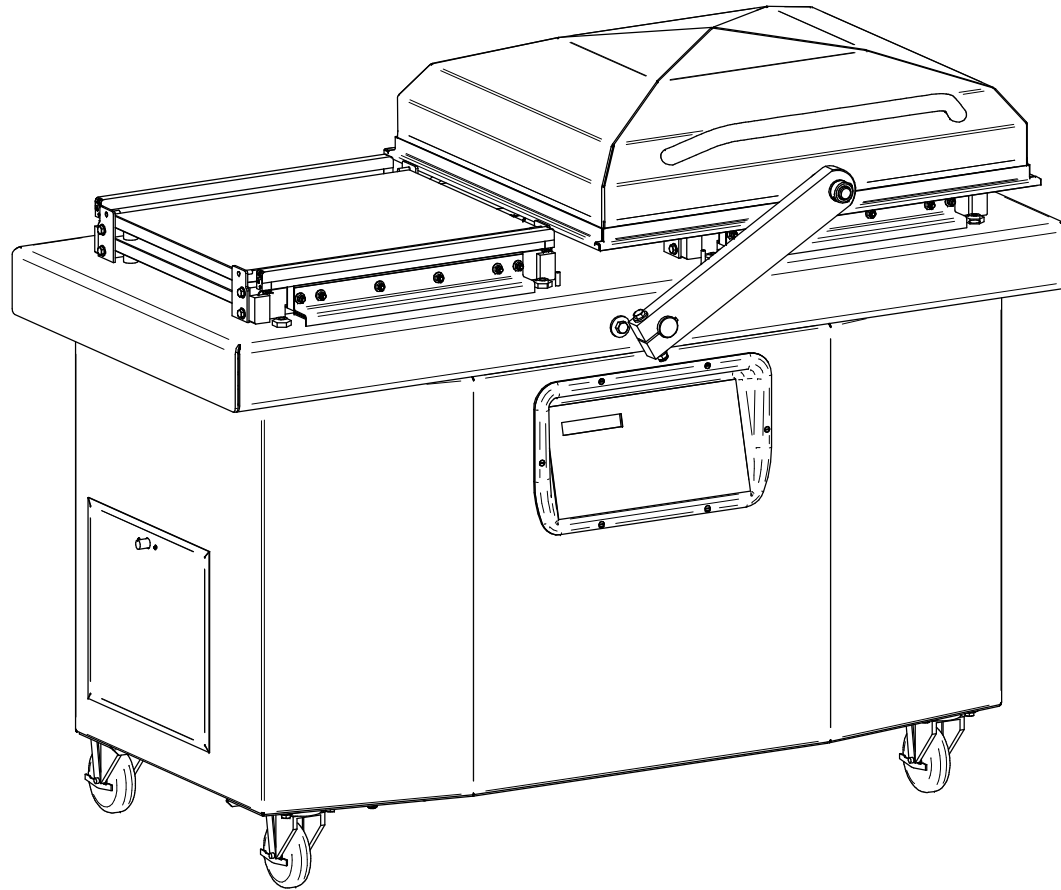

ITEM	PART #	DESCRIPTION	QT.
1	004A4109	VACUUM/ATMOSPHERE VALVE (OPT MUFFLER)	1
2	004A4110	VACUUM/ATMOSPHERE VALVE (OPT SOFT AIR)	1
3	004A4111	VACUUM/ATMOSPHERE VALVE (OPT SOFT AIR+MUFFLER)	1
4	004A4119	PUMP "BUSCH" 40M³ ASSY	1
5	004A4120	PUMP "BUSCH" 63M³ ASSY	1
6	004A4121	PUMP "BUSCH" 2X 20M³	1
7	004A4150	BASE MACHINE ASSEMBLY	1
8	004A4152	AIR REGULATOR VALVE ASSY	1
9	004B0126	UPPER SEAL BAR ASSY	2
10	004B4104	BELLOWS VALVE ASSY	1
11	004B4105	BELLOWS VALVE ASSY (OPT AIR REG)	1
12	004B4113	GAS VALVE ASSEMBLY (OPTION)	2
13	005A0455	COVER 8" ASSY	1
14	005A0533	LEFT GAS INJECTION BAR ASSEMBLY	2
15	005A0808	RIGHT GAS INJECTION BAR ASSEMBLY	2
16	005A1355	SEAL BAR ASSEMBLY W/SUPP. TWIN SEAL	4
17	005A1356	SEAL BAR ASSEMBLY W/SUPP. BAG CUT	4
18	005B0583	MC-40 CONTROL BOARD	1
19	005B1370	SLANTED FILLER PLATE ASS'Y	2
20	033-0014	MC-40 KEYBOARD "FOODPAK"	1
21	033-0015	MC-40 KEYBOARD "SIPROMAC"	1
22	033-0016	MC-40 KEYBOARD "HOLLYMATIC"	1
23	033-0018	MC-40 KEYBOARD "BERKEL"	1
24	033-0019	MC-40 KEYBOARD "BSA"	1
25	033-0021	MC-40 KEYBOARD "SUPPLY ONE"	1
26	039-0191	THERMOSTAT HAMMOND	1
27	039-0192	HEATER 100W HAMMOND	1
28	051-0255	BOLT 1/4-20 x 1-3/4" HEX SS	6
29	051-0300	BOLT 5/16"-18 x 3/4" S/S	16
30	051-0581	NUT 1/4"-20 NYLON LOCK S/S	6
31	051-0601	NUT 5/16"-18 NYLON LOCK S/S	16
32	051-0740	WASHER 1/4" FLAT S/S	12
33	051-0760	WASHER 5/16" FLAT S/S	32
34	104-0064	SILICONE TUBING 3/8" OD x 3/16" ID x 80mm	4
35	130-4PHB	4" PL.CASTER SWIVEL W/BRAKE	4

-OPTION -

MACHINE		420A		DEPT. TOL	METRIC	INCH	SIPROMAC ST-GERMAIN DE GRANTHAM QUEBEC CANADA
PART		MACHINE ASSEMBLY		USINAGE	± 0.1	± 0.004"	
				TOLERIE	± 0.5	± 0.020"	
				SOUDEGE	± 0.5	± 0.020"	
ITEM		CNC		N.T.S.		DEPT.	M
MAT.		DWG BY SBU		DATE 14-02-07		NO.	005B0598
LET.		MODIFICATION		DATE		INT.	1

LET.	MODIFICATION	DATE	INT.
------	--------------	------	------

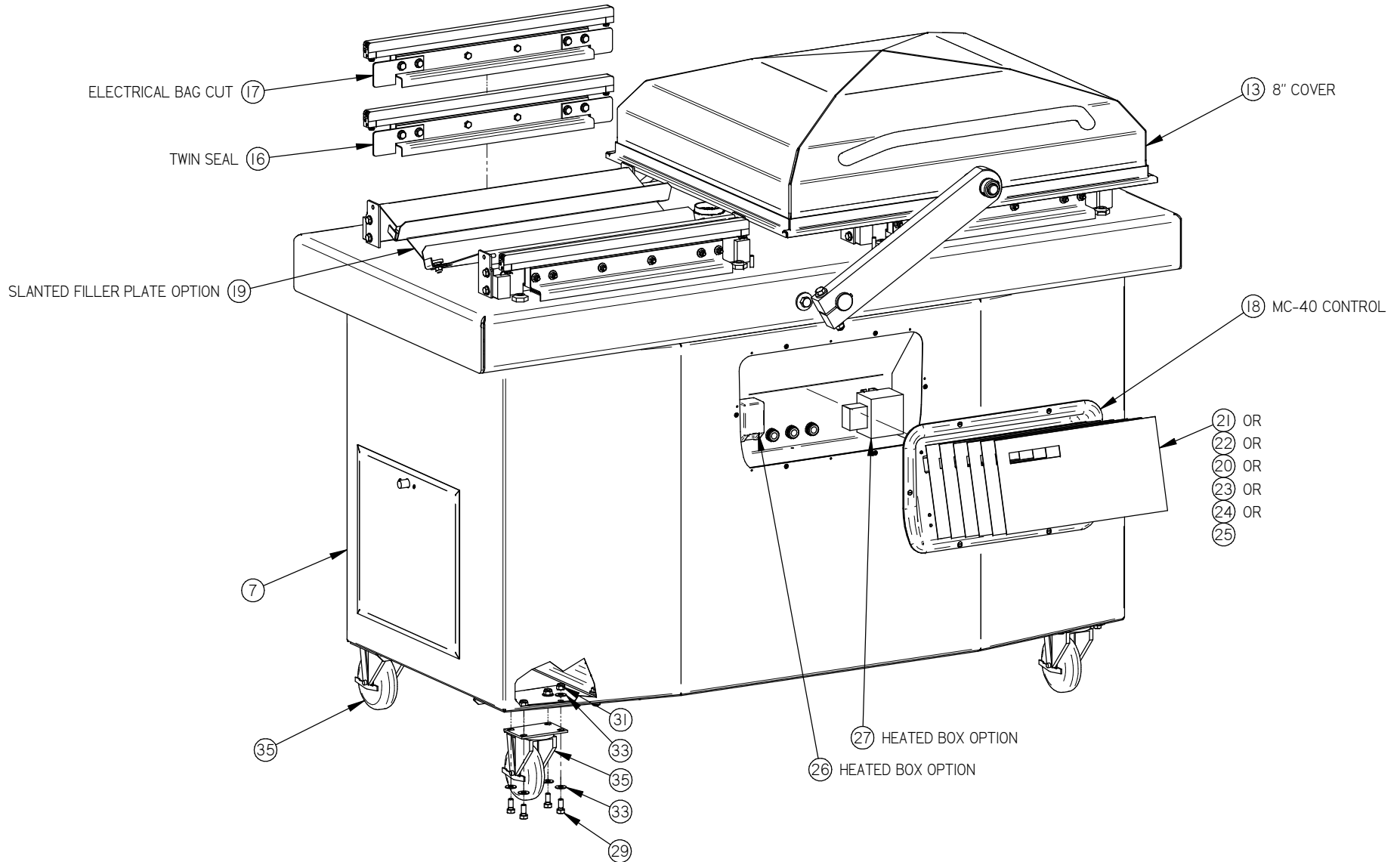

MACHINE		420A		DEPT. TOL.	METRIC	INCH	SIPROMAC ST-GERMAIN DE GRANTHAM QUEBEC CANADA
PART		MACHINE ASSEMBLY		USINAGE	± 0.1	± 0.004"	
				TOLERIE	± 0.5	± 0.020"	
				SOUDEAGE	± 0.5	± 0.020"	N.T.S.
ITEM	CNC	DEPT.	M	QTY.	1		
MAT.	DWG BY SBU	DATE 14-02-07	NO.	005B0598			
	APP. BY	DATE					

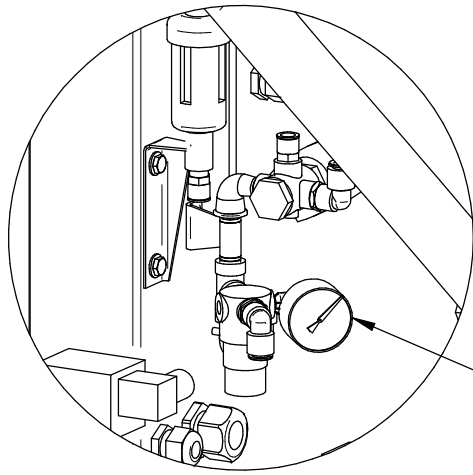

8 AIR REGULATOR OPTION

DETAIL A

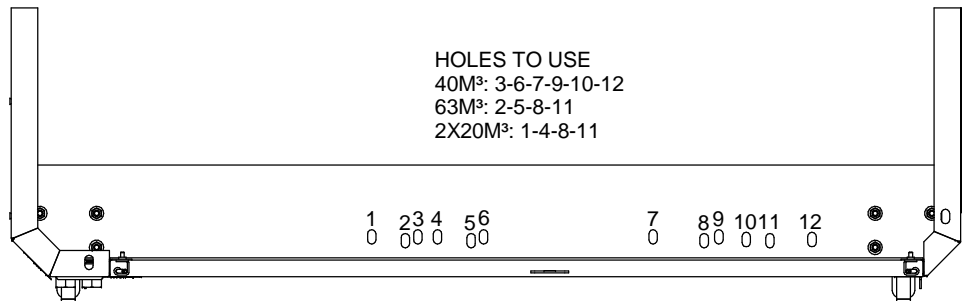
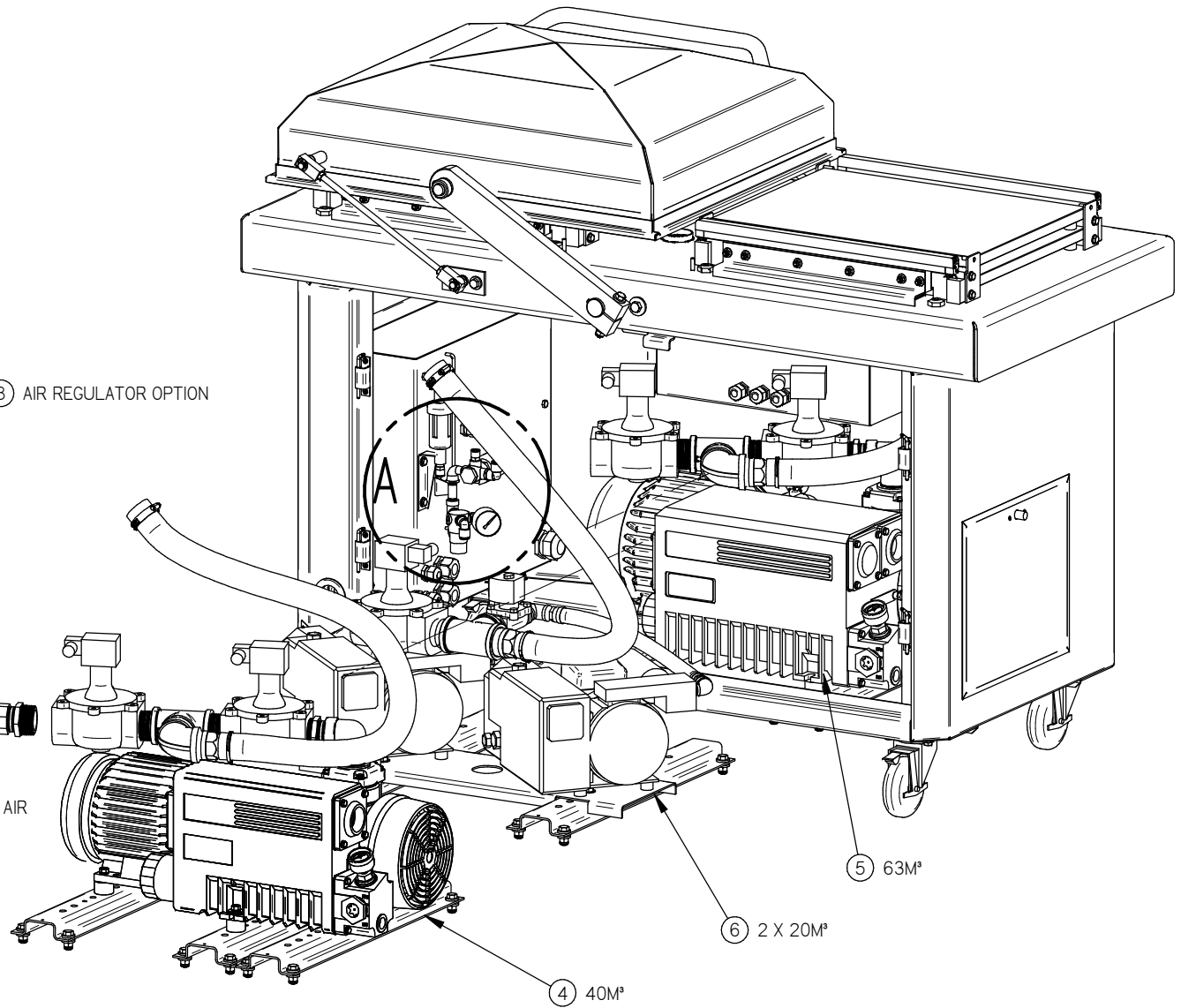
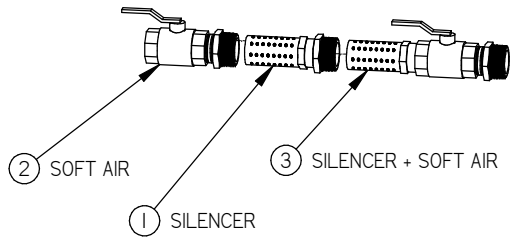

-PUMP + AIR REGULATOR INSTALLATION-

MACHINE 420A		DEPT. TOL. METRIC USINAGE ± 0.1 TOLERIE ± 0.5 SOUDAGE ± 0.5	INCH ± 0.004" ± 0.020" ± 0.020"	SIPROMAC ST-GERMAIN DE GRANTHAM QUEBEC CANADA
PART MACHINE ASSEMBLY		N.T.S.		
ITEM	CNC	DEPT.	M	QTY. 1
MAT.	DWG BY SBU	DATE 14-02-07	NO.	005B0598
	APP. BY	DATE		

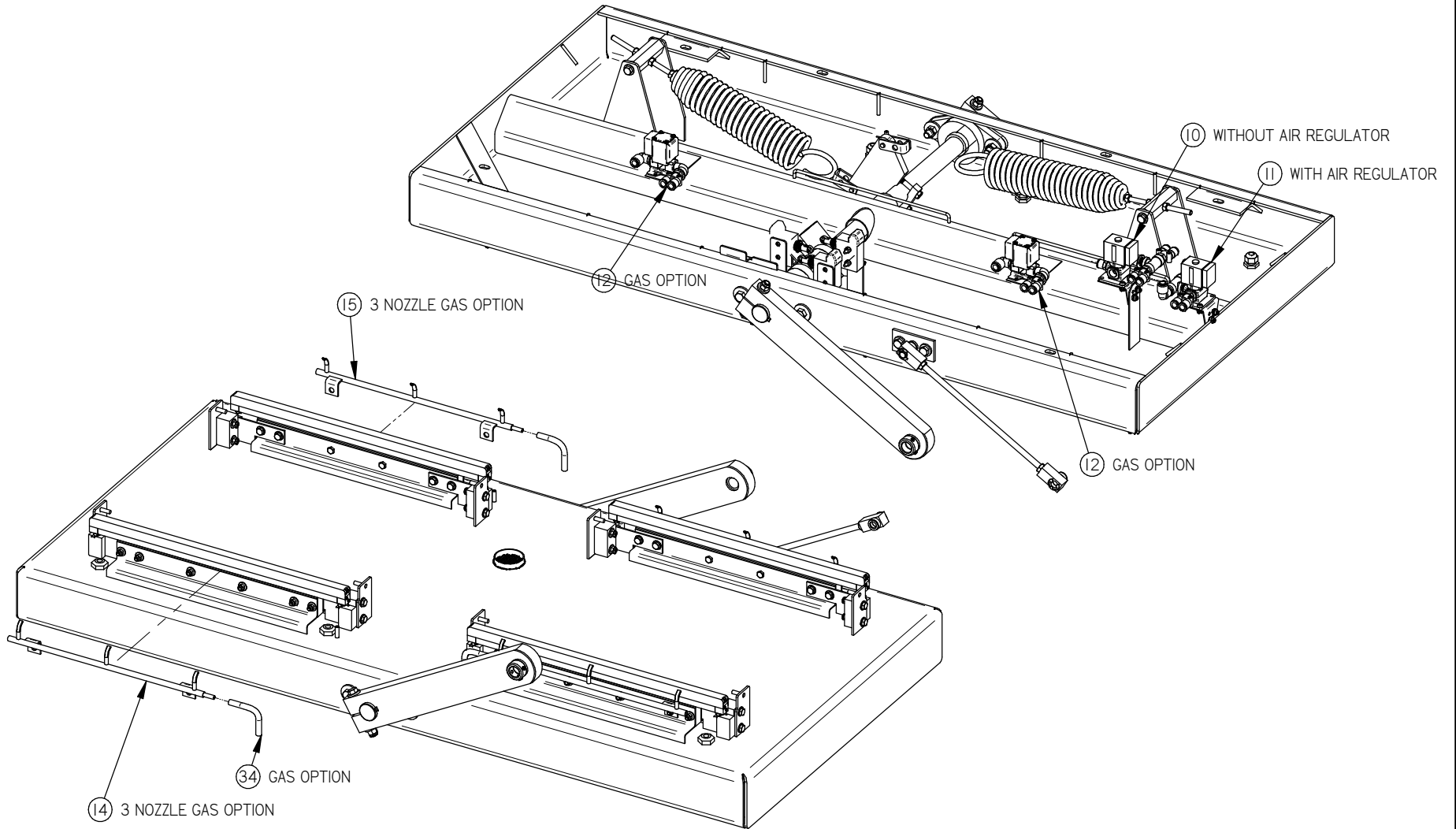

-GAS BAR + BELLOWS VALVE INSTALLATION-

MACHINE 420A		DEPT. TOL. METRIC	INCH	SIPROMAC ST-GERMAIN DE GRANTHAM QUEBEC CANADA
PART MACHINE ASSEMBLY		USINAGE ± 0.1	± 0.004"	
		TOLERIE ± 0.5	± 0.020"	
		SOUDEAGE ± 0.5	± 0.020"	
ITEM	CNC	N.T.S.		DEPT. M QTY. 1
MAT.	DWG BY SBU	DATE 14-02-07	NO. 005B0598	
	APP. BY	DATE		

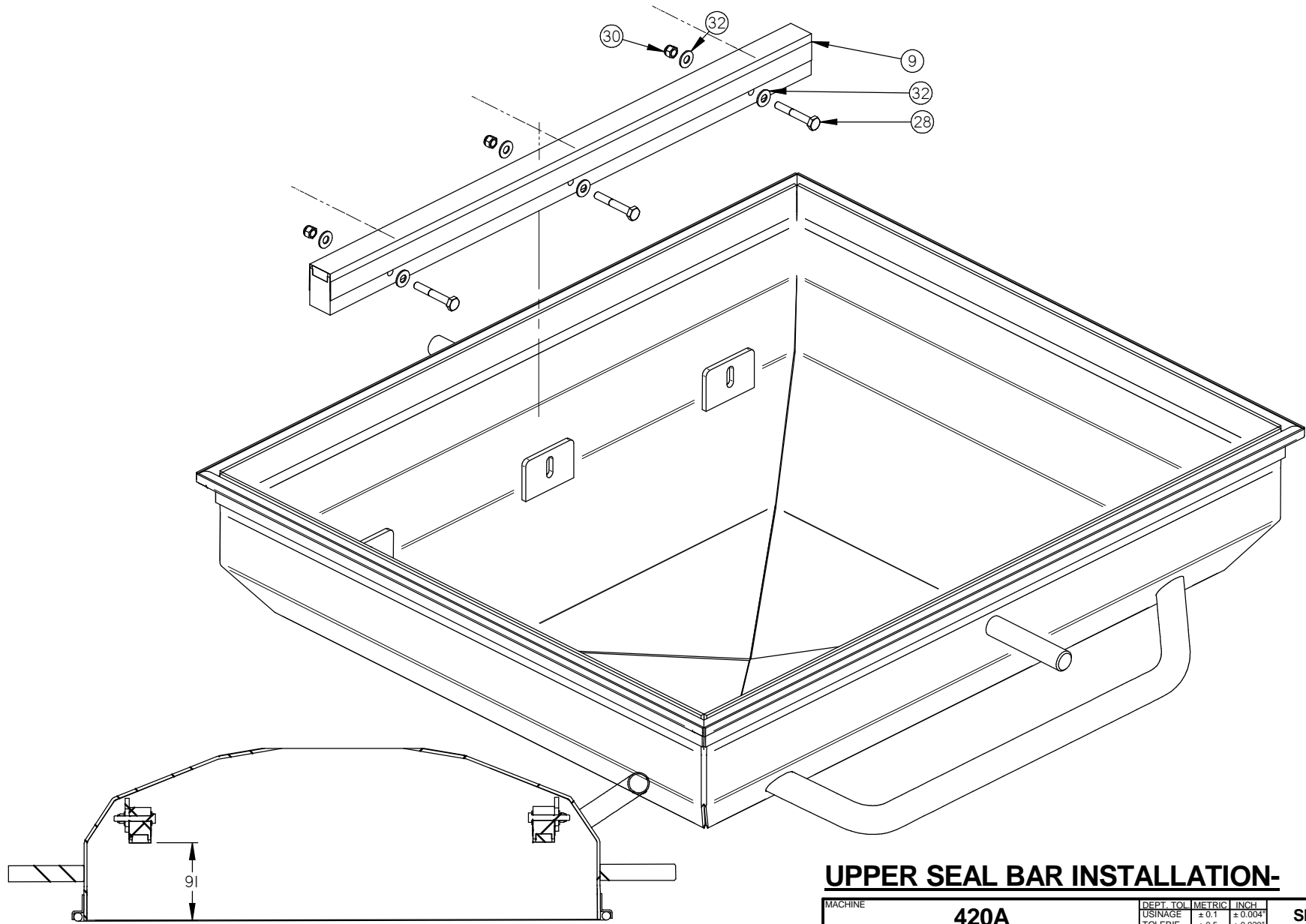

UPPER SEAL BAR INSTALLATION-

MACHINE		420A		DEPT. TOL.	METRIC	INCH	SIPROMAC ST-GERMAIN DE GRANTHAM QUEBEC CANADA
PART		MACHINE ASSEMBLY		USINAGE	± 0.1	± 0.004"	
ITEM		CNC		TOLERIE	± 0.5	± 0.020"	
MAT.		APP. BY		SOUDEGE	± 0.5	± 0.020"	N.T.S.
DWG BY		DATE		DEPT.		QTY.	1
APP. BY		DATE		M		005B0598	

005B0583

ITEM	PART #	DESCRIPTION	QT.
1	003A0403	CONTROL INSERT	1
2	051-0092	SCREW #4-40 x 1 1/4" FLAT SLT S/S	4
3	051-0713	WASHER #4 FLAT S/S	4
4	058-0120	CPVC SPACER 0.120" x 1/4" x 5/8"	4
5	051-0540	NUT #4-40 HEX S/S	8
6	051-0715	WASHER #4 LOCK SS	4
7	033-0038	MC-40 SENSOR VACUUM	1
8	051-01095	SCREW 8-32 x 1/2 FLAT SLOT SS	6
9	179-0004	NITRILE 1/2" X 1/8" AUTOCOLLANT X 1220mm long	1

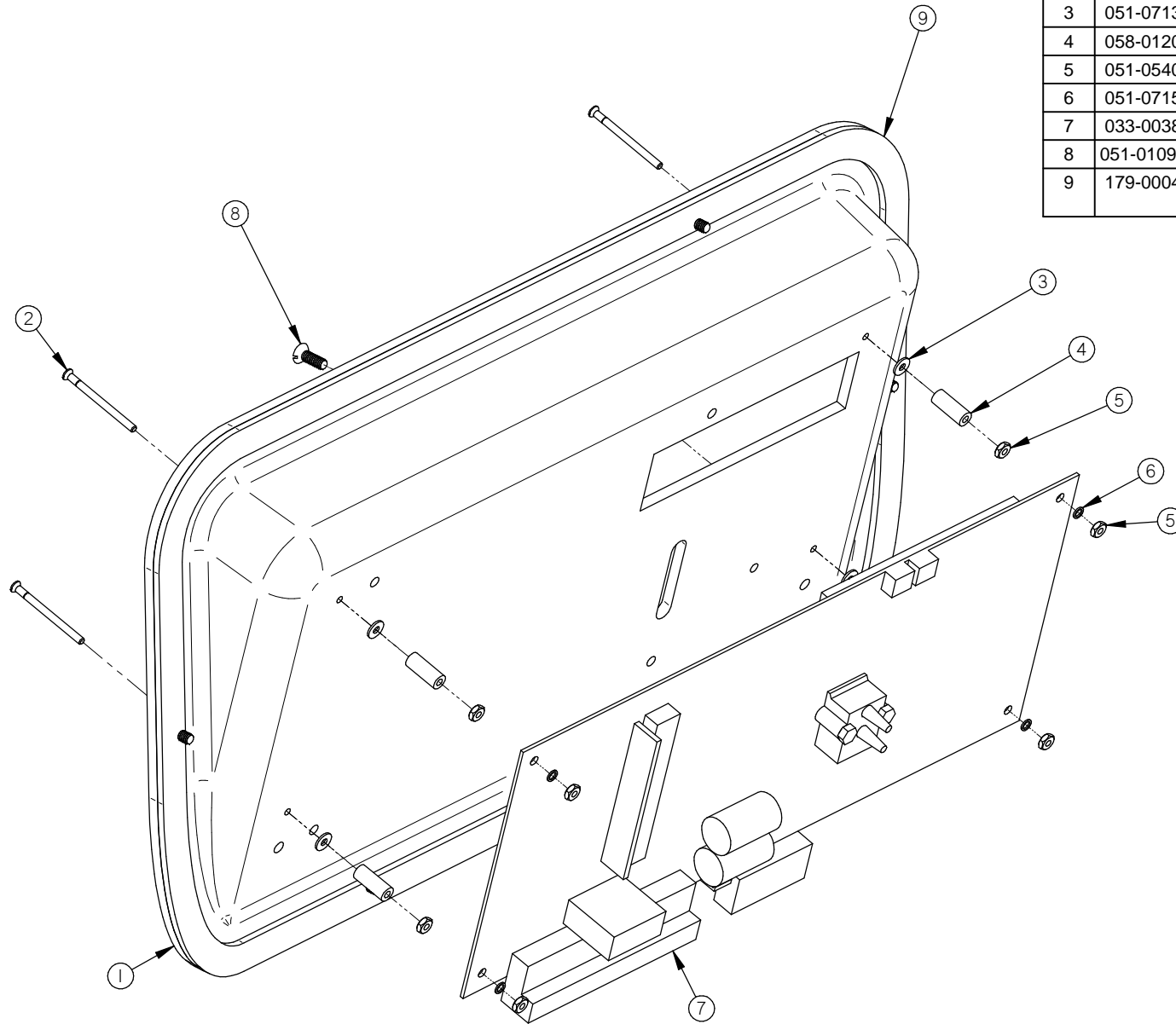

MACHINE		VACUUM		DEPT. TOL.	METRIC	INCH	SIPROMAC ST-GERMAIN DE GRANTHAM QUEBEC CANADA
PART		MC-40 CONTROL BOARD		USINAGE	± 0.1	± 0.004"	
				TOLERIE	± 0.5	± 0.020"	
ITEM		CNC		SOUDEGE	± 0.5	± 0.020"	N.T.S.
MAT.		DWG BY SBU		DATE 13-11-21		NO.	005B0583
		APP. BY		DATE		DEPT. M	
LET.		MODIFICATION		DATE		INT.	QTY. 1

LET. MODIFICATION DATE INT.

004B4104

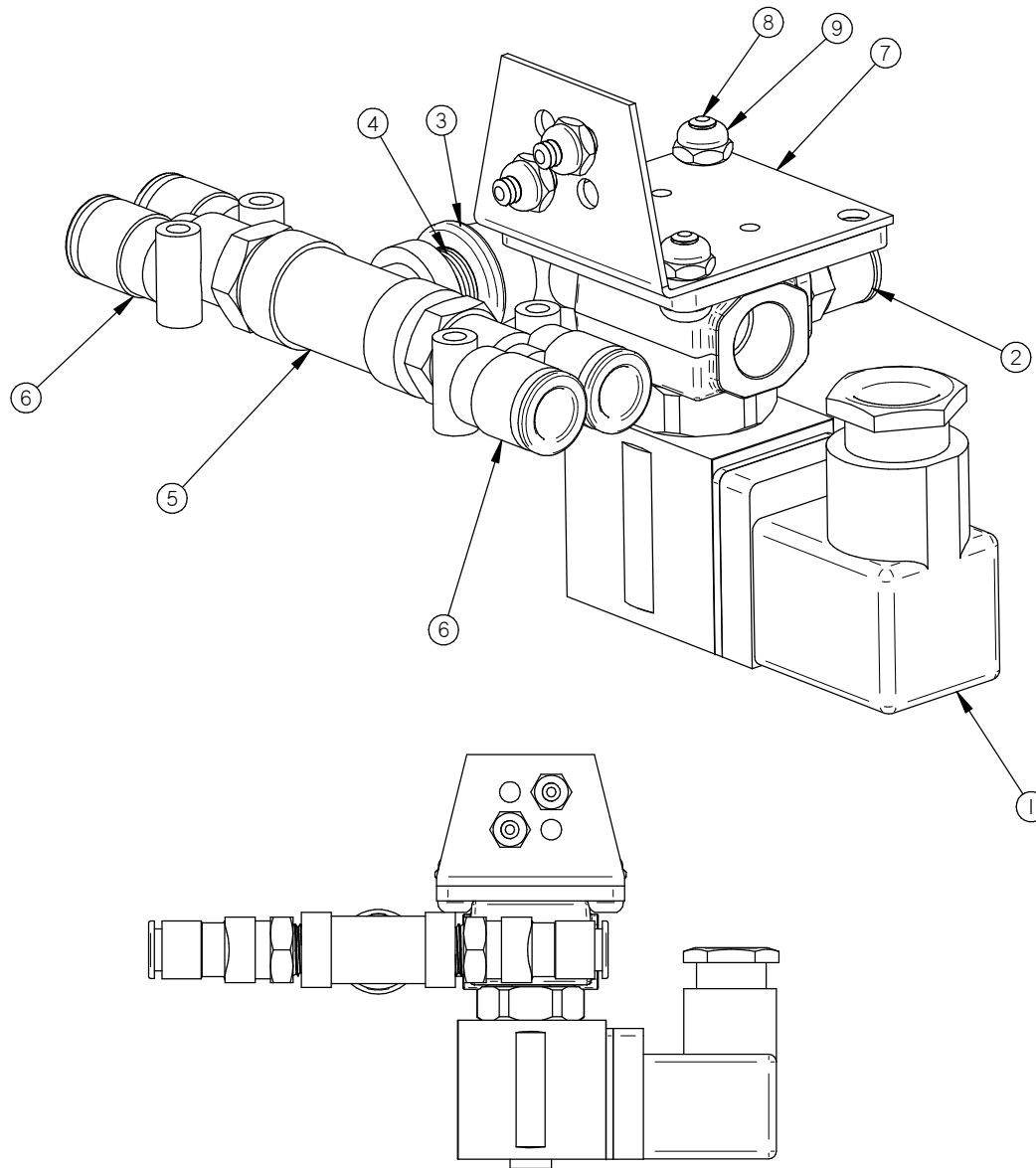

ITEM	PART #	DESCRIPTION	QT.
1	106-00701	VALVE 3WAY 24V 1/4"NPT	1
2	102-0410	MALE CONN.1/4"MNPTx3/8" T. QUICK	1
3	100-0065	STREET ELBOW 1/4" NPT SS	1
4	100-0225	CLOSE NIPPLE 1/4" NPT SS	1
5	100-0463	TEE 1/4" NPT S/S	1
6	102-0361	Y BRANCH 1/4" MNPT X 3/8" T. QUICK	2
7	001B6779	VALVE SUPPORT BRACKET	1
8	051-0144	SCREW #10-24 N.C 1/2"PAN PHIL. S/S	4
9	051-0572	NUT #10-24 NYLON LOCK S/S	4

MACHINE		VACUUM		DEPT. TOL.	METRIC	INCH	SIPROMAC ST-GERMAIN DE GRANTHAM QUEBEC CANADA
PART		BELLOWS VALVE ASSY		USINAGE	± 0.1	± 0.004"	
				TOLERIE	± 0.5	± 0.020"	
ITEM		CNC		SOUDEAGE	± 0.5	± 0.020"	N.T.S.
MAT.		DWG BY SBU		DATE	14-05-27		
APP. BY		DATE		DEPT.	M		QTY. 1
							004B4104

A	VALVE UPDATE	14-05-27	SBU
LET.	MODIFICATION	DATE	INT.

005A0455

ITEM	PART #	DESCRIPTION	QT.
1	004A0238	COVER 8" WELDED ASSY	1
2	179-0020	NEOPRENE SPONGE 1/2" x 9'	1

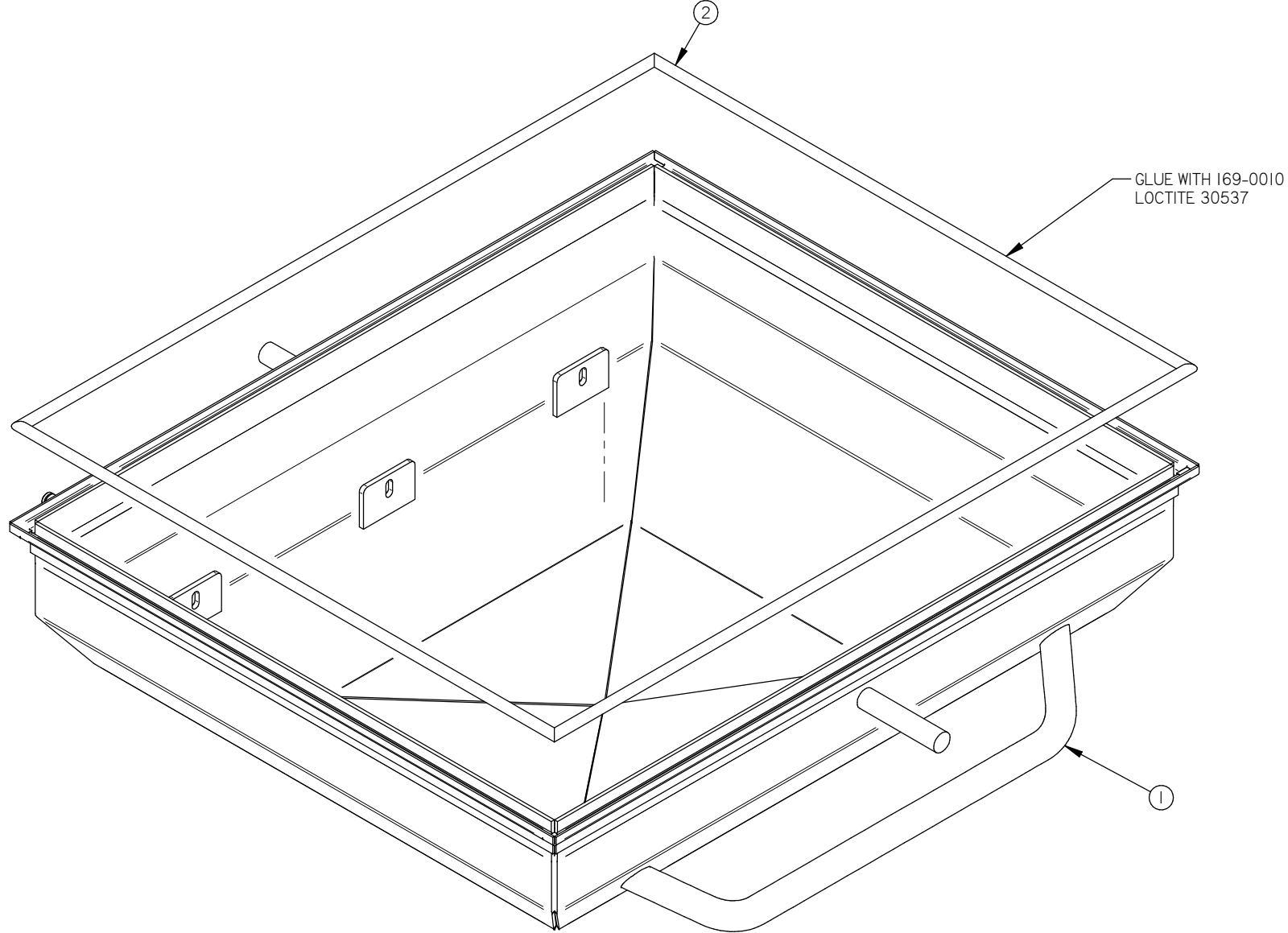

B	COVER WIDENED BY 54MM FOR 19" BAR	14-01-29	SBU
LET.	MODIFICATION	DATE	INT.

MACHINE	420A			DEPT. TOL.	METRIC	INCH	SIPROMAC ST-GERMAIN DE GRANTHAM QUEBEC CANADA
PART	COVER 8" ASSY			USINAGE	± 0.1	± 0.004"	
				TOLERIE	± 0.5	± 0.020"	
ITEM		CNC		SOUDEAGE	± 0.5	± 0.020"	N.T.S.
MAT.		DWG BY	SBU	DATE	14-01-28	NO.	005A0455
		APP. BY		DATE		DEPT.	
						QTY.	1

004A4150

ITEM	PART #	DESCRIPTION	QT.
1	004A4116	LEFT REAR ACCESS DOOR PRE-ASSY	1
2	004A4118	RIGHT REAR ACCESS DOOR ASSY	1
3	004A4151	TABLE ASSY W/ARM	1
4	005A0333	FILLER PLATE	4
5	005D0599	STRUCTURE ASSY	1
6	051-0360	BOLT 3/8"-16nc. X 1" S/S	6
7	051-0622	NUT 3/8"-16nc. NYLON LOCK S/S	6
8	051-0783	WASHER 3/8" FLAT THICK S/S	12

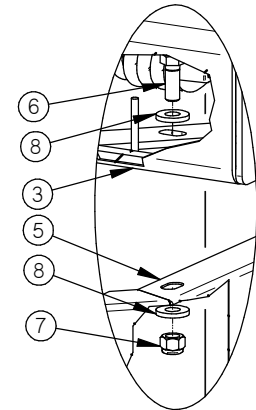
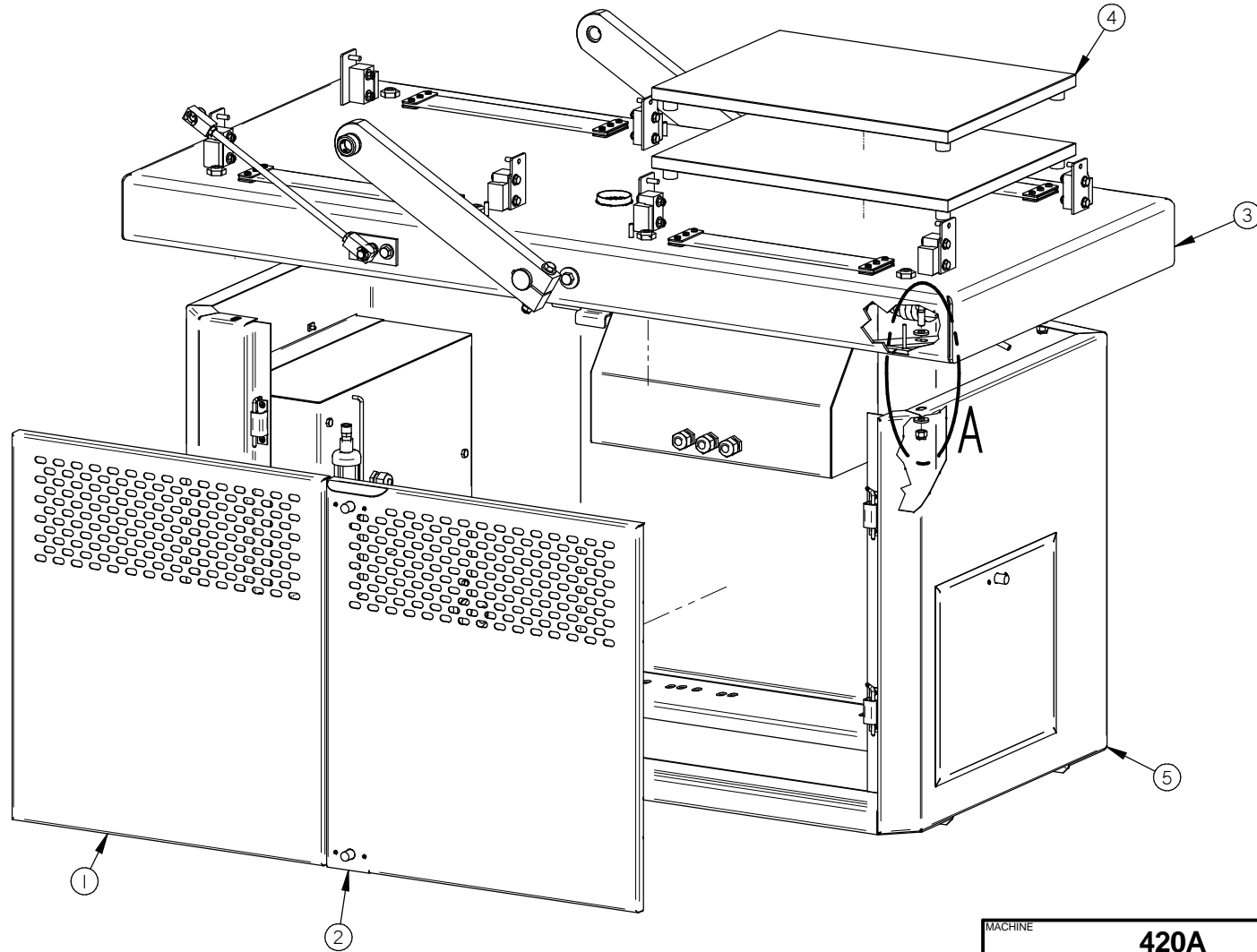

DETAIL A

LET.	MODIFICATION	DATE	INT.
------	--------------	------	------

MACHINE		420A		DEPT. TOL.	METRIC	INCH	SIPROMAC ST-GERMAIN DE GRANTHAM QUEBEC CANADA
PART		BASE MACHINE ASSEMBLY		USINAGE	± 0.1	± 0.004"	
				TOLERIE	± 0.5	± 0.020"	
				SOUDEAGE	± 0.5	± 0.020"	N.T.S.
ITEM	CNC	DEPT.	M	QTY.	1		
MAT.	DWG BY SBU	DATE 14-02-07	NO.	004A4150			
		APP. BY	DATE				

004A4118

ITEM	PART #	DESCRIPTION	QT.
1	004A4117	RIGHT REAR ACCESS DOOR PRE-ASSY	1
2	056-2600	SPRING PAWL LATCHE SS KNOB	2
3	051-0071	SCREW 4-40 x 1/4" RND SLOT S/S	4
4	051-0541	NUT # 4-40 NYLON LOCK SS	4

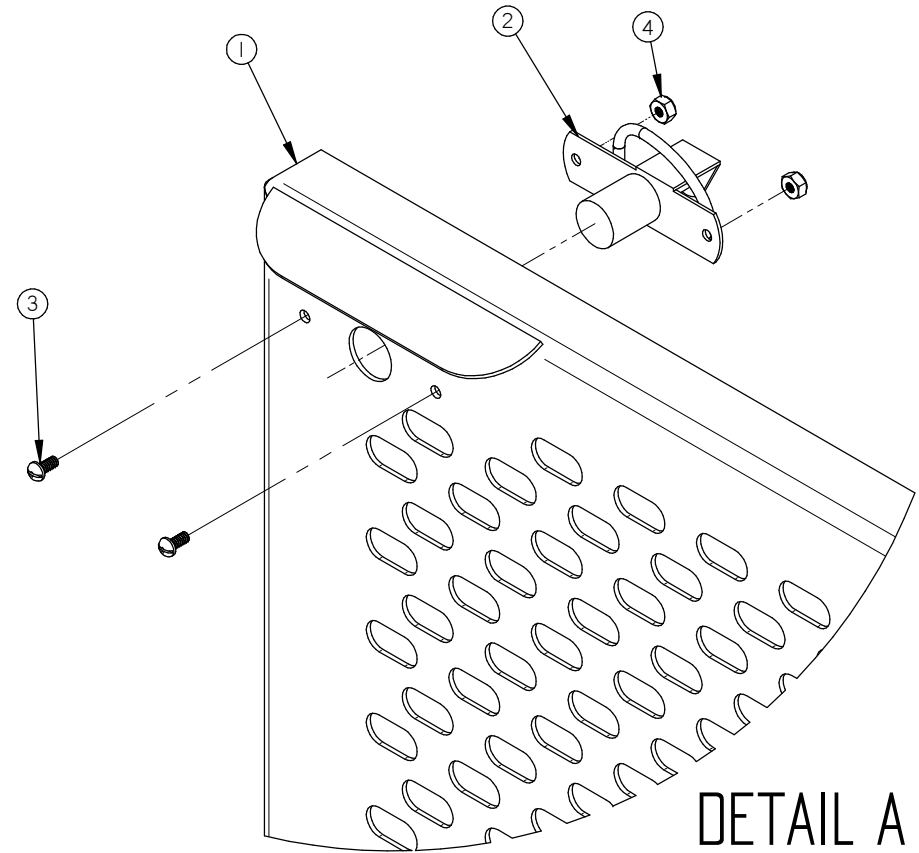
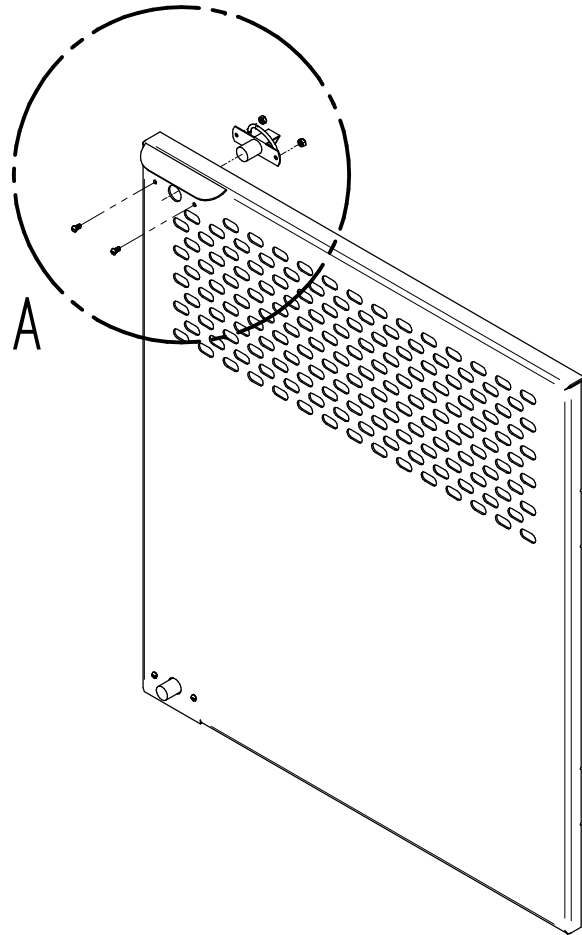

DETAIL A

LET.	MODIFICATION	DATE	INT.
------	--------------	------	------

MACHINE		420A		DEPT. TOL.	METRIC	INCH	SIPROMAC ST-GERMAIN DE GRANTHAM QUEBEC CANADA
PART		RIGHT REAR ACCESS DOOR ASSY		USINAGE	± 0.1	± 0.004"	
ITEM		CNC		TOLERIE	± 0.5	± 0.020"	
MAT.		APP. BY		SBU		DATE	14-02-06
						NO.	004A4118
						DEPT.	M
						QTY.	1

005D0599

ITEM	PART #	DESCRIPTION	QT.	ITEM	PART #	DESCRIPTION	QT.
11	056-3010-1	HINGE CONCEALED SS304 - BASE	4	1	004A4090	ACCESS DOOR ASSEMBLY	1
12	056-3010-3	HINGE CONCEALED SS304 - PIN	4	2	004A4098	ELECTRIC BOX ASS'Y	1
13	102-0551	BULKHEAD 1/4"NPT X 3/8 TUBE QUICK	2	3	004A4138	VACUUM SENSOR FILTER	1
14	127-0040	STICKER "AIR" BLUE/WHITE 1" X 2"	1	4	004D0437	STRUCTURE WELD ASSY	1
15	127-0041	STICKER "GAS" YELLOW/BLACK 1" X 2"	1	5	036-0265	GROMMET 1-1/2" ID X 2-3/8" OD RUBBER	1
				6	036-0409	PRESSE-ETOUPE CD13	3
				7	051-01385	SCREW 10-24 x 1/2"FLAT-UND. PHIL S/S	8
				8	051-0144	SCREW #10-24 N.C 1/2"PAN PHIL. S/S	8
				9	051-0180	BOLT. HEX. 1/4"-20 NC. x 1/2" S/S	2
				10	051-0740	WASHER 1/4" FLAT S/S	2

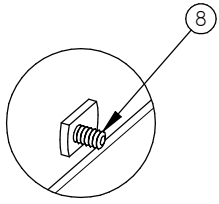

DETAIL B

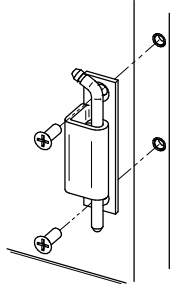

DETAIL A

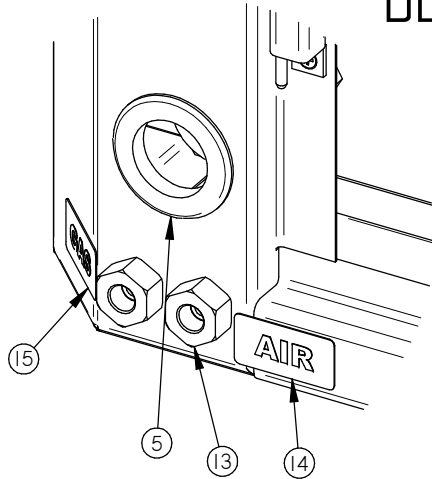

DETAIL C

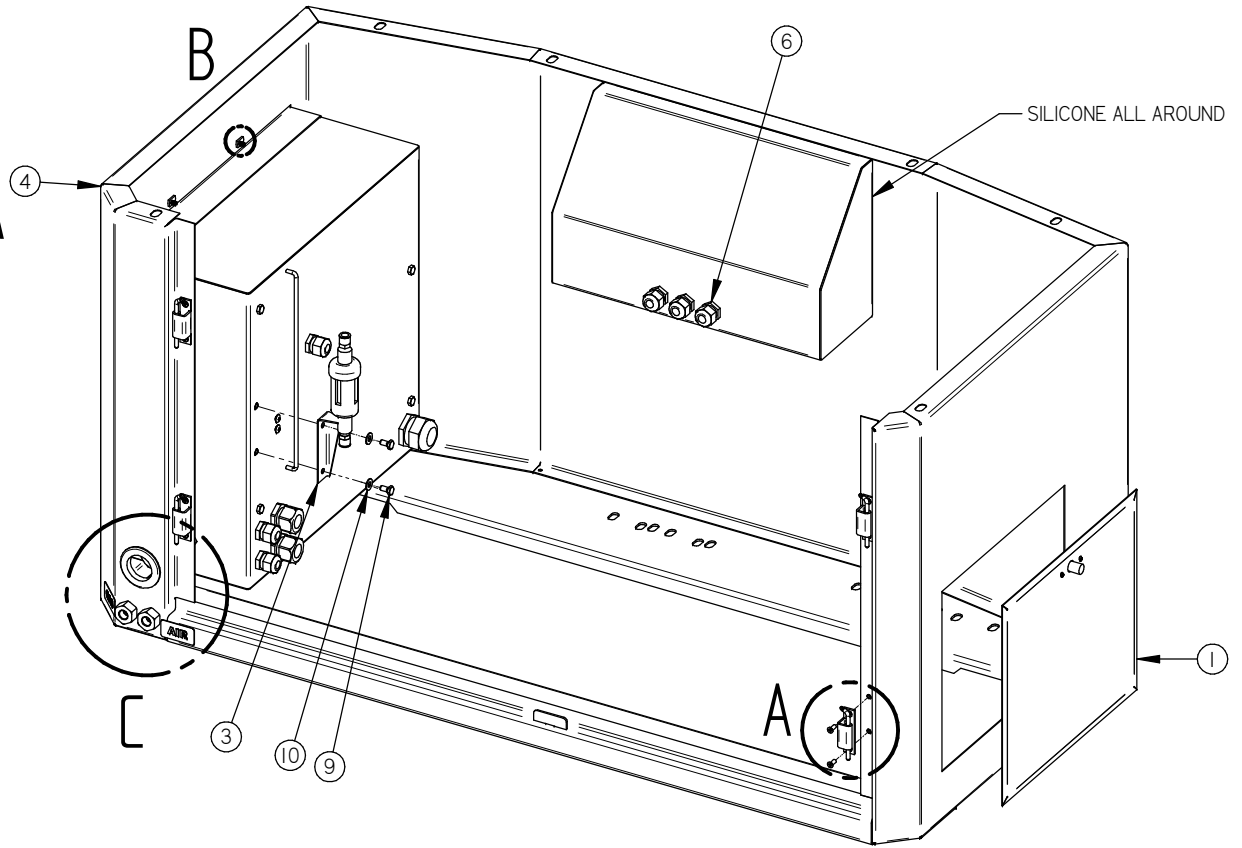

A	NEW DESIGN	14-02-06	SBU
LET.	MODIFICATION	DATE	INT.

MACHINE	420A			DEPT. TOL.	METRIC	INCH	SIPROMAC ST-GERMAIN DE GRANTHAM QUEBEC CANADA
PART	STRUCTURE ASSY			USINAGE	± 0.1	± 0.004"	
				TOLERIE	± 0.5	± 0.020"	
				SOUDEAGE	± 0.5	± 0.020"	
ITEM	CNC	DEPT.	M	QTY.	1	N.T.S.	
MAT.	DWG BY	DATE	14-02-06	NO.	005D0599		
	APP. BY	DATE					

004A4098

ITEM	PART #	DESCRIPTION	QT.	ITEM	PART #	DESCRIPTION	QT.
11	051-0580	NUT 1/4"-20 S/S	4	1	004A4099	E-BOX PRE-ASSY	1
12	051-0210	BOLT 1/4"-20nc. X 1" S/S	4	2	056-3010-1	HINGE CONCEALED SS304 - BASE	2
13	051-0581	NUT 1/4"-20 NYLON LOCK S/S	4	3	056-3010-3	HINGE CONCEALED SS304 - PIN	2
14	051-0139	SCREW 10-24 x 1/2" FLAT PHIL S/S	4	4	004A4102	E-BOX FALSE BOTTOM	1
15	028-0105	GROUND BARRIER (6 HOLES)	1	5	036-0430	PRESSE-ÉTOUPE CD29	1
16	051-0128	SCREW 10-24 x 3/8" TRUSS PHIL S/S	4	6	036-0409	PRESSE-ÉTOUPE CD13	3
				7	004A4100	E-BOX DOOR ASSEMBLY	1
				8	036-0420	PRESSE-ÉTOUPE CD21	2
				9	036-0440	PRESSE-ÉTOUPE CD36	1
				10	051-0600	NUT 5/16" -18 S/S	4

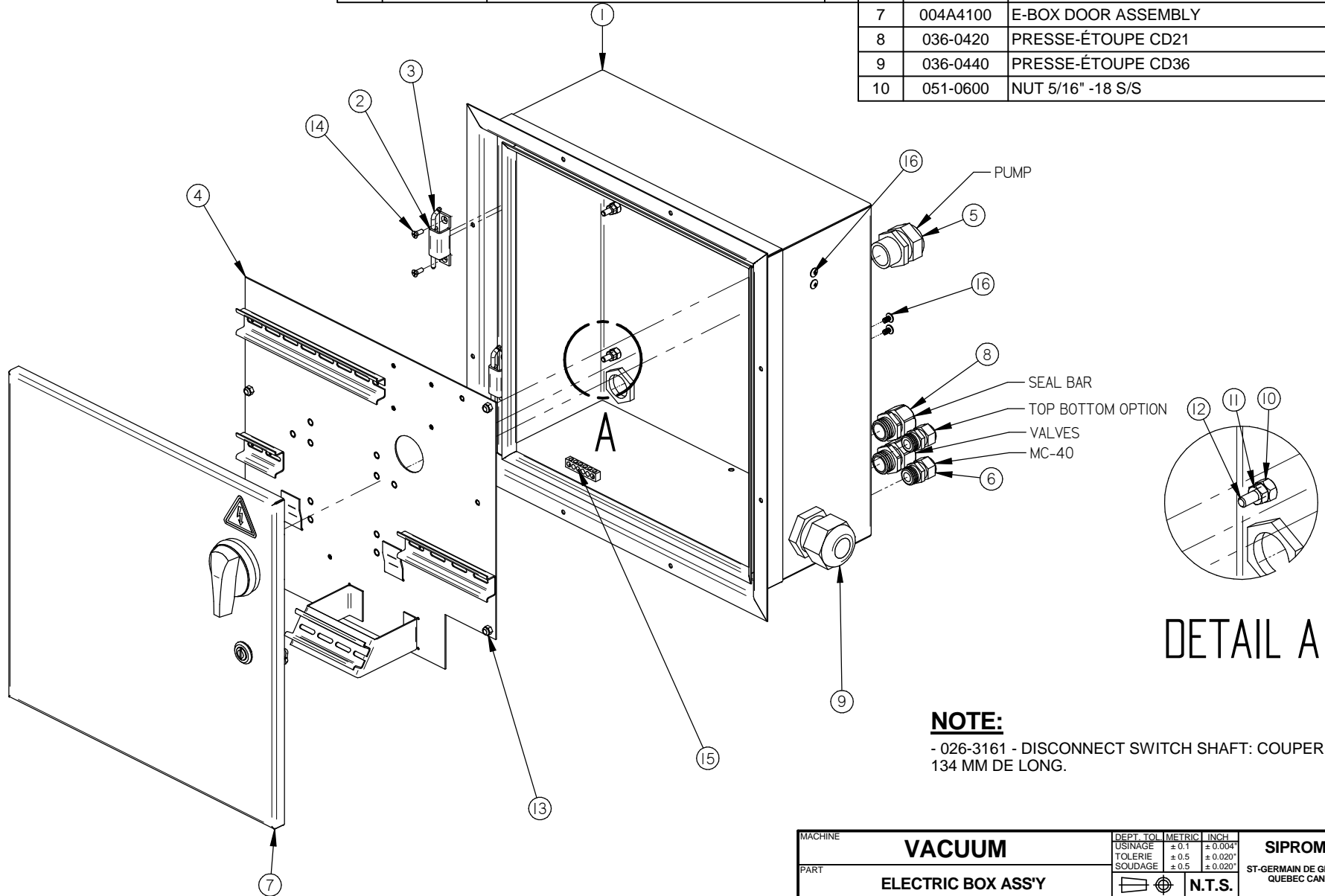

NOTE:

- 026-3161 - DISCONNECT SWITCH SHAFT: COUPER À 134 MM DE LONG.

LET.	MODIFICATION	DATE	INT.
------	--------------	------	------

MACHINE		VACUUM		DEPT. TOL. METRIC	INCH	SIPROMAC	
PART		ELECTRIC BOX ASS'Y		USINAGE	± 0.1	± 0.004"	ST-GERMAIN DE GRANTHAM QUEBEC CANADA
ITEM		CNC		TOLERIE	± 0.5	± 0.020"	
MAT.		APP. BY SBU		SOUDAGE	± 0.5	± 0.020"	
		DATE 13-09-23		N.T.S.		DEPT.	M
		DATE				QTY.	1
						004A4098	

004A4100

ITEM	PART #	DESCRIPTION	QT.
1	004A4101	E-BOX DOOR PRE-ASSY	1
2	056-2612	CAM LOCK QUARTER TURN SS304	1
3	179-0026	D-SHAPED RUBBER SEAL 1683mm LONG	1
4	026-3160	HANDLE RED/YELLOW NEMA 4X, COMPACT, PADLOCKABLE	1
5	127-0100	STICKER ELEC.HAZARD ISO 2-1/2" TRIANGLE	1

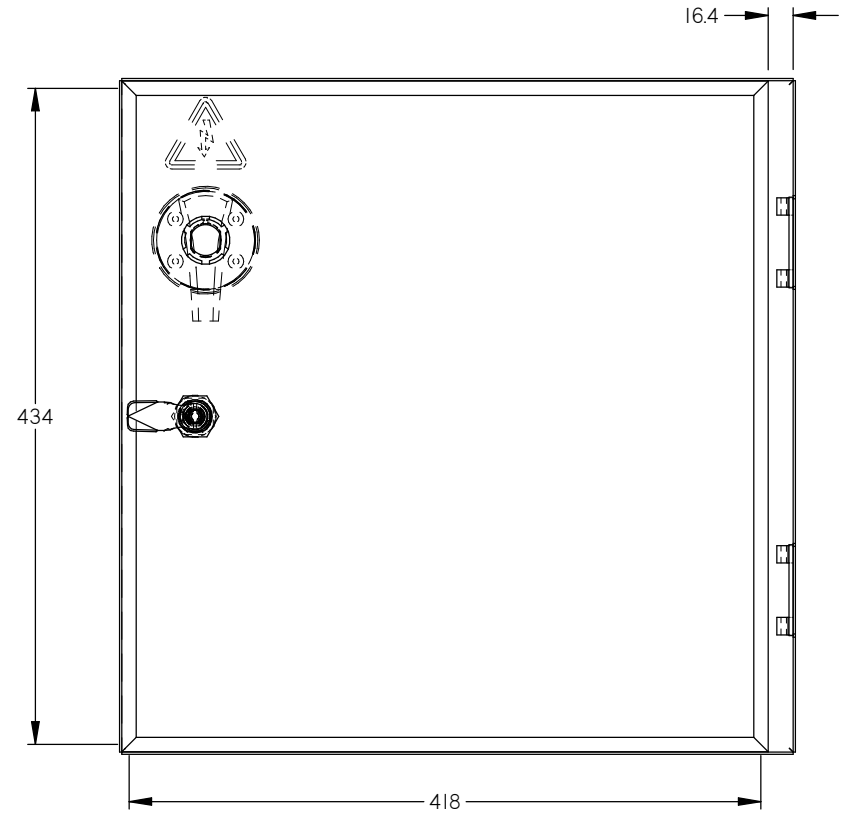
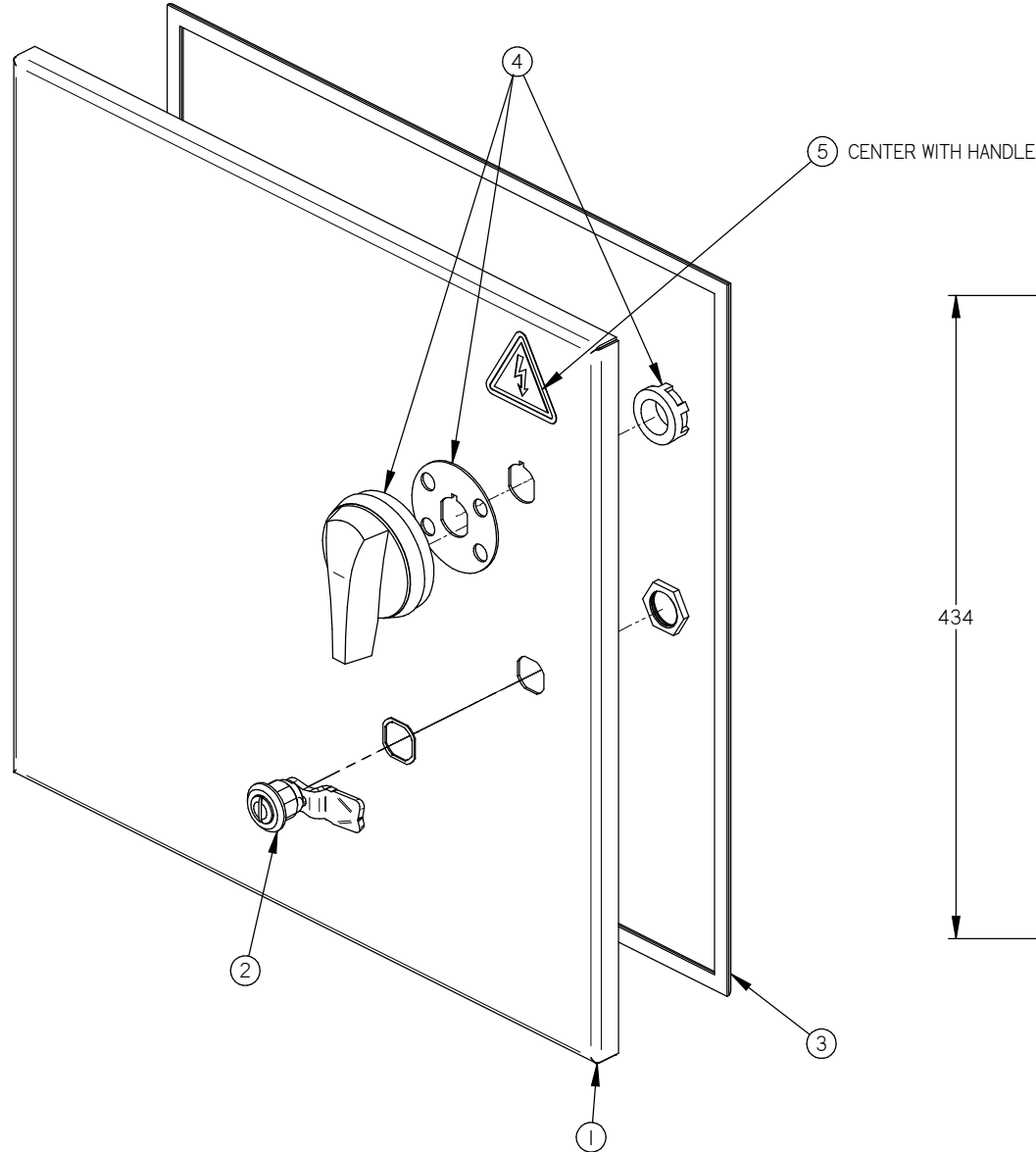

LET.	MODIFICATION	DATE	INT.
------	--------------	------	------

MACHINE		VACUUM		DEPT. TOL.	METRIC	INCH	SIPROMAC ST-GERMAIN DE GRANTHAM QUEBEC CANADA
PART		E-BOX DOOR ASSEMBLY		USINAGE	± 0.1	± 0.004"	
ITEM		CNC		TOLERIE	± 0.5	± 0.020"	
MAT.		APP. BY SBU		DATE	13-09-17	NO.	004A4100
						DEPT.	M
						QTY.	1

004A4090

ITEM	PART #	DESCRIPTION	QT.
1	004A4089	ACCESS PANEL PRE-ASSY	1
2	056-2600	SPRING PAWL LATCHE SS KNOB	1
3	051-0071	SCREW 4-40 x 1/4" RND SLOT S/S	2
4	051-0541	NUT # 4-40 NYLON LOCK SS	2

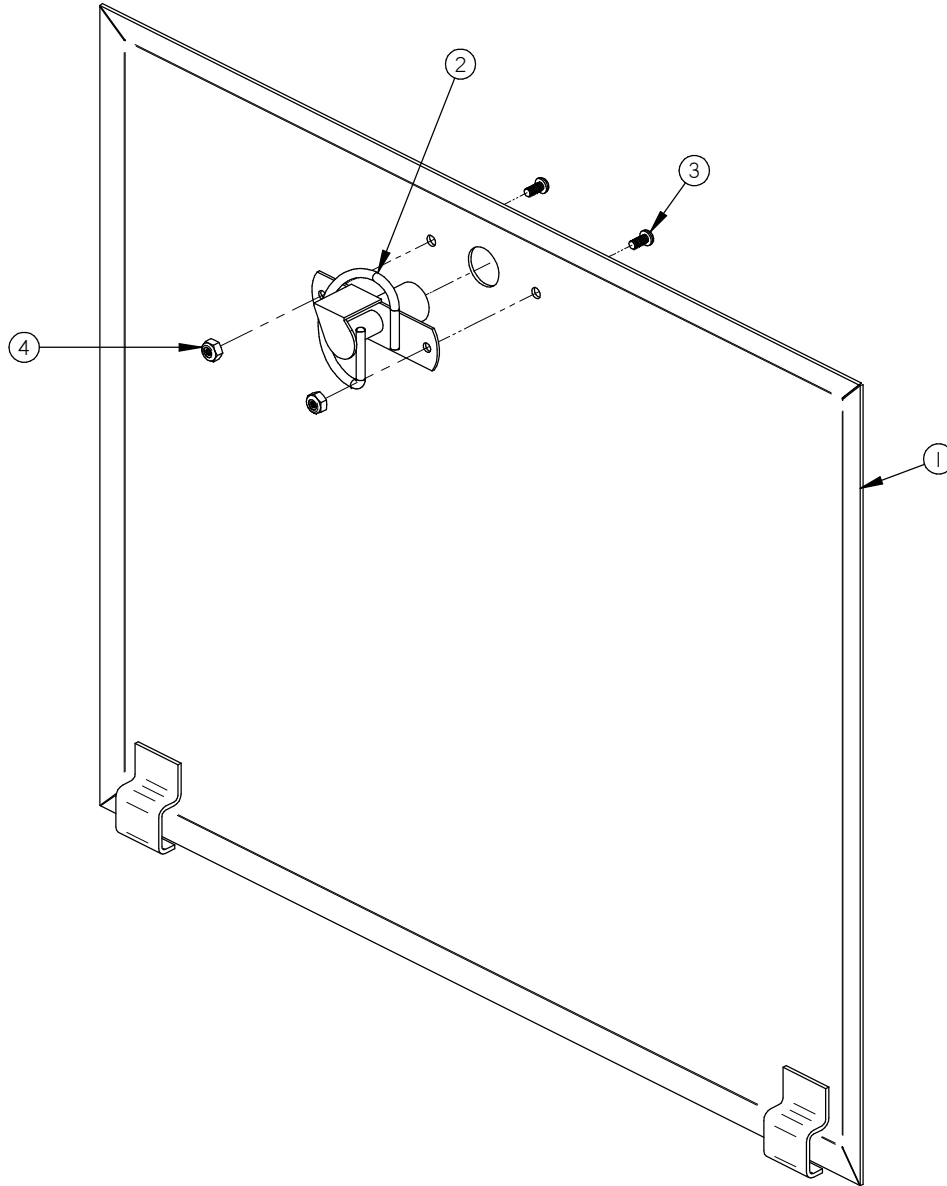

LET.	MODIFICATION	DATE	INT.
------	--------------	------	------

MACHINE		VACUUM		DEPT. TOL.	METRIC	INCH	SIPROMAC ST-GERMAIN DE GRANTHAM QUEBEC CANADA
PART		ACCESS DOOR ASSEMBLY		USINAGE	± 0.1	± 0.004"	
				TOLERIE	± 0.5	± 0.020"	
				SOUDEAGE	± 0.5	± 0.020"	N.T.S.
ITEM		CNC		DEPT.	M		QTY. 1
MAT.		DWG BY SBU	DATE 13-09-11	NO.	004A4090		
		APP. BY	DATE				

004A4138

ITEM	PART #	DESCRIPTION	QT.
1	004A4139	VACUUM SENSOR FILTER SUPPORT	1
2	114-2020	FILTER / DRYER 1/4"mnpt. X 1/4"t.p. COMP.	1
3	102-0410	MALE CONN.1/4"MNPTx3/8"t.QUICK	2

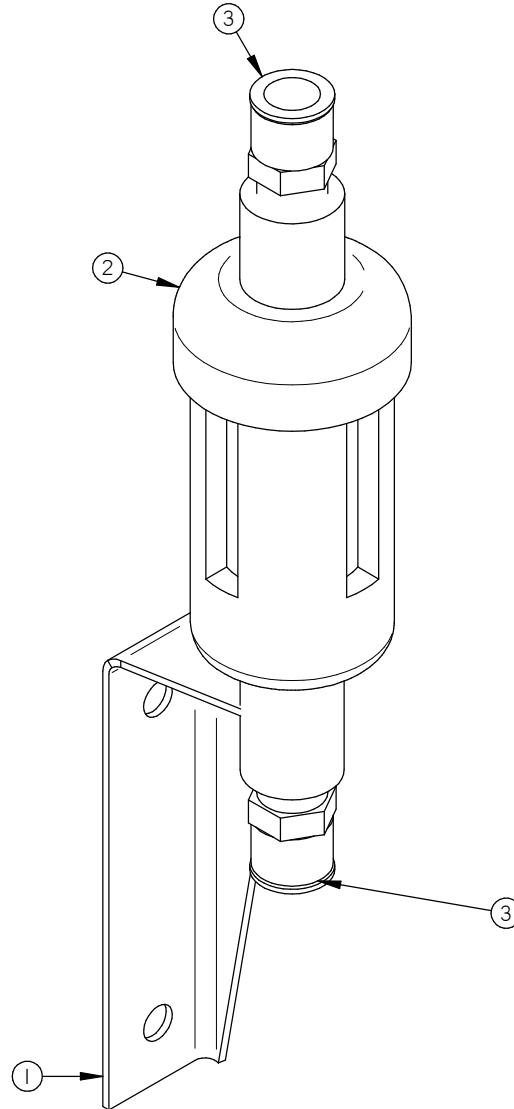

MACHINE		VACUUM		DEPT. TOL.	METRIC	INCH	SIPROMAC ST-GERMAIN DE GRANTHAM QUEBEC CANADA
PART		VACUUM SENSOR FILTER		USINAGE ± 0.1	± 0.004"	N.T.S.	
ITEM		CNC		TOLERIE ± 0.5	± 0.020"		
MAT.		APP. BY SBU		SOUDAGE ± 0.5	± 0.020"		
LET.		MODIFICATION		DATE		INT.	DEPT. M QTY. 1
				DATE 13-11-19		NO. 004A4138	

LET.	MODIFICATION	DATE	INT.
------	--------------	------	------

004A4151

ITEM	PART #	DESCRIPTION	QT.	ITEM	PART #	DESCRIPTION	QT.
11	051-0581	NUT 1/4"-20 NYLON LOCK S/S	16	1	002-0326	LEFT SEAL BAR GUIDE BLOCK	4
12	051-0622	NUT 3/8"-16nc. NYLON LOCK S/S	2	2	002-0327	RIGHT SEAL BAR GUIDE BLOCK	4
13	051-0740	WASHER 1/4" FLAT S/S	32	3	002-0390	COVER ARM COLLAR	2
14	051-0783	WASHER 3/8" FLAT THICK S/S	4	4	004A0348	COVER ARM ASSY	2
15	056-01675	KEY 1/4" SQ. x 1 1/4" ROUNDED END S/S	2	5	004B0124	TABLE ASSEMBLY	1
16	056-0331	EXT. RETAINING RING 1/2" S/S	2	6	004B1393	GUIDE ARM PRE-ASSY	1
17	058-0050	NYLON SPACER 1/2IDx3/4ODx1/16"	2	7	005-0532	BELLOWS ASSEMBLY	4
18	058-0060	NYLON SPACER 1/2IDx3/4ODx1/4"	2	8	051-0178	SCREW 1/4"-20 x 5/16" SKT SET S/S	4
				9	051-0250	BOLT 1/4"-20nc. X 1 1/2" S/S	16
				10	051-0422	BOLT 3/8"-16nc. X 3/4" S/S	2

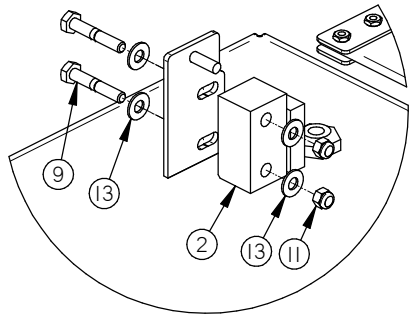

DETAIL A

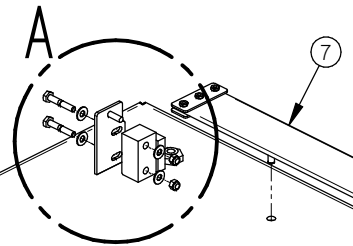

DETAIL B

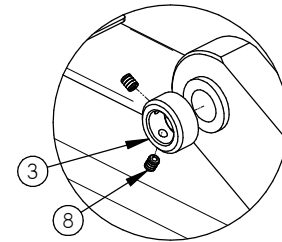

DETAIL C

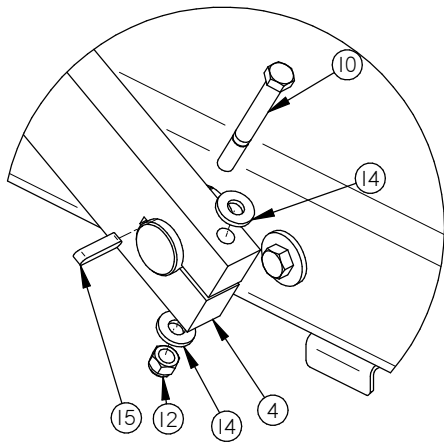
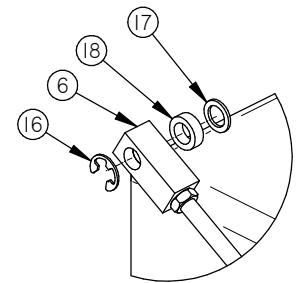

DETAIL E

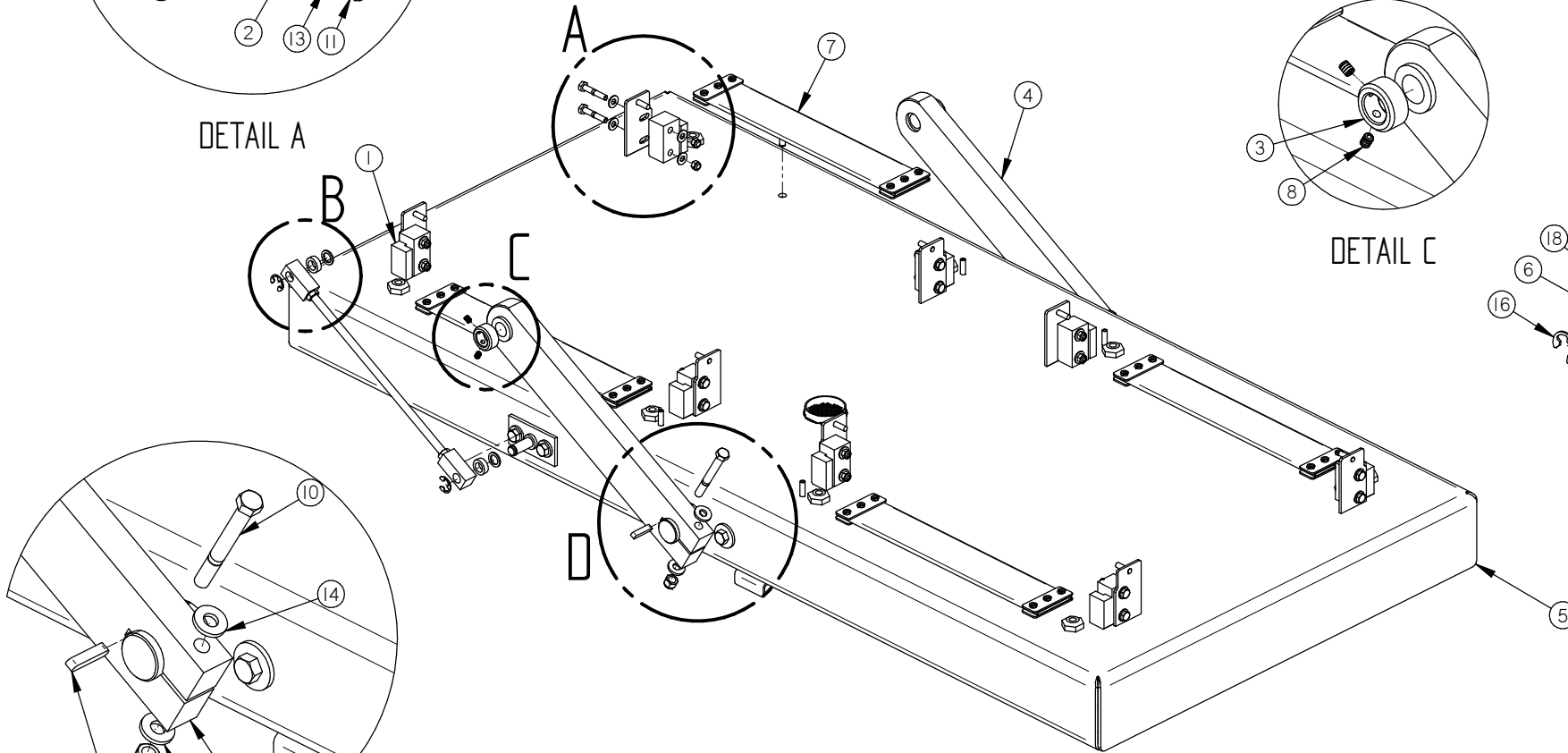

LET.	MODIFICATION	DATE	INT.
------	--------------	------	------

MACHINE	420A		DEPT. TOL.	METRIC	INCH	SIPROMAC ST-GERMAIN DE GRANTHAM QUEBEC CANADA
PART	TABLE ASSY WARM		USINAGE	± 0.1	± 0.004"	
			TOLERIE	± 0.5	± 0.020"	
			SOUDEAGE	± 0.5	± 0.020"	
ITEM	CNC	DEPT.	M	QTY.	1	004A4151
MAT.	DWG BY SBU	DATE 14-01-31	NO.			
	APP. BY	DATE				

004B1393

ITEM	PART #	DESCRIPTION	QT.
1	002-0679	RIGHT GUIDED ARM END	1
2	002A0680	GUIDE ARM ROD	1
3	002-0731	LEFT GUIDED ARM END	1
4	051-0623	HALF NUT 3/8"-24 UNF	1
5	051-0619	HALF NUT 3/8"-24nf. LEFT S/S	1

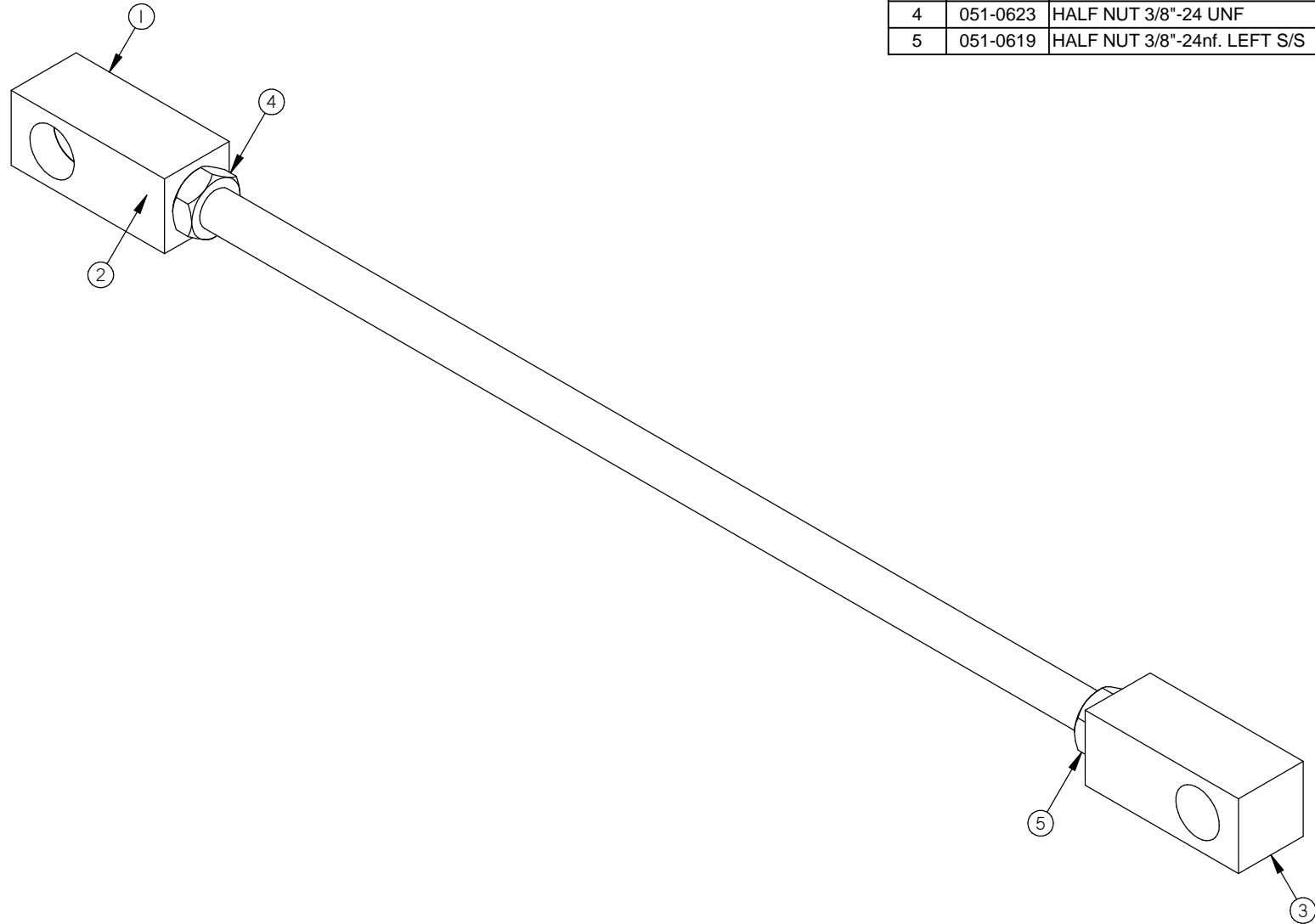

NOTE:

-PASSER AU JET DE SABLE APRÈS AVOIR ASSEMBÉ LES 5 ITEMS.

B	008A0680 WAS 008-0680	14-01-31	SBU
LET.	MODIFICATION	DATE	INT.

MACHINE	420A		DEPT. TOL. METRIC	INCH	SIPROMAC ST-GERMAIN DE GRANTHAM QUEBEC CANADA
PART	GUIDE ARM PRE-ASS'Y		USINAGE ± 0.1 ± 0.004"	TOLERIE ± 0.5 ± 0.020"	
			SOUDEAGE ± 0.5 ± 0.020"	N.T.S.	
ITEM	CNC	DEPT.	U-J(M)		QTY. 1
MAT.	DWG BY SBU	DATE 14-01-31	NO. 004B1393		
	APP. BY	DATE			

004B0124

ITEM	PART #	DESCRIPTION	QT.	ITEM	PART #	DESCRIPTION	QT.
15	036-0400	WIRE CONNECTOR 3/8" NPT NUT	8	1	001A2954	WASHER 0.468"Ø ID x 1.250"OD x 3.5	8
16	051-0142	SCREW 8-32 x1-1/2"RND PHIL S/S	6	2	001A6546	BEARING SPACER	2
17	051-0300	BOLT 5/16"-18 x 3/4" S/S	4	3	002A3941	SPRING ADJ. PIVOT	2
18	051-0360	BOLT 3/8"-16nc. X 1" S/S	2	4	002A4002	SPRING ADJ. PIVOT SPACER	4
19	051-04285	BOLT 7/16-14 x 2" HEX S/S	4	5	002B0324	CENTRAL SHAFT	1
20	051-0560	NUT #8-32 NYLON LOCK S/S	6	6	004A3937	SHACKLE ASS'Y	2
21	051-0600	NUT 5/16" -18 S/S	4	7	004A3968	SPRING INSERT ASSEMBLY	2
22	051-0620	NUT 3/8"-16 NC S/S	2	8	004A4087	SPRING BLOCK PRE-ASSY	1
23	051-0624	NUT 7/16"-14 NYLON LOCK S/S	4	9	005-0317	GUIDE ARM AXIS ASS'Y	1
24	051-0720	WASHER #8 FLAT S/S	6	10	005A1437	MICRO SWITCH COLLAR ASSY	3
25	051-0760	WASHER 5/16" FLAT S/S	4	11	005B0327	TABLE ASEMBLY	1
26	051-0783	WASHER 3/8" FLAT THICK S/S	4	12	008A1953	SPRING	2
27	075-1655	2 BOLT FLANGED BEARING 1-1/4" PLASTIC	2	13	026-0750	ROLLER PLUNGER SWITCH SPDT	3
				14	036-0400	WIRE CONNECT. 3/8" NPT CD09/O-RING/NUT	8

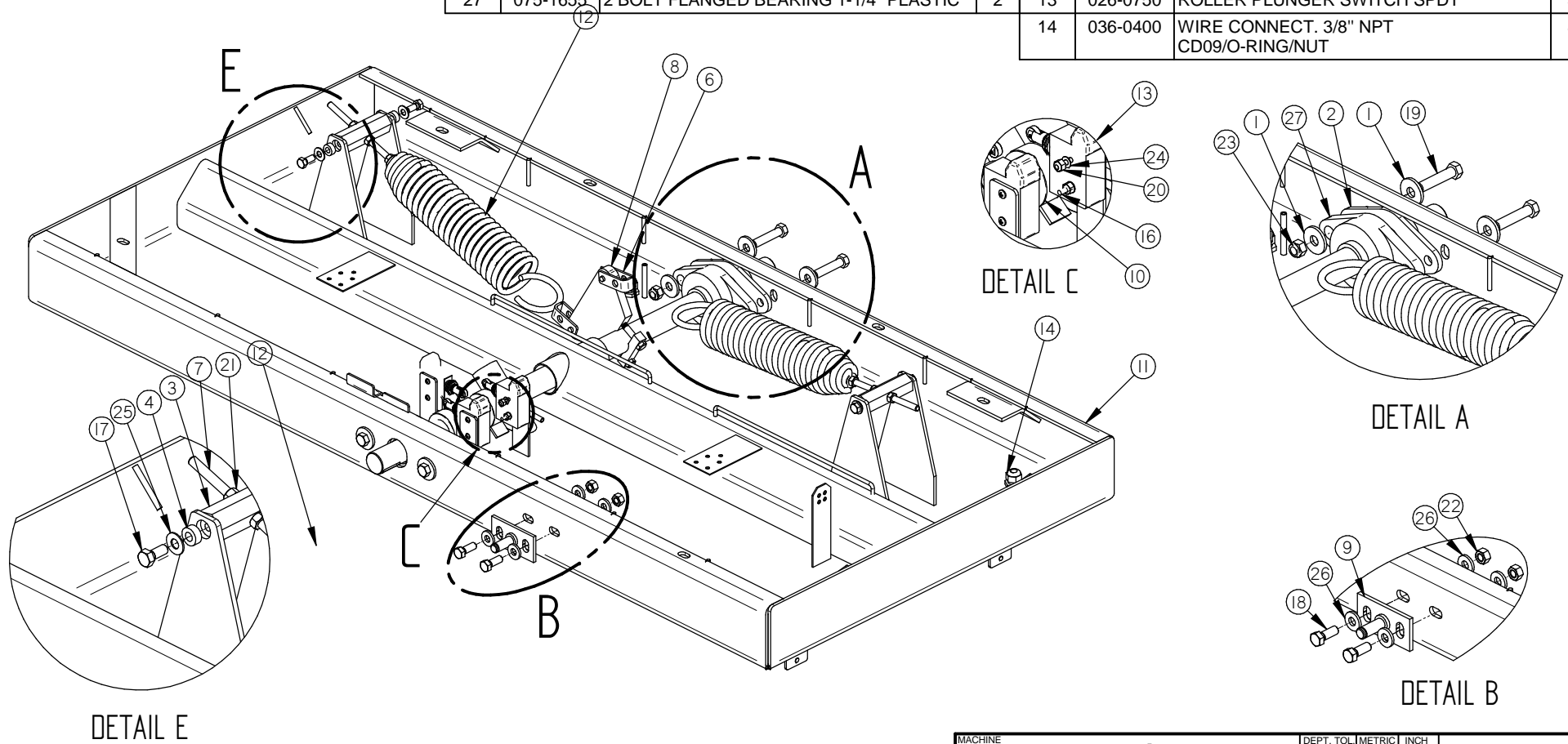

F	EXTENSION SPRING DESIGN	14-01-31	SBU
LET.	MODIFICATION	DATE	INT.

MACHINE	420A	DEPT. TOL. METRIC	INCH	SIPROMAC ST-GERMAIN DE GRANTHAM QUEBEC CANADA
PART	TABLE ASSEMBLY	USINAGE ± 0.1	± 0.004"	
		TOLERIE ± 0.5	± 0.020"	
		SOUDEAGE ± 0.5	± 0.020"	
ITEM	CNC	DEPT.	M	QTY. 1
MAT.	DWG BY SBU	DATE 13-12-18	NO.	004B0124
	APP. BY	DATE		

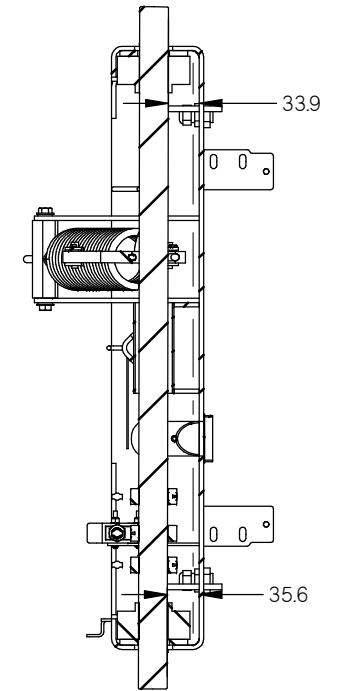
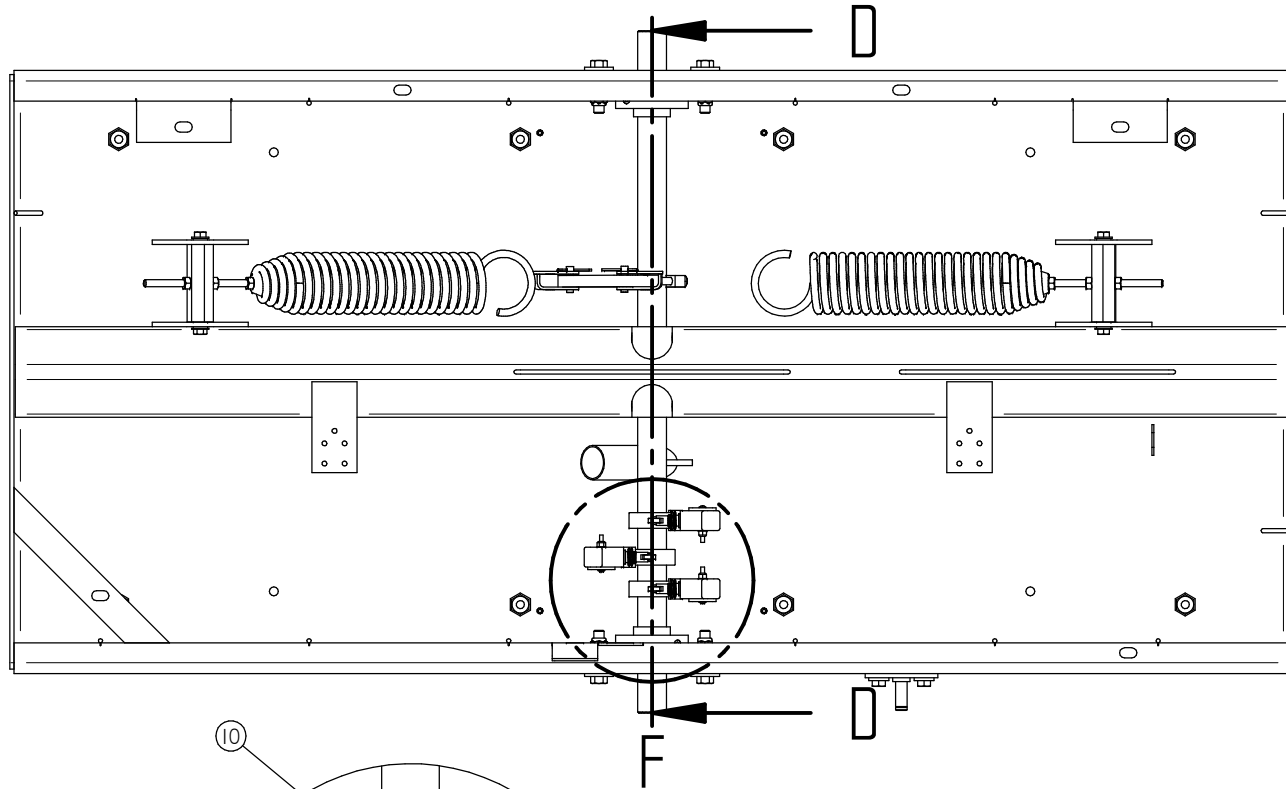

SECTION D-D

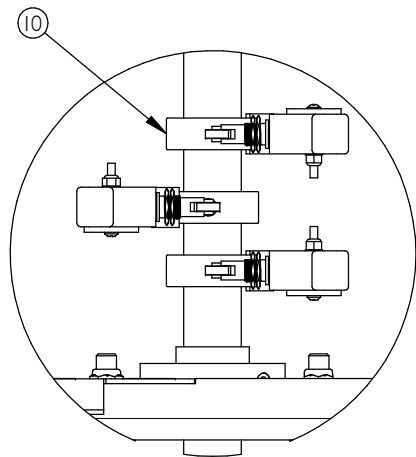

DETAIL F

MACHINE		420A		DEPT. TOL.	METRIC	INCH	SIPROMAC ST-GERMAIN DE GRANTHAM QUEBEC CANADA
PART		TABLE ASSEMBLY		USINAGE	± 0.1	± 0.004"	
ITEM				TOLERIE	± 0.5	± 0.020"	
MAT.				SOUDAGE	± 0.5	± 0.020"	N.T.S.
		CNC		DEPT.		M	QTY. 1
		DWG BY	SBU	DATE	13-12-18	NO.	004B0124
		APP. BY		DATE			

004A3968

ITEM	PART #	DESCRIPTION	QT.
1	002A3989	SPRING ADJUSTMENT ROD	1
2	051-0600	NUT 5/16" -18 S/S	2
3	002B3940	SPRING INSERT	1

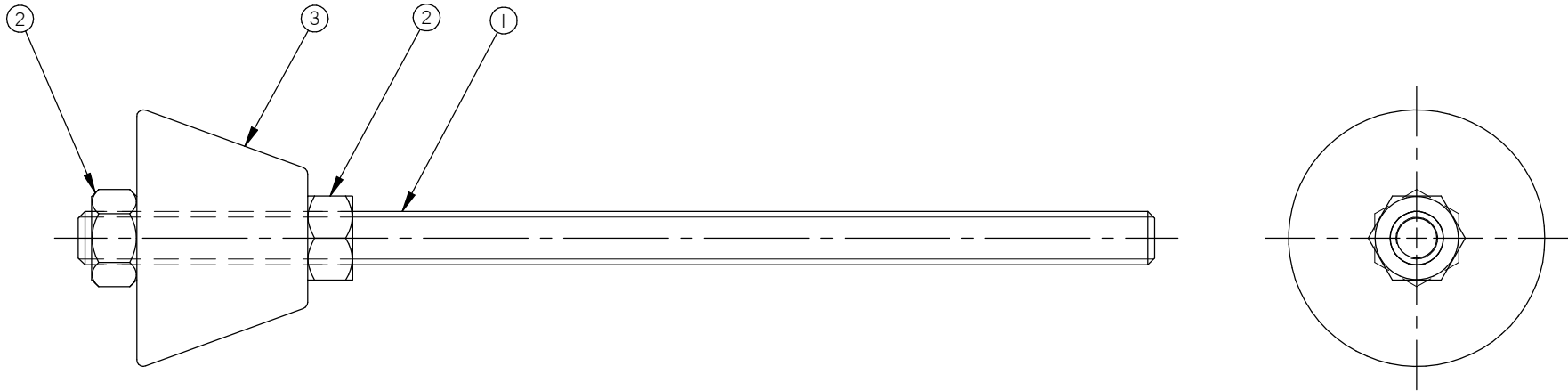

620A	4
600A	4
MACHINE	QTY

MACHINE	600A & 620A			DEPT. TOL.	METRIC	INCH	SIPROMAC ST-GERMAIN DE GRANTHAM QUEBEC CANADA
PART	SPRING INSERT ASSEMBLY			USINAGE	± 0.1	± 0.004"	
				TOLERIE	± 0.5	± 0.020"	
				SOUDEAGE	± 0.5	± 0.020"	N.T.S.
ITEM	CNC	DEPT.	M-(M)	QTY	LISTE		
MAT.	DWG BY J.G.	DATE 13-01-15	NO.	004A3968			
	APP. BY	DATE					

A	AJOUTER 620A	13-01-23	J.G.
LET.	MODIFICATION	DATE	INT.

004A3937

ITEM	PART #	DESCRIPTION	QT.
1	004A3935	SHACKLE PRE-ASS'Y	1
2	001A6269	SHACKLE PLATE	1
3	056-0118	COTTER PIN 3/32" x 1" S/S	1

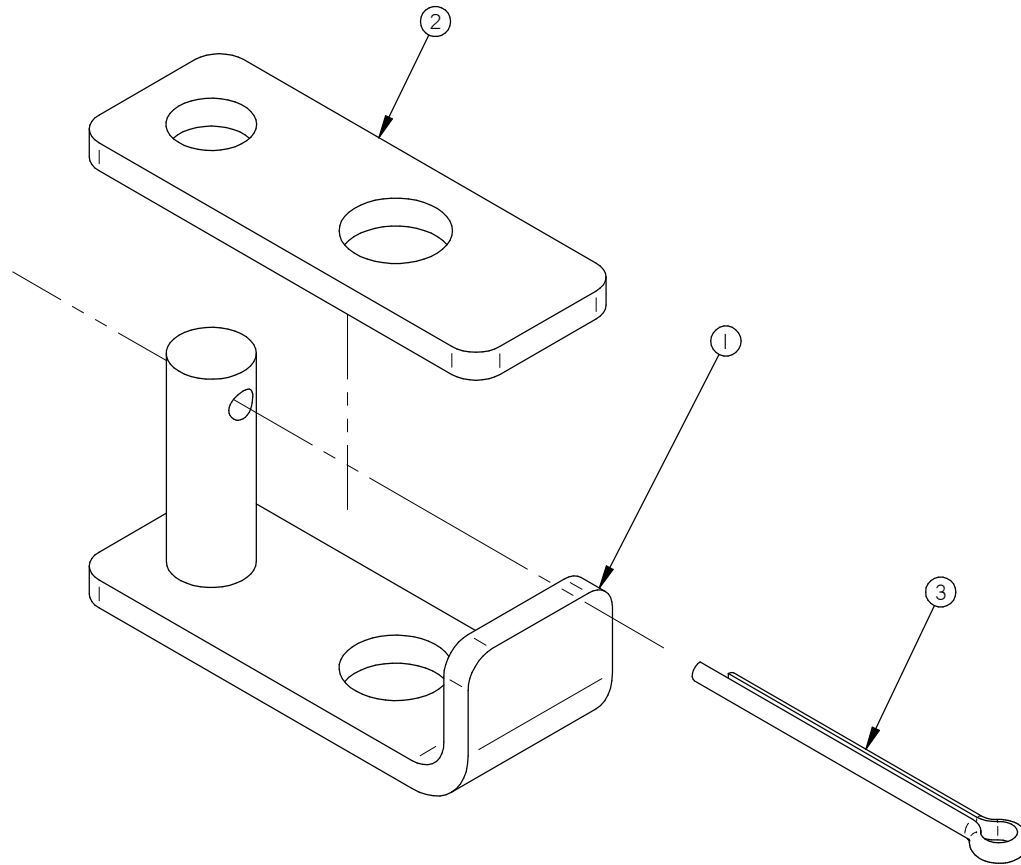

600A	4
MACHINE	QTY

MACHINE		VACUUM		DEPT. TOL.	METRIC	INCH.	SIPROMAC ST-GERMAIN DE GRANTHAM QUEBEC CANADA
PART		SHACKLE ASS'Y		USINAGE	± 0.1	± 0.004"	
ITEM		CNC		TOLERIE	± 0.5	± 0.020"	
MAT.		DWG BY J.G.		DATE	12-11-06		M-(M) QTY LISTE 004A3937
LET.		MODIFICATION		DATE	INT.		

LET.	MODIFICATION	DATE	INT.
------	--------------	------	------

004A4120

ITEM	PART #	DESCRIPTION	QT.
1	001A6589	PUMP SUPPORT	2
2	004B1404	VACUUM / ATMOSPHERE VALVE ASSY.	1
3	051-0360	BOLT 3/8"-16nc. X 1" S/S	8
4	051-0622	NUT 3/8"-16nc. NYLON LOCK S/S	8
5	051-0762	WASHER 5/16" THICK FLAT S/S	4
6	051-0783	WASHER 3/8" FLAT THICK S/S	16
7	051-0980	BOLT M8 x 20 S/S	4
8	104-0125	HOSE 1-1/2" ID VACUUM POLYWIRE (3')	1
9	105-0110	SCREW CLAMPS 1-1/16" TO 2" ALL S/S	1
10	105-0250	EAR CLAMP 1-1/2" S/S	1
11	125-0040	BUSCH RA-0063 230-460V/3PH/60HZ	1
12	125-0041	BUSCH RA0063 380V/3PH/50HZ	1
13	125-0042	BUSCH RA0063 575V/3PH/60HZ	1
14	125-0045	BUSCH RA0063 230-460V/3PH/60HZ OXYGENE	1

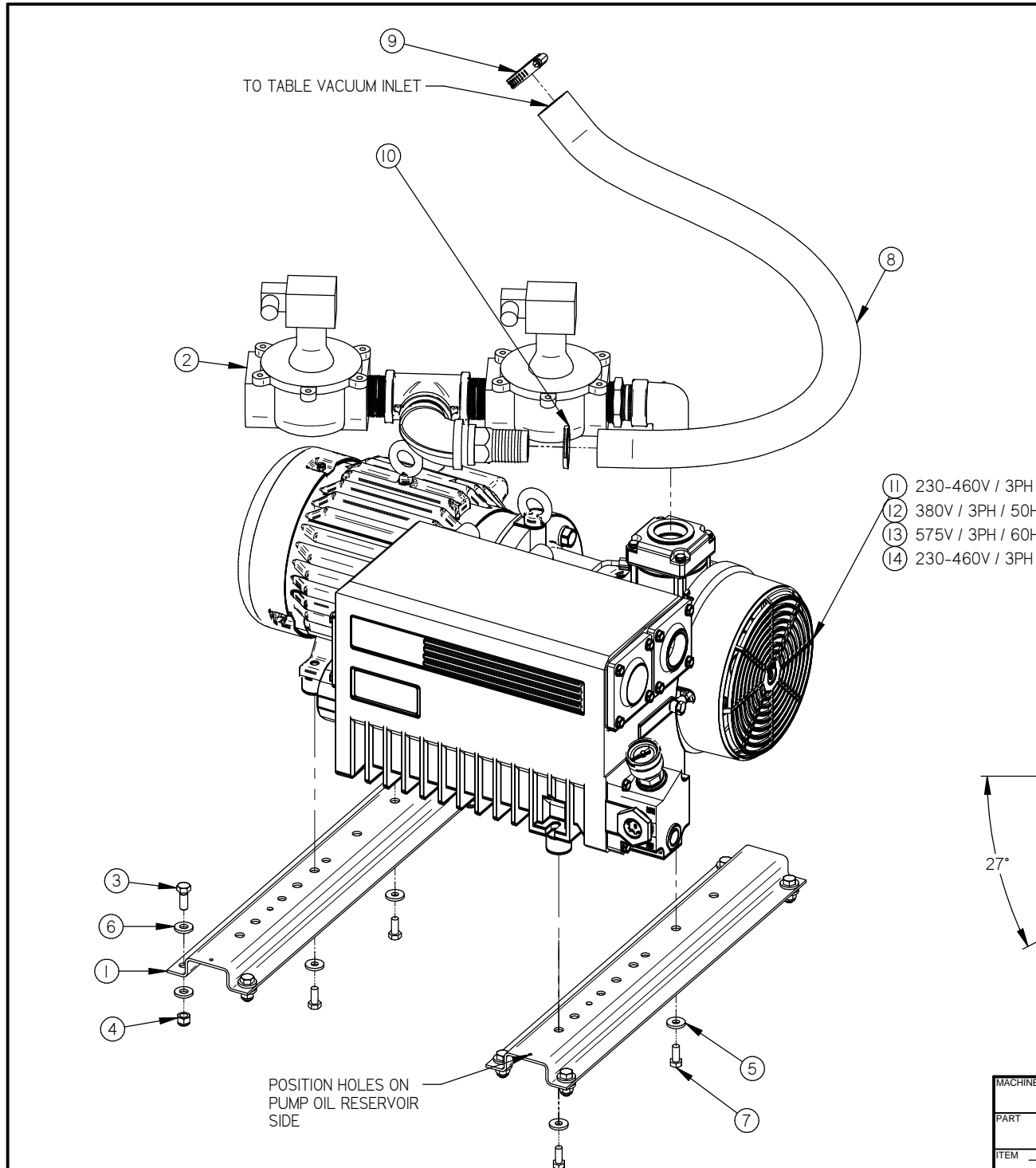

- ⑪ 230-460V / 3PH / 60HZ
- ⑫ 380V / 3PH / 50HZ
- ⑬ 575V / 3PH / 60HZ
- ⑭ 230-460V / 3PH / 60HZ OXYGEN

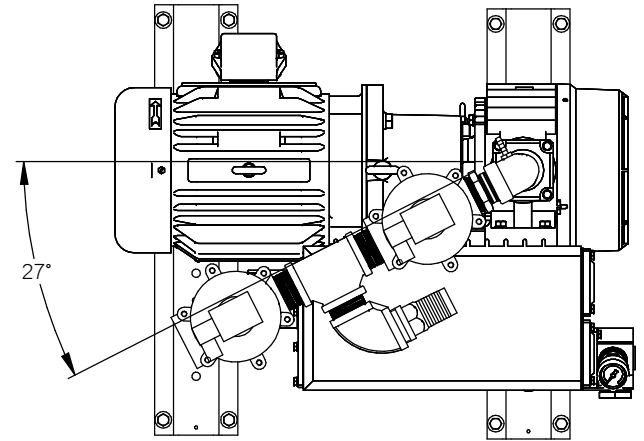

POSITION HOLES ON
PUMP OIL RESERVOIR
SIDE

LET.	MODIFICATION	DATE	INT.
------	--------------	------	------

MACHINE	420A		DEPT. TOL. METRIC	INCH	SIPROMAC ST-GERMAIN DE GRANTHAM QUEBEC CANADA
PART	PUMP "BUSCH" 63M³ ASSY		USINAGE ± 0.1	± 0.004"	
			TOLERIE ± 0.5	± 0.020"	
ITEM	CNC	DEPT.	N.T.S.		QTY. 1
MAT.	DWG BY SBU	DATE 14-01-28	NO. 004A4120		
	APP. BY	DATE			

004A4119

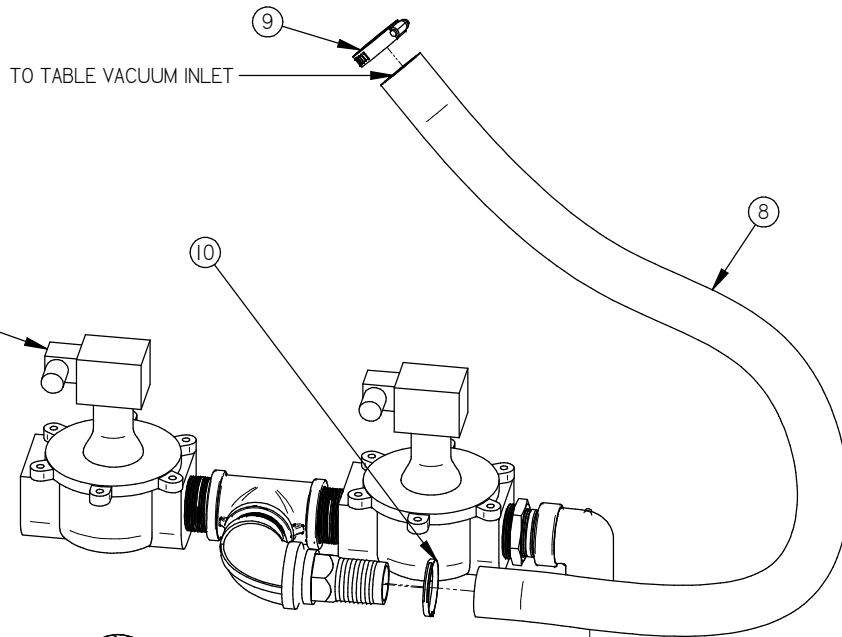

ITEM	PART #	DESCRIPTION	QT.
1	001A6589	PUMP SUPPORT	3
2	004B1404	VACUUM / ATMOSPHERE VALVE ASSY.	1
3	051-0360	BOLT 3/8"-16nc. X 1" S/S	12
4	051-0622	NUT 3/8"-16nc. NYLON LOCK S/S	12
5	051-0762	WASHER 5/16" THICK FLAT S/S	4
6	051-0783	WASHER 3/8" FLAT THICK S/S	24
7	051-0980	BOLT M8 x 20 S/S	4
8	104-0125	HOSE 1-1/2" ID VACUUM POLYWIRE	1
9	105-0110	SCREW CLAMPS 1-1/16" TO 2" ALL S/S	1
10	105-0250	EAR CLAMP 1-1/2" S/S	1
11	125-0030	BUSCH RA-0040 230-460V/3PH/60HZ	1
12	125-0032	BUSCH RA-0040 575V/3PH/60Hz	1
13	125-0034	BUSCH RA0040 220V/1PH/60Hz	1

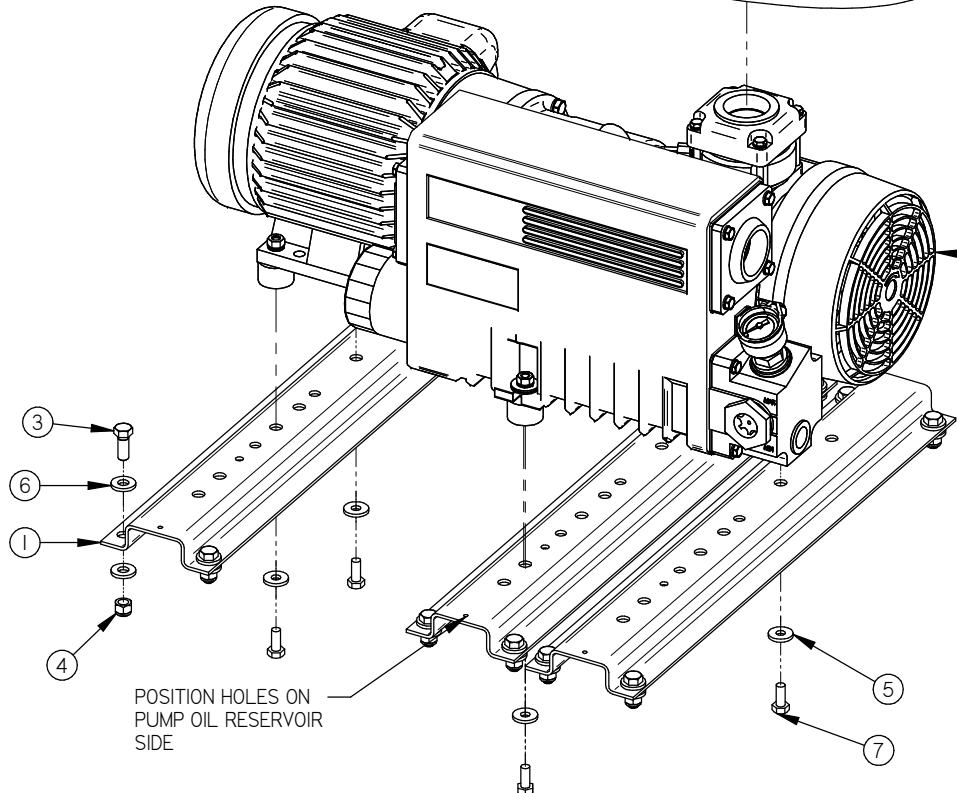

- (13) 220V / 1PH
- (12) 575V / 3PH
- (11) 230-460V / 3PH

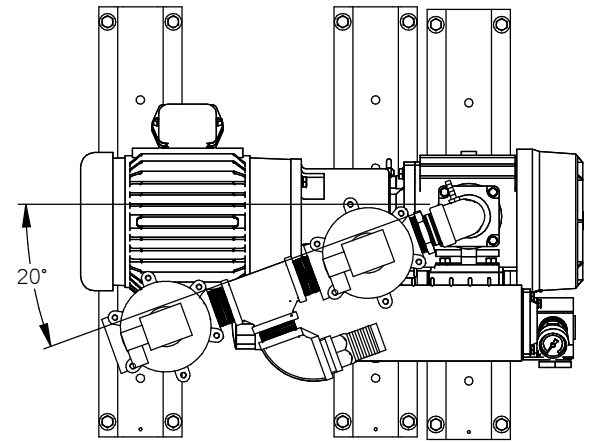

LET.	MODIFICATION	DATE	INT.
------	--------------	------	------

MACHINE		420A		DEPT. TOL. METRIC	INCH	SIPROMAC ST-GERMAIN DE GRANTHAM QUEBEC CANADA
PART		PUMP "BUSCH" 40M³ ASSY		USINAGE ± 0.1	± 0.004"	
ITEM		CNC		TOLERIE ± 0.5	± 0.020"	
MAT.		APP. BY SBU		DATE 14-01-27	NO. 004A4119	DEPT. M QTY. 1

004B1404

ITEM	PART #	DESCRIPTION	QT.
1	004A4081	BELLOWS ELBOW CONNECTOR ASSY	1
2	100-0245	CLOSE NIPPLE 1 1/4"npt. S/S	1
3	106-0051	VALVE 2WAY 24V 1-1/2"NPT60Hz	2
4	100-0485	TEE 1-1/2" NPT S/S	1
5	100-0440	NIPPLE 1-1/2" NPT X 2" SS	3
6	100-0047	ELBOW 90° X 1-1/2" NPT S/S	1
7	100-1230	STRAIGHT 1-1/2"MNPT x1-1/2" HOSE BARB	1
8	100-0555	RED.BUSH.1-1/2" x 1-1/4" NPT S/S	1

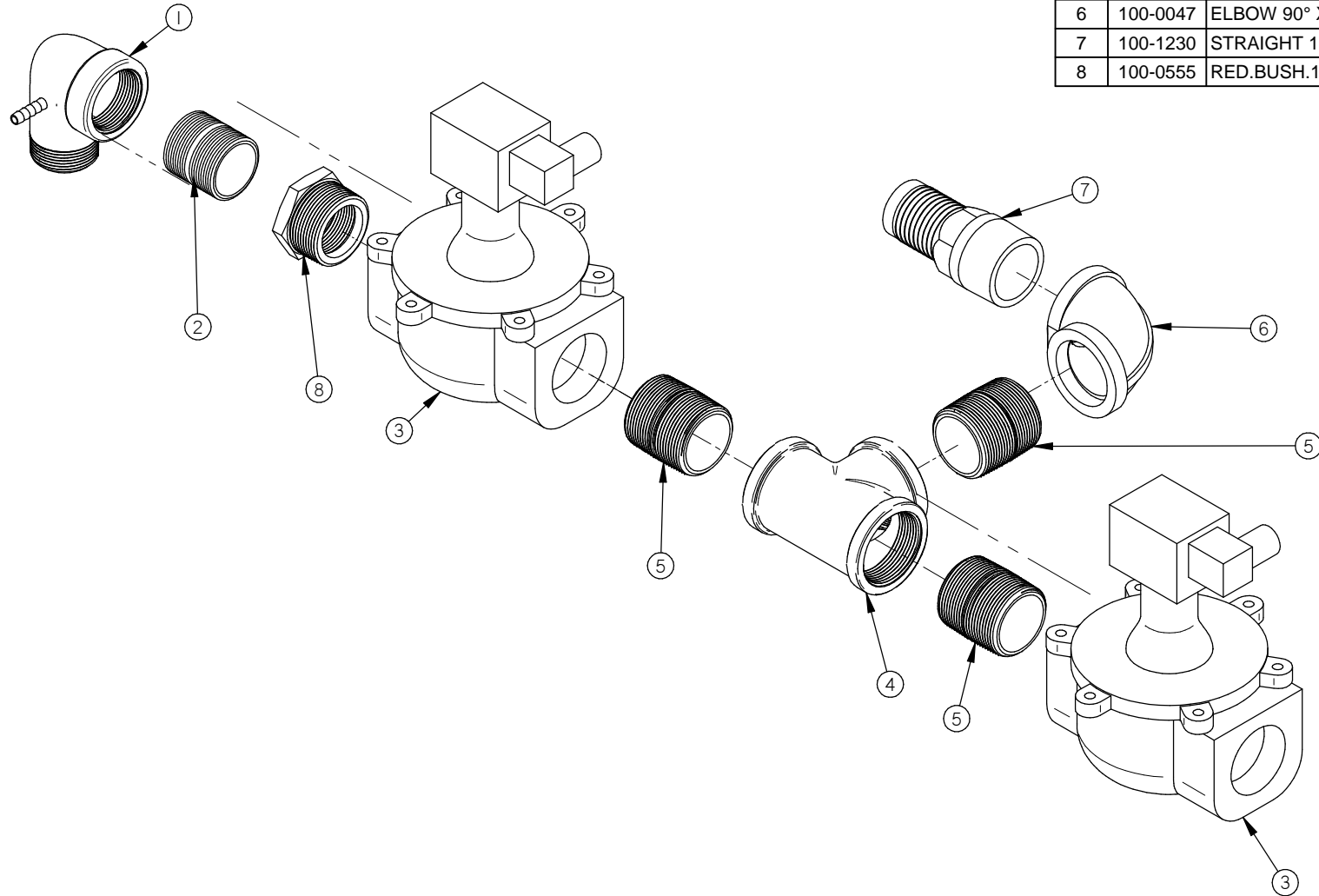

-OPTION - 40M³, 63M³ & 100M³ PUMP

MACHINE		DEPT. TOL. METRIC		INCH		SIPROMAC	
VACUUM		USINAGE	± 0.1	± 0.004"			
PART		TOLERIE	± 0.5	± 0.020"	ST-GERMAIN DE GRANTHAM		
VACUUM / ATMOSPHERE VALVE ASSY.		SOUDEAGE	± 0.5	± 0.020"	QUEBEC CANADA		
ITEM	CNC	N.T.S.		DEPT.	M-I	QTY.	1
MAT.	DWG BY	SBU	DATE	13-09-19	NO. 004B1404		
	APP. BY		DATE				

LET.	MODIFICATION	DATE	INT.
------	--------------	------	------

004A4121

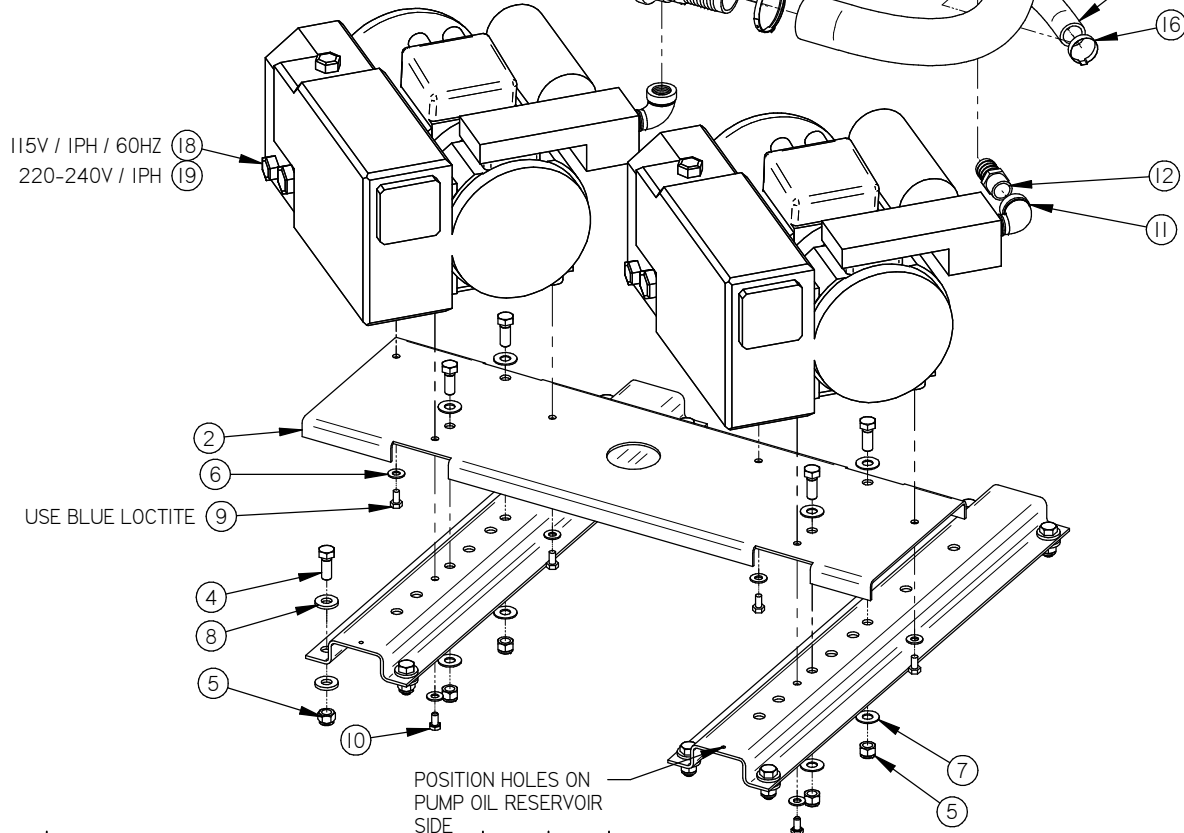
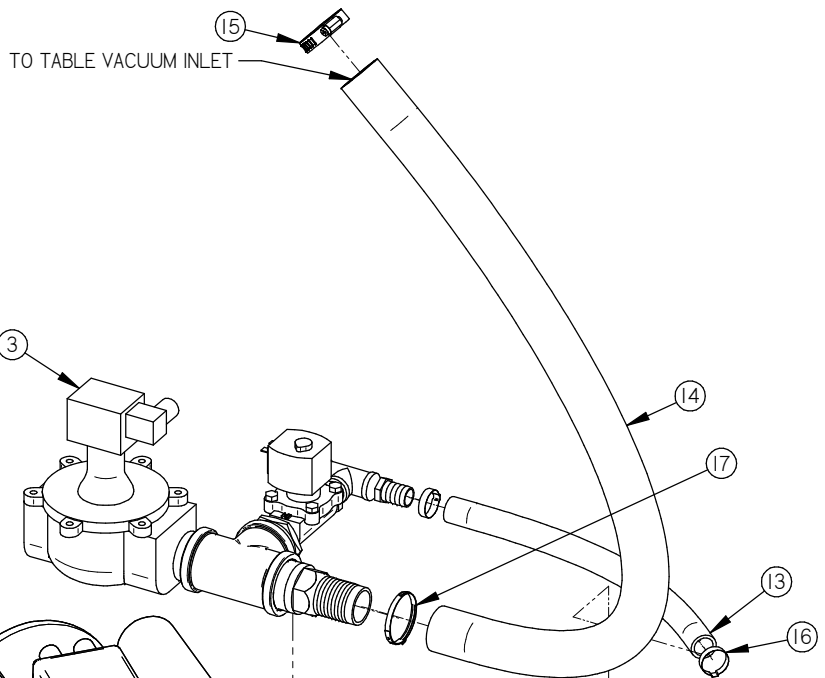

ITEM	PART #	DESCRIPTION	QT.
1	001A6589	PUMP SUPPORT	2
2	001A6590	KB-0020 TRANSVERSE PUMP SUPPORT	1
3	004A4153	VACUUM/ATMOSPHERE VALVE ASSY (2X KB0020)	1
4	051-0360	BOLT 3/8"-16nc. X 1" S/S	12
5	051-0622	NUT 3/8"-16nc. NYLON LOCK S/S	12
6	051-0740	WASHER 1/4" FLAT S/S	6
7	051-0780	WASHER 3/8" FLAT S/S	8
8	051-0783	WASHER 3/8" FLAT THICK S/S	16
9	051-0930	BOLT M6 x 10 S/S	4
10	051-0948	BOLT M6 x 12 SS	2
11	100-0075	STREET ELBOW 1/2" NPT SS	2
12	100-1205	STRAIGHT 1/2" MNPTx3/4" HOSE BARB S/S	1
13	104-0110	HOSE 3/4" ID VACUUM TIGERFLEX (1.02')	1
14	104-0125	HOSE 1-1/2" ID VACUUM POLYWIRE (3')	1
15	105-0110	SCREW CLAMPS 1-1/16" TO 2" ALL S/S	1
16	105-0238	EAR CLAMP 23.9-27.1 SS	2
17	105-0250	EAR CLAMP 1-1/2" S/S	1
18	125-1020	BUSCH KB-0020 115V/1PH/60HZ	2
19	125-1021	BUSCH KB-0020 220-240V/1PH/50-60HZ	2

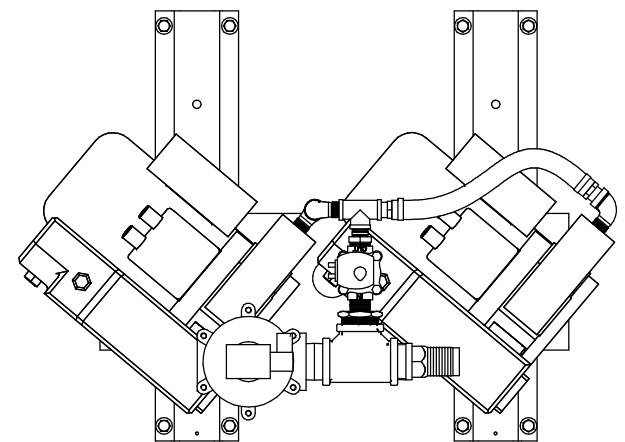

LET.	MODIFICATION	DATE	INT.
------	--------------	------	------

MACHINE		420A		DEPT. TOL. METRIC	INCH.	SIPROMAC ST-GERMAIN DE GRANTHAM QUEBEC CANADA
PART		PUMP "BUSCH" 2X 20M³		USINAGE ± 0.1	± 0.004"	
ITEM		CNC		TOLERIE ± 0.5	± 0.020"	
MAT.		APP. BY SBU		DATE 14-01-28	NO. 004A4121	DEPT. M QTY. 1

004A4153

ITEM	PART #	DESCRIPTION	QT.
1	100-0075	STREET ELBOW 1/2" NPT SS	1
2	100-0230	CLOSE NIPPLE 1/2" npt, S/S	1
3	100-0235	CLOSE NIPPLE 3/4"npt, S/S	1
4	100-0250	CLOSE NIPPLE 1-1/2"NPT S/S	1
5	100-0325	NIPPLE 1/2"npt. X 2" S/S	1
6	100-0465	TEE 1/2"npt. S/S	1
7	100-0485	TEE 1-1/2" NPT S/S	1
8	100-0520	RED.BUSH.3/4"NPT x 1/2"NPT S/S	1
9	100-0553	REDUCING BUSH. 1-1/2" NPT X 3/4" NPT SS	1
10	100-1205	STRAIGHT 1/2"MNPTx3/4" HOSE BARB S/S	1
11	100-1230	STRAIGHT 1-1/2"MNPT x1-1/2" HOSE BARB	1
12	106-0030	VALVE 2WAY 24V 3/4"NPT(G95) 60Hz	1
13	106-0051	VALVE 2WAY 24V 1-1/2"NPT60Hz	1

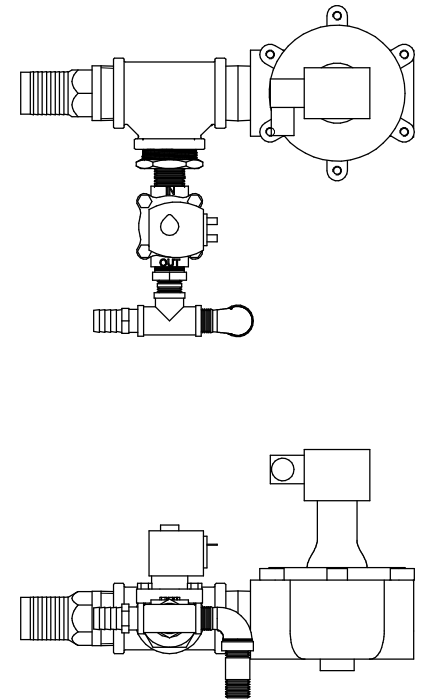
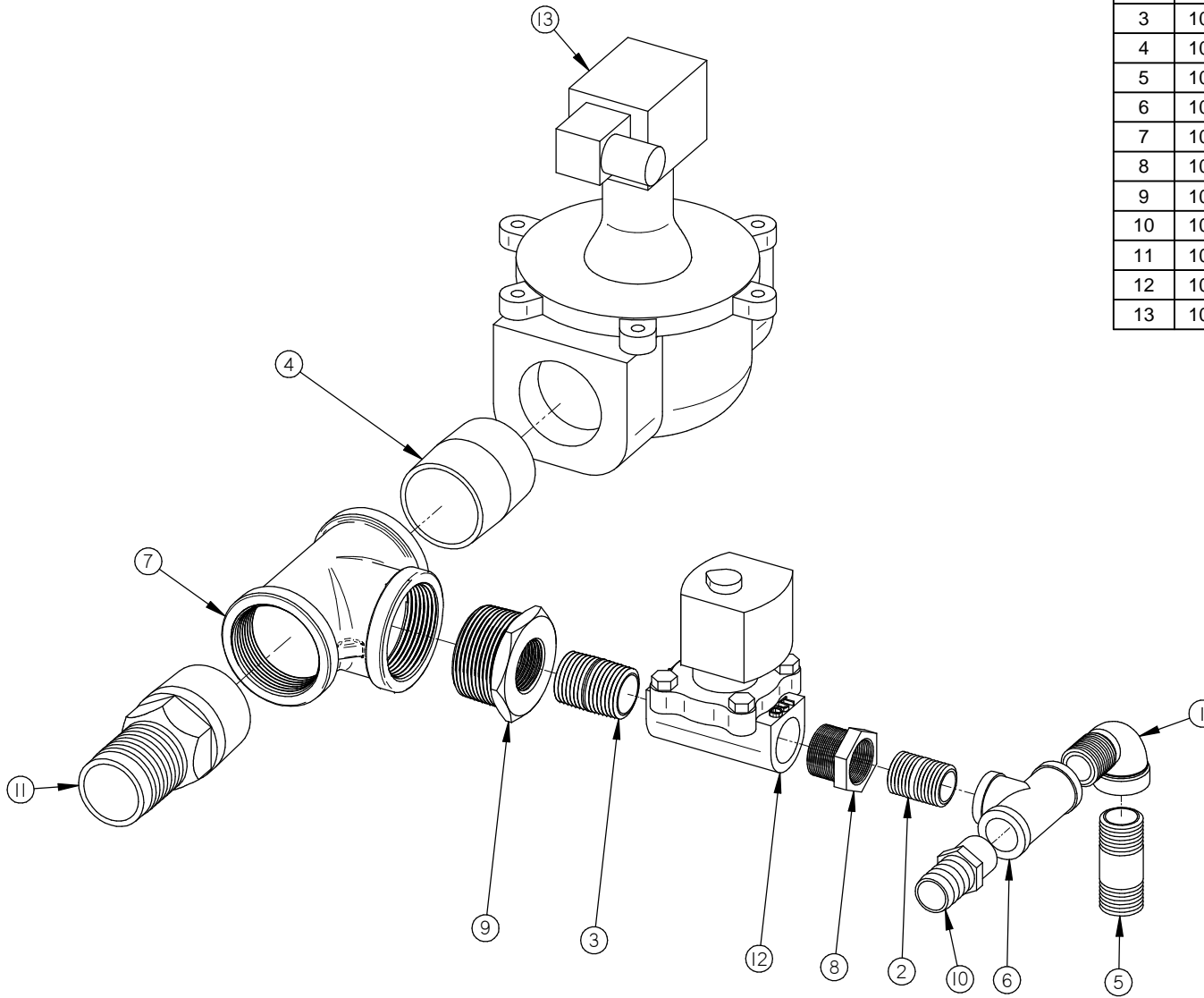

LET.	MODIFICATION	DATE	INT.
------	--------------	------	------

MACHINE		VACUUM		DEPT. TOL	METRIC	INCH	SIPROMAC ST-GERMAIN DE GRANTHAM QUEBEC CANADA
PART		VACUUM/ATMOSPHERE VALVE ASSY (2X KB0020)		USINAGE	± 0.1	± 0.004"	
				TOLERIE	± 0.5	± 0.020"	
ITEM		CNC		SOUDEAGE	± 0.5	± 0.020"	N.T.S.
MAT.		DWG BY	SBU	DATE	14-01-28	NO.	1
		APP. BY		DATE		NO.	004A4153

005A1355

ITEM	PART #	DESCRIPTION	QT.
1	004-0352	SEAL BAR PRE-ASSEMBLY	1
2	002-0512	SEAL BAR SUPPORT	1
3	051-0256	BOLT 1/4"-20nc. X 1 3/4" CAP SKT S/S	3
4	001-1960	EXTERIOR BELLOWS COVER	1
5	001-1856	EXTERIOR BELLOWS COVER	1
6	001A6229	SEAL BAR GUIDE	2
7	051-0740	WASHER 1/4" FLAT S/S	10
8	051-0250	BOLT 1/4"-20nc. X 1 1/2" S/S	4
9	051-0581	NUT 1/4"-20 NYLON LOCK S/S	6
10	051-0230	HEX BOLT 1/4-20 x 1 1/4" SS	2

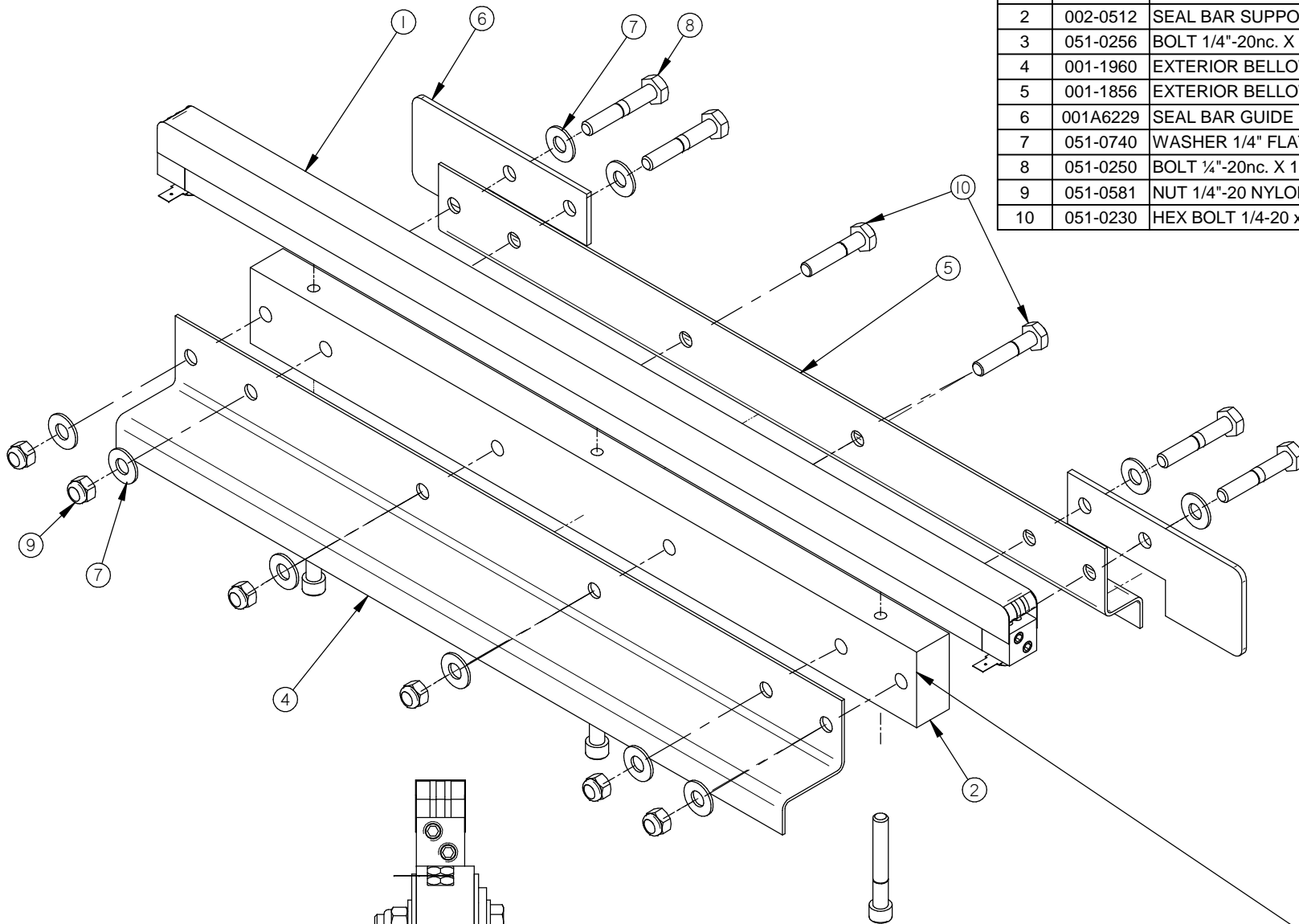

-ITEM #2 ÉGAL AVEC L'ITEM #4 & #5.
-ITEM #2 FLUSH WITH ITEM #4 & #5.

-END VIEW-

-CE COTÉ DU SUPPORT ÉGAL AVEC DE LA BARRE DE SCELLAGE.
-THIS SIDE OF SUPPORT TO FIT FLUSH W/ SEAL BAR.

-TWIN SEAL OPTION-

420A	4
350D	2
350	1
300D	2
300	1
MACHINE	QTY

MACHINE	300, 300D, 350, 350D & 420A		DEPT. TOL. METRIC	INCH	 ST-GERMAIN DE GRANTHAM QUEBEC CANADA	
PART	SEAL BAR ASSEMBLY W/SUPP. TWIN SEAL		USINAGE	± 0.1		± 0.004
			TOLERIE	± 0.5		± 0.020
ITEM		PROGRAM				
MAT.		3D BY	J.G.	DATE	12-09-24	
		2D BY		DATE		
			N.T.S.		NO. 005A1355	
			M-I-(M) LIST			

B	AJOUT 420A ÉTAIT ÉTAIT 005B0046	14-08-21	SBU
A	REDESSINE ÉTAIT 005B0046	12-09-24	J.G.
LET.	MODIFICATION	DATE	INT.

1004-0352

ITEM	#PART	DESCRIPTION	QT.
1	002-0481	SEAL BAR (TABLE)	1
2	002-0031	CONNECTOR	2
3	039-0200	SEALING ELEM. STD TWIN (2x626mm EA.)	4.31
4	052-0395	SCREW 1/4"-20 NC. X 5/16" SET HEX SKT OVAL PT	4
5	052-0250	SCREW #8-32 X 1 1/2" RND SLOT BRASS	2
6	051-0550	NUT #8-32 S/S	4
7	176-0200	TEFLON TAPE 5S ADHESIVE X 2" X (496mm EA.)	0.063
8	027-0400	CONNECTOR ADAPTOR 1/4" X #10 STUD	2

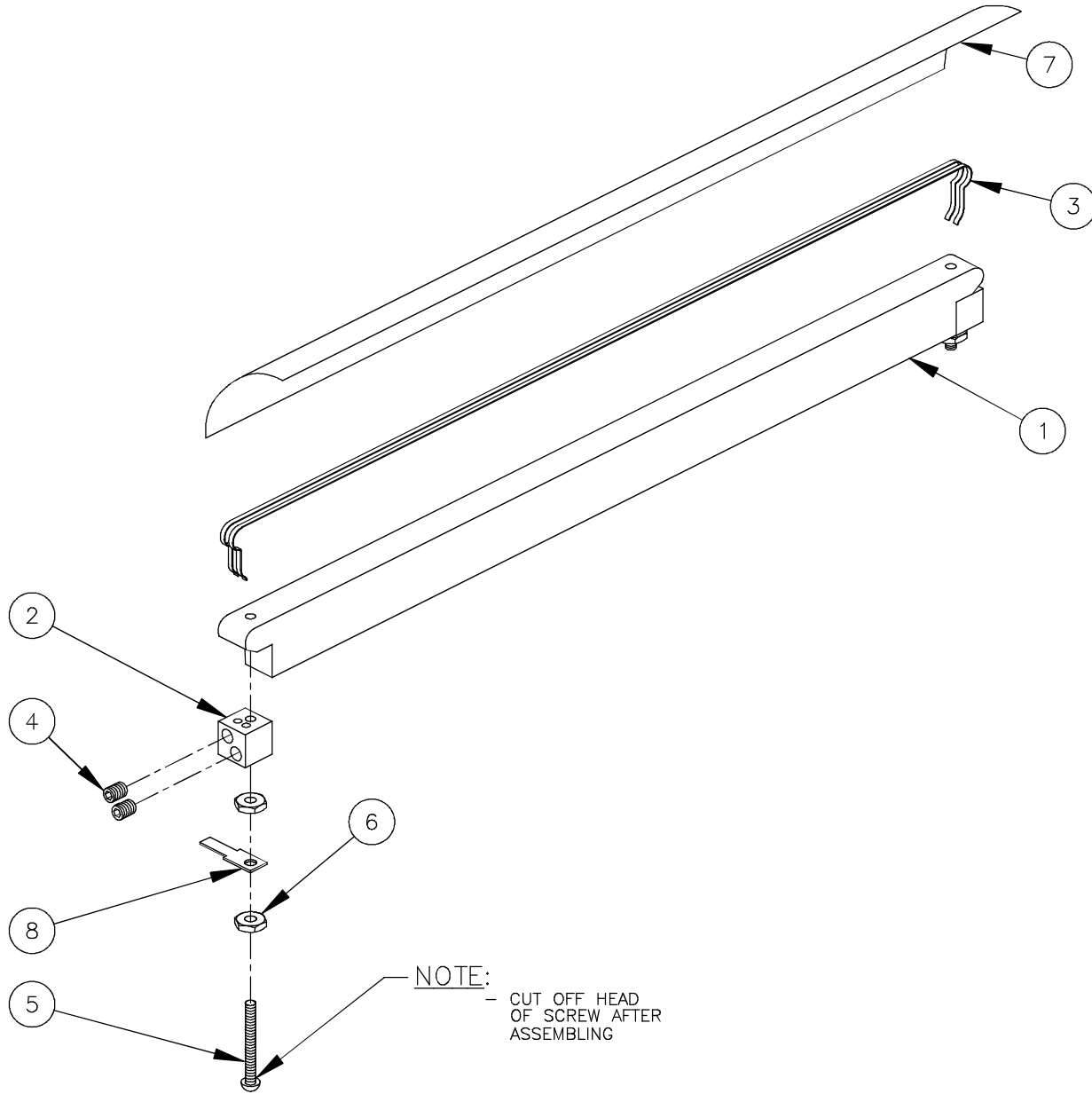

420A	4
450T	2
450A	2
400	2
350D	2
350	1
300D	2
300	1
MACHINE	QTÉ.

G	ADDED 420A WAS 005-0267	14-08-21	SBU
F	ADDED 300, 300D, 350 & 350D WAS 005-0267	12-09-24	J.G.
E	ADDED 450T WAS 005-0377	08-05-26	D.A.
D	MODIFICATION #A-0398 (CONNECTEUR)	04-04-19	J.G.
C	ADDED 400	99-05-06	S.L.
B	REDRAWN	98-02-10	A.P.
LET.	MODIFICATION	DATE	INT.

MACHINE		TOLERANCE		SIPROMAC	
VOIR LISTE		METRIC	INCH	ST-GERMAIN DE GRANTHAM, QUEBEC CANADA	
PART		USINAGE ± 0.1	± 0.004"	M-1	
SEAL BAR PRE-ASSEMBLY		TOLERIE ± 0.5	± 0.020"	qt.	2
ITEM:		CNC:	DATE	NO. 004-0352	
MAT:		DWG BY A. P.	DATE 98-02-10		
		APP.	DATE		

004B0126

ITEM	PART #	DESCRIPTION	QT.
1	002B0406	UPPER SEAL BAR	1
2	008A0316	UPPER SEAL BAR RUBBER	1
3	171-0180	TAPE CLEAR SUPER BOND 3/4" 600mm (0.017)	2
4	176-0200	TEFLON TAPE,PRESS.SENSITIVE 2" 600mm (0.06)	1

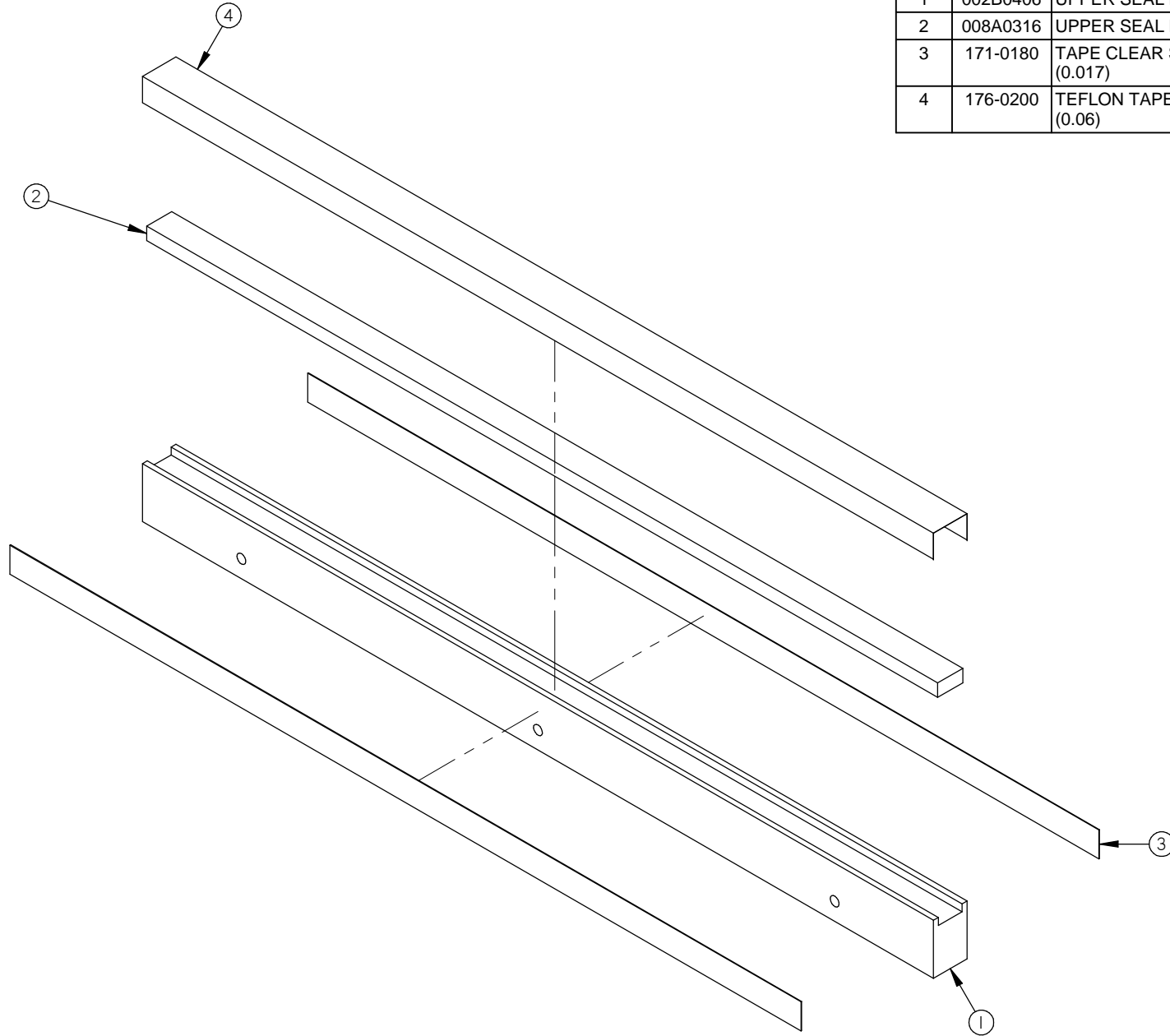

LET.	MODIFICATION	DATE	INT.
------	--------------	------	------

MACHINE	420A		DEPT. TOL.	METRIC	INCH	SIPROMAC ST-GERMAIN DE GRANTHAM QUEBEC CANADA
PART	UPPER SEAL BAR ASSY		USINAGE	± 0.1	± 0.004"	
			TOLERIE	± 0.5	± 0.020"	
			SOUDEAGE	± 0.5	± 0.020"	N.T.S.
ITEM	CNC	DEPT.	M	QTY.	2	004B0126
MAT.	DWG BY SBU	DATE 14-01-29	NO.			
	APP. BY	DATE				

005A1356

ITEM	PART #	DESCRIPTION	QT.
1	004-0355	BAG CUT SEAL BAR PRE-ASSEMBLY	1
2	002-0512	SEAL BAR SUPPORT	1
3	051-0256	BOLT 1/4"-20nc. X 1 3/4" CAP SKT S/S	3
4	001-1960	EXTERIOR BELLOWS COVER	1
5	001-1856	EXTERIOR BELLOWS COVER	1
6	001A6229	SEAL BAR GUIDE	2
7	051-0740	WASHER 1/4" FLAT S/S	10
8	051-0250	BOLT 1/4"-20nc. X 1 1/2" S/S	4
9	051-0581	NUT 1/4"-20 NYLON LOCK S/S	6
10	051-0230	HEX BOLT 1/4-20 x 1 1/4" SS	2

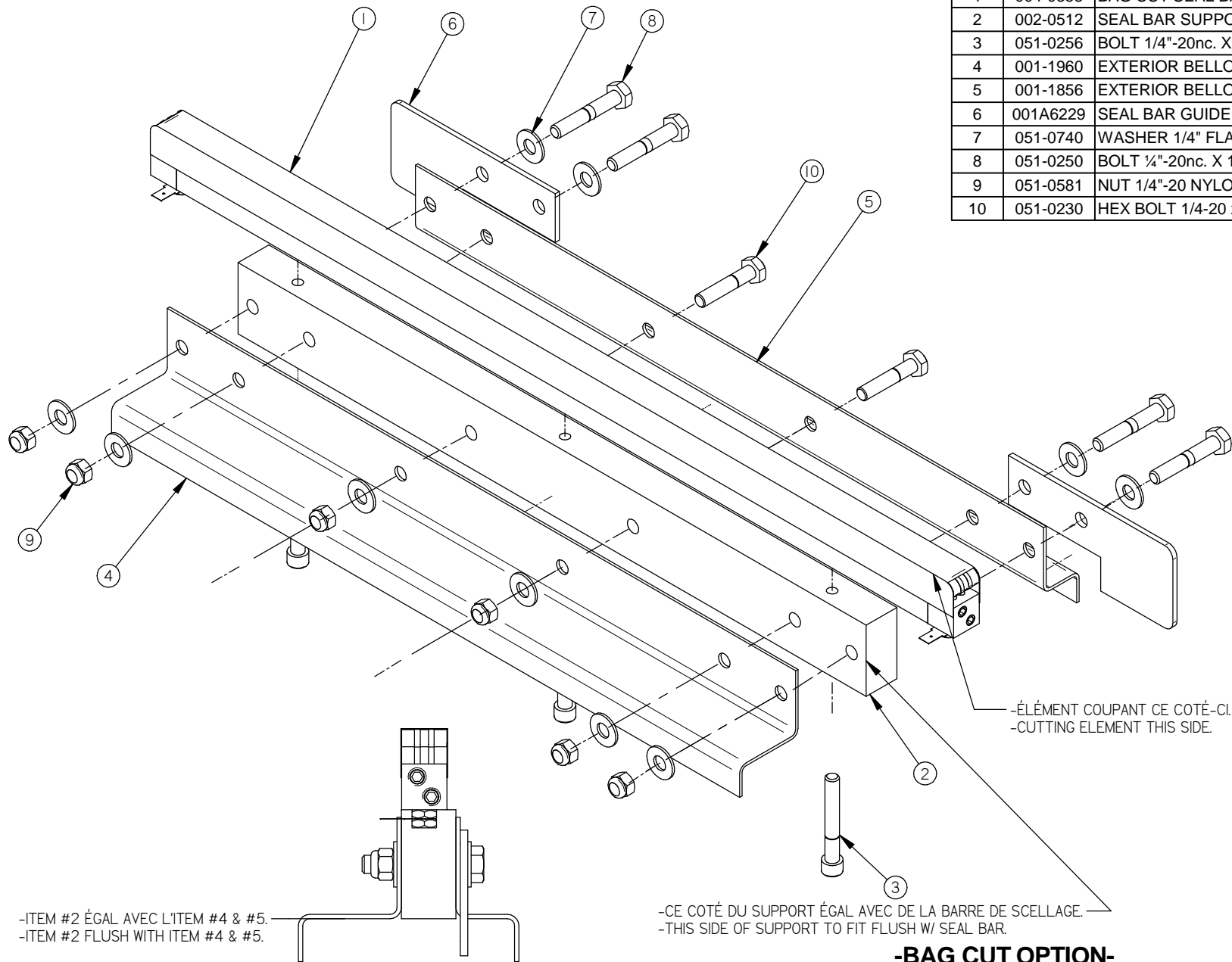

-ITEM #2 ÉGAL AVEC L'ITEM #4 & #5.
-ITEM #2 FLUSH WITH ITEM #4 & #5.

-CE COTÉ DU SUPPORT ÉGAL AVEC DE LA BARRE DE SCELLAGE.
-THIS SIDE OF SUPPORT TO FIT FLUSH W/ SEAL BAR.

-BAG CUT OPTION-

-END VIEW-

420A	4
350D	2
350	1
300D	2
300	1
MACHINE	QTY

MACHINE	300, 300D, 350, 350D & 420A		DEPT. TOL. METRIC	INCH
PART	SEAL BAR ASSEMBLY W/SUPP. BAG CUT		USINAGE	± 0.1 ± 0.004
ITEM	PROGRAM	DEPT.	TOLERIE	± 0.5 ± 0.020
MAT.	3D BY J.G.	DATE 12-09-24	SOUDAGE	± 0.5 ± 0.020
			N.T.S.	
			ST-GERMAIN DE GRANTHAM QUEBEC CANADA	
			M-I-(M) LIST	
			NO. 005A1356	

B	AJOUT 420A ÉTAIT 005B0558	14-08-21	SBU
A	REDESSINÉ ÉTAIT 005B0558	12-09-24	J.G.
LET.	MODIFICATION	DATE	INT.

1004-0355

ITEM	#PART	DESCRIPTION	QT.
1	002-0481	SEAL BAR	1
2	002-0031	CONNECTOR	2
3	039-0230	REFLEX BAND 2.5MM (626mm EA.)	0.063
4	039-0270	"T" PROFILE CUT. ELEM. (626mm EA.)	0.063
5	052-0395	SCREW 1/4"-20 NC. X 5/16" SET HEX SKT OVAL PT	4
6	052-0250	SCREW #8-32 X 1 1/2" RND SLOT BRASS	2
7	051-0550	NUT #8-32 S/S	4
8	176-0200	TEFLON TAPE 5S ADHESIVE X 2" X (496mm EA.)	0.063
9	027-0400	CONNECTOR ADAPTOR 1/4" X #10 STUD	2

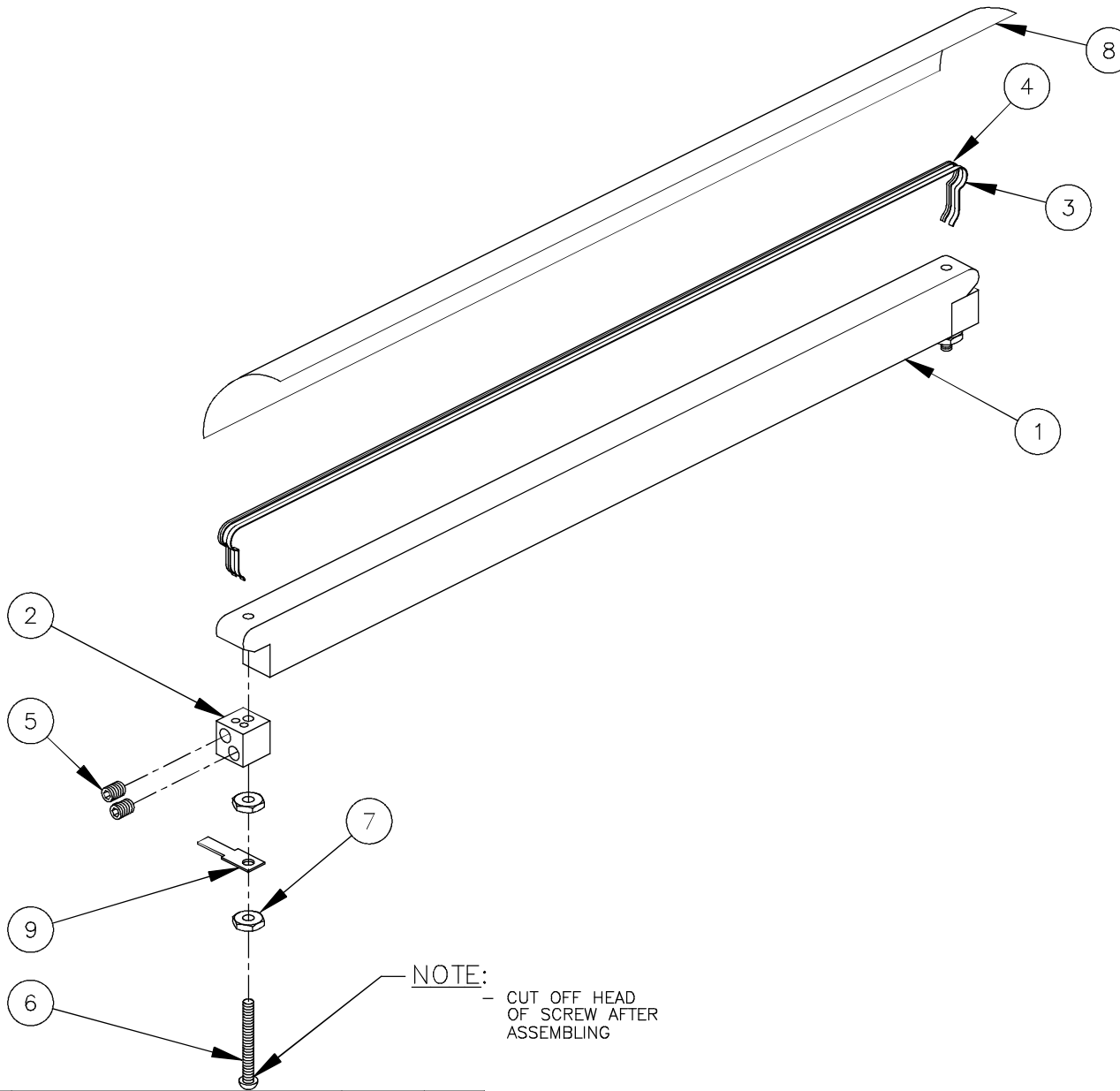

NOTE: - CUT OFF HEAD OF SCREW AFTER ASSEMBLING

-BAG CUT OPTION-

420A	4
450T	2
450A	2
400	2
350D	2
350	1
300D	2
300	1
MACHINE	QTÉ.

G	ADDED 420A WAS 005-0267	14-08-21	SBU
F	ADDED 300, 300D, 350 & 350D WAS 005-0267	12-09-24	J.G.
E	ADDED 450T WAS 005-0383	08-05-26	D.A.
D	MODIFICATION #A-0398 (CONNECTEUR)	04-04-19	J.G.
C	ADDED 400	99-05-06	S.L.
B	REDRAWN	98-02-10	A.P.
LET.	MODIFICATION	DATE	INT.

MACHINE	VOIR LISTE			<table border="1"> <thead> <tr> <th colspan="2">TOLERANCE</th> <th>INCH</th> </tr> </thead> <tbody> <tr> <td>USINAGE</td> <td>± 0.1</td> <td>± 0.004"</td> </tr> <tr> <td>TOLERIE</td> <td>± 0.5</td> <td>± 0.020"</td> </tr> <tr> <td>SOUDAGE</td> <td>± 0.5</td> <td>± 0.020"</td> </tr> </tbody> </table>		TOLERANCE		INCH	USINAGE	± 0.1	± 0.004"	TOLERIE	± 0.5	± 0.020"	SOUDAGE	± 0.5	± 0.020"	SIPROMAC	
TOLERANCE		INCH																	
USINAGE	± 0.1	± 0.004"																	
TOLERIE	± 0.5	± 0.020"																	
SOUDAGE	± 0.5	± 0.020"																	
PART	SEAL BAR PRE-ASSEMBLY			ST-GERMAIN DE GRANTHAM, QUEBEC CANADA															
ITEM:	CNC:			M-I	QT. LISTE														
MAT:	DWG BY APP.	A.P.	DATE 98-02-10	NO. 004-0355															

004B4113

ITEM	PART #	DESCRIPTION	QT.
1	106-0010	VALVE 2WAY N.C. 24VAC 1/4" NPT(SMC)	1
2	102-0330	ELBOW 1/4" NPT X 3/8" HOSE QUICK	1
3	100-0065	STREET ELBOW 1/4" NPT SS	1
4	102-0361	Y BRANCH 1/4" MNPT X 3/8" T. QUICK	1

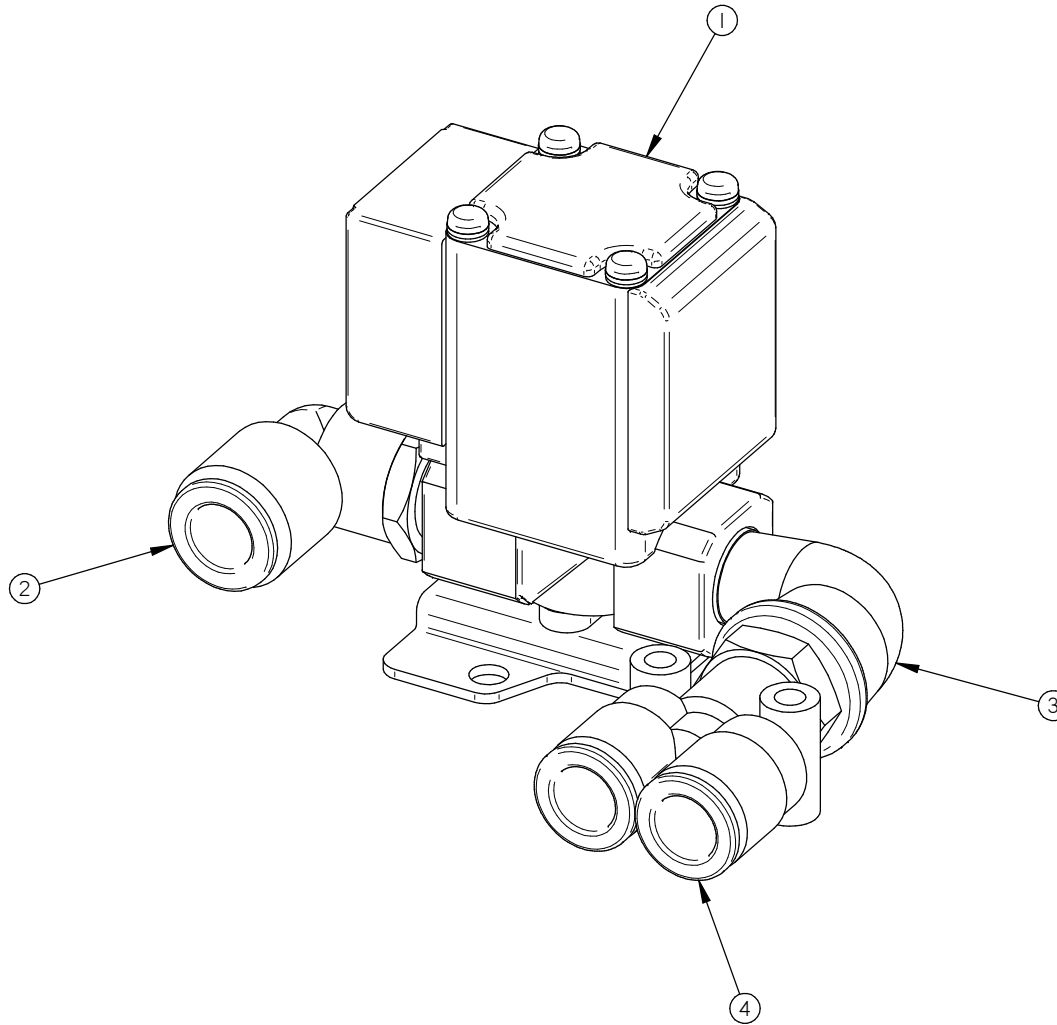

-OPTION - GAS

MACHINE		VACUUM		DEPT. TOL.	METRIC	INCH	SIPROMAC ST-GERMAIN DE GRANTHAM QUEBEC CANADA
PART		GAS VALVE ASSEMBLY (OPTION)		USINAGE	± 0.1	± 0.004"	
ITEM				TOLERIE	± 0.5	± 0.020"	
MAT.				SOUDEAGE	± 0.5	± 0.020"	N.T.S.
APP. BY		CNC		DEPT.		M	QTY.
DATE		DWG BY	SBU	DATE	14-05-27	NO. 004B4113	

A	VALVE UPDATE	14-05-27	SBU
LET.	MODIFICATION	DATE	INT.

004A4152

ITEM	PART #	DESCRIPTION	QT.
1	004A4140	AIR REGULATOR SUPPORT	1
2	100-0060	STREET ELBOW 1/8" NPT SS	1
3	100-0065	STREET ELBOW 1/4" NPT SS	3
4	100-0225	CLOSE NIPPLE 1/4" NPT SS	1
5	100-0463	TEE 1/4" NPT S/S	1
6	102-0330	ELBOW 1/4" NPT X 3/8" HOSE QUICK	2
7	102-0361	Y BRANCH 1/4" MNPT X 3/8" T. QUICK	1
8	102-0410	MALE CONN. 1/4" MNPT X 3/8" T. QUICK	1
9	106-00701	VALVE 3WAY 24V 1/4" NPT	1
10	114-0147	PRESSURE REGUL. 0-60 PSI 1/4" NPT	1
11	114-0245	PRESSURE GAUGE 60 PSI 1/8" NPT	1

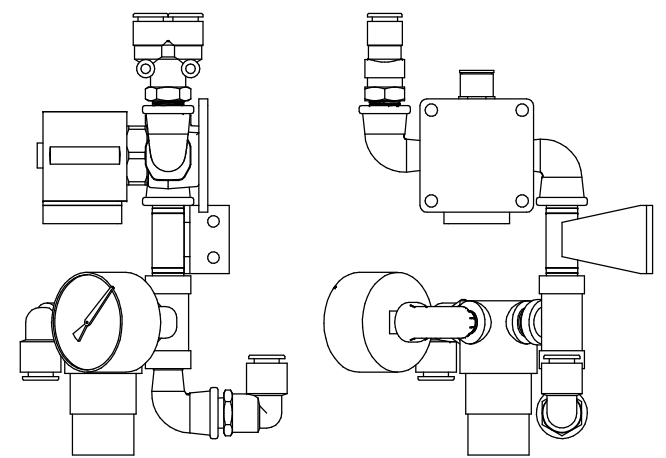
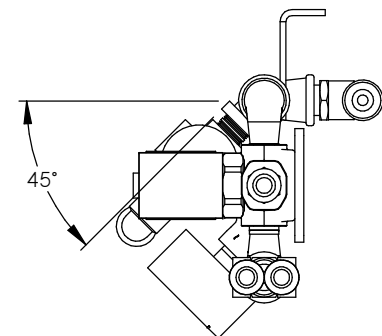
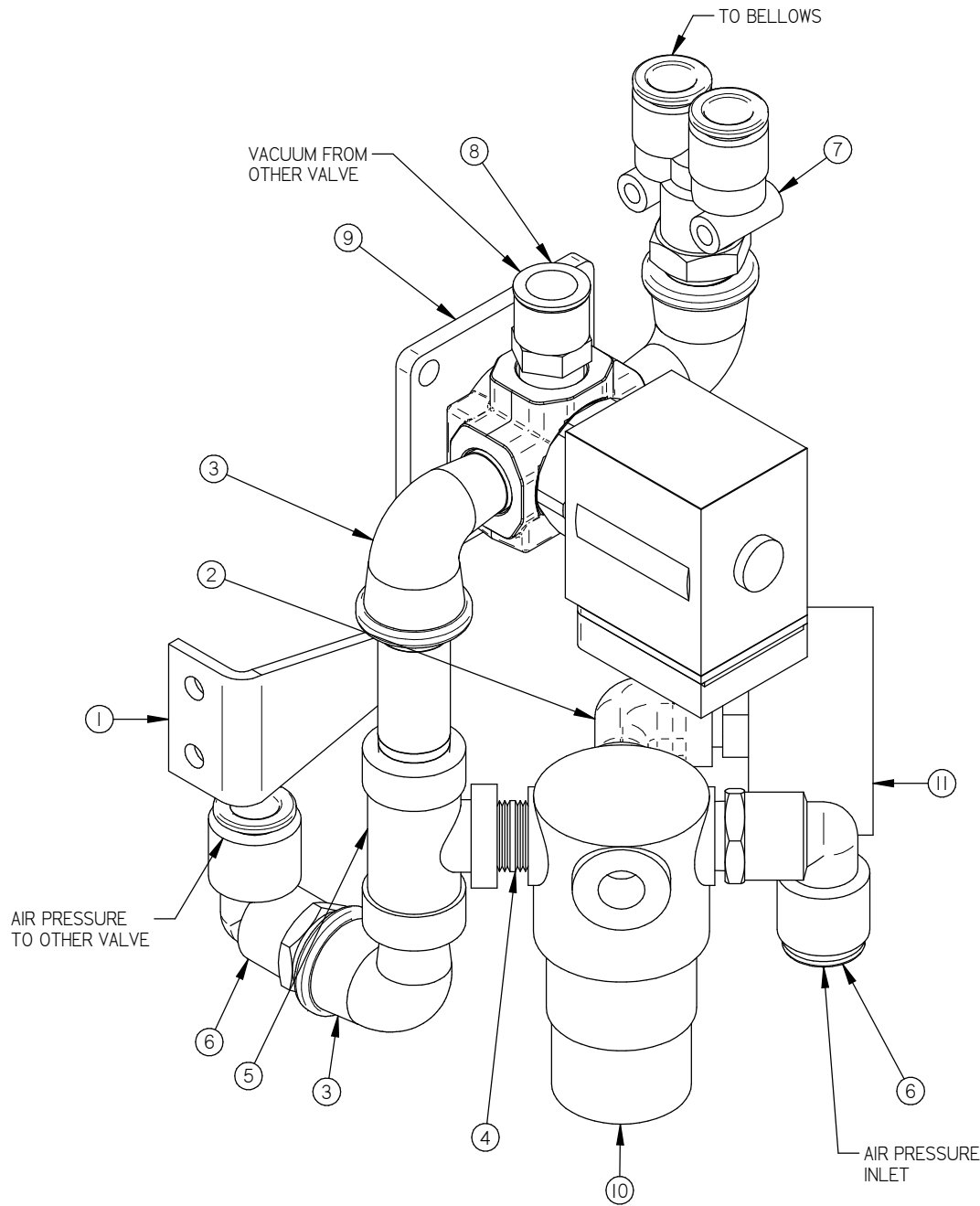

LET.	MODIFICATION	DATE	INT.
------	--------------	------	------

MACHINE	420A		DEPT. TOL.	METRIC	INCH	SIPROMAC ST-GERMAIN DE GRANTHAM QUEBEC CANADA
PART	AIR REGULATOR VALVE ASSY		USINAGE	± 0.1	± 0.004"	
			TOLERIE	± 0.5	± 0.020"	
			SOUDEAGE	± 0.5	± 0.020"	N.T.S.
ITEM	CNC	DEPT.	M	QTY.	1	
MAT.	DWG BY SBU	DATE 14-01-27	NO.	004A4152		
	APP. BY	DATE				

004B4105

ITEM	PART #	DESCRIPTION	QT.
1	001B6779	VALVE SUPPORT BRACKET	1
2	051-0144	SCREW #10-24 N.C 1/2" PAN PHIL. S/S	4
3	051-0572	NUT #10-24 NYLON LOCK S/S	4
4	100-0225	CLOSE NIPPLE 1/4" NPT SS	1
5	100-0463	TEE 1/4" NPT S/S	1
6	102-0330	ELBOW 1/4" NPT X 3/8" HOSE QUICK	3
7	102-0361	Y BRANCH 1/4" MNPT X 3/8" T. QUICK	1
8	106-00701	VALVE 3WAY 24V 1/4"NPT	1

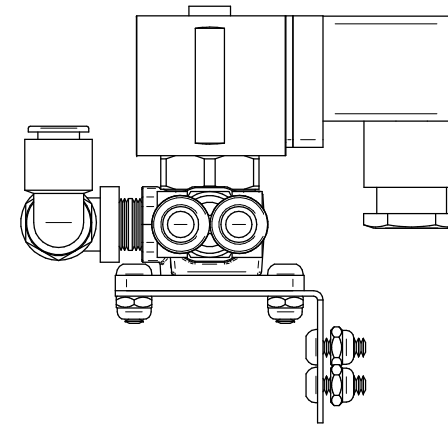
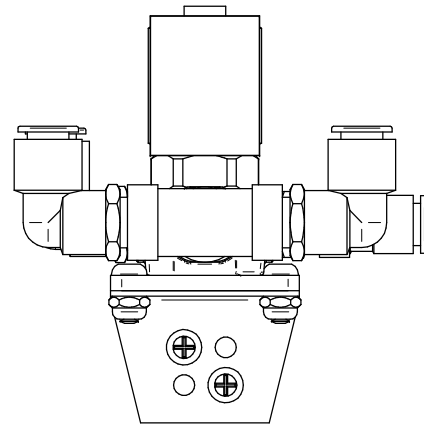
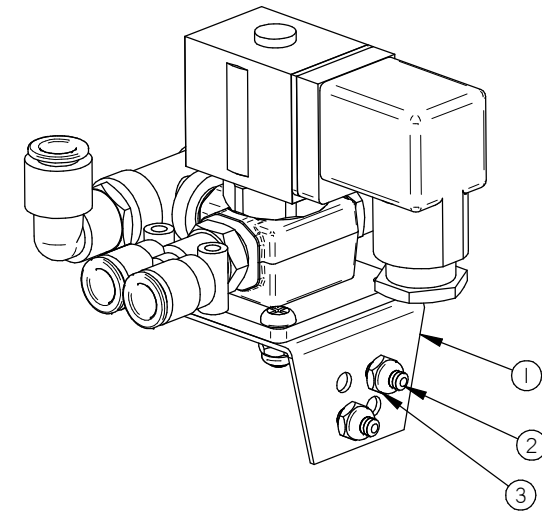
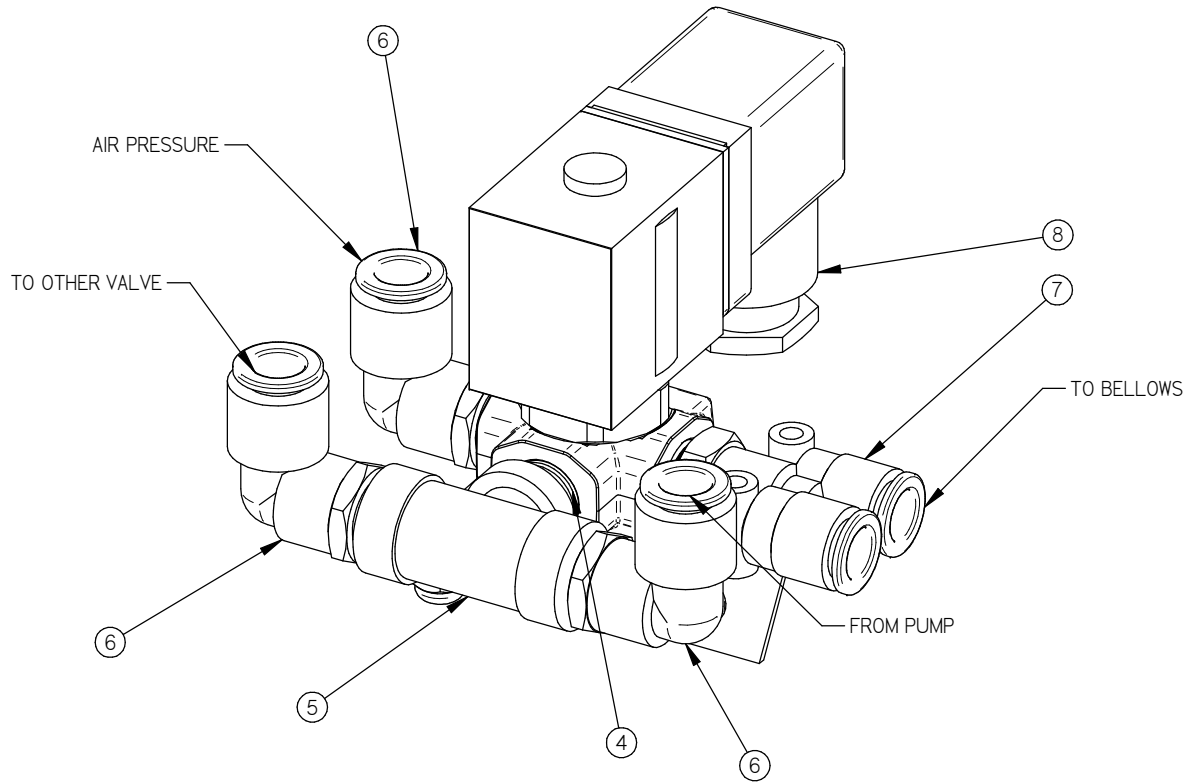

-OPTION - AIR REGULATOR

A	UPDATE VALVE	14-05-27	SBU
LET.	MODIFICATION	DATE	INT.

MACHINE		VACUUM		DEPT. TOL.	METRIC	INCH	SIPROMAC ST-GERMAIN DE GRANTHAM QUEBEC CANADA
PART		BELLOWS VALVE ASSY (OPT AIR REG)		USINAGE	± 0.1	± 0.004"	
ITEM		CNC		TOLERIE	± 0.5	± 0.020"	
MAT.		APP. BY		SOUDEGE	± 0.5	± 0.020"	N.T.S.
		DWG BY SBU		DATE 14-05-27		DEPT.	M
		DATE				QTY.	1
						004B4105	

004A4111

ITEM	PART #	DESCRIPTION	QT.
1	100-0555	RED.BUSH.1-1/2" x 1-1/4" NPT S/S	1
2	100-0245	CLOSE NIPPLE 1/4"npt. S/S	1
3	107-0090	BALL VALVE 1-1/4"NPT	1
4	114-2030	VACUUM MUFFLER 1-1/4"NPT	1

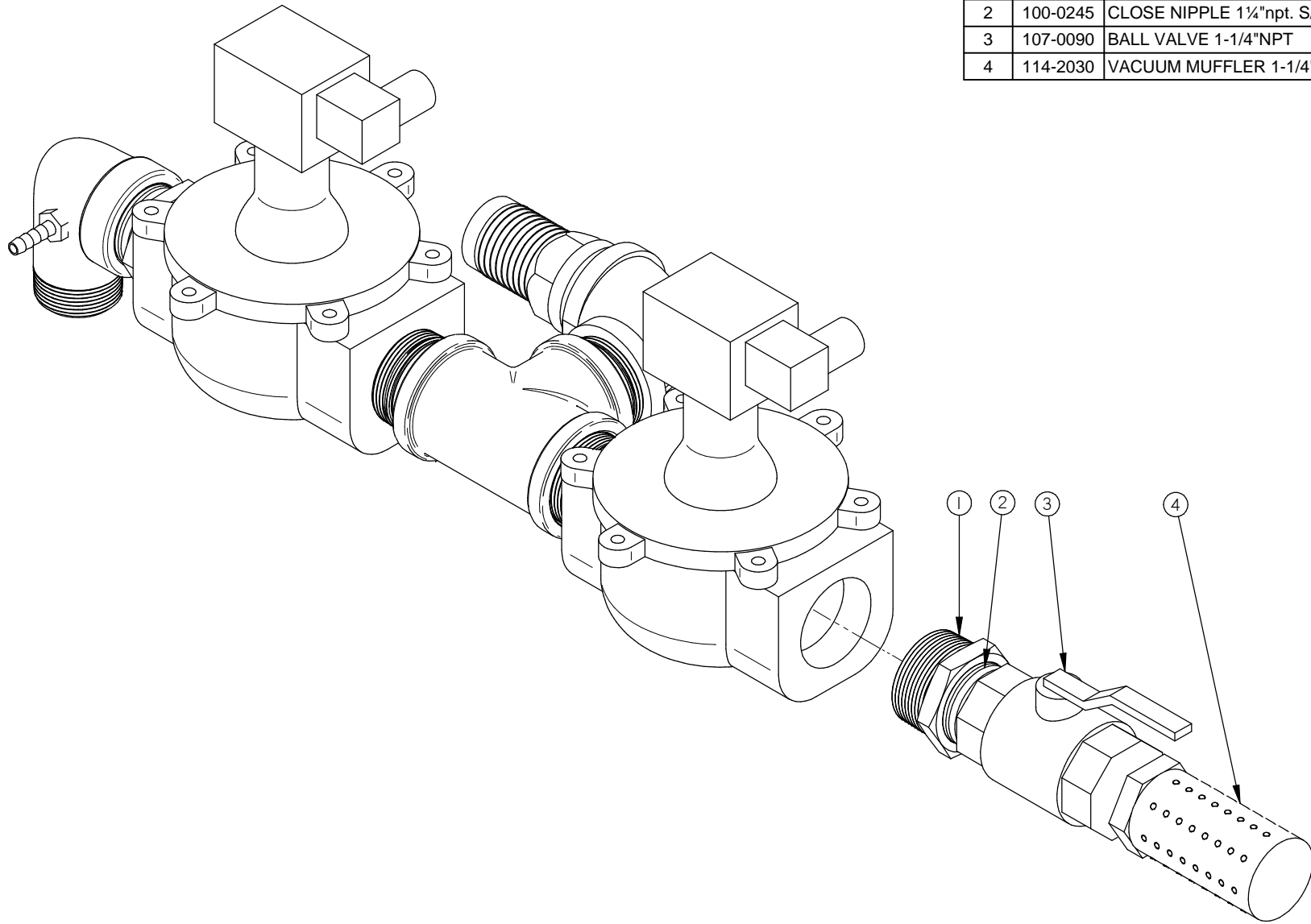

-OPTION - SOFT AIR + MUFFLER 40M³ @ 100M³

LET.	MODIFICATION	DATE	INT.
------	--------------	------	------

MACHINE		VACUUM		DEPT. TOL.	METRIC	INCH	SIPROMAC ST-GERMAIN DE GRANTHAM QUEBEC CANADA
PART		VACUUM/ATMOSPHERE VALVE (OPT SOFT AIR+MUFFLER)		USINAGE	± 0.1	± 0.004"	
ITEM		CNC		TOLERIE	± 0.5	± 0.020"	
MAT.		APP. BY		SOUDEGE		± 0.5	± 0.020"
		DWG BY SBU		DATE 13-09-19		N.T.S.	
		APP. BY		DATE		DEPT. M QTY. 1	
						004A4111	

004A4110

ITEM	PART #	DESCRIPTION	QT.
1	100-0555	RED.BUSH.1-1/2" x 1-1/4" NPT S/S	1
2	100-0245	CLOSE NIPPLE 1 1/4"npt. S/S	1
3	107-0090	BALL VALVE 1-1/4"NPT	1

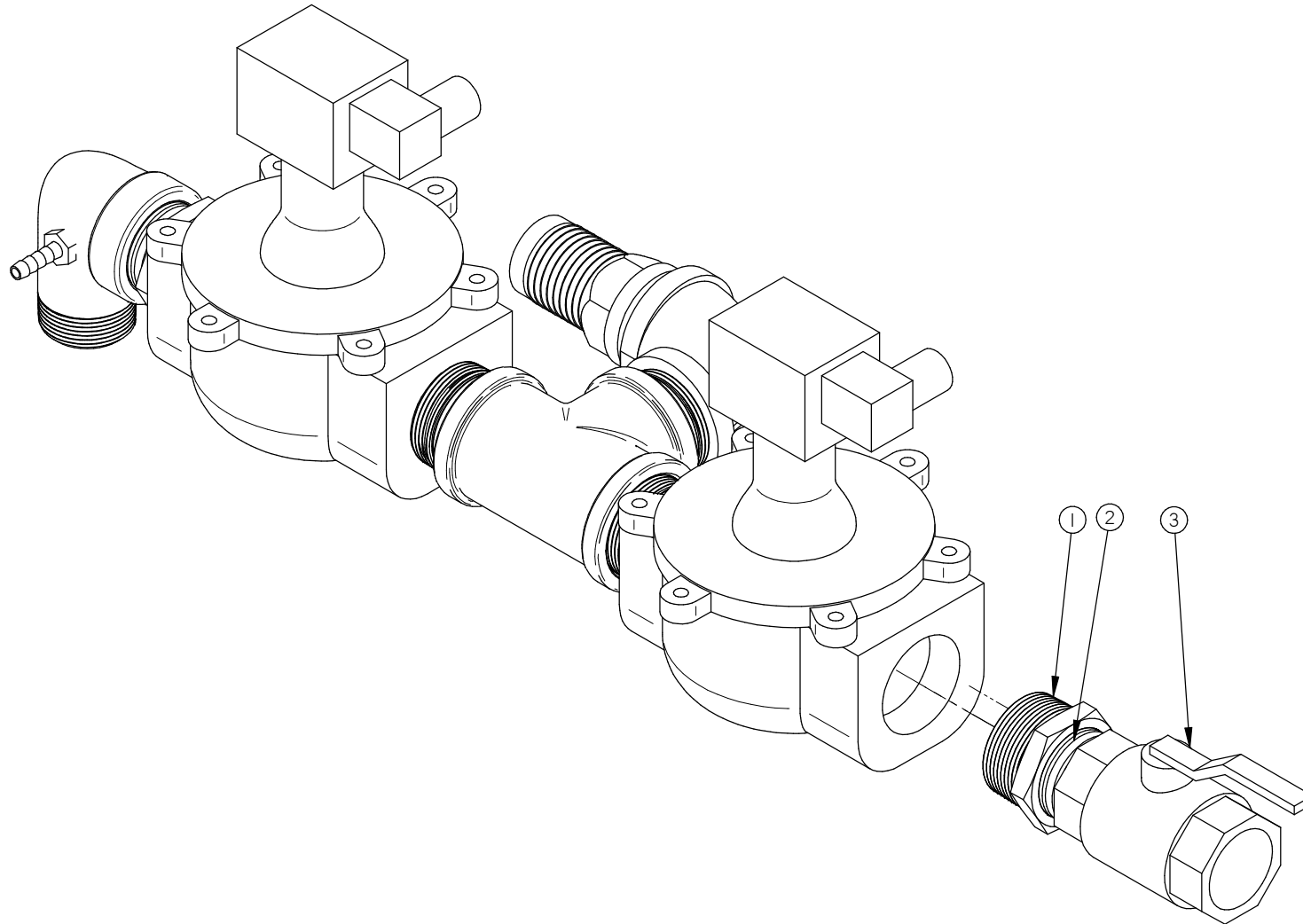

-OPTION - SOFT AIR 40M³ @ 100M³

MACHINE		VACUUM		DEPT. TOL.	METRIC	INCH	SIPROMAC ST-GERMAIN DE GRANTHAM QUEBEC CANADA
PART		VACUUM/ATMOSPHERE VALVE (OPT SOFT AIR)		USINAGE	± 0.1	± 0.004"	
ITEM		CNC		TOLERIE	± 0.5	± 0.020"	
MAT.		APP. BY		DATE		N.T.S.	
LET.		MODIFICATION		DATE		INT.	
		DWG BY SBU		DATE 13-09-19		NO. 004A4110	
		APP. BY		DATE		DEPT. M QTY. 1	

LET.	MODIFICATION	DATE	INT.
------	--------------	------	------

004A4109

ITEM	PART #	DESCRIPTION	QT.
1	100-0555	RED.BUSH.1-1/2" x 1-1/4" NPT S/S	1
2	114-2030	VACUUM MUFFLER 1-1/4"NPT	1

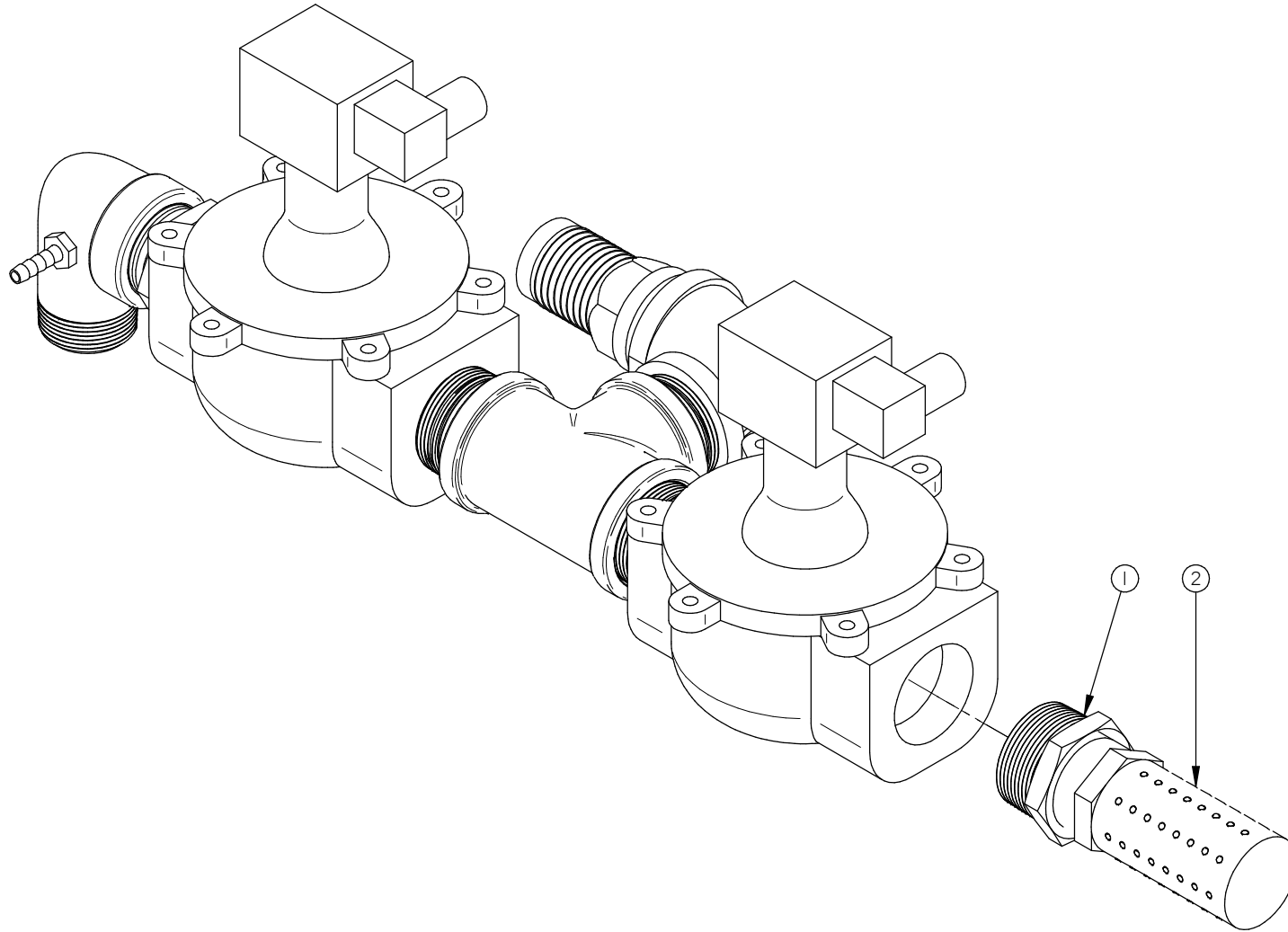

-OPTION - MUFFLER 40M³ @ 100M³

MACHINE		VACUUM		DEPT. TOL.	METRIC	INCH	SIPROMAC ST-GERMAIN DE GRANTHAM QUEBEC CANADA
PART		VACUUM/ATMOSPHERE VALVE (OPT MUFFLER)		USINAGE	± 0.1	± 0.004"	
ITEM		CNC		TOLERIE	± 0.5	± 0.020"	
MAT.		APP. BY		DATE		NO.	1
LET.		MODIFICATION		DATE		INT.	004A4109

LET.	MODIFICATION	DATE	INT.
------	--------------	------	------

005B1370

ITEM	PART #	DESCRIPTION	QT.
1	001B6292	SLANTED FILLER PLATE	1
2	001B6293	SLANTED FILLER PLATE ADJ. STOPPER	2
3	005-0187	ASS. BARRURE	4
4	051-01845	BOLT 1/4"-20 x 1/2"CAP HEX SKT.S/S	4
5	057-0004	THMB SCREW KNOB 1/4"	4
6	179-0014	RUBBER 1/4"x3/8"x1/16"U SHAPED	2

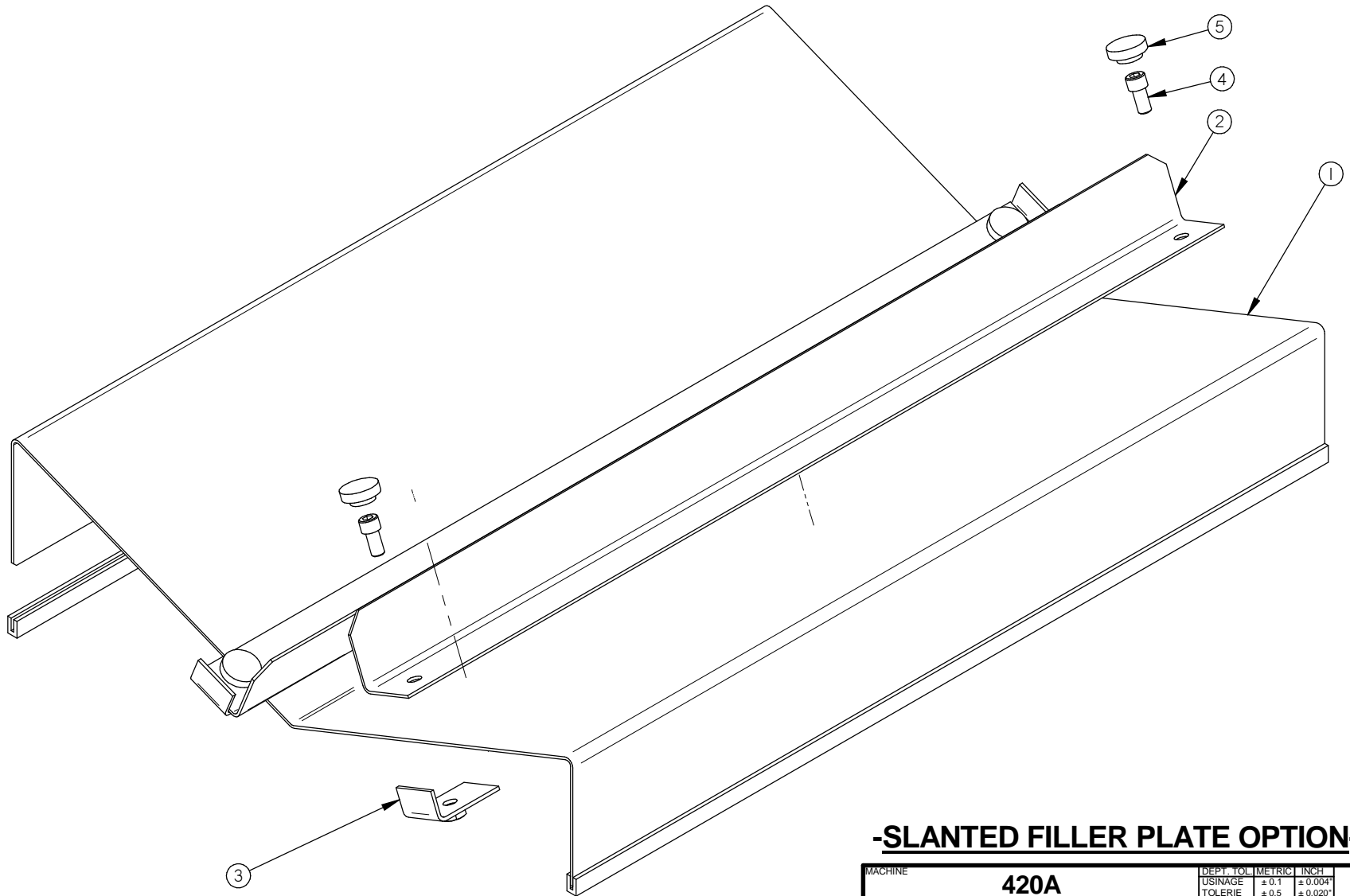

-SLANTED FILLER PLATE OPTION-

MACHINE	420A		DEPT. TOL. METRIC	INCH	SIPROMAC ST-GERMAIN DE GRANTHAM QUEBEC CANADA
PART	SLANTED FILLER PLATE ASS'Y		USINAGE ± 0.1 ± 0.004"	TOLERIE ± 0.5 ± 0.020"	
ITEM			SOUDAGE ± 0.5 ± 0.020"	N.T.S.	
MAT.	CNC	DEPT.	M-I	QTY.	2
	DWG BY SBU	DATE 14-01-27	NO. 005B1370		
	APP. BY	DATE			

A	LENGTHEN BY 60MM	14-01-27	SBU
LET.	MODIFICATION	DATE	INT.

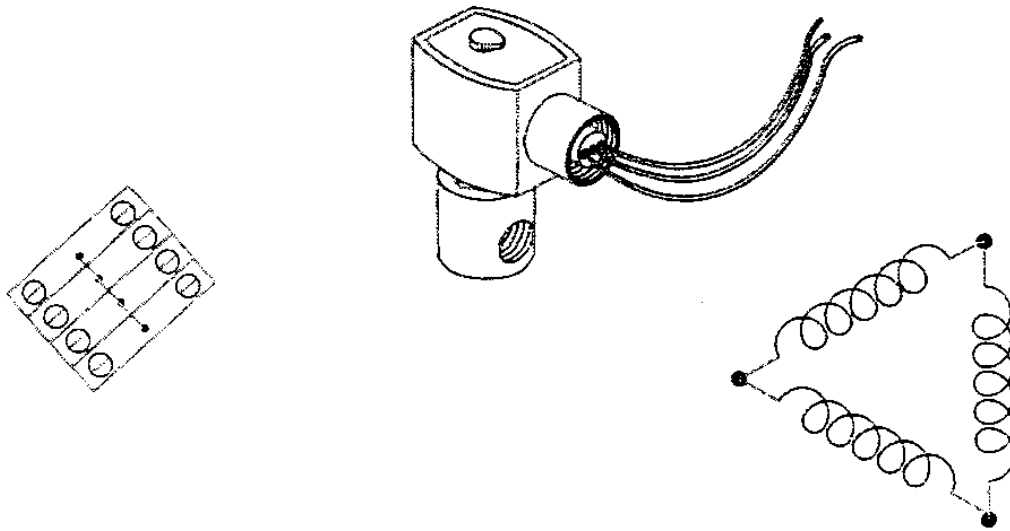

ELECTRICAL DRAWING

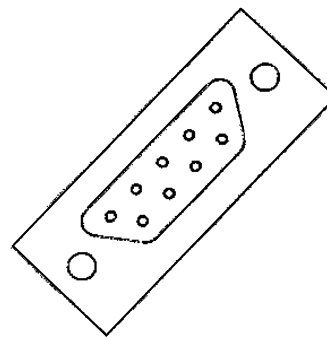
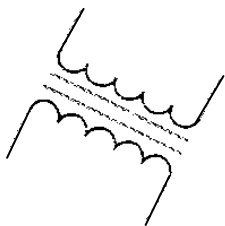

TRANSF.CONT.(yel 25)

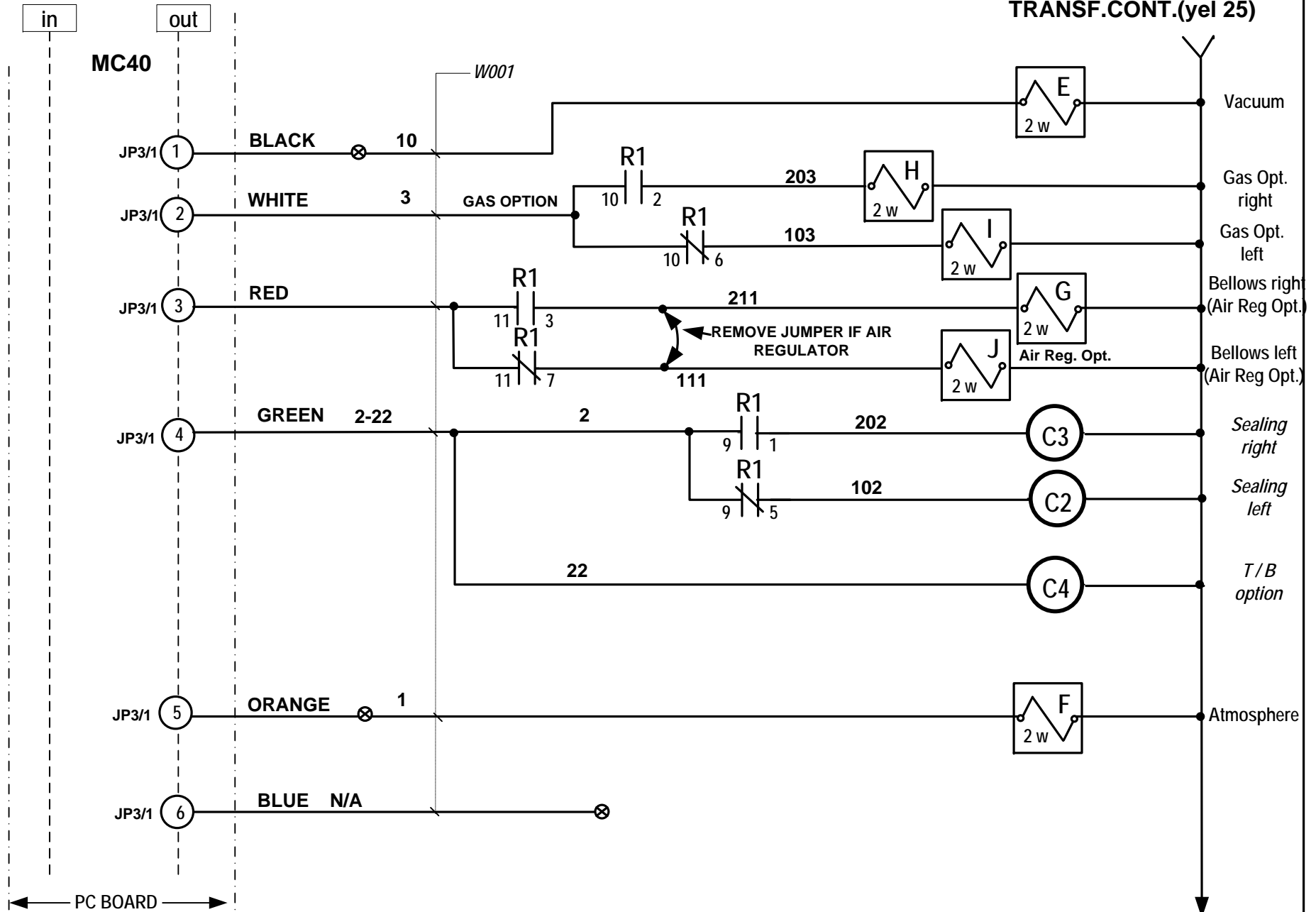

RC filters must be connected on each AC coil (not shown on diagram)

category	VACUUM PACK	model	420A	volt.	ALL				SIPROMAC St-Germain de Grantham QUEBEC, CANADA
system	Control			circuit	control	year	month	day	
usual fonctions	MC-40					05	03	03	
options						concept	draw	app	
						PP	PP	DL	
						006-0637			PAGE 1 de 3
									3

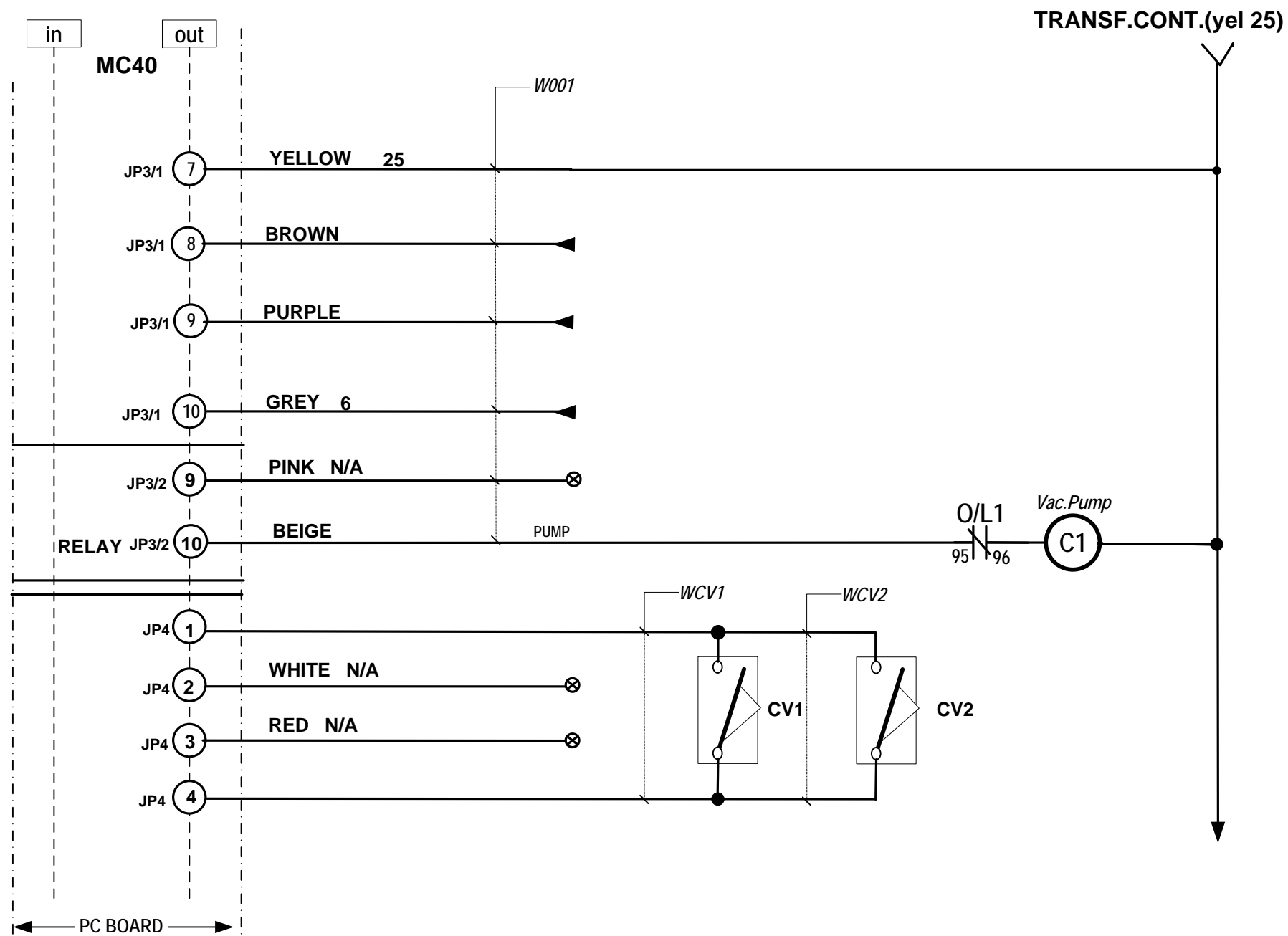

RC filters must be connected on each AC coil (not shown on diagram)

category	VACUUM PACK		model	420A		volt.	ALL				SIPROMAC St-Germain de Grantham QUEBEC ,CANADA		
system	Control					circuit	control			year		month	day
usual fonctions	MC-40					concept	05	03	03				
options						draw	PP	PP	DL	006-0637			
										app	DL	PAGE	2 de 3
													3

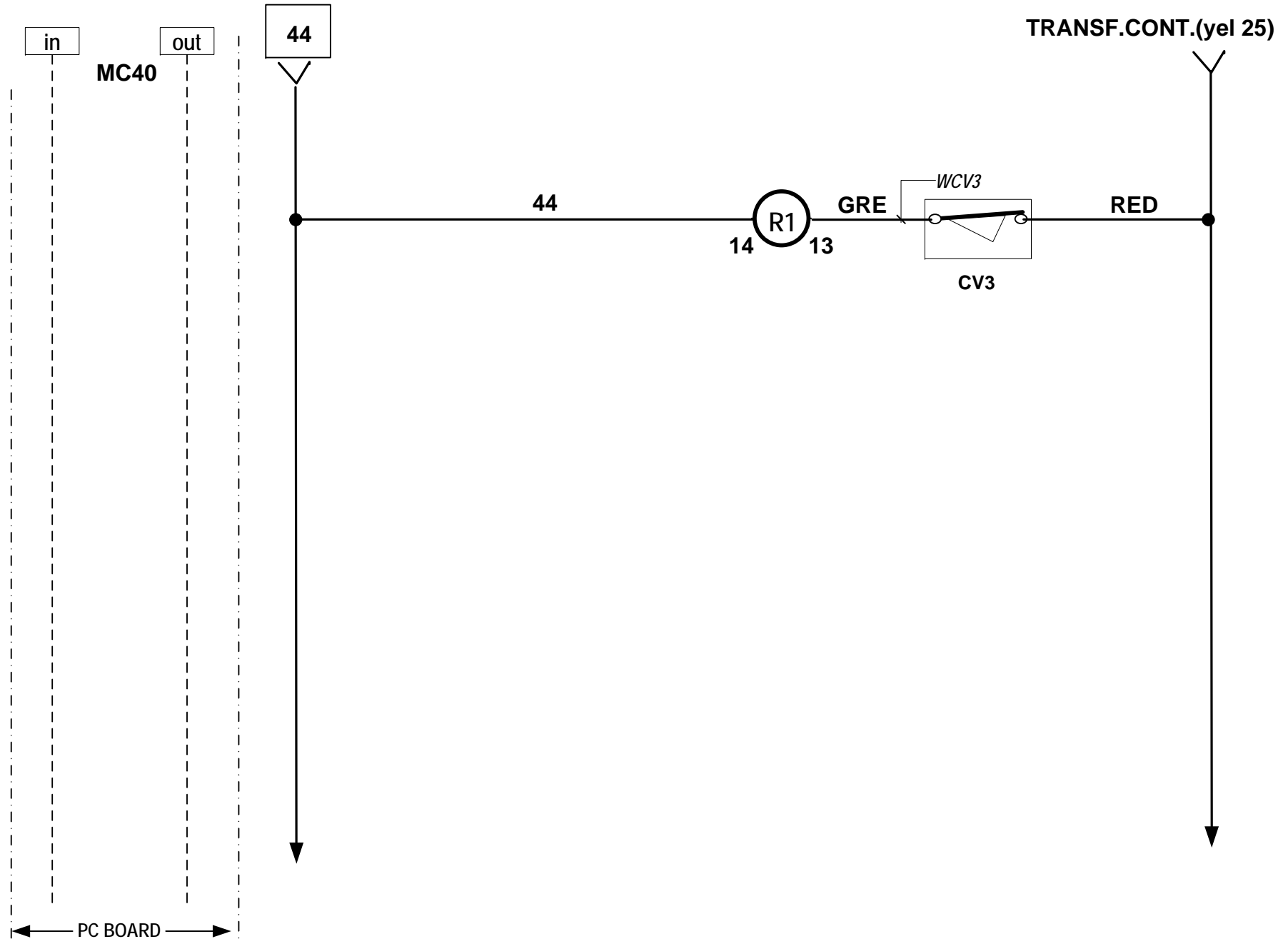

RC filters must be connected on each AC coil (not shown on diagram)

category	VACUUM PACK	model	420A	volt.	ALL				SIPROMAC St-Germain de Grantham QUEBEC, CANADA
system	Control			circuit	control	year	month	day	
usual functions	MC-40			concept	PP	draw	PP	app	DL
options							006-0637		PAGE 3 de 3

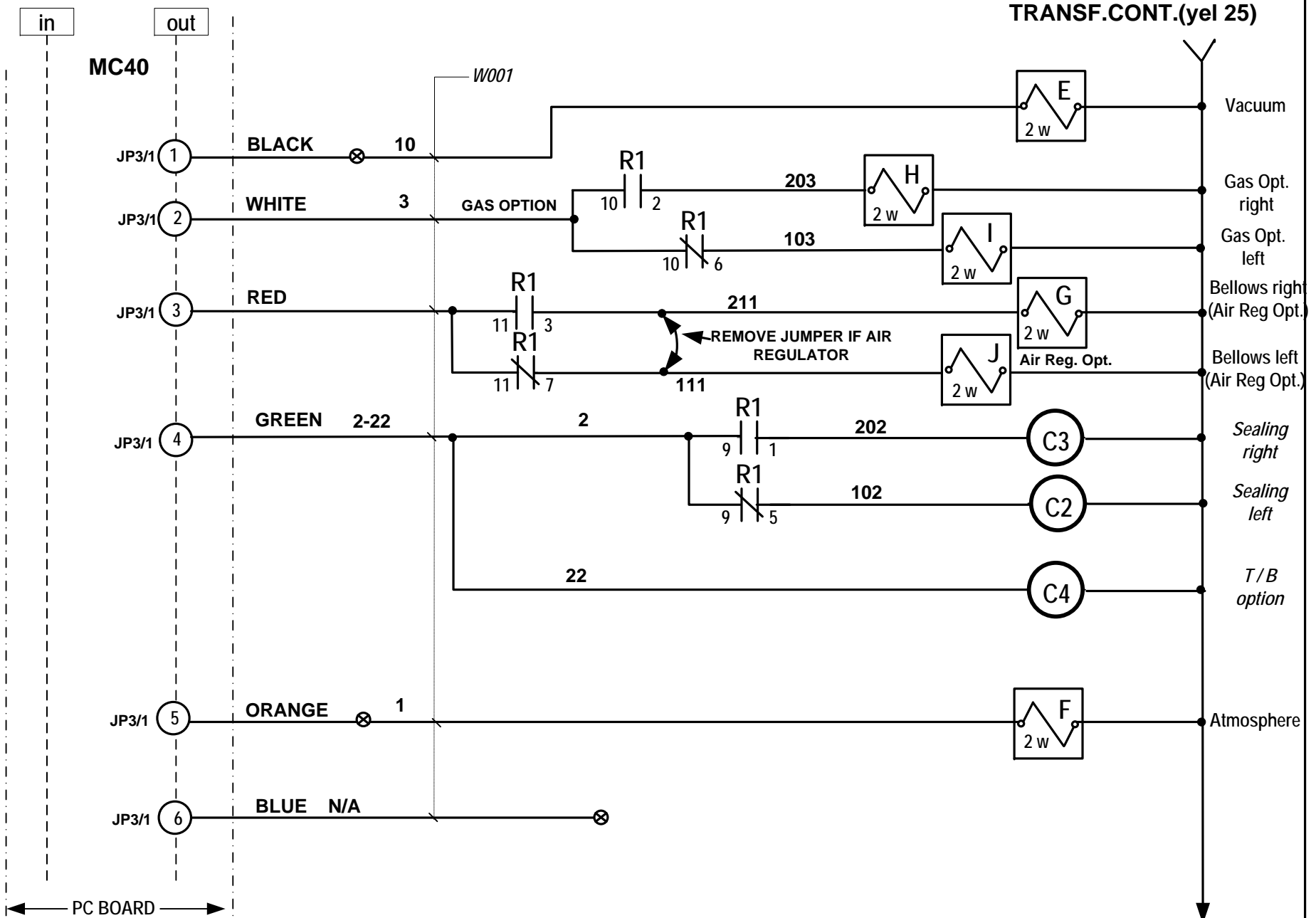

 *RC filters must be connected on each AC coil (not shown on diagram)*

category	VACUUM PACK	model	420A	volt.	ALL					
system	Control			circuit	control	year	month	day	block	SIPROMAC St-Germain de Grantham QUEBEC, CANADA
usual fonctions	MC-40					05	03	03		
options						concept	draw	app		006-0637
						PP	PP	DL		PAGE 1 de 3

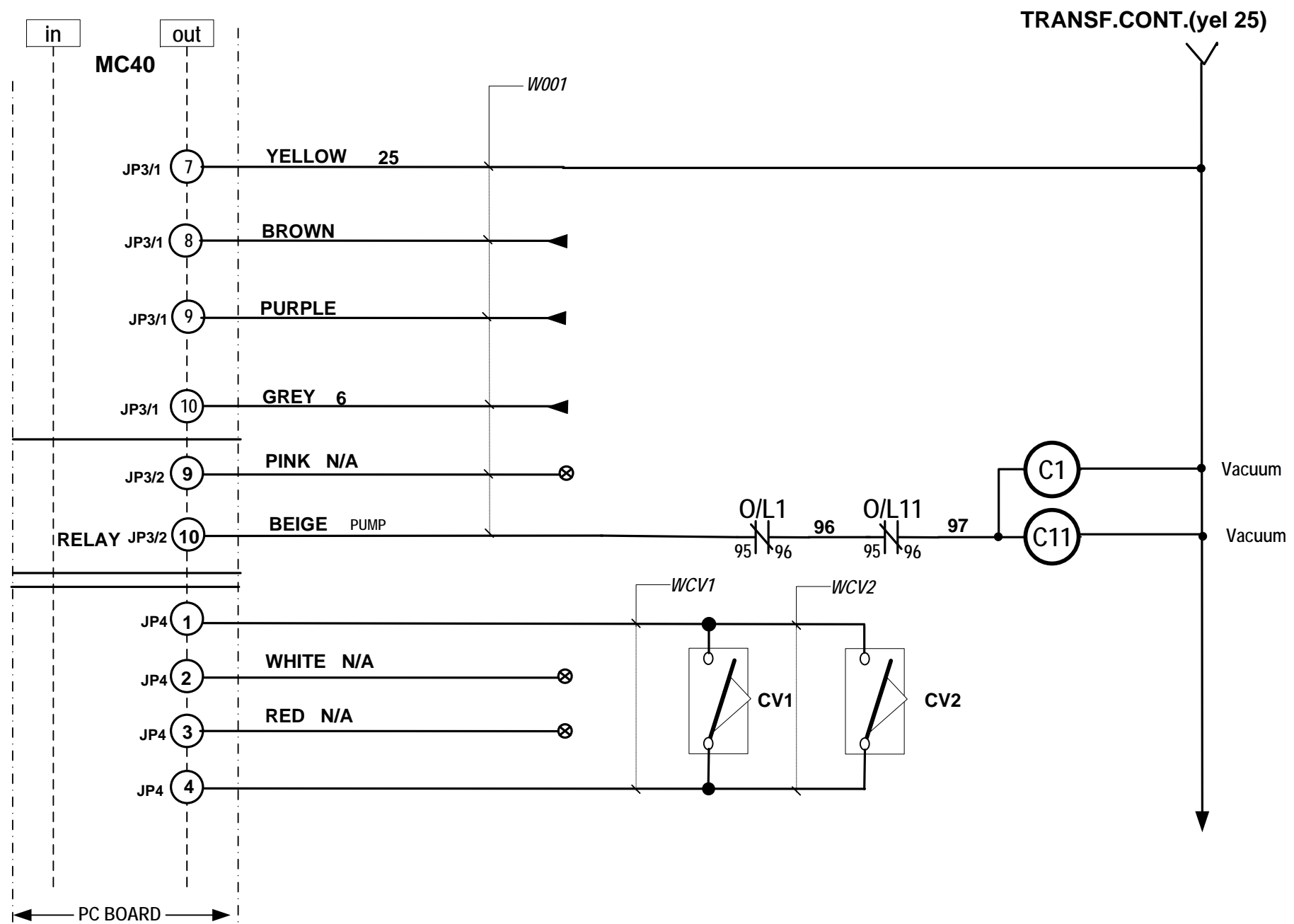

RC filters must be connected on each AC coil (not shown on diagram)

category	VACUUM PACK	model	420A	volt.	ALL	SIPROMAC			
system	Control			circuit	control	year	month	day	block
usual fonctions	MC-40					05	03	03	St-Germain de Grantham QUEBEC ,CANADA
options						concept	draw	app	006-0637
						PP	PP	DL	PAGE 2 de 3
									3

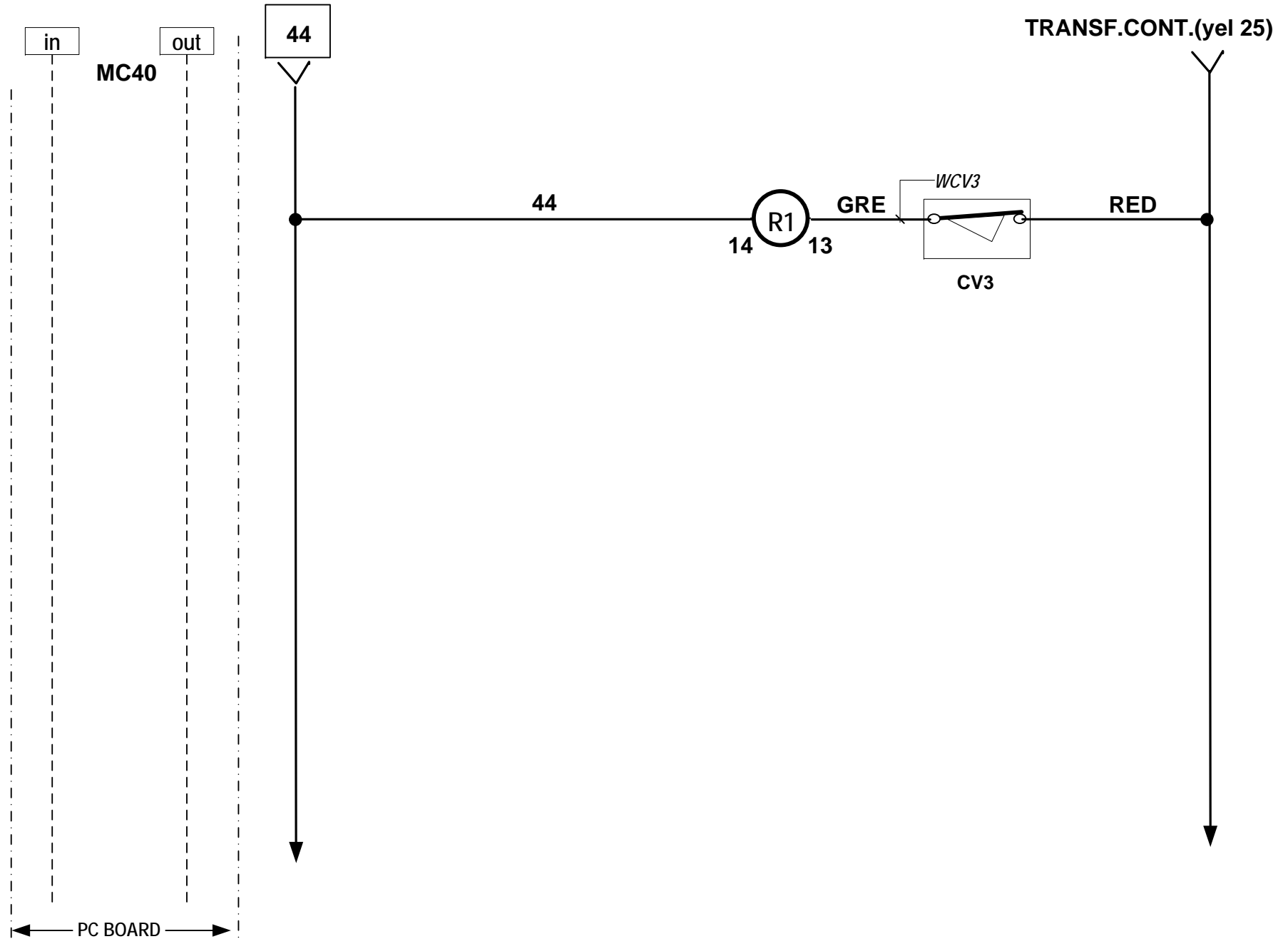

RC filters must be connected on each AC coil (not shown on diagram)

category	VACUUM PACK	model	420A	volt.	ALL				SIPROMAC St-Germain de Grantham QUEBEC, CANADA
system	Control			circuit	control	year	month	day	
usual functions	MC-40			concept	PP	draw	PP	app	DL
options				006-0637			PAGE	3 de 3	3

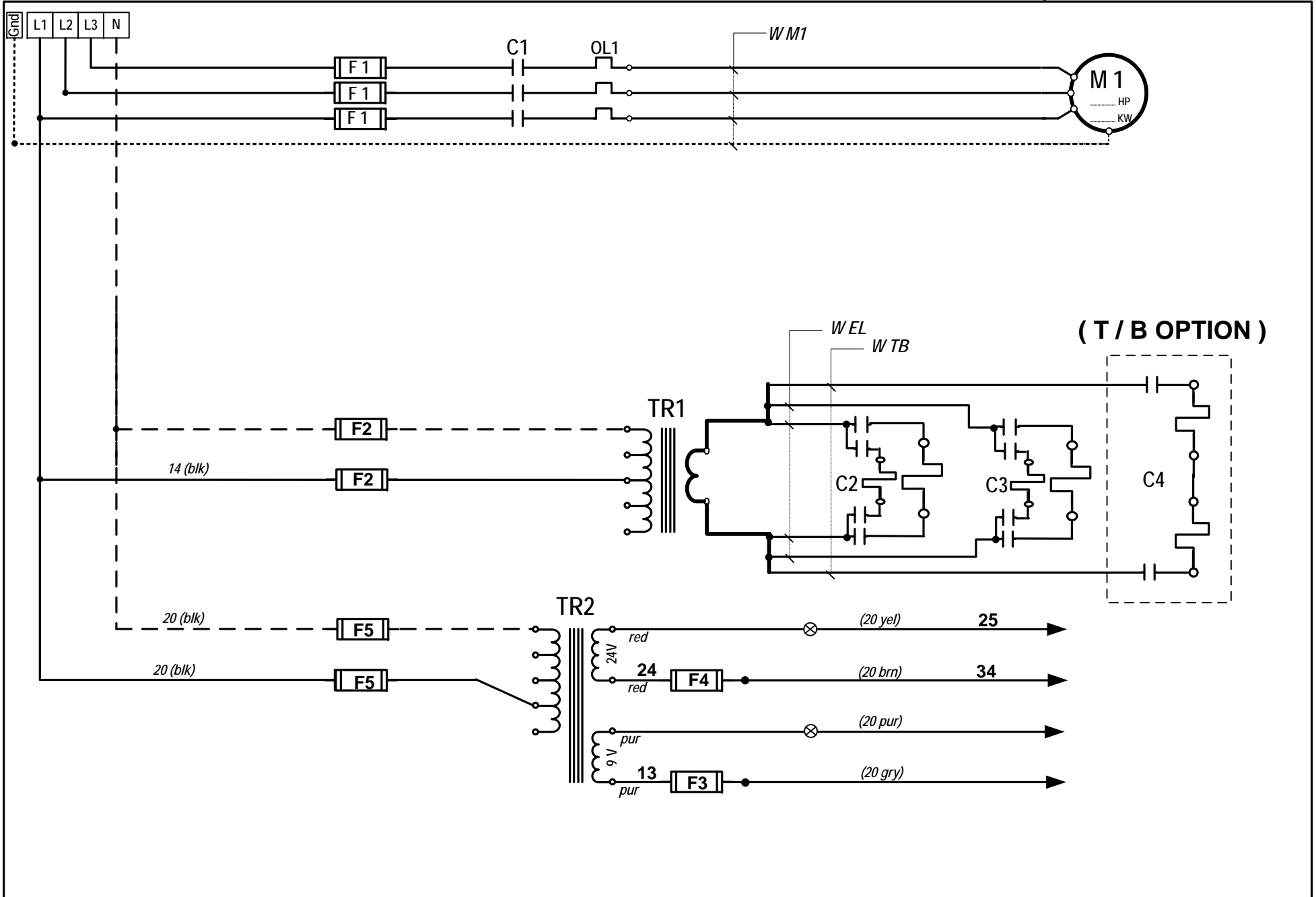

category	VACUUM PACK	model	420A	voit.	3Ph 60Hz				SIPROMAC St-Germain de Grantham QUEBEC, CANADA	
system	POWER			circuit	year	month	day	block		
usual	MC-40			power	05	01	18		006-0630 PAGE 1 de 1	
fonctions				concept	draw	app				
options					PP	PP	DL			

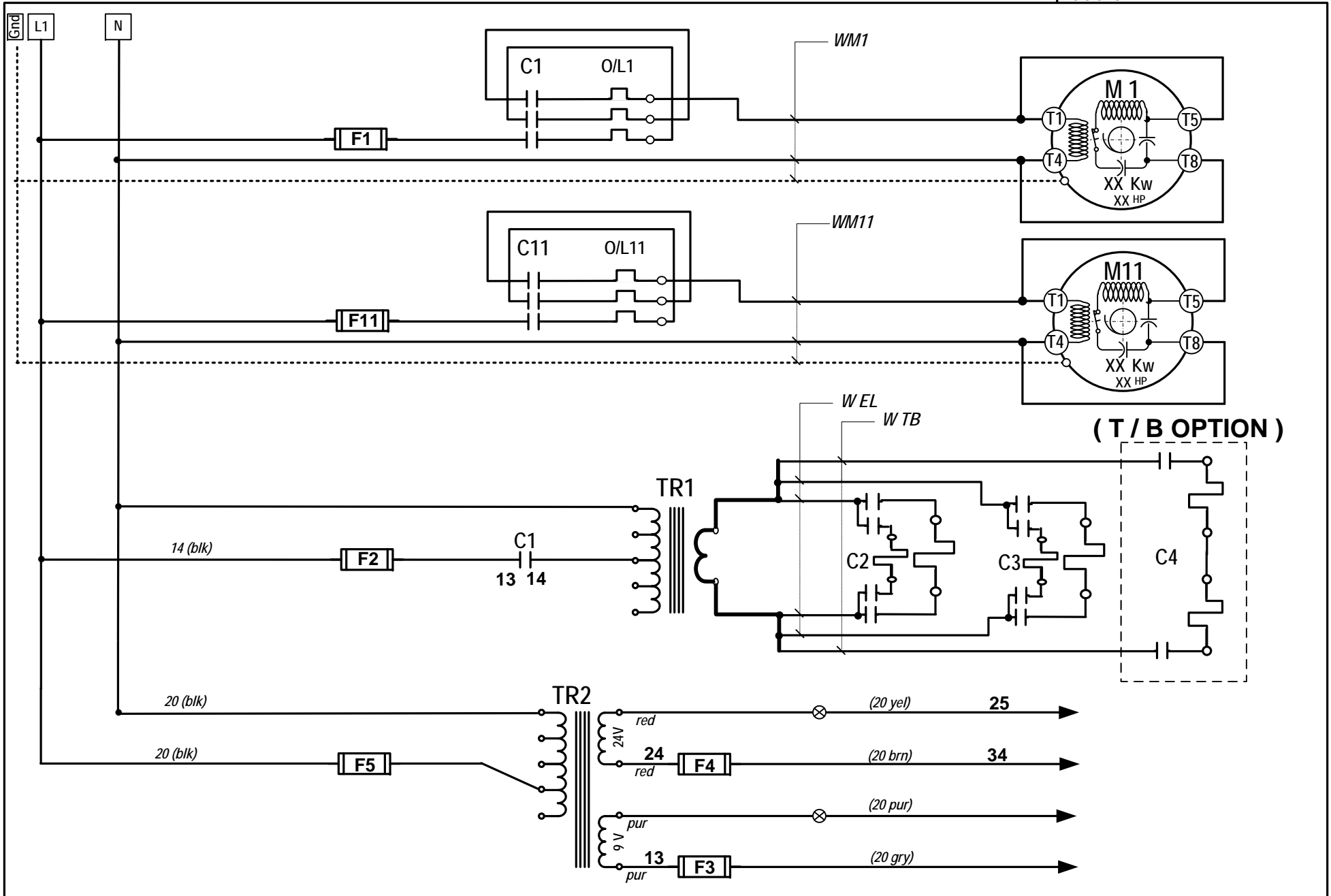

category	VACUUM PACK	model	420A	volt.	120v 1Ph 60Hz				SIPROMAC St-Germain de Grantham QUEBEC ,CANADA
system	POWER			circuit	power	year	month	day	
usual fonctions	MC-40					10	08	10	
options	2 KB0020 pumps					concept	draw	app	
						XX	XX	XX	006-0721 PAGE 1 de 1

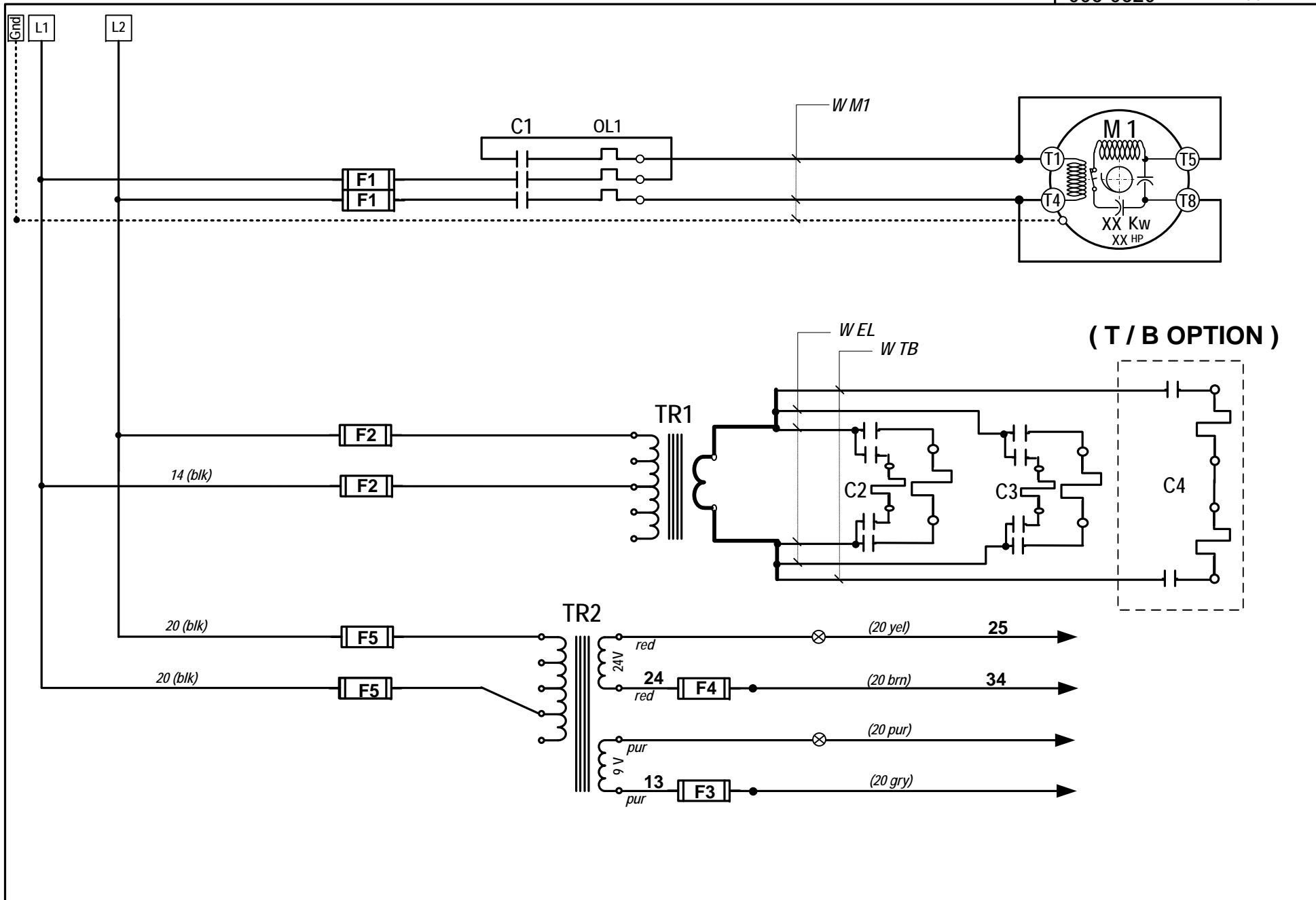

category	VACUUM PACK	model	420A	volt.	1Ph 60Hz				SIPROMAC	
system	POWER			circuit	power	year	month	day	block	St-Germain de Grantham
usual fonctions	MC-40					05	01	18		QUEBEC ,CANADA
options					concept	draw	app		006-0620	PAGE 1 de 1
					PP	PP	DL			

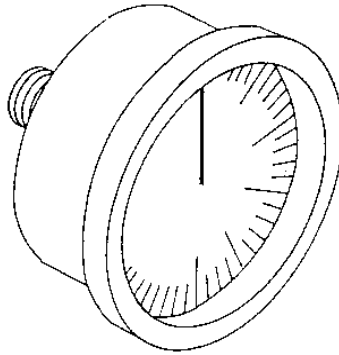

PNEUMATIC DRAWING

