

# **VACUUM PACKAGING MACHINE**

## **MODELS 350 & 350D**

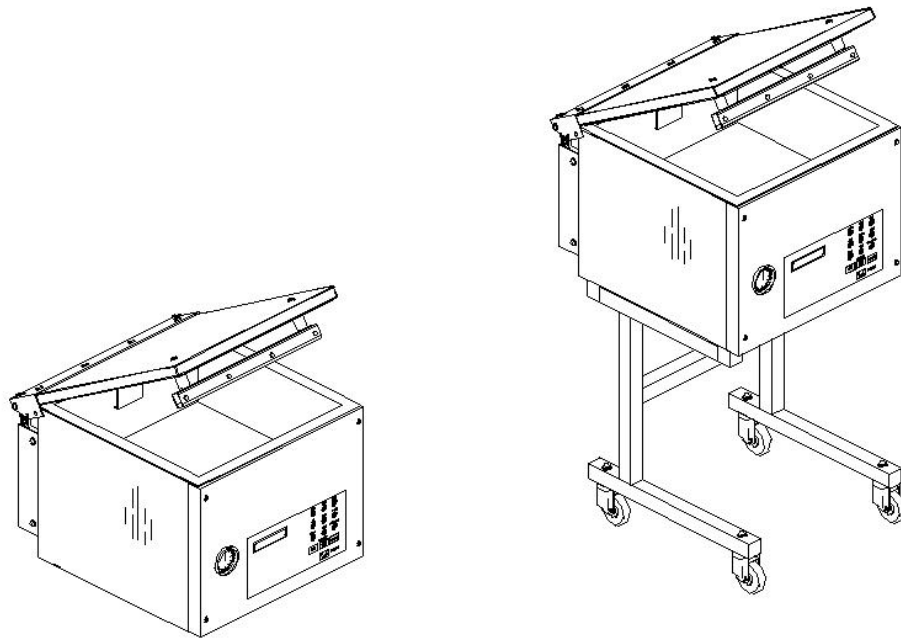

### **OWNERS MANUAL** **(MANUEL D'UTILISATION)** **(MANUAL DE UTILIZACIÓN)**



# IMPORTANT SAFETY INSTRUCTIONS

## SAVE THESE INSTRUCTIONS



This symbol points out important safety instructions which, if not followed, could endanger the personal safety and/or property of yourself and others. Read and follow all instructions in this manual before attempting to operate your machine. Failure to comply with these instructions may result in personal injury.

### General Operation

- Read, understand, and follow all instructions in the manual and on the machine before starting. Keep this manual in a safe place for further and regular reference and for ordering replacement parts.
- Only allow responsible individuals familiar with the instructions to operate the machine. Be sure to know controls and how to stop the machine quickly.
- Never put your hands near moving parts.
- Only allow qualified individuals for the maintenance of your machine.
- Remove all obstacles, which may interfere with the machine functions.
- Clear the work area such as electrical wires, buckets, knives etc.
- Be sure that everyone else is clear of your work area before operating the machine.
- Do not sit nor stand on the machine.
- Always turn off the machine after your work is done. Never leave a running machine unattended.
- Always disconnect and wait till the machine has cooled before attempting any maintenance.
- Do not wear loose fitting clothes or jewelry as they may get caught in moving parts of the machine.
- Always wear security shoes, to prevent injury caused by moving the machine or objects falling from the machine.
- Never exceed the time limit to seal, which is recommended by the manufacturer. This is to avoid any damage that may be caused to the sealing bars and to eliminate the risk of fire in the machine. Thus avoiding corporal burns.
- Never touch the sealing bars after they have been used, this will avoid corporal burns. Wait a few minutes to let the machine cool down before touching.
- Always make sure that the sealing bars are well installed in their "Guide Blocks" before starting a cycle.
- Never incline the machine more than 30 degrees, it may tip over and hurt someone seriously.
- Work only in daylight or good artificial light.
- Do not operate any appliance with a damaged cord or plug, or after the appliance malfunctions or is dropped or damaged in any manner. Return appliance to the nearest authorized service facility for examination, repair, or electrical or mechanical adjustment.

**Do not operate the machine while under the influence of alcohol or drugs!**

## Service

- Use proper containers when draining the oil. Do not use food or beverage containers that may mislead someone into drinking from them. Properly dispose of the containers, or store in a safe place immediately following the draining of the oil.
- Prior to disposal, determine the proper method to dispose of waste from your local office of Environmental Protection Agency. Recycling centers are established to properly dispose of materials in an environmentally safe fashion.

**Do not pour oil or other fluids into the ground, down a drain or into a body of water.**



### Warning-Your responsibility:

**This machine should only be operated by personal who can read, understand and respect warnings and instructions regarding this machine in the owners manual. Save these instructions for future reference.**

## INSTALLATION NOTICE FOR MODELS:

250, 300, 350, 350D, 380 & 450T

### IN ORDER TO RESPECT NSF REGULATIONS:

The table on which the machine has to be installed, should be of open frame type, to avoid dirt accumulation, and to allow easy cleaning under the machine.

# VACUUM PACKAGING MACHINE

## MODEL 350, 350D

(MC-40)

### GENERAL TABLE OF CONTENTS

I	OPERATION INSTRUCTIONS
II	MECHANICAL
	A- 350: front view assembly drawing.
	B- 350: rear view assembly drawing
	C- 350D: front view assembly drawing
	D- 350D: rear view assembly drawing
	E- 350 & 350D: front panel assembly
	F- Seal bar assembly drawings (twin seal)
	G- Seal bar assembly drawings (electrical bag cut option)
	H- 350: cover assembly drawing
	I- 350D: cover assembly drawing
	J- 350 & 350D: upper seal bar assembly drawing
	K- 350: gas injection kit installation drawing
	L- 350D: gas injection kit installation drawing
III	ELECTRICAL
	A- Electrical drawings
IV	PNEUMATIC
	A- Pneumatic drawing

# VACUUM PACKAGING MACHINES-OPERATION INSTRUCTIONS

## TABLE OF CONTENTS

1. Setting up the machine
2. Electrical connection
3. Operation
  - 3.1 Working principles
  - 3.2 Special packaging
    - 3.2.1 Gas flushing
    - 3.2.2 Electrical bag cut (optional)
  - 3.3 Vacuum packaging operation
    - 3.3.1 Basics
    - 3.3.2 Functions menu
      - 3.3.2.1 Create a program
      - 3.3.2.2 Delete a program
      - 3.3.2.3 Select operating mode
    - 3.3.3 Programs menu
      - 3.3.3.1 Program identification
      - 3.3.3.2 Vacuum time setting (sensor disabled)
      - 3.3.3.3 Vacuum level setting (sensor enabled)
      - 3.3.3.4 Vacuum plus time setting (sensor enabled)
      - 3.3.3.5 Gas time setting (sensor disabled)
      - 3.3.3.6 Gas flush level setting (sensor enabled)
      - 3.3.3.7 Sealing time setting
    - 3.3.4 Vacuum cycle execution
    - 3.3.5 System monitor
  - 3.4 Daily cleaning
4. Trouble shooting
  - 4.1 Failure during a packaging cycle
  - 4.2 Insufficient vacuum
    - 4.2.1 Leakage in the bag
    - 4.2.2 No leakage in the bag
    - 4.2.3 Insufficient vacuum in the chamber
  - 4.3 Faulty seal
    - 4.3.1 Insufficient seal
    - 4.3.2 No seal
    - 4.3.3 Permanent sealing current
    - 4.3.4 Seal does not stick
  - 4.4 Fault in the valves
  - 4.5 Control board failure
5. Regular maintenance

2010-08-30

# VACUUM PACKAGING MACHINES

## **1. SETTING UP THE MACHINE:**

Before choosing the site for the machine, please consider that you will also need room for packaged and non-packaged products apart from the space needed for the machine itself.

Keep in mind that the machine must not be set up upon uneven ground. Especially with mobile models, the weight of the pump might then cause warping of the machine. Then the lid will not fit correctly.

Before starting to work, check the oil view glass on the pump, if there is a sufficient quantity of oil in the pump. Never use oil other than recommended by the producer. Never exceed maximum quantity of oil indicated, when adding or changing oil. Verify weekly.

Normal ambient temperature for the vacuum pump is between 10 to 70°C. For temperature below 10°C; it is recommended to use synthetic oil. Please consult factory and pump manufacturer manual for more information or when ambient temperature are outside normal limits.

## **2. ELECTRICAL CONNECTION:**

Electrical connections must be made by qualified personnel. This person must make sure that the electrical entries correspond to the proper voltage and amperage of the machine. **GROUNDING INSTRUCTIONS:** This appliance must be grounded. In the event of malfunction or breakdown, grounding provides a path of least resistance for electric current to reduce the risk of electric shock. This appliance is equipped with a cord having an equipment-grounding conductor and a grounding plug. The plug must be plugged into an appropriate outlet that is properly installed and grounded in accordance with all local codes and ordinances.

**DANGER** Improper connection of the equipment-grounding conductor can result in a risk of electric shock. The conductor with insulation having an outer surface that is green with or without yellow stripes is the equipment-grounding conductor. If repair or replacement of the cord or plug is necessary, do not connect the equipment-grounding conductor to a live terminal. Check with a qualified electrician or serviceman if the grounding instructions are not completely understood, or if in doubt as to whether the appliance is properly grounded. Do not modify the plug provided with the appliance if it will not fit the outlet; have a proper outlet installed by a qualified electrician.

All vacuum machines are supplied with an electrical schematic drawing. An important step in connecting the machine is to make sure that the pump turns in its correct rotation.



The pump should not rotate more than 3 to 4 seconds in the wrong rotation or it may cause serious damage. The proper rotation is indicated by an arrow on the pump motor.

### **3. OPERATION:**

#### **3.1 Working principles:**

A vacuum packaging cycle is made of 3 stages. First the vacuum is made, the air is completely taken out of the chamber and from bag containing the product. (See figure 1). Then it is possible to inject neutral gas from the nozzles, if the product is delicate. Finally, a mechanism pushes the sealing bar to the rubber support to seal the bag.

To obtain nice packages, the products and the bags have to be of proportional sizes. The bag's opening should never exceed 50 cm(2") past the seal bars. The product should be centered in height in relation to the seal bar by adjusting the spacers provided.

To obtain a good seal, make sure that no residue of fat is left between the bag's inner sides where sealing is done.

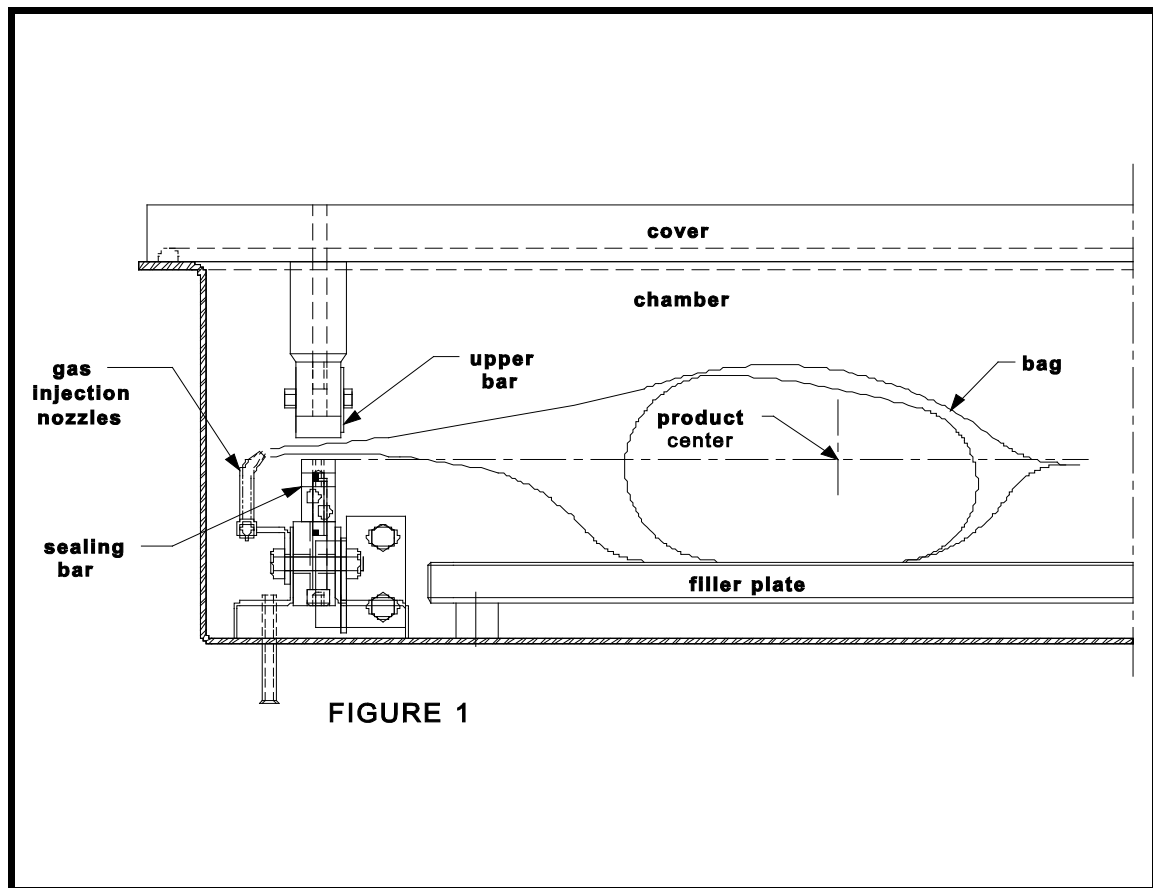

#### **3.2 Special packaging:**

### **3.2.1 Gas flushing (option):**

There is an atmospheric pressure of 1 kg/ sq. cm (14 lbs/sq. inch) upon products when fully evacuated. Products which can be damaged by high pressure must be packaged with a partial vacuum, or the pressure must be counterbalance by inflating the bag with gas (nitrogen or carbon dioxide) before sealing after evacuation.

For gas flushing, the bags are placed on the sealing bars, the open end placed over the gas nozzles mounted alongside the sealing bar. After evacuation, the vacuum valve closes and the gas valve opens. Gas time (sec.) can be set in the program menu.

The necessary gas tank and pressure valve mounted on tank is not supplied, The pressure of the gas regulator should be set at approximately 1/3 kg/sq. cm ( 5 lbs/sq.inch.). Each machine has an adaptor for gas connection when gas flush option is ordered.

### **3.2.2 Electrical bag cut (optional):**

This option is used to obtain a package that the excess bagtail is cut off close to the seal (cannot be used with top and bottom sealing).

## **3.3 Vacuum packaging operation:**

Note: Refer to the menus structure on page 13 and the keyboard detail on page 14.

### **3.3.1 Basics:**

Use key "POWER" to power ON / OFF the vacuum packaging machine. When the unit is energized, the identification of the last executed program is displayed on LCD screen. To disconnect, use the "POWER" key to turn off the machine , then remove plug from outlet. Do not unplug by pulling on cord. To unplug, grasp the plug, not the cord. Unplug from outlet when not in use and before servicing or cleaning.

Use the "ESC" key to change over from the programs menu to the functions menu and from the functions menu to the programs menu.

In functions menu, use key "SELECT" to select a function and key "ENTER" to accede and executed the selection.

In programs menu, use key "SELECT" to select a program and key "ENTER" to accede and modify the selection.

In programs submenu, use key "ENTER" to pass over the parameters and point to the following one; the parameters are blinking to point out the acquisition mode. A return to programs menu is performed automatically following the last parameter acquisition.

In program submenu, use key "ESC" to get back to the programs menu. Strike any key

to clear the error messages which may be displayed on LCD screen.

### **3.3.2 Functions menu:**

#### **3.3.2.1 Create a program:**

When executing the "create a program" function, the program submenu is acceded, starting with the identification. The initial identification "Pxx NO NAME" is given to the program and all parameters are established to zero; the program number is allocated automatically.

#### **3.3.2.2 Delete a program:**

When executing the "delete a program" function, the programs menu is acceded and the number of the first program in memory is blinking to point out the deletion mode. Use key "SELECT" to select a program and key "ENTER" to accede and confirm deletion of the selection. Use key "ESC" to unconfirm a deletion and to leave the function. When leaving the function, the number of the actual program on LCD screen cease to blink.

#### **3.3.2.3 Select operating mode:**

When executing the "select operating mode" function, which is available only for the automatic units, the actual selection is blinking to point out the acquisition mode. Use key "SELECT" to get through the operating modes, which are automatic, semi-automatic and manual; the validation of the selected operating mode is performed automatically. Use key "ESC" or "ENTER" to leave the function and get back to the program menu.

### **3.3.3 Programs menu:**

#### **3.3.3.1 Program identification:**

For a selected program, set the identification, using the numeric keyboard characters chart; press numeric key until the desired character is selected (4 times for the numeric value). Use key "ENTER" to validate the character and to validate the characters string at the end(the new characters string is blinking). In a middle of an acquisition, use key "ESC" to come backward and erase one or several characters.

**Example:** EXAMPLE 1    ➔    keys 2, 2, ENTER            ➔    E  
(9 characters)        ➔    keys 8, 8, 8, ENTER        ➔    X  
                         ➔    keys 1, ENTER              ➔    A  
                         ➔    keys 5, ENTER              ➔    M  
                         ➔    keys 6, ENTER              ➔    P  
                         ➔    keys 4, 4, 4, ENTER        ➔    L  
                         ➔    keys 2, 2, ENTER            ➔    E  
                         ➔    keys 9, 9, 9, ENTER        ➔    space  
                         ➔    keys 1, 1, 1, 1, ENTER    ➔    1  
                         key ENTER to validate the characters string

### **3.3.3.2 Vacuum time setting (sensor disabled):**

For a selected program set the vacuum time, in seconds; the validation is automatically performed following the second digit entry (the new vacuum time is blinking). In a middle of an acquisition, use key "ENTER" to validate the vacuum time and key "ESC" to come backward and start over with a new acquisition (the old vacuum time is blinking).

**Examples:** 1s → keys 0, 1 or 1, ENTER  
15s → keys 1, 5

### **3.3.3.3 Vacuum level setting (sensor enabled)**

For a selected program set the vacuum level, starting with the values; the decimal point is automatically inserted following the second digit entry and the validation is automatically performed following the third digit entry (the new vacuum level is blinking). The vacuum level is rounded off to the nearest half value. In the middle of an acquisition, use key "ENTER" to validate the vacuum level and key "ESC" to come backward and start over with a new acquisition (the old vacuum level is blinking). Set vacuum level to zero to bypass the pressure transducer and proceed only using the vacuum plus time.

**Examples:** 90.0% → keys 9, 0, 0 or 9, 0, ENTER or  
keys 9, 0, 1 or 9, 0, 2 or 9, 0, 3 or 9, 0, 4  
97.5% → keys 9, 7, 5 or  
keys 9, 7, 6 or 9, 0, 7 or 9, 0, 8 or 9, 0, 9  
0.0% → keys 0, 0, 0 or 0, ENTER

### **3.3.3.4 Vacuum plus time setting (sensor enabled)**

For a selected program set the vacuum plus time, in seconds; the validation is automatically performed following the second digit entry (the new vacuum plus time is blinking). In a middle of an acquisition, use key "ENTER" to validate the vacuum plus time and key "ESC" to come backward and start over with a new acquisition (the old vacuum plus time is blinking).

**Examples:** 1s → keys 0, 1 or 1, ENTER  
15s → keys 1, 5

### **3.3.3.5 Gas time setting (sensor disabled)**

For a selected program set the gas time setting following the same procedure as for the vacuum time. Keep in mind that increasing gas time decrease sealing pressure. Some vacuum must be kept inside to assure proper functioning.

### **3.3.3.6 Gas flush level setting: (sensor enabled)**

For a selected program set the gas flush level following the same procedure as for the vacuum level; the maximum gas flush level setting is 10% below the vacuum setting.

### **3.3.3.7 Sealing time setting:**

For a selected program set the sealing, starting with the seconds; the decimal point is automatically inserted following the first digit entry and the validation is automatically performed following the third digit entry (the new sealing time is blinking). The sealing time is truncated to the nearest half hundredth. In a middle of an acquisition, use key "ENTER" to validate the sealing time and key "ESC" to come backward and start over with a new acquisition (the old sealing time is blinking).

**Examples:** 4.50s → keys 4, 5, 0 or 4, 5, ENTER or  
keys 4, 5, 1 or 4, 5, 2 or 4, 5, 3 or 4, 5, 4  
2.35s → keys 2, 3, 5 or  
keys 2, 3, 6 or 2, 3, 7 or 2, 3, 8 or 2, 3, 9  
0.00s → keys 0, 0, 0 or 0, ENTER

### **3.3.4 Vacuum cycle execution:**

For the manual units and the automatic units set on manual, close the cover to initiate a vacuum cycle. For the automatic units set on semi-automatic or on automatic, use push button "STOP / START" to initiate or interrupt a vacuum cycle. A selected program can be initiated only in the programs menu, when no modifications are in progress, and the access to the other programs and functions is denied. During cycle execution the operation status is sequentially displayed on LCD screen, except for the parameters established to zero, which are not displayed:

- Vacuum time or vacuum % status during vacuum sequence,
- Gas time or gas % status during gas flush sequence,
- Sealing time status during sealing sequence,
- ATM message during atmosphere sequence.

During cycle execution, use key "1" to abort the vacuum sequence and execute the following sequence, which is gas flush or sealing, and key "ENTER" to accede and modify the program; the parameters become valid only for the following vacuum cycles.

### **3.3.5 System monitor:**

To accede the diagnostics menu, power up the vacuum packaging machine while keeping pushed in the "ESC"key. Use key "SELECT" to select the system monitor function and key "ENTER" to accede and visualize the monitored parameters. Use key "SELECT" to change over from the software revision, the amount of working hours done and the amount of complete cycles performed since first initialization.

## -MENUS STRUCTURE-

- **Functions menu:**

"F1 CREATE A PRGM"

"F2 DELETE A PRGM"

"F3 SELECT OPMODE" (automatic units only)

- **Programs menu:**

"Pxx NAME"

Program submenu:

"VACUUM: xx.x%" (10.0% - 99.5%)

"VACUUM PLUS: xxs" (0s - 99s)

"VACUUM: xx.xs" (10 – 199s) (sensor disabled in D8 menu)

"GAS FLUSH: xx.xs" (0 – 99s) (units with gas option) (sensor disabled in D8)

"GAS FLUSH: xx.x%" (0.0% - 10% below the vacuum level) (units with gas option)

"SEAL TIME: x.xxs" (0.00s - maximum unit allocated setting)

"Pxx NAME" (12 characters)

- **Diagnostics menu** (keys "ESC" & "POWER" for access):

"DIAGNOSTICS MENU" (access code required)

"D1 INPUTS TEST"

"D2 OUTPUTS TEST"

"D3 MODEL SELECT"

"D4 GAS OPTION"

"D5 SEALING TIME"

"D6 COOLING TIME"

"D7 OFFSET CALIB"

"D8 VACUUM SENSOR"

"D9 SIPROMAC PUB"

"D10 LOADING TIME" (automatic units only)

"D11 UNLOADNG TIME" (automatic units only)

"SYSTEM MONITOR" (no access code required)

"SOFTWARE: R x.xx"

"WORK HRS: xxxxx"

"CYCLES: xxxxxxxx"

# -KEYBOARD DETAILS-

## MC-40 CONTROLS

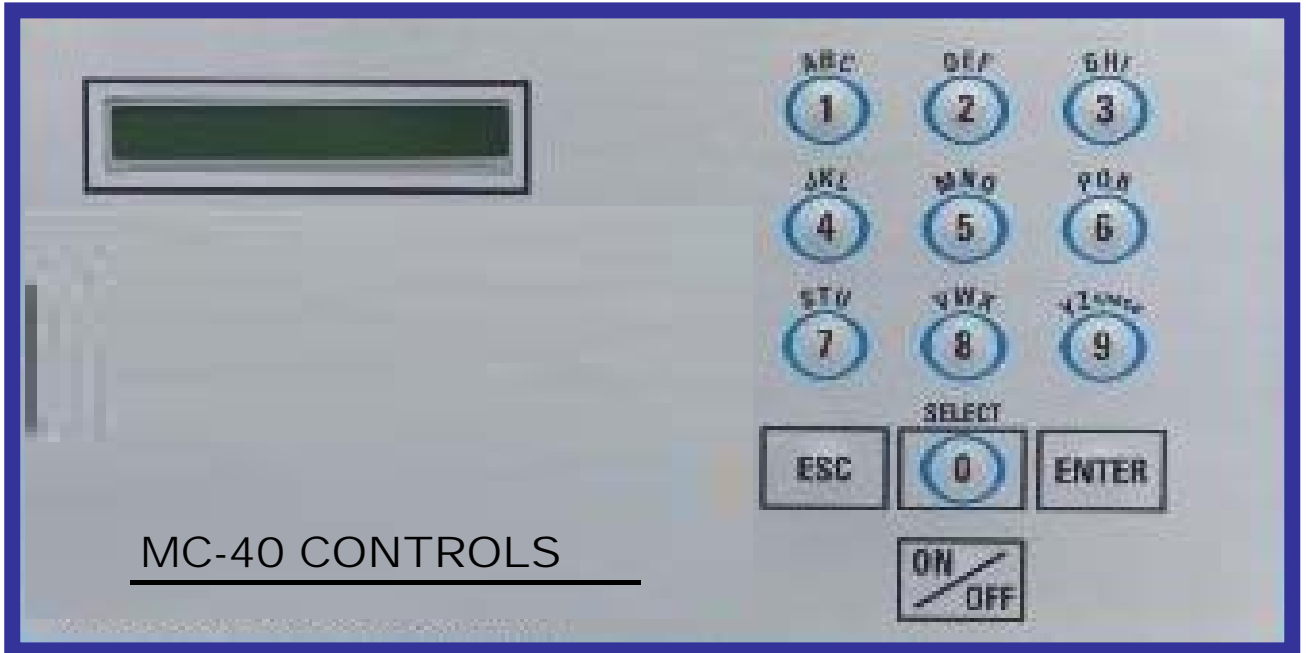



**WARNING: All electrical work described in this brochure should be done by a QUALIFIED and AUTHORIZED technician.**

### **3.4 Daily cleaning**

For hygienic cleanliness, it is imperative to clean chamber and spacers daily. Also clean the lid rubber to assure tight seat of the lid.

**Cleaning instructions for gas injection nozzles:** Periodically on a regular basis the gas injection nozzles must be removed with the connection tube and soaked in a food grade soap and water solution, then dried and re-installed.

## **4. TROUBLE SHOOTING:**

### **4.1 Failure during packaging cycle:**

#### **4.1.1 "COVER DOWN ERROR" message is displayed on LCD(manual units):**

The input signal of the down position switch has been lost during cycle execution.  
- Check limit switch adjustment.

### **4.2 Insufficient vacuum:**

#### **4.2.1 Leakage in the bag:**

Most frequently, insufficient vacuum in bags is due to leakage in bag and not due to any fault of the machine.

Pin-hole leak for which there is no obvious explanation is due to faulty bag material.

Pin-hole leak caused by sharp edge of the product (bone, etc.). Use bone-guard or thicker film.

Tear in bag by careless handling (sharp edge on filling table, damage made by retailer or customer).

Leakage in lateral or bottom seal, complain to supplier of bags or film.

#### **4.2.2 No leakage in the bag:**

Bag is too large, therefore the surplus of air remains visible (there is surplus of air in 0.4% of the bag volume in each bag). Use bags of suitable size.

Vacuum time is too short:

Pressure bar is jammed and closes opening of bag during evacuation.

#### **4.2.3 Insufficient vacuum in chamber:**

If troubles described under 4.2.1 and 4.2.2 do not apply, there is something wrong with the evacuation. To find the leakage quickly, check for leaks with a precision

vacuumeter, going back step by step from the chamber to the pump.

At the chamber (measuring point at base of valve) at maximum time of evacuation. If more than 6 torr, proceed directly to the pump, if more than 3 torr: have pump service by pump supplier. If pressure at pump is good, reconnect hoses to pump and measure again.

Verify at vacuum hose connections and valve connections.

When proceeding this way, starting from pump, loss of pressure per step must not exceed 0.5 to 1 torr.

Warning: Verify connections of measuring equipment before verifying machine.

Most frequent points of leakage: lid gasket, damaged vacuum hose or loose hose clamps.

### **4.3 Faulty seal:**

#### **4.3.1 Insufficient seal:**

Damaged teflon or silicone rubber.

Sealing pressure too low, bellows leaking or pressure bar jammed.

Leakers in seal: heating wire mechanically damaged (knicked) or silicone rubber uneven.

#### **4.3.2 No seal:**

Sealing wire burnt.

Faulty contact in sealing circuit.

Sealing transformer burnt through.

Contactors does not work.

#### **4.3.3 Permanent sealing current:**

Contactors is jammed check sealing transformer for damage through overload.

#### **4.3.4 Seal does not stick:**

Insufficient layer of polyethylene (inferior quality of bags).

Seal area extremely contaminated by fat or meat juice. Use filling aid.

Sealing temperature is too low (when using very thick films).

Warning: Do not increase sealing time more than really necessary; higher temperature will reduce working life of teflon and silicone rubber.

### **4.4 Fault in the valve:**

Vacuum or air valve does not open.

Check whether there is voltage on the magnetic valves during their period of operation. If there is no voltage a wire is broken or the PC board is damaged.  
Lid does not open at the end of the cycle; air enters, but there is still 20 - 40% vacuum in chamber. Vacuum valve does not close.

#### **4.5 MC40 Control board failure**

NOTE: Refer to menu structure on page 13.

This board software is allowing access to a "Diagnostics Menu". Only qualified service technicians are authorized to access this menu by entering a security password.

By acceding either the "D1 input test" feature or the "D2 output test" feature, a trained technician will be able to quickly know the origin of the problem: pump, sealing system, pneumatic problem, security switches problem, etc...

Keep in mind that in most cases trouble is due to a leakage, loose electrical Keynesian or evident damage to the main component: vacuum pump, valves..., electrical contactors, thermal overload, fuses holder or transformer.

For assistance do not hesitate to contact your local service technicians.

#### **5. Regular maintenance:**

Routine controls to be made at regular intervals:

Check teflon for wear.

Check silicone rubber for burnt spots and smooth even position.

Check pressure bar for jamming.

Check lid sealing for damage and hardened spots.

Check switch-point of micro switch, adjust if necessary.

Check evacuation hose for damage (contraction of diameter, or abrasions).

Check vacuum connections for tightness.

Check oil in pump (oil level in view glass; add if necessary. Regular change of oil - necessity indicated by change of color).

Check vacuum in chamber with precision vacuumeter.

Check function of cycle with various settings of timers.

# 004A4142

ITEM	PART #	DESCRIPTION	QT.
1	004B0229	VACUUM PRE-ASSEMBLY	1
2	005B0266	COVER ASSEMBLY	1
3	004A1224	SPRING PRE-ASSEMBLY	2
4	005E0832	MC-40 FRONT PANEL ASSEMBLY	1
5	004A4144	VALVE ASSEMBLY VACCUM SENSOR	1
6	004A4133	VALVE ASSEMBLY PUMP	1
7	004C3857	REAR PANNEL PRE-ASS'Y	1
8	051-0740	WASHER 1/4" FLAT S/S	8
9	051-0581	NUT 1/4"-20 NYLON LOCK S/S	4
10	051-0930	BOLT M6 x 10 S/S	4
11	004A4112	NSF FOOT	4
12	004A3374	LIMIT SWITCH ASS'Y	1
13	004-0042	ELEC. SUPPORT PRE-ASS'Y	1
14	036-0400	WIRE CONNECT. 3/8" NPT CD09/O-RING/NUT	2
15	036-0200	GROMMET 5/8"IDx1 1/8"OD RUBBER	1
16	036-0390	CABLE CONNECT.3/8"-1/2"METAL	1
17	005-0532	BELLOWS ASSEMBLY	1
18	002-0029	LEFT SEAL BAR GUIDE BLOCK	1
19	002-0030	RIGHT SEAL BAR GUIDE BLOCK	1
20	005A0278	FILLER PLATE ASS'Y	1
21	005A0364	HALF FILLER PLATE ASS'Y	2
22	005A1584	MC-40 FRONT PANEL ASSEMBLY (BERKEL)	1

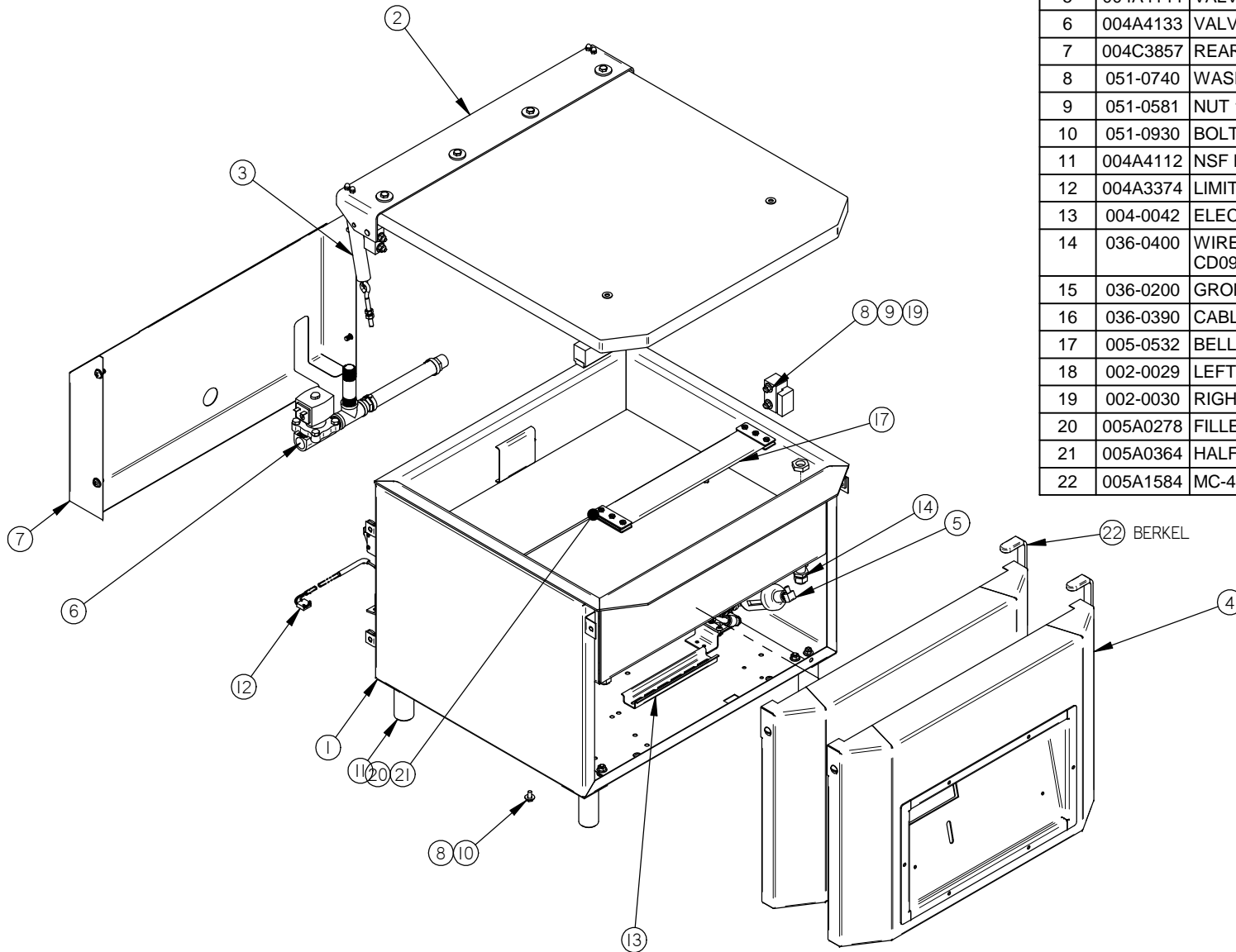

MACHINE	<b>350</b>		DEPT. TOL.	METRIC	INCH	SIPROMAC ST-GERMAIN DE GRANTHAM QUEBEC CANADA
PART	<b>MACHINE ASSEMBLY</b>		USINAGE	± 0.1	± 0.004"	
			TOLERIE	± 0.5	± 0.020"	
			SOUDEAGE	± 0.5	± 0.020"	
ITEM	CNC	DEPT.	N.T.S.		QTY.	1
MAT.	DWG BY <b>S.L.</b>	DATE <b>13-11-22</b>			NO.	<b>004A4142</b>
	APP. BY	DATE				

A	BERKEL OPTION ADDED	15-02-24	SBU
LET.	MODIFICATION	DATE	INT.

# 004A4136

ITEM	PART #	DESCRIPTION	QT.
1	004B0230	VACUUM PRE-ASSEMBLY	1
2	005B0481	COVER ASSEMBLY	1
3	004A1224	SPRING PRE-ASSEMBLY	2
4	005E0832	MC-40 FRONT PANEL ASSEMBLY	1
5	004B4134	VALVE ASSEMBLY VACCUM SENSOR	1
6	004A4133	VALVE ASSEMBLY PUMP	1
7	004C3857	REAR PANNEL PRE-ASS'Y	1
8	051-0740	WASHER 1/4" FLAT S/S	12
9	051-0581	NUT 1/4"-20 NYLON LOCK S/S	8
10	051-0930	BOLT M6 x 10 S/S	4
11	004A4112	NSF FOOT	4
12	004A3374	LIMIT SWITCH ASS'Y	1
13	004-0042	ELEC. SUPPORT PRE-ASS'Y	1
14	036-0400	WIRE CONNECT. 3/8" NPT CD09/O-RING/NUT	4
15	036-0200	GROMMET 5/8"IDx1 1/8"OD RUBBER	1
16	036-0390	CABLE CONNECT.3/8"-1/2"METAL	1
17	005-0532	BELLOWS ASSEMBLY	1
18	002-0029	LEFT SEAL BAR GUIDE BLOCK	2
19	002-0030	RIGHT SEAL BAR GUIDE BLOCK	2
20	005A0365	FILLER PLATE ASS'Y	2
21	036-0400	WIRE CONNECTOR 3/8" NPT NUT	2
22	005A1584	MC-40 FRONT PANEL ASSEMBLY (BERKEL)	1
23	001A0564	VALVE SUPPORT	1
24	051-0143	SCREW 10-24 x 3/8" PAN PHIL S/S	2
25	051-0571	NUT #10-24 S/S	2

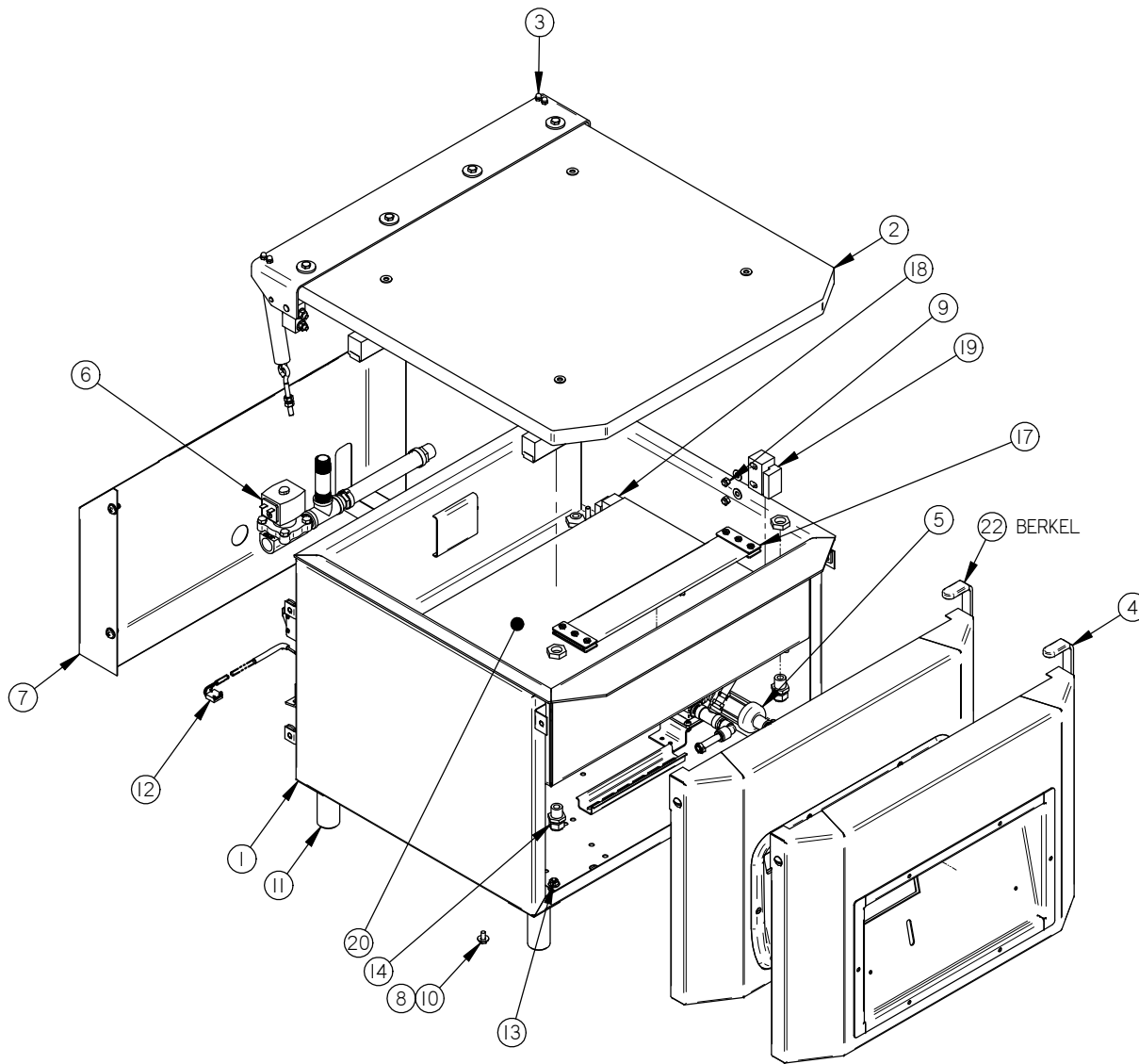

A	BERKEL OPTION ADDED	15-02-23	SBU
LET.	MODIFICATION	DATE	INT.

MACHINE		<b>350D</b>		DEPT. TOL.	METRIC	INCH	SIPROMAC ST-GERMAIN DE GRANTHAM QUEBEC CANADA
PART		MACHINE ASSEMBLY		USINAGE	± 0.1	± 0.004"	
ITEM		CNC		TOLERIE	± 0.5	± 0.020"	
MAT.		APP. BY		S.L.	DATE	13-11-22	N.T.S.
							DEPT. M
							QTY. 1
							<b>004A4136</b>

# 005C0610

ITEM	PART #	DESCRIPTION	QT.
1	004A4142	MACHINE ASSEMBLY	1
2	005B1031	STAND ASSEMBLY 19" (OPTION)	1
3	125-1021	BUSCH KB-0020 220-240V/1PH/50-60HZ	1
4	114-2009	SILENCER 1/2 NPT TOPRING	1
5	005A1424	GAS OPTION	1
6	005A1420	SOFT AIR OPTION	1
7	005A1421	AIR OPTION	1
8	005A1355	SEAL BAR ASSEMBLY W/SUPP. TWIN SEAL	1
9	005A1356	SEAL BAR ASSEMBLY W/SUPP. BAG CUT	1
10	125-1020	BUSCH KB-0020 115V/1PH/60HZ	1

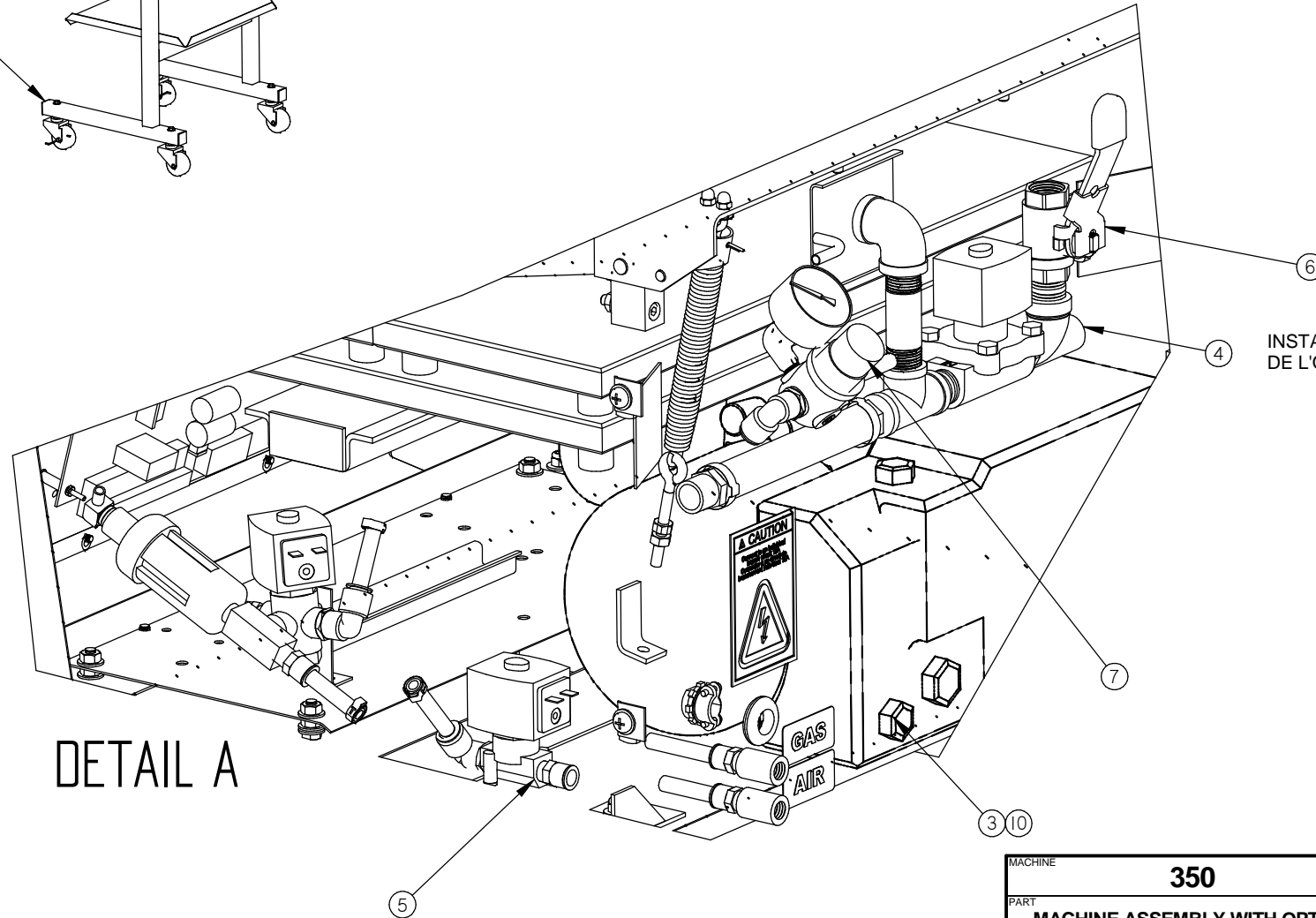
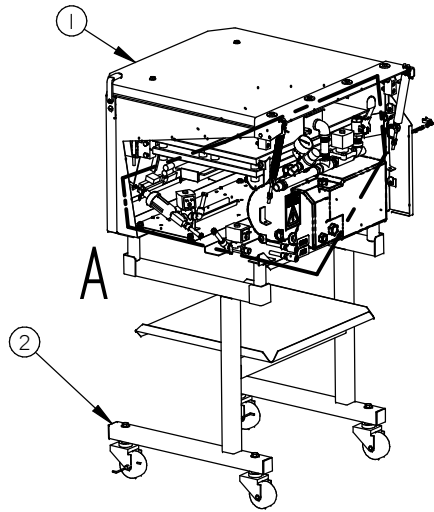

INSTALLER SUR LA VALVE LORS DE L'OPTION SOFT AIR

DETAIL A

LET.	MODIFICATION	DATE	INT.
------	--------------	------	------

MACHINE		<b>350</b>		DEPT. TOL.	METRIC	INCH	SIPROMAC ST-GERMAIN DE GRANTHAM QUEBEC CANADA
PART		<b>MACHINE ASSEMBLY WITH OPTION</b>		USINAGE	± 0.1	± 0.004"	
ITEM		CNC		TOLERIE	± 0.5	± 0.020"	
MAT.		APP. BY		S.O.	DATE	13-11-22	N.T.S.
				DEPT.	M-I		QTY. 1
							<b>005C0610</b>

# 005B0611

ITEM	PART #	DESCRIPTION	QT.
1	004A4136	MACHINE ASSEMBLY	1
2	005B1031	STAND ASSEMBLY 19" (OPTION)	1
3	125-1021	BUSCH KB-0020 220-240V/1PH/50-60HZ	1
4	114-2009	SILENCER 1/2 NPT TOPRING	1
5	005A1419	GAS OPTION	1
6	005A1420	SOFT AIR OPTION	1
7	005A1421	AIR OPTION	1
8	005A1422	TWIN SEAL OPTION	1
9	005A1423	ECO SEAL BAR OPTION	1
10	125-1020	BUSCH KB-0020 115V/1PH/60HZ	1

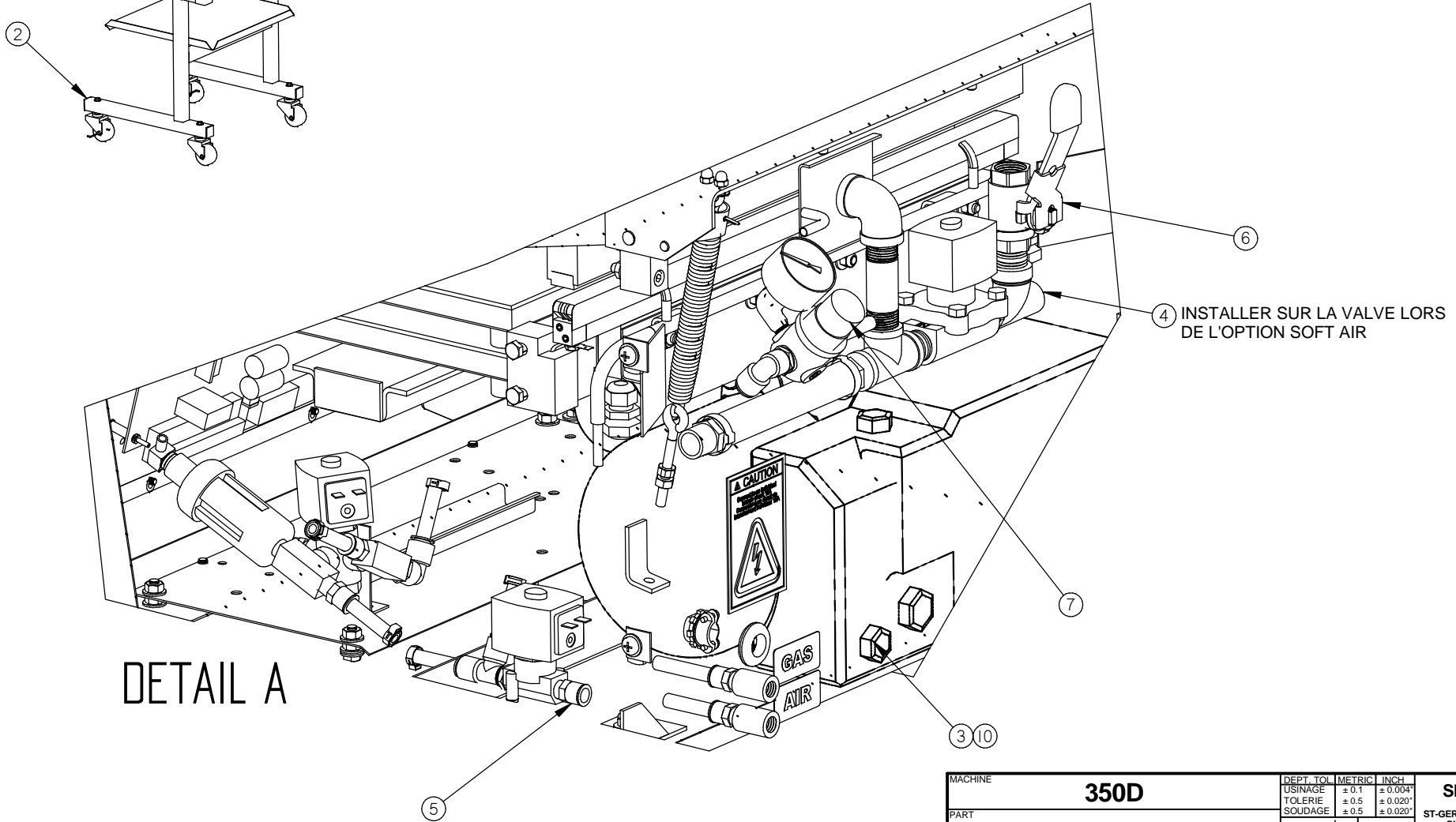
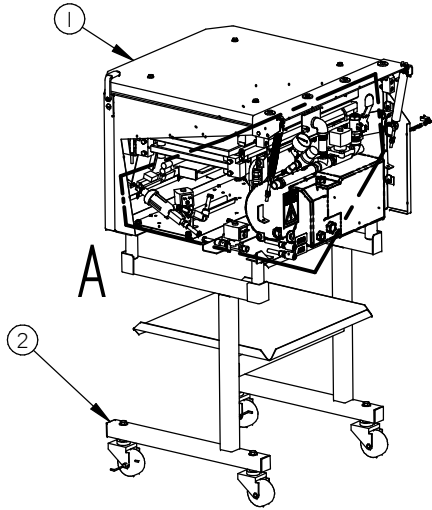

DETAIL A

LET.	MODIFICATION	DATE	INT.
------	--------------	------	------

MACHINE		<b>350D</b>		DEPT. TOL.	METRIC	INCH	SIPROMAC ST-GERMAIN DE GRANTHAM QUEBEC CANADA
PART		<b>MACHINE ASSEMBLY WITH OPTION</b>		USINAGE	± 0.1	± 0.004"	
				TOLERIE	± 0.5	± 0.020"	
				SOUDEAGE	± 0.5	± 0.020"	N.T.S.
ITEM	CNC	DEPT.	M-I	QTY.	1		
MAT.	DWG BY <b>S.L.</b>	DATE <b>13-11-22</b>	NO.	<b>005B0611</b>			
	APP. BY	DATE					

# 004A4144

ITEM	PART #	DESCRIPTION	QT.
2	100-0463	TEE 1/4" NPT S/S	1
3	114-2020	FILTER / DRYER 1/4"mnpt. X 1/4"t.p. COMP.	1
4	101-0170	ELBOW 90° 1/4MNPTx1/4"HOSE	1
5	102-0410	MALE CONN.1/4"MNPTx3/8"T.QUICK	1
6	102-0330	ELBOW 1/4" NPT X 3/8" HOSE QUICK	1
7	104-0060	TUBE 3/8"OD x 1/4"ID POLYETHYL.	2
8	105-0218	EAR CLAMP 3/8" S/S	2
9	106-00701	VALVE 3WAY 24V 1/4"NPT	1
10	001A0564	VALVE SUPPORT	1
11	100-0225	CLOSE NIPPLE 1/4" NPT SS	1
12	051-0144	SCREW #10-24 N.C 1/2"PAN PHIL. S/S	4
13	051-0571	NUT #10-24 S/S	4

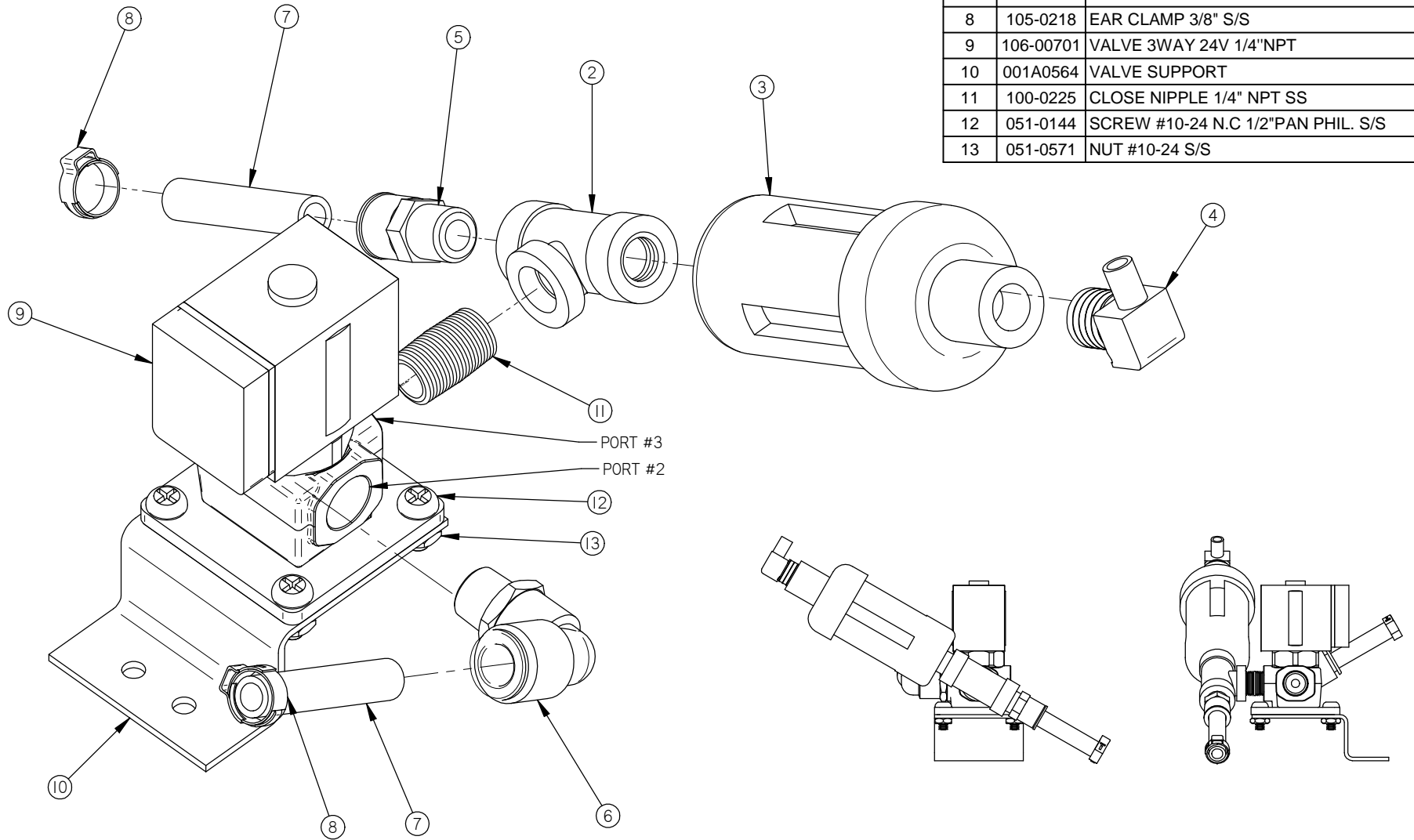

A	106-00701 WAS 106-0070	14-03-26	SBU
LET.	MODIFICATION	DATE	INT.

MACHINE		<b>300/350</b>		DEPT. TOL.	METRIC	INCH	SIPROMAC ST-GERMAIN DE GRANTHAM QUEBEC CANADA
PART		<b>VALVE ASSEMBLY VACCUM SENSOR</b>		USINAGE	± 0.1	± 0.004"	
				TOLERIE	± 0.5	± 0.020"	
ITEM		CNC		SOUDEGE		± 0.5	± 0.020"
MAT.		DWG BY <b>S.L.</b>		DATE <b>13-11-14</b>		NO. <b>004A4144</b>	
		APP. BY		DATE		DEPT. <b>M</b> QTY. <b>1</b>	

# 004B4134

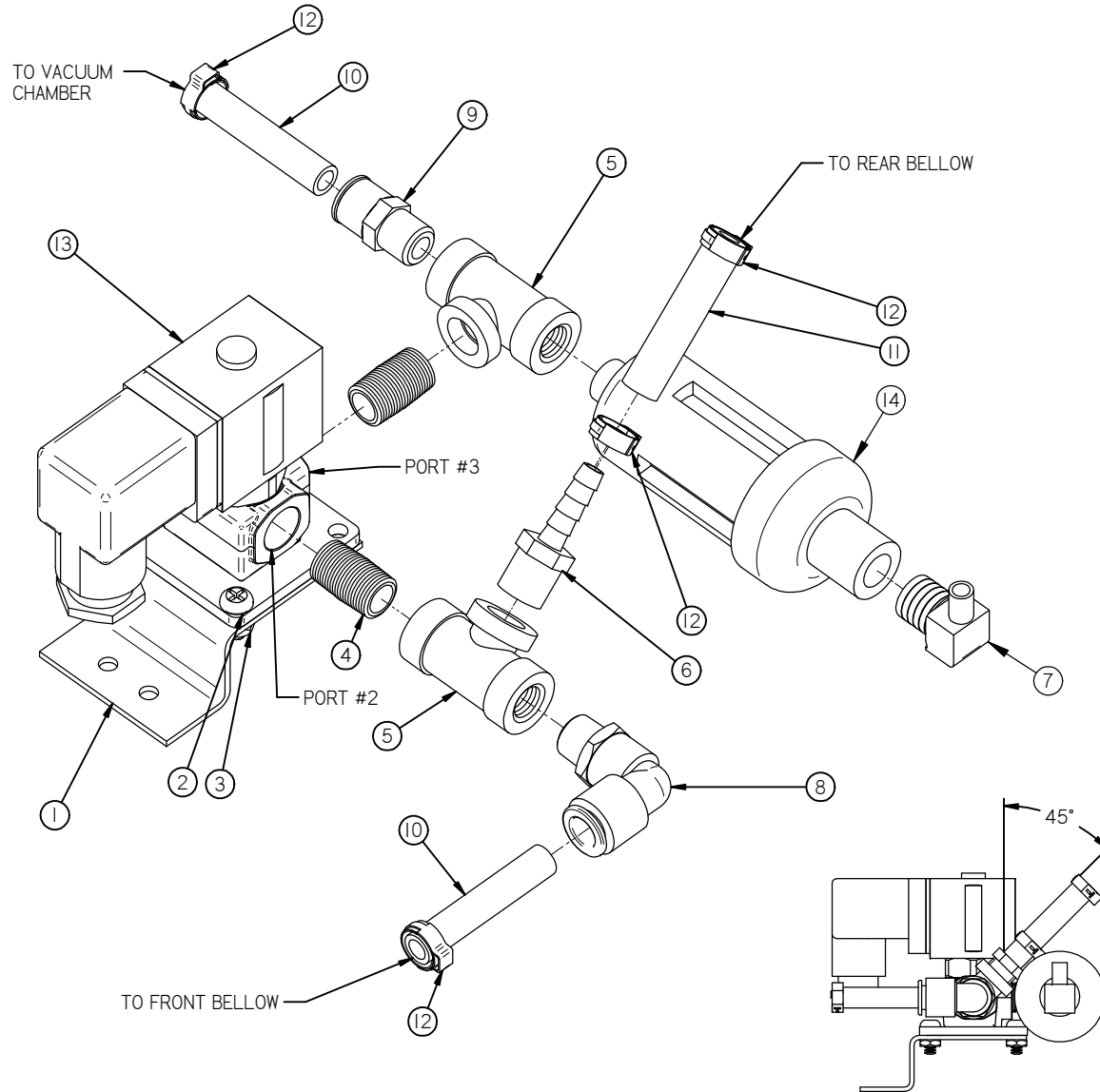

ITEM	PART #	DESCRIPTION	QT.
1	001A0564	VALVE SUPPORT	1
2	051-0144	SCREW #10-24 N.C 1/2" PAN PHIL. S/S	2
3	051-0571	NUT #10-24 S/S	2
4	100-0225	CLOSE NIPPLE 1/4" NPT SS	2
5	100-0463	TEE 1/4" NPT S/S	2
6	100-1190	STRAIGHT 1/4" MNPT x 1/4" HOSE BARB SS	1
7	101-0170	ELBOW 90° 1/4 MNPT x 1/4" HOSE	1
8	102-0330	ELBOW 1/4" NPT X 3/8" HOSE QUICK	1
9	102-0410	MALE CONN. 1/4" MNPT x 3/8" T. QUICK	1
10	104-0060	TUBE 3/8" OD x 1/4" ID POLYETHYL.	2
11	104-0102	HOSE 1/4" ID PVC BRAIDED	1
12	105-0218	EAR CLAMP 3/8" S/S	4
13	106-00701	VALVE 3WAY 24V 1/4" NPT	1
14	114-2020	FILTER / DRYER 1/4" mnpt. X 1/4" t.p. COMP.	1

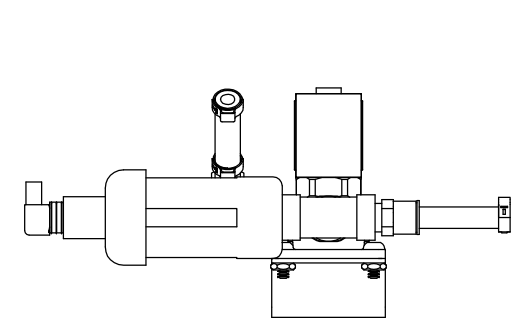

B	CHANGEMENT CONFIG	14-06-02	SBU
A	CHANGEMENT VALVE 106-00701	14-03-26	S.T
LET.	MODIFICATION	DATE	INT.

MACHINE		<b>300D/350D</b>		DEPT. TOL.	METRIC	INCH	SIPROMAC ST-GERMAIN DE GRANTHAM QUEBEC CANADA
PART		<b>VALVE ASSEMBLY VACCUM SENSOR</b>		USINAGE	± 0.1	± 0.004"	
ITEM		CNC		TOLERIE	± 0.5	± 0.020"	
MAT.		APP. BY		DATE		NO.	QTY.
		S.L.		13-11-14		N.T.S.	M 1
		DATE				<b>004B4134</b>	

# 005E0832

ITEM	PART #	DESCRIPTION	QT.
1	001E3123	FRONT PANEL	1
2	005C0583	MC-40 CONTROL BOARD	1
3	004B1651	COVER HOLD DOWN ASS'Y	1
4	051-0571	NUT #10-24 S/S	11
5	051-01865	SCREW 1/4-20x 1/2" TRUSS SLOT SS	4

INSTALLER POUR QUE LA BARRURE PUISSE BOUGER LIBREMENT SANS JEUX AXIAL.  
 INSTALL SO THAT THE LOCK CAN TURN WITHOUT AXIAL PLAY.

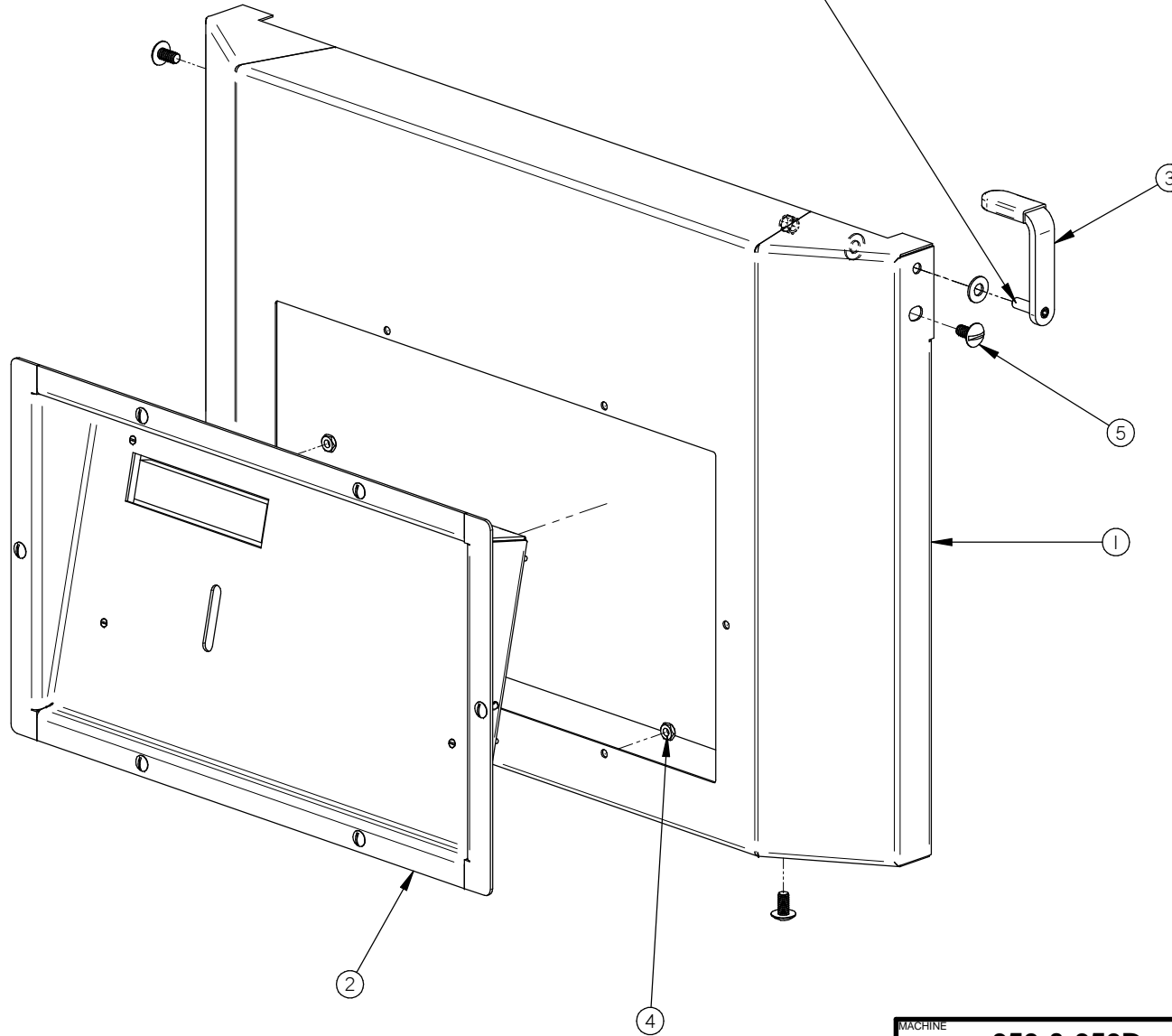

LET.	MODIFICATION	DATE	INT.
------	--------------	------	------

MACHINE		<b>350 &amp; 350D</b>		DEPT. TOL. METRIC	INCH	SIPROMAC ST-GERMAIN DE GRANTHAM QUEBEC CANADA
PART		<b>MC-40 FRONT PANEL ASSEMBLY</b>		USINAGE ± 0.1 ± 0.004"	N.T.S.	
ITEM		CNC		TOLERIE ± 0.5 ± 0.020"		
MAT.		APP. BY <b>SBU</b>		SOUDAGE ± 0.5 ± 0.020"		
		DATE <b>15-02-23</b>		DEPT.	<b>M</b>	NO. <b>005E0832</b>
						QTY. <b>1</b>

# 005C0583

ITEM	PART #	DESCRIPTION	QT.
1	001B6920	CONTROL PANEL MC-40	1
2	033-0038	MC-40 SENSOR VACUUM	1
3	051-0092	SCREW #4-40 x 1 1/4" FLAT SLT S/S	4
4	051-01081	SCREW 8-32 X 1/2" TRUSS SLOT SS	6
5	051-0540	NUT #4-40 HEX S/S	8
6	051-0713	WASHER #4 FLAT S/S	4
7	051-0715	WASHER #4 LOCK SS	4
8	058-0120	CPVC SPACER 0.120" x 1/4" x 5/8"	4
9	179-0004	NITRILE 1/2" X 1/8" AUTOCOLLANT X 1210mm long	1

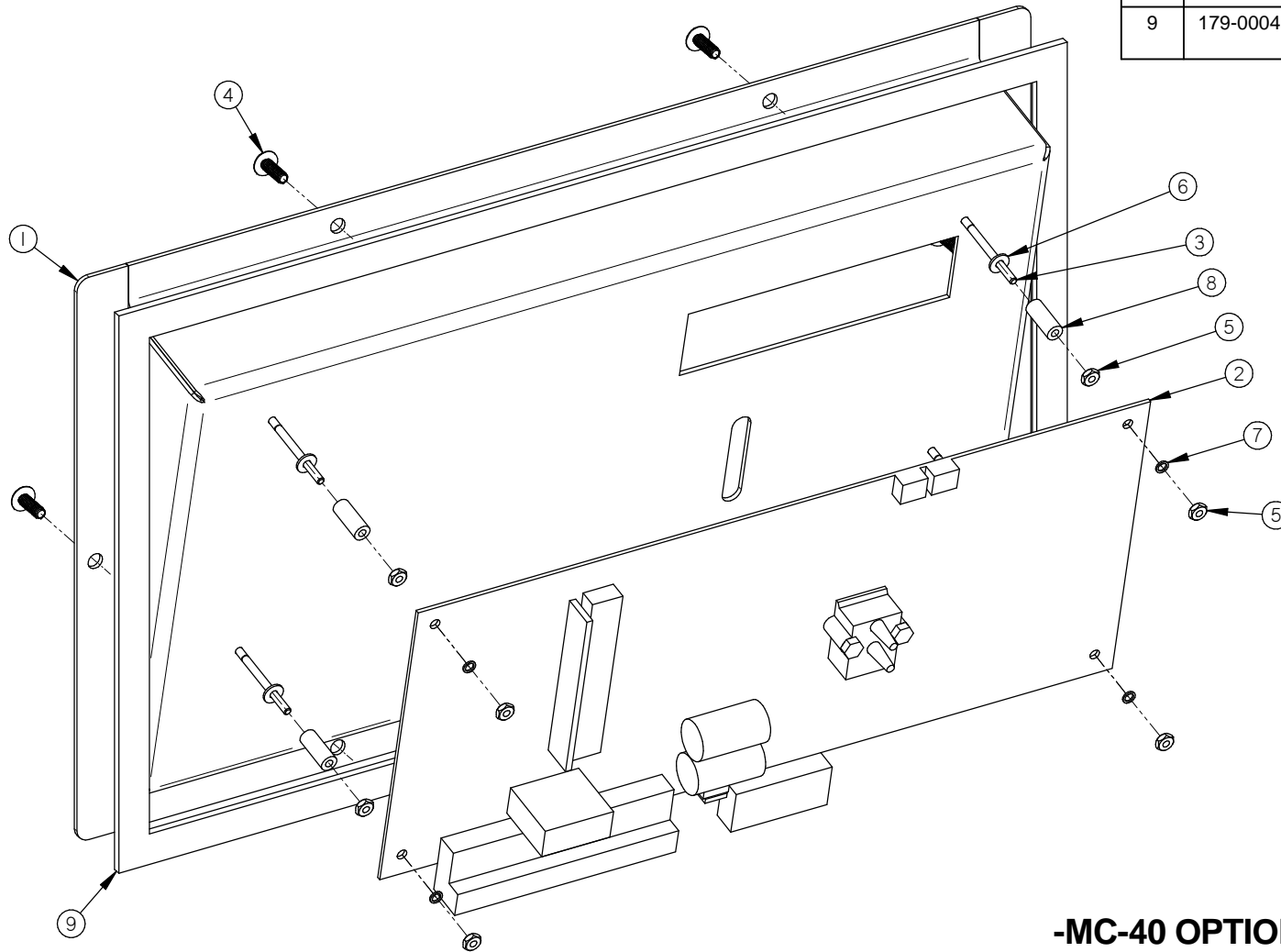

## -MC-40 OPTION-

MACHINE		<b>VACUUM</b>		DEPT. TOL.	METRIC	INCH	SIPROMAC ST-GERMAIN DE GRANTHAM QUEBEC CANADA
PART		<b>MC-40 CONTROL BOARD</b>		USINAGE	± 0.1	± 0.004"	
				TOLERIE	± 0.5	± 0.020"	
				SOUDEAGE	± 0.5	± 0.020"	N.T.S.
ITEM		CNC		DEPT.	M		QTY. 1
MAT.		3D DWG BY	SBU	DATE	15-02-23		NO. <b>005C0583</b>
		2D DWG BY	SBU	DATE	15-02-23		

A	SS INSERT	15-02-23	SBU
LET.	MODIFICATION	DATE	INT.

# 005A1584

ITEM	PART #	DESCRIPTION	QT.
1	001A6958	FRONT PANEL	1
2	005B0583	MC-40 CONTROL BOARD	1
3	004B1651	COVER HOLD DOWN ASS'Y	1
4	051-0571	NUT #10-24 S/S	6
5	179-0004	NITRILE 1/2" X 1/8" AUTOCOLLANT X 1220mm long	1
6	051-01865	SCREW 1/4-20x 1/2" TRUSS SLOT SS	4

INSTALLER POUR QUE LA BARRURE PUISSE BOUGER LIBREMENT SANS JEUX AXIAL.  
 INSTALL SO THAT THE LOCK CAN TURN WITHOUT AXIAL PLAY.

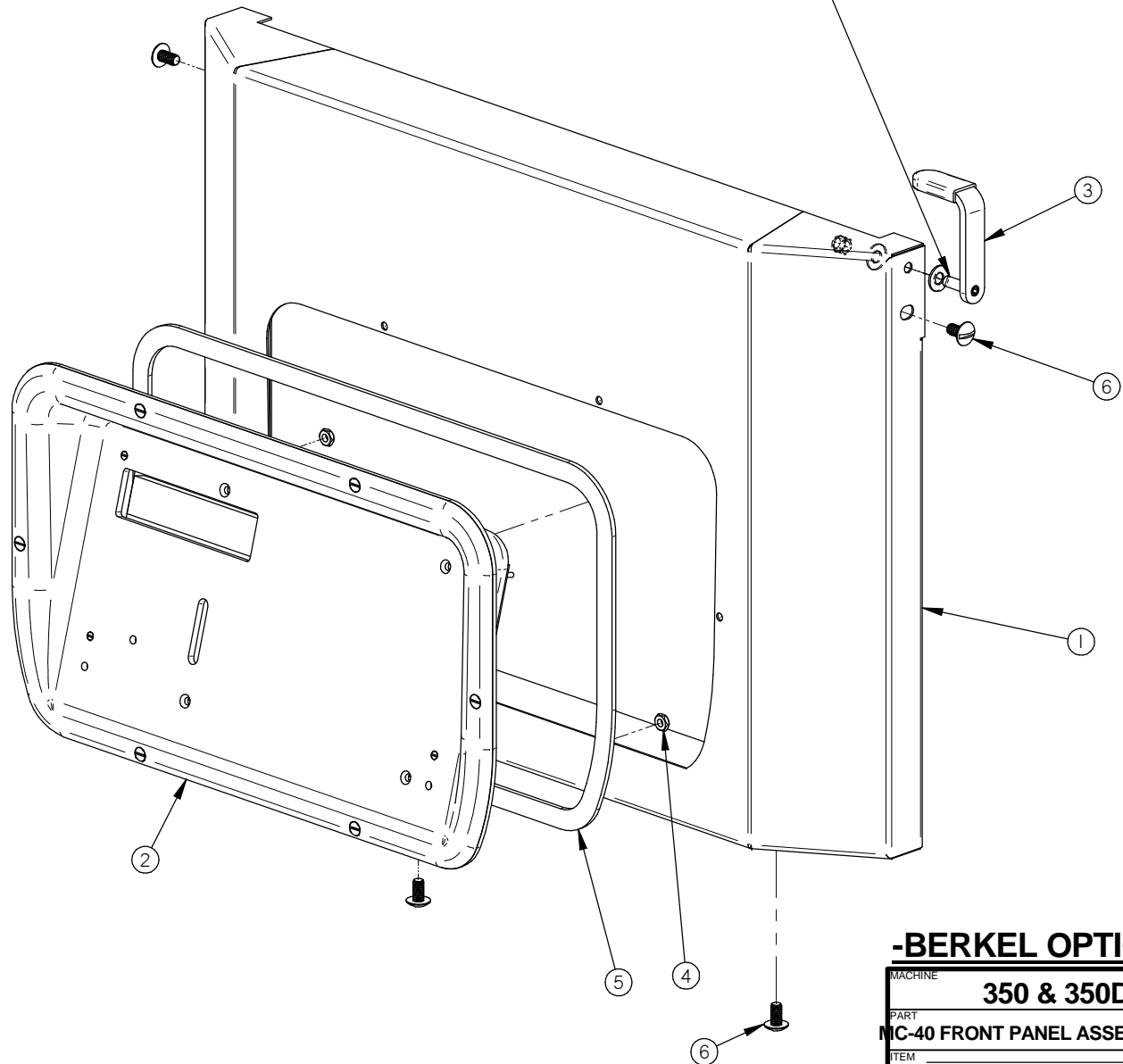

## -BERKEL OPTION -

MACHINE		DEPT. TOL. METRIC		INCH		SIPROMAC	
350 & 350D		USINAGE	± 0.1	± 0.004"	ST-GERMAIN DE GRANTHAM QUEBEC CANADA		
PART		TOLERIE	± 0.5	± 0.020"			
MC-40 FRONT PANEL ASSEMBLY (BERKEL)		SOUDAGE	± 0.5	± 0.020"			
ITEM	CNC	N.T.S.		DEPT.	M	QTY.	1
MAT.	DWG BY	DATE		NO.	005A1584		
	APP. BY	DATE					

LET.	MODIFICATION	DATE	INT.
------	--------------	------	------

# 005B0583

ITEM	PART #	DESCRIPTION	QT.
1	003A0403	CONTROL INSERT	1
2	051-0092	SCREW #4-40 x 1 1/4" FLAT SLT S/S	4
3	051-0713	WASHER #4 FLAT S/S	4
4	058-0120	CPVC SPACER 0.120" x 1/4" x 5/8"	4
5	051-0540	NUT #4-40 HEX S/S	8
6	051-0715	WASHER #4 LOCK SS	4
7	033-0038	MC-40 SENSOR VACUUM	1
8	051-01095	SCREW 8-32 x 1/2 FLAT SLOT SS	6
9	179-0004	NITRILE 1/2" X 1/8" AUTOCOLLANT X 1220mm long	1

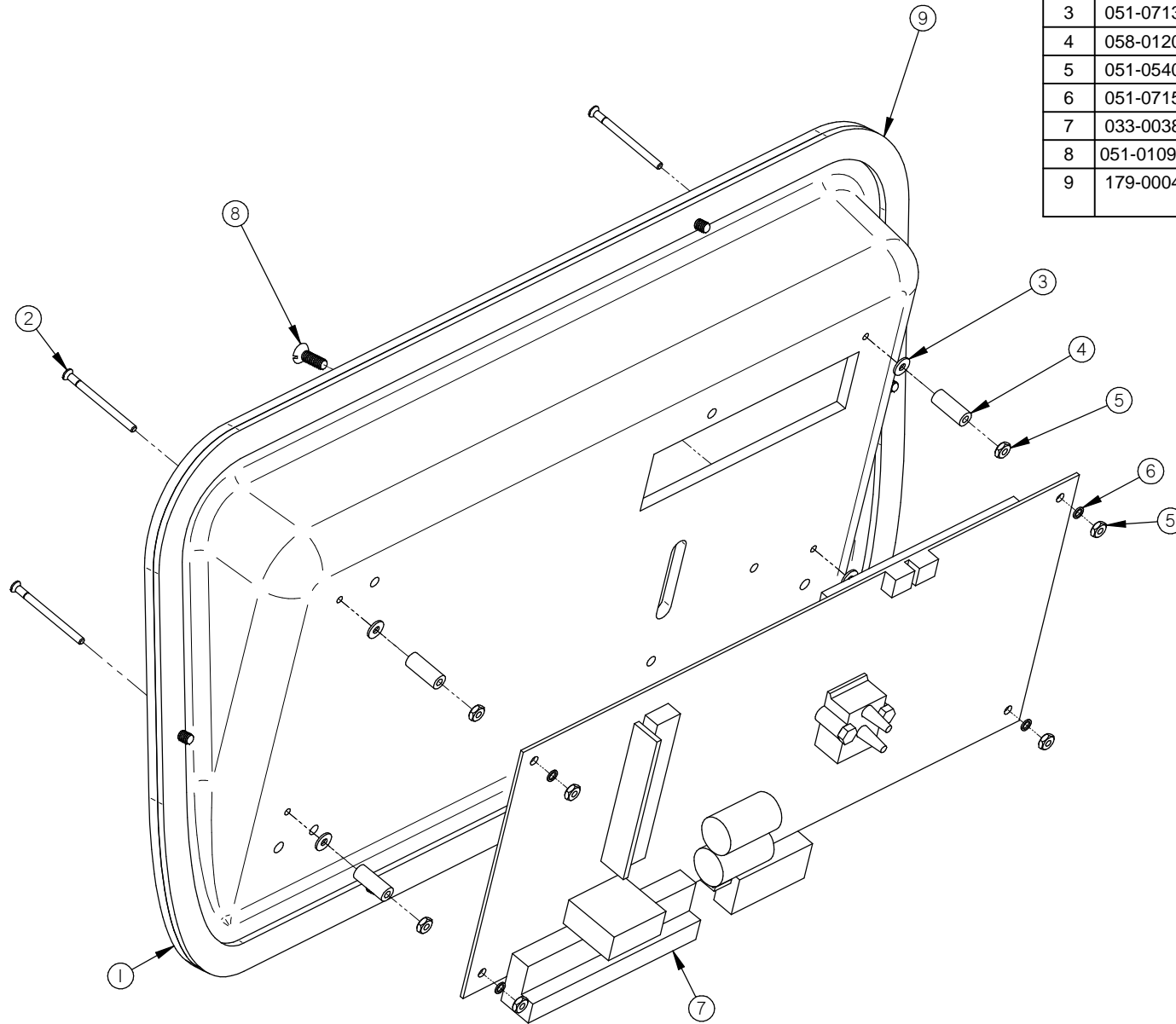

MACHINE		<b>VACUUM</b>		DEPT. TOL.	METRIC	INCH	SIPROMAC ST-GERMAIN DE GRANTHAM QUEBEC CANADA
PART		<b>MC-40 CONTROL BOARD</b>		USINAGE	± 0.1	± 0.004"	
				TOLERIE	± 0.5	± 0.020"	
				SOUDEAGE	± 0.5	± 0.020"	N.T.S.
ITEM		CNC		DEPT.	<b>M</b>		QTY. <b>1</b>
MAT.		DWG BY	<b>SBU</b>	DATE	<b>13-11-21</b>		<b>005B0583</b>
		APP. BY		DATE			

LET.	MODIFICATION	DATE	INT.
------	--------------	------	------

# 004A4133

ITEM	PART #	DESCRIPTION	QT.
1	106-0020	VALVE 2WAY 24V 1/2"NPT(G94) 60Hz	1
2	100-0230	CLOSE NIPPLE 1/2" npt, S/S	1
3	100-0465	TEE 1/2"npt. S/S	1
4	100-0330	NIPPLE 1/2" NPT X 3" SS	1
5	101-0220	STRAIGHT 1/2"MNPTx3/4" HOSE BARB BRASS	2
6	104-0110	HOSE 3/4" ID VACUUM TIGERFLEX	1
7	105-0238	EAR CLAMP 23.9-27.1 SS	2

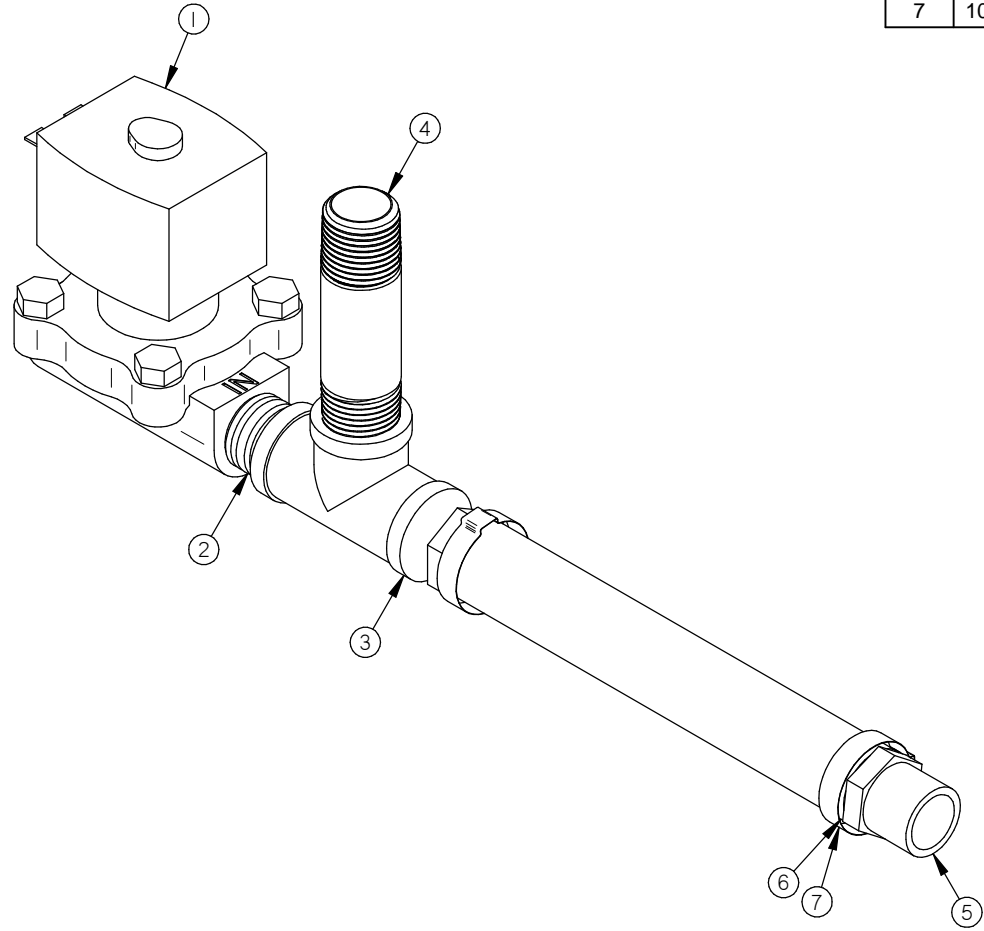

LET.	MODIFICATION	DATE	INT.
------	--------------	------	------

MACHINE	<b>350/350D</b>			DEPT. TOL.	METRIC	INCH	SIPROMAC ST-GERMAIN DE GRANTHAM QUEBEC CANADA
PART	<b>VALVE ASSEMBLY PUMP</b>			USINAGE	± 0.1	± 0.004"	
				TOLERIE	± 0.5	± 0.020"	
				SOUDEAGE	± 0.5	± 0.020"	N.T.S.
ITEM	CNC	DEPT.	M	QTY.	1		
MAT.	DWG BY	S.L.	DATE	13-11-14	NO.	<b>004A4133</b>	
	APP. BY		DATE				

# 004A4112

ITEM	PART #	DESCRIPTION	QT.
1	002A3528	NSF FOOT	1
2	051-0288	BOLT 1/4-20 x 3 1/2" S/S	1
3	051-0740	WASHER 1/4" FLAT S/S	1
4	051-0581	NUT 1/4"-20 NYLON LOCK S/S	1

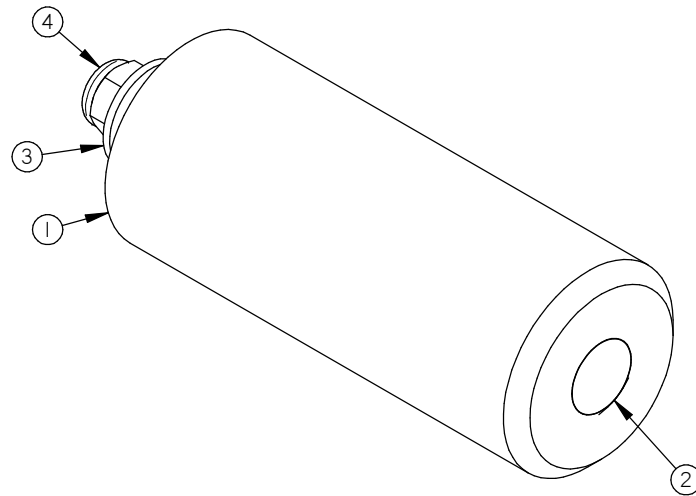

MACHINE		<b>VACUUM TABLE</b>		DEPT. TOL.	METRIC	INCH	SIPROMAC ST-GERMAIN DE GRANTHAM QUEBEC CANADA
PART		<b>NSF FOOT</b>		USINAGE	± 0.1	± 0.004"	
ITEM		CNC		TOLERIE	± 0.5	± 0.020"	
MAT.		APP. BY		DATE		NO.	4
LET.		MODIFICATION		DATE		INT.	<b>004A4112</b>

LET.      MODIFICATION      DATE      INT.

004A3374

ITEM	PART #	DESCRIPTION	QT.
1	001-0944	SUPPORT SWITCH	1
2	051-01865	SCREW 1/4"-20 NC. X 1/2" TRUSS SLOT S/S	1
3	051-0740	FLAT WASHER 1/4"φ S/S	1
4	051-0580	HEX. NUT 1/4"-20 NC. S/S	1
5	051-0080	SCREW #4-40 X 5/8" PAN SLOT S/S	2
6	051-0715	WASHER #4 LOCK S/S	2
7	051-0540	NUT #4-40 S/S	2

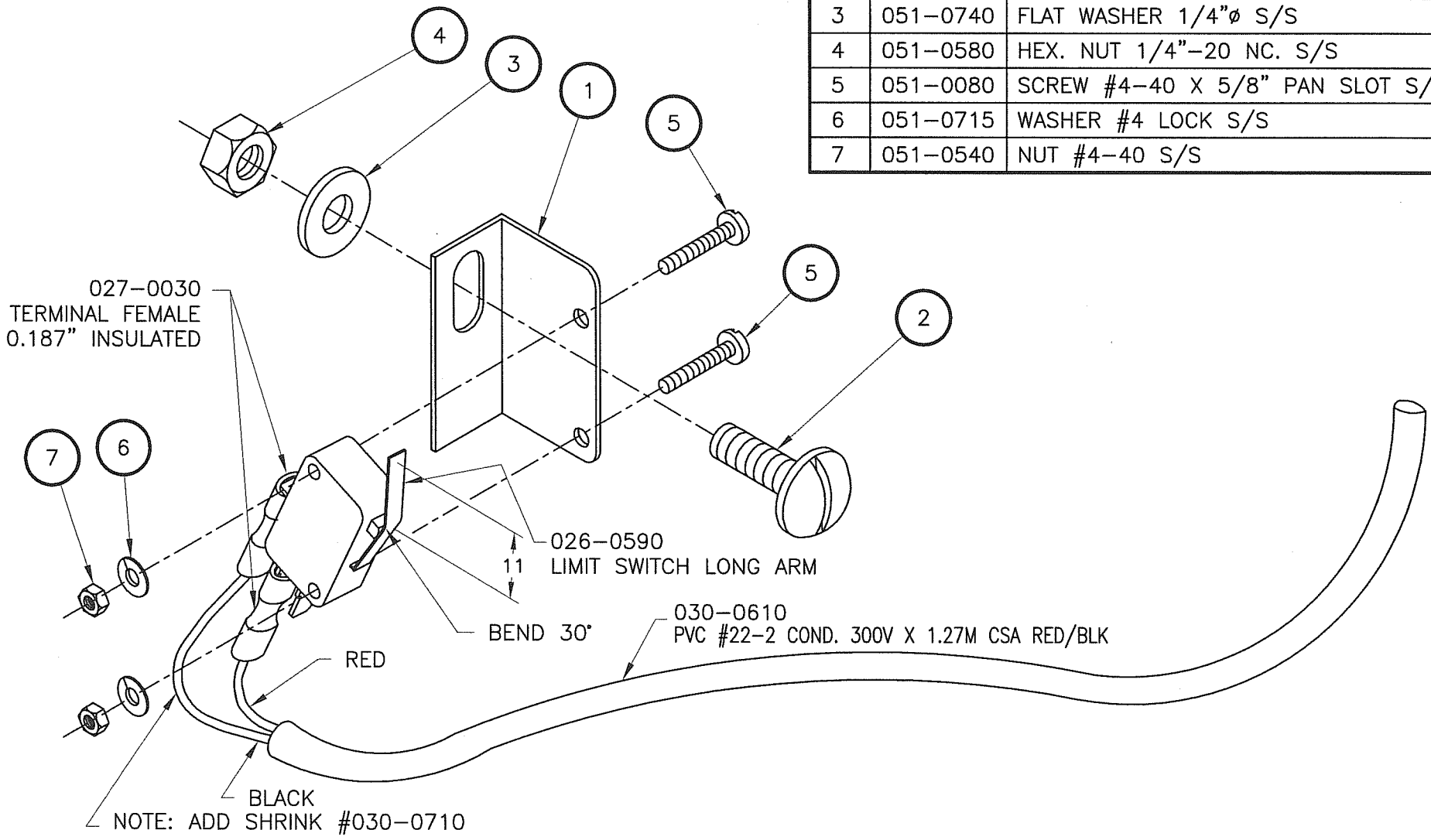

			MACHINE <b>300 &amp; 300D</b>	METRIC TOLERANCE 0. ± .5 .0 ± .05 .00 ± .005 .000 ± .0005 ANGLE ± 1°	INCH TOLERANCE .0 ± .015" .00 ± .005" .000 ± .0005" N.T.S.	<b>SIPROMAC</b> ST-GERMAIN DE GRANTHAM, QUEBEC CANADA	
			PART <b>LIMIT SWITCH ASSEMBLY</b>	ITEM: _____	CNC: _____	DEPT. <b>M-I</b>	QT. <b>1</b>
A	REDRAWN WAS 004-0261	10-11-16	D.A.	MAT: _____	DWG BY <b>D.A.</b>	DATE <b>10-11-16</b>	NO. <b>004A3374</b>
LET.	MODIFICATION	DATE	INT.		APP.	DATE _____	

004A1224

ITEM	PART #	DESCRIPTION	QT.
1	009A0152	SPRING BLACK	1
2	056-0150	EYE BOLT 1/4"-20 x 3" ZINC	1
3	051-0580	NUT 1/4"-20 S/S	2
4	056-2500	U-BOLT CABLE CLAMP THRD #10-24	1
5	051-0570	NUT #10-24 ACORN SS	2
6	008A1603	SPRING PROTECTION TUBE	1
7	056-0118	COTTER PIN 3/32" x 1" S/S	1

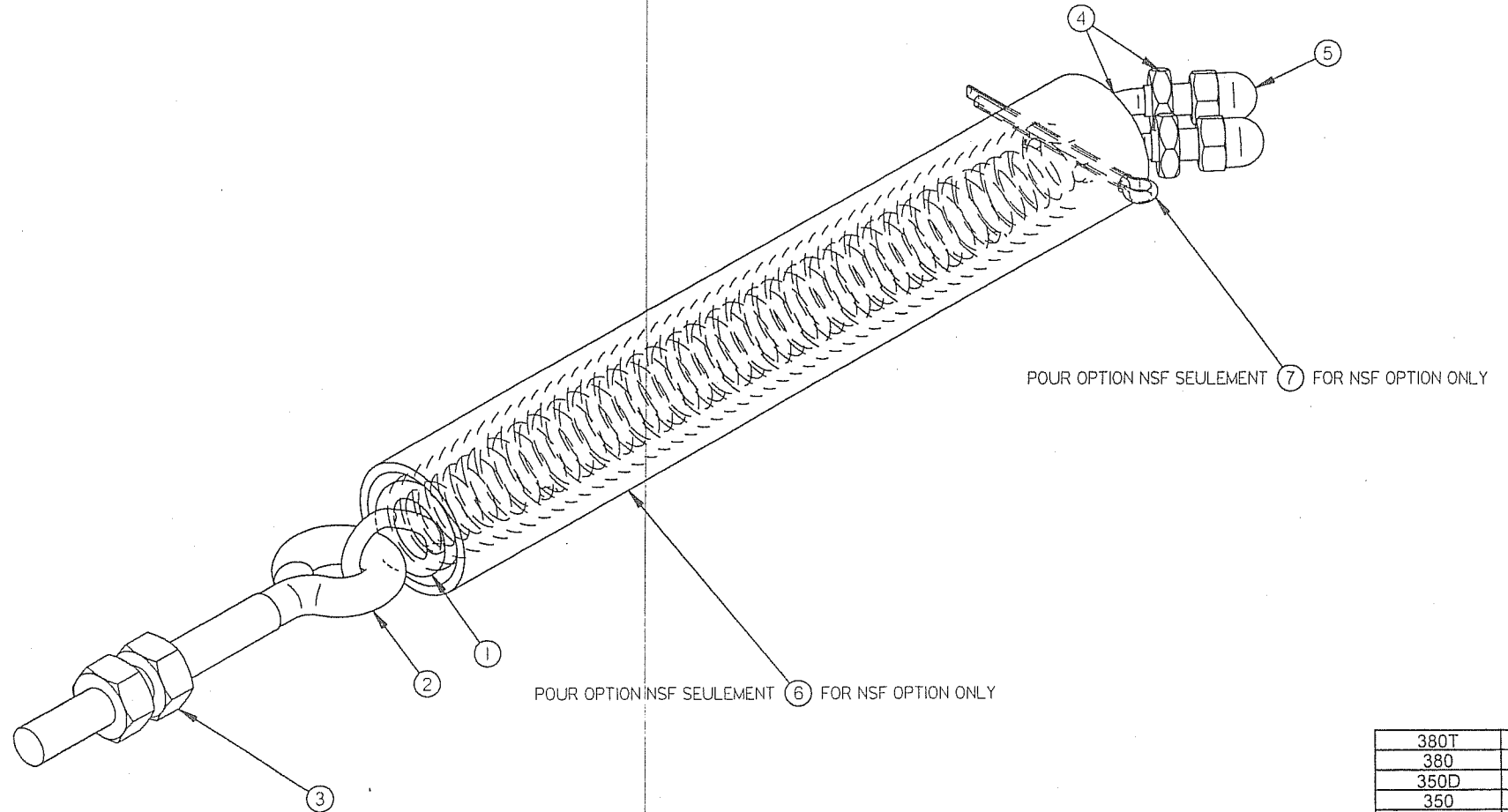

380T	4
380	2
350D	2
350	2
300	2
MACHINE	QTY

E	AJOUTER ITEM 008A1603 & 056-0118 (NSF)	10-11-09	J.G.
D	ADDED ITEM #3 051-0580 QTY : 2	05-05-05	M.A.
C	ADDED 380T	05-02-03	M.A.
B	009A0152 WAS 077-0002	04-12-07	M.A.
A	AJOUTER 380 DANS CARTOUCHE	03-09-04	J.P.
LET.	MODIFICATION	DATE	INT.

MACHINE <b>300, 350, 350D 380 &amp; 380T</b>		DEPT. TOL. METRIC INCH USINAGE ± 0.1 ± 0.004" TOLERIE ± 0.5 ± 0.020" SOUDAGE ± 0.5 ± 0.020"		ST-GERMAIN DE GRANTHAM QUEBEC CANADA	
PART <b>SPRING PRE-ASSEMBLY</b>		N.T.S.		SIPROMAC	
ITEM _____		CNC _____		DEPT. <b>M-(M)</b> QTY <b>LISTE</b>	
MAY. _____		DWG BY <b>J.T.</b> DATE <b>03-02-17</b>		NO. <b>004A1224</b>	
APP. BY _____		DATE <b>16-11-11</b>			

1005A1355

ITEM	PART #	DESCRIPTION	QT.
1	004-0352	SEAL BAR PRE-ASSEMBLY	1
2	002-0512	SEAL BAR SUPPORT	1
3	051-0256	BOLT 1/4"-20nc. X 1 3/4" CAP SKT S/S	3
4	001-1960	EXTERIOR BELLOWS COVER	1
5	001-1856	EXTERIOR BELLOWS COVER	1
6	001A6229	SEAL BAR GUIDE	2
7	051-0740	WASHER 1/4" FLAT S/S	10
8	051-0250	BOLT 1/4"-20nc. X 1 1/2" S/S	4
9	051-0581	NUT 1/4"-20 NYLON LOCK S/S	6
10	051-0230	HEX BOLT 1/4-20 x 1 1/4" SS	2

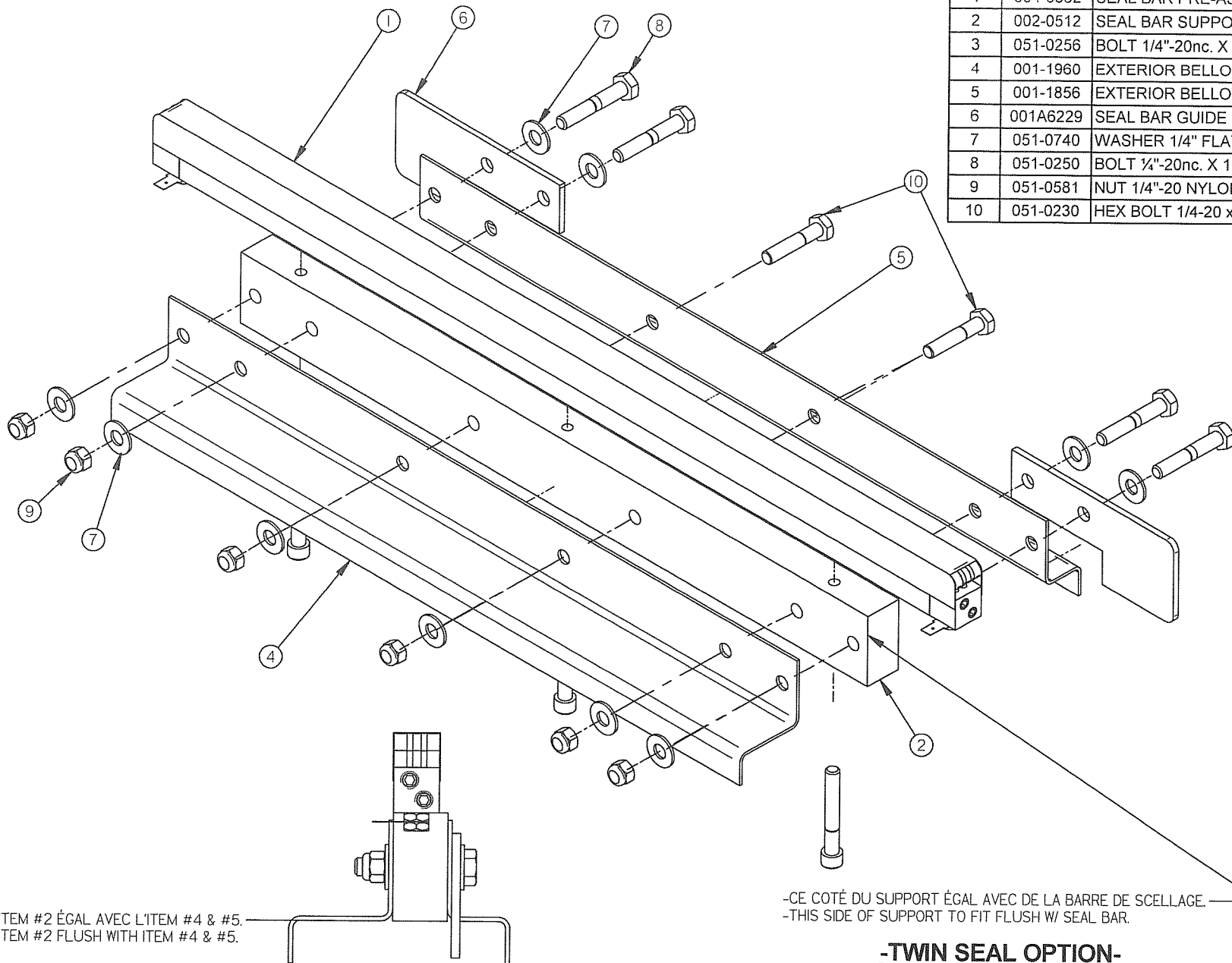

-ITEM #2 ÉGAL AVEC L'ITEM #4 & #5.  
 -ITEM #2 FLUSH WITH ITEM #4 & #5.

**-END VIEW-**

-CE CÔTÉ DU SUPPORT ÉGAL AVEC DE LA BARRE DE SCELLAGE.  
 -THIS SIDE OF SUPPORT TO FIT FLUSH W/ SEAL BAR.

350D	2
350	1
300D	2
300	1
MACHINE	QTY

**-TWIN SEAL OPTION-**

MACHINE	300, 300D, 350 & 350D		DEPT. TOL. METRIC	INCH	SIPROMAC ST-GERMAIN DE GRANTHAM QUEBEC CANADA
PART	SEAL BAR ASSEMBLY W/SUPPORT		USINAGE ± 0.1 ± 0.004"	TOLERIE ± 0.5 ± 0.020"	
ITEM	CNC		SOUDEGE ± 0.5 ± 0.020"		N.T.S.
MAT.	DWG BY J.G.	DATE 12-09-24	APP. BY		DEPT. M-I(M) QTY LIST
					NO. 005A1355

A	REDESSINE ÉTAIT 005B0046	12-09-24	J.G.
LET.	MODIFICATION	DATE	INT.

1004-0352

ITEM	#PART	DESCRIPTION	QT.
1	002-0481	SEAL BAR (TABLE)	1
2	002-0031	CONNECTOR	2
3	039-0200	SEALING ELEM. STD TWIN (2x626mm EA.)	4.31
4	052-0395	SCREW 1/4"-20 NC. X 5/16" SET HEX SKT OVAL PT	4
5	052-0250	SCREW #8-32 X 1 1/2" RND SLOT BRASS	2
6	051-0550	NUT #8-32 S/S	4
7	176-0200	TEFLON TAPE 5S ADHESIVE X 2" X (496mm EA.)	0.063
8	027-0400	CONNECTOR ADAPTOR 1/4" X #10 STUD	2

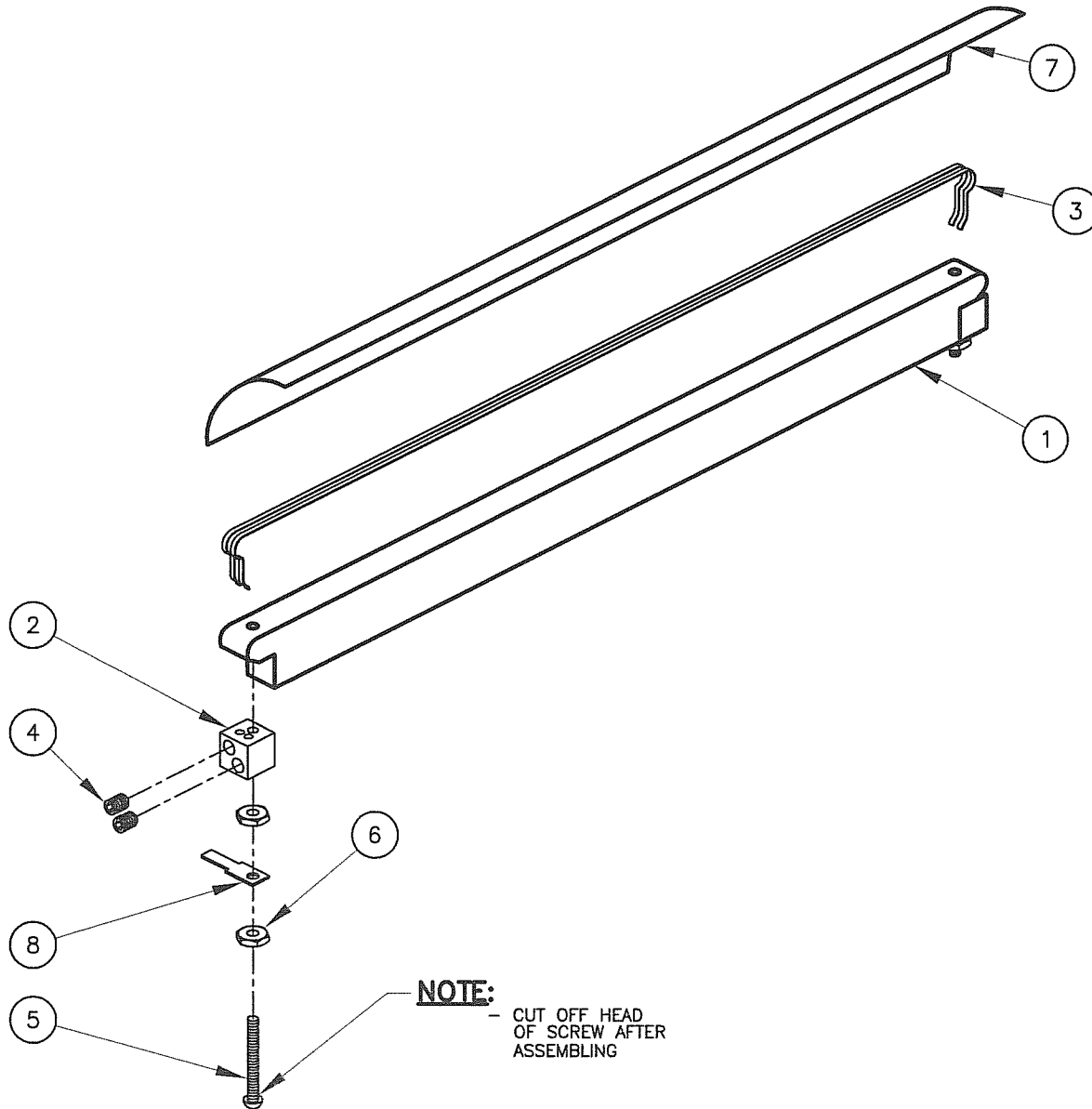

**NOTE:**  
- CUT OFF HEAD  
OF SCREW AFTER  
ASSEMBLING

450T	2
450A	2
400	2
350D	2
350	1
300D	2
300	1
MACHINE	QTÉ.

F	ADDED 300, 300D, 350 & 350D WAS 005-0267	12-09-24	J.G.
E	ADDED 450T WAS 005-0377	08-05-26	D.A.
D	MODIFICATION #A-0398 (CONNECTEUR)	04-04-19	J.G.
C	ADDED 400	99-05-06	S.L.
B	REDRAWN	98-02-10	A.P.
LET.	MODIFICATION	DATE	INT.

MACHINE		VOIR LISTE		TOLERANCE		ST-GERMAIN DE GRANTHAM QUEBEC CANADA	
PART		SEAL BAR PRE-ASSEMBLY		USINAGE	± 0.1	± 0.004"	N.T.S.
ITEM:		CNC:		TOLERIE	± 0.5	± 0.020"	
MAT:		DWG BY	A. P.	SOUDAGE	± 0.5	± 0.020"	
DATE		DATE	98-02-10	DEPT.		M-1	QT.
APP.		DATE		NO.		004-0352	

005A1356

ITEM	PART #	DESCRIPTION	QT.
1	004-0355	BAG CUT SEAL BAR PRE-ASSEMBLY	1
2	002-0512	SEAL BAR SUPPORT	1
3	051-0256	BOLT 1/4"-20nc. X 1 3/4" CAP SKT S/S	3
4	001-1960	EXTERIOR BELLOWS COVER	1
5	001-1856	EXTERIOR BELLOWS COVER	1
6	001A6229	SEAL BAR GUIDE	2
7	051-0740	WASHER 1/4" FLAT S/S	10
8	051-0250	BOLT 1/4"-20nc. X 1 1/2" S/S	4
9	051-0581	NUT 1/4"-20 NYLON LOCK S/S	6
10	051-0230	HEX BOLT 1/4-20 x 1 1/4" SS	2

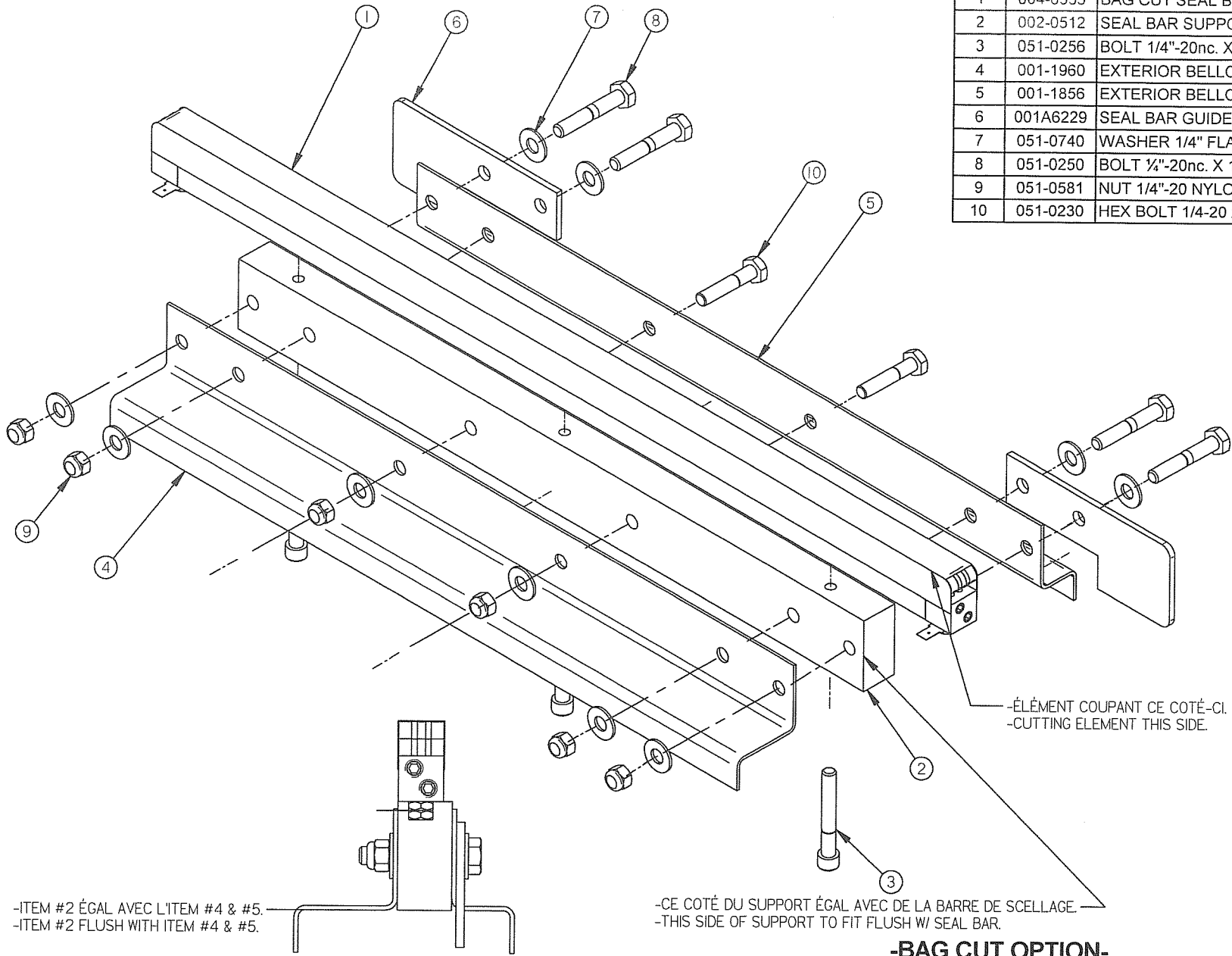

-ÉLÉMENT COUPANT CE CÔTÉ-CI.  
-CUTTING ELEMENT THIS SIDE.

-ITEM #2 ÉGAL AVEC L'ITEM #4 & #5.  
-ITEM #2 FLUSH WITH ITEM #4 & #5.

-CE CÔTÉ DU SUPPORT ÉGAL AVEC DE LA BARRE DE SCELLAGE.  
-THIS SIDE OF SUPPORT TO FIT FLUSH W/ SEAL BAR.

**-END VIEW-**

**-BAG CUT OPTION-**

350D	2
350	1
300D	2
300	1
MACHINE	QTY

MACHINE <b>300, 300D, 350 &amp; 350D</b>		DEPT. TOL. METRIC INCH	SIPROMAC ST-GERMAIN DE GRANTHAM QUEBEC CANADA
PART <b>SEAL BAR ASSEMBLY W/SUPPORT</b>		USINAGE ± 0.1 ± 0.004 TOLERIE ± 0.5 ± 0.020 SOUDAGE ± 0.5 ± 0.020	
ITEM _____		N.T.S.	
APP. BY	J.G.	DATE	12-09-24
REVISION		DATE	
A		REDESSINE ETAIT 005B0558	12-09-24 J.G.
LET.		MODIFICATION	DATE INT.
		NO. <b>005A1356</b>	

A	REDESSINE ETAIT 005B0558	12-09-24	J.G.
LET.	MODIFICATION	DATE	INT.

1004-0355

ITEM	#PART	DESCRIPTION	QT.
1	002-0481	SEAL BAR	1
2	002-0031	CONNECTOR	2
3	039-0230	REFLEX BAND 2.5MM (626mm EA.)	0.063
4	039-0270	"T" PROFILE CUT. ELEM. (626mm EA.)	0.063
5	052-0395	SCREW 1/4"-20 NC. X 5/16" SET HEX SKT OVAL PT	4
6	052-0250	SCREW #8-32 X 1 1/2" RND SLOT BRASS	2
7	051-0550	NUT #8-32 S/S	4
8	176-0200	TEFLON TAPE 5S ADHESIVE X 2" X (496mm EA.)	0.063
9	027-0400	CONNECTOR ADAPTOR 1/4" X #10 STUD	2

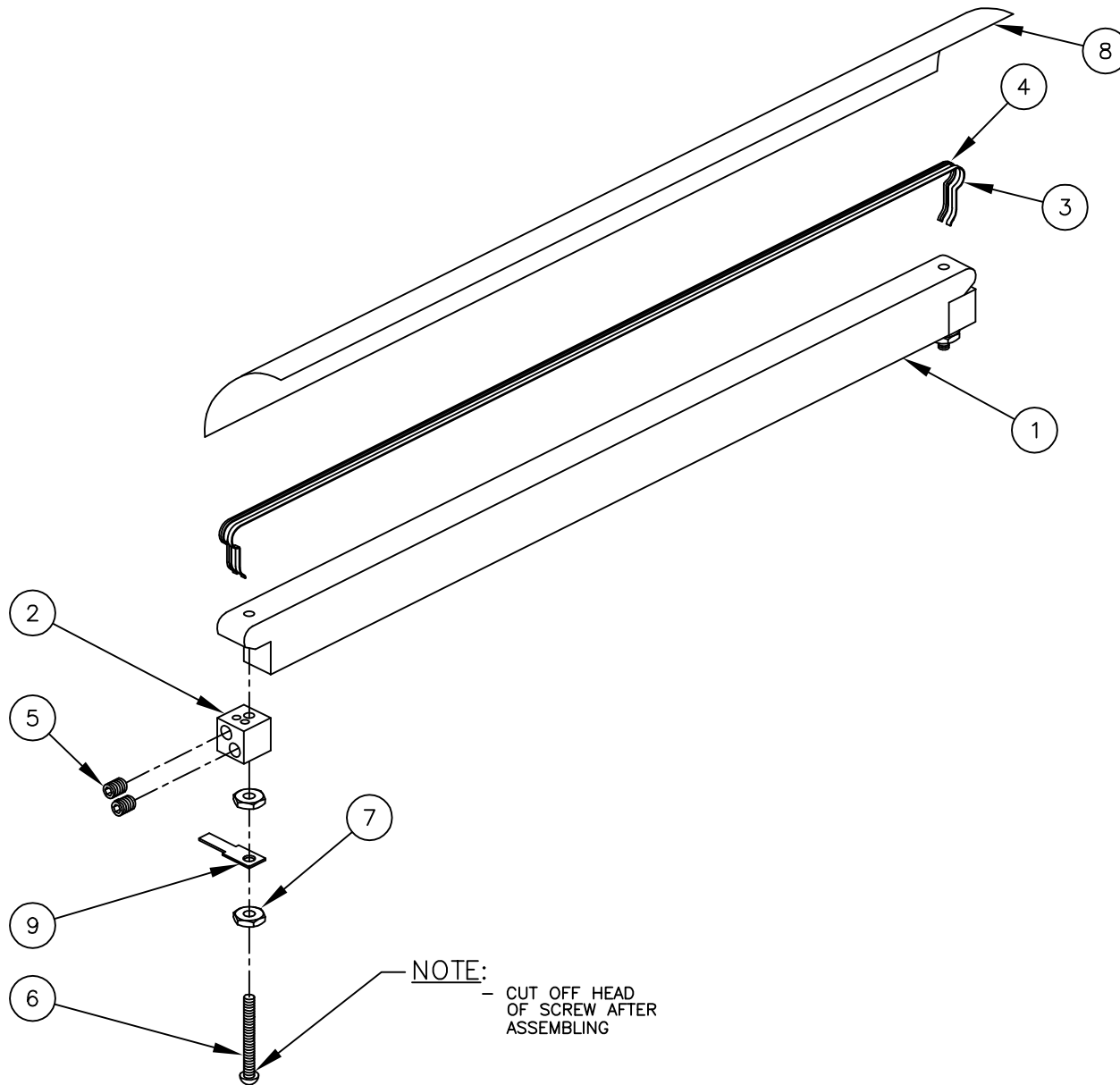

NOTE: - CUT OFF HEAD OF SCREW AFTER ASSEMBLING

-BAG CUT OPTION-

450T	2
450A	2
400	2
350D	2
350	1
300D	2
300	1
MACHINE	QTÉ.

MACHINE	VOIR LISTE		TOLERANCE	INCH	SIPROMAC ST-GERMAIN DE GRANTHAM, QUEBEC CANADA
PART	SEAL BAR PRE-ASSEMBLY		USINAGE ± 0.1	± 0.004"	
			TOLERIE ± 0.5	± 0.020"	
			SOUDAGE ± 0.5	± 0.020"	
ITEM:	CNC:			M-1	QT. LISTE
MAT:	DWG BY	A.P.	DATE 98-02-10	NO.	004-0355
	APP.		DATE		

F	ADDED 300, 300D, 350 & 350D WAS 005-0267	12-09-24	J.G.
E	ADDED 450T WAS 005-0383	08-05-26	D.A.
D	MODIFICATION #A-0398 (CONNECTEUR)	04-04-19	J.G.
C	ADDED 400	99-05-06	S.L.
B	REDRAWN	98-02-10	A.P.
LET.	MODIFICATION	DATE	INT.

# 004B0173

ITEM	PART #	DESCRIPTION	QT.
1	002B0377	UPPER SEAL BAR SUPPORT	1
2	008A0291	UPPER SEAL BAR RUBBER	1

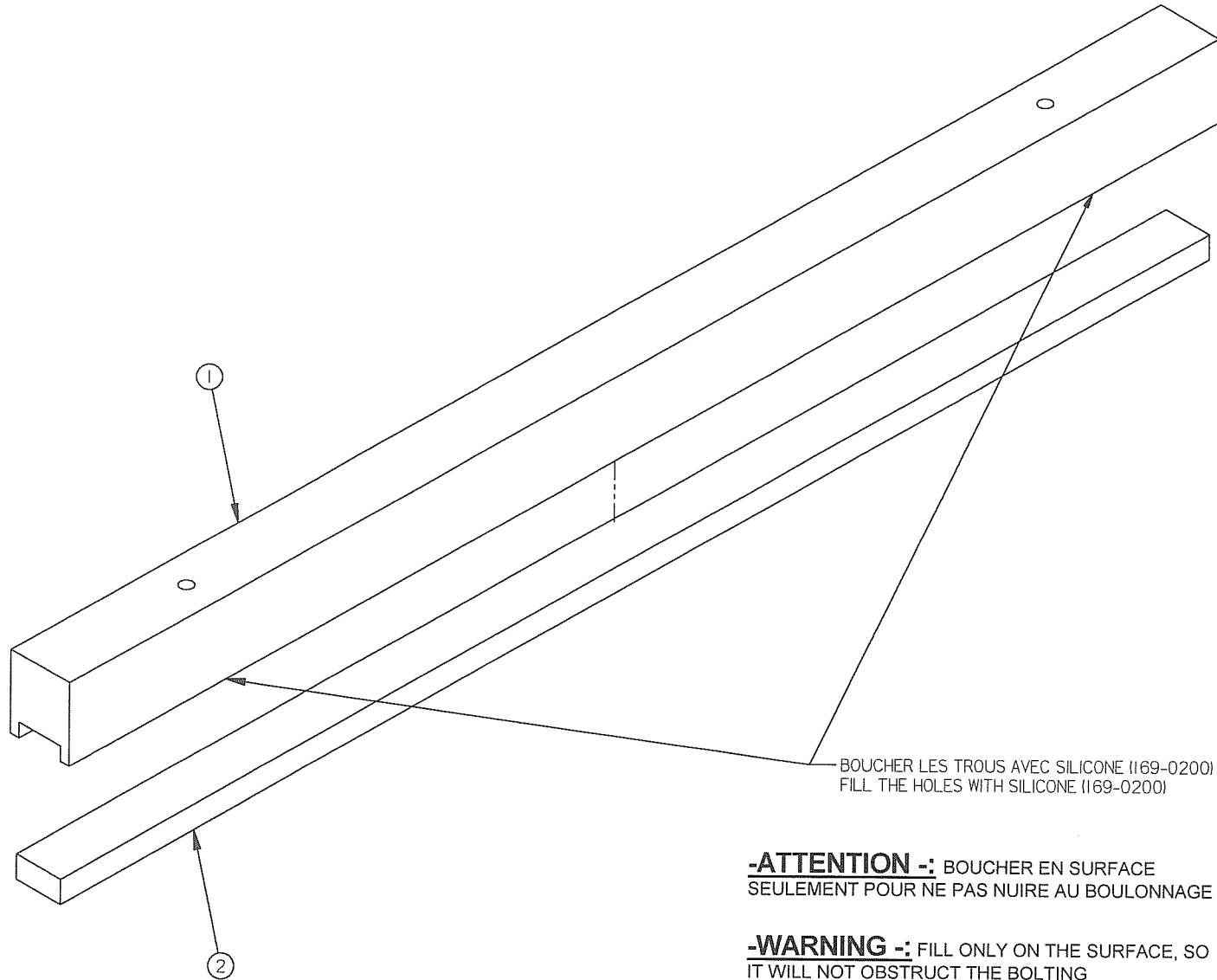

350D	2
350	1
300D	2
300	1
MACHINE	QTY

MACHINE <b>300, 300D, 350 &amp; 350D</b>		DEPT. TOL. METRIC	INCH	SIPROMAC ST-GERMAIN DE GRANTHAM QUEBEC CANADA
PART UPPER SEAL BAR PRE-ASS'Y		USINAGE ± 0.1 ± 0.004"	TOLERIE ± 0.5 ± 0.020"	
ITEM _____		SOUDDAGE ± 0.5 ± 0.020"		N.T.S.
MAT. _____		CNC _____	DEPT. M-(M)	QTY LISTE
APP. BY _____		DWG BY J.G.	DATE 12-10-15	NO 004B0173

F	REDESSINE MODIF. #A-462	12-10-15	J.G.
LET.	MODIFICATION	DATE	INT.

005A0278

ITEM	PART #	DESCRIPTION	QT.
1	008A0270	FILLER PLATE	1
2	003-0080	FILLER PLATE FOOT	4
3	054-0019	METAL SCREW #10x1"FLAT PHIL S/S	4

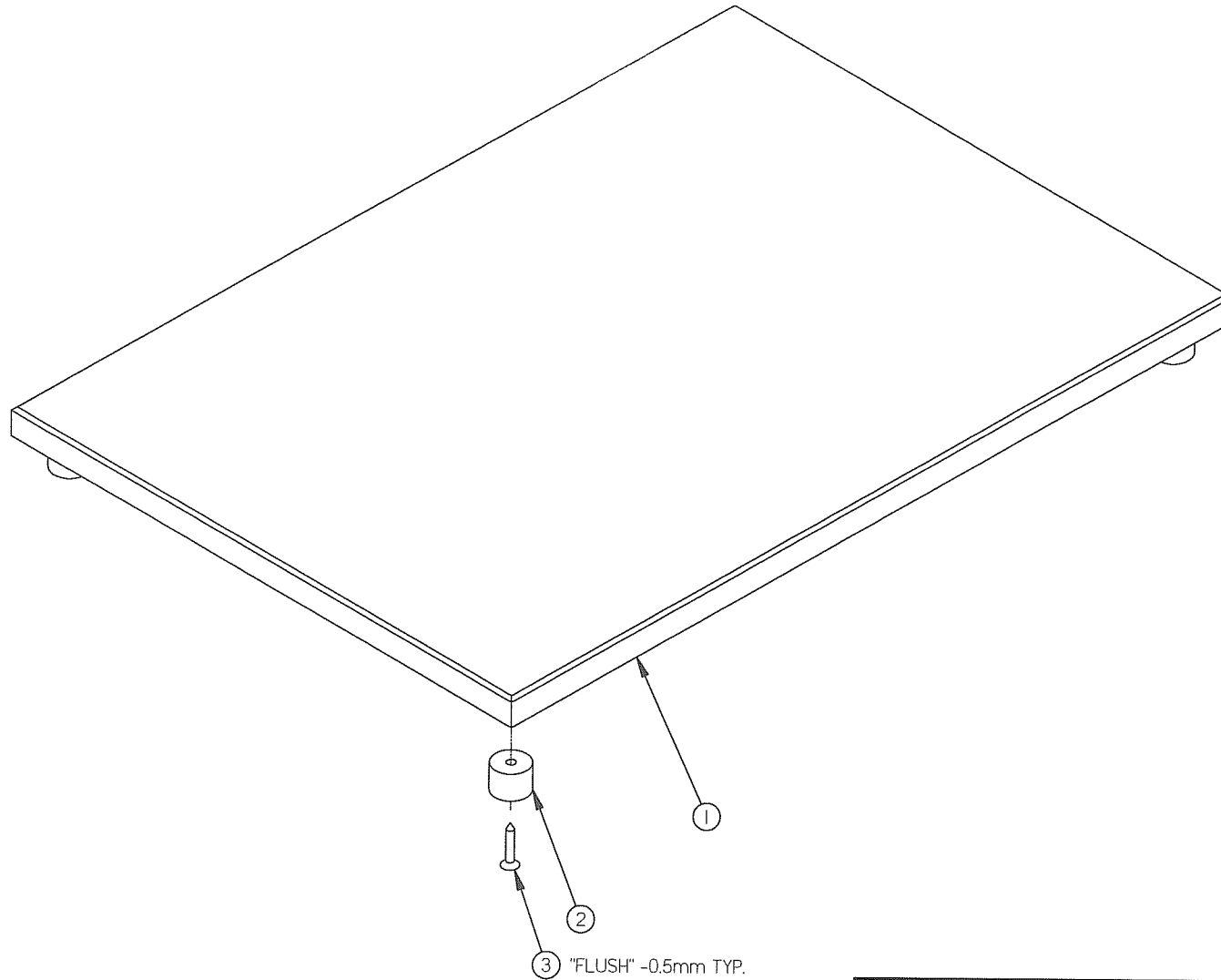

MACHINE	<b>300 &amp; 350</b>		DEPT. TOL.	METRIC	INCH	SIPROMAC ST-GERMAIN DE GRANTHAM QUEBEC CANADA
PART	FILLER PLATE ASS'Y		USUAGE	± 0.1	± 0.004"	
			TOLERIE	± 0.5	± 0.020"	
			SOUDAGE	± 0.5	± 0.020"	N.T.S.
ITEM	CNC	DEPT.	M	QTY.	1	
MAT.	DWG BY	J.G.	DATE	12-10-15	NO.	<b>005A0278</b>
	APP. BY		DATE			

C	REDESSINE MODIF. A-462	12-10-15	J.G.
LET.	MODIFICATION	DATE	INT.

005A0364

ITEM	PART #	DESCRIPTION	QT.
1	008A0337	HALF FILLER PLATE	1
2	003-0080	FILLER PLATE FOOT	4
3	054-0019	METAL SCREW #10x1"FLAT PHIL S/S	4

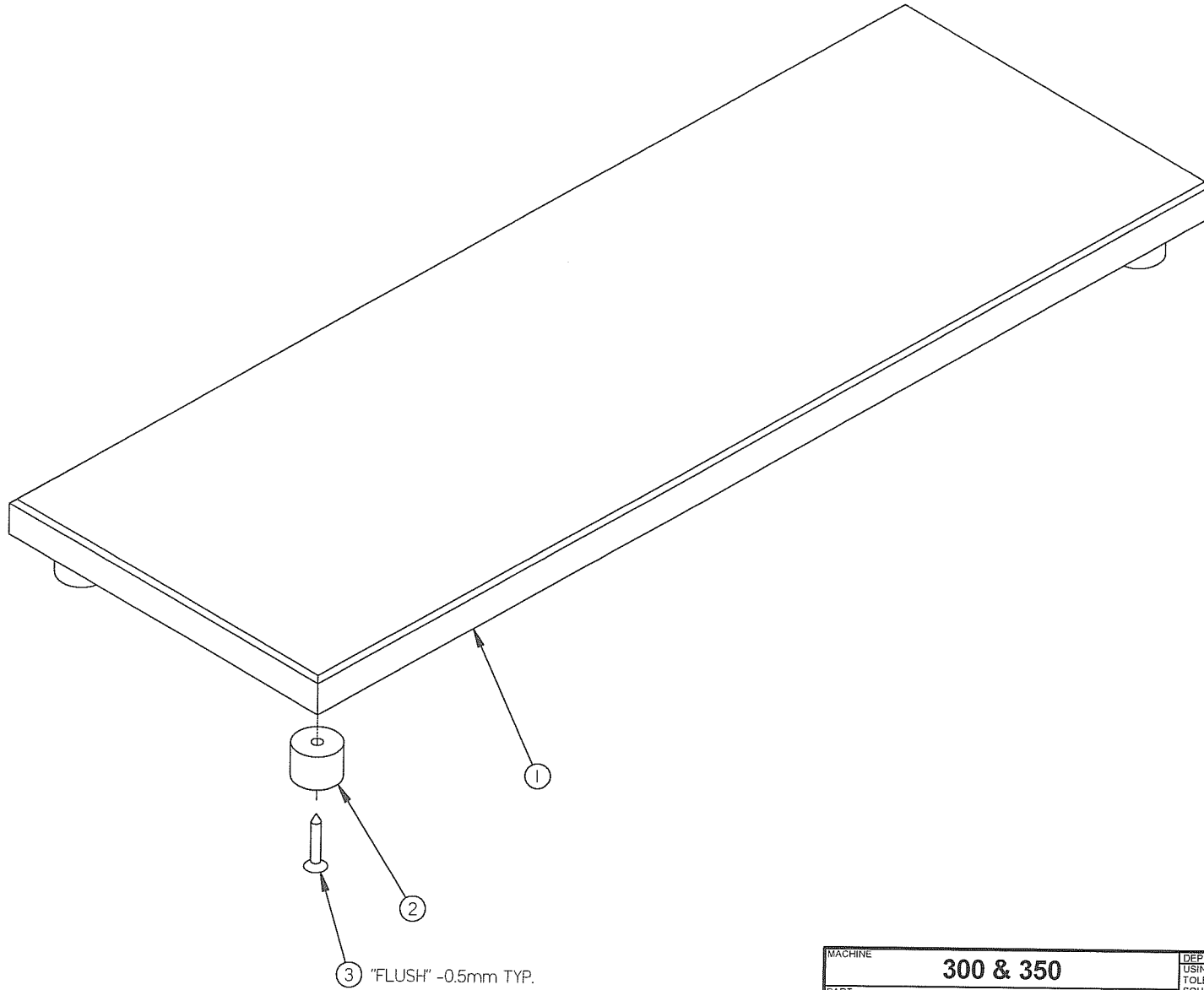

C	REDESSINE MODIF. A-462	12-10-15	J.G.
LET.	MODIFICATION	DATE	INT.

MACHINE	300 & 350		DEPT. TOL.	METRIC	INCH	SIPROMAC ST-GERMAIN DE GRANTHAM QUEBEC CANADA
PART	HALF FILLER PLATE ASS'Y		USINAGE	± 0.1	± 0.004"	
ITEM			TOLERIE	± 0.5	± 0.020"	
MAT.			SOUDEAGE	± 0.5	± 0.020"	N.T.S.
			CNC			DEPT. M
			DWG BY J.G.	DATE 12-10-15	QTY. 2	
			APP. BY	DATE	NO. 005A0364	

005A0365

ITEM	PART #	DESCRIPTION	QT.
1	008A0338	FILLER PLATE	1
2	003-0080	FILLER PLATE FOOT	4
3	054-0019	METAL SCREW #10x1"FLAT PHIL S/S	4

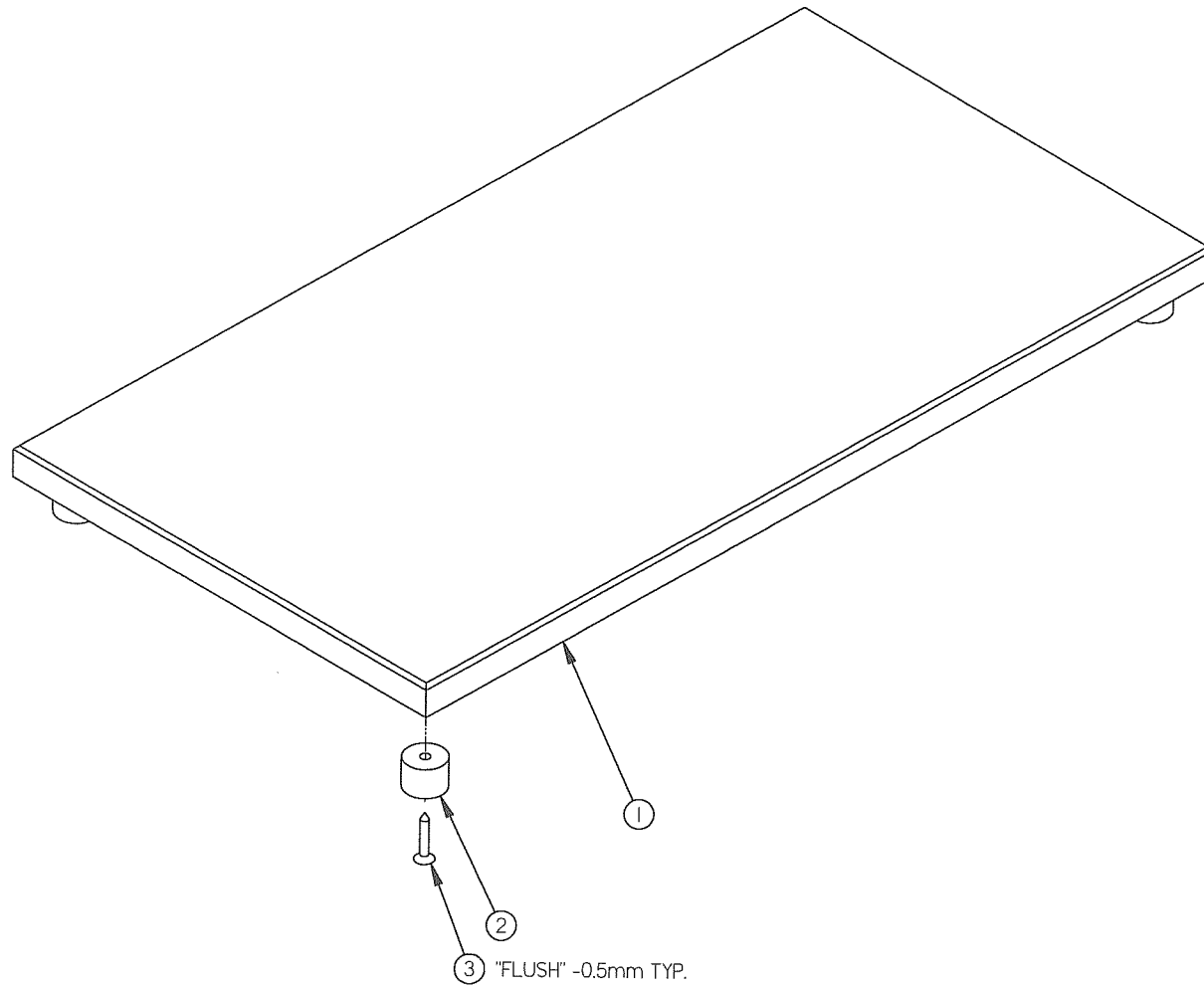

MACHINE	<b>300D &amp; 350D</b>		DEPT. TOL. METRIC	INCH	SIPROMAC ST-GERMAIN DE GRANTHAM QUEBEC CANADA
PART	<b>FILLER PLATE ASS'Y</b>		USINAGE ± 0.1 ± 0.004"	N.T.S.	
			TOLERIE ± 0.5 ± 0.020"		
ITEM	CNC	DEPT.	M	QTY.	2
MAT.	DWG BY <b>J.G.</b>	DATE <b>12-10-15</b>	NO. <b>005A0365</b>		
	APP. BY	DATE			

C	REDESSINE MODIF. A-462	12-10-15	J.G.
LET.	MODIFICATION	DATE	INT.

1005B1031

ITEM	PART #	DESCRIPTION	QT.
1	005B1347	STAND PRE-ASS'Y (SHELF)	1
2	051-0780	WASHER 3/8" FLAT S/S	4
3	051-0410	BOLT 3/8"-nc. X 2.75" S/S	4
4	130-0190	PL. CASTER SWIVEL W/OUT BRAKE	2
5	051-0620	NUT 3/8"-16 NC S/S	4
6	130-0195	PL. CASTER SWIVEL W/BRAKE	2
7	075-0040	BUSHING 3/8" x 1/2" x 5/8" PLAIN	4

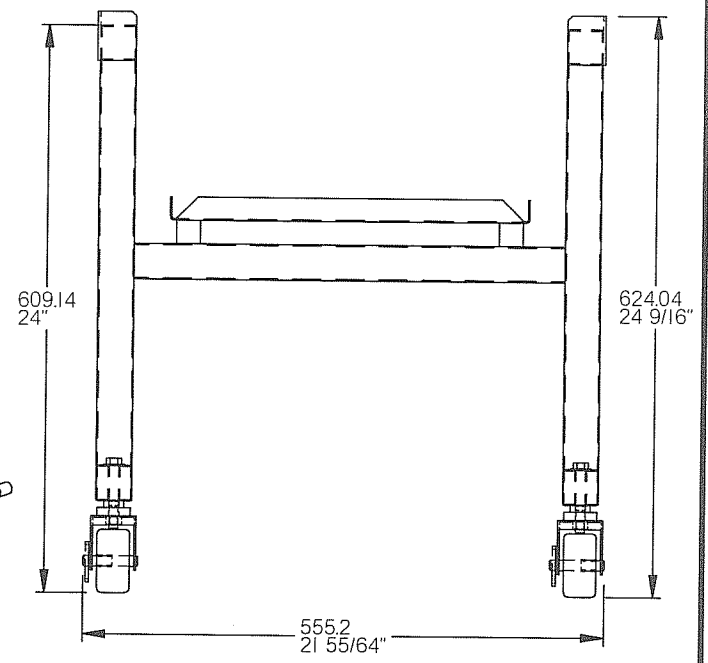
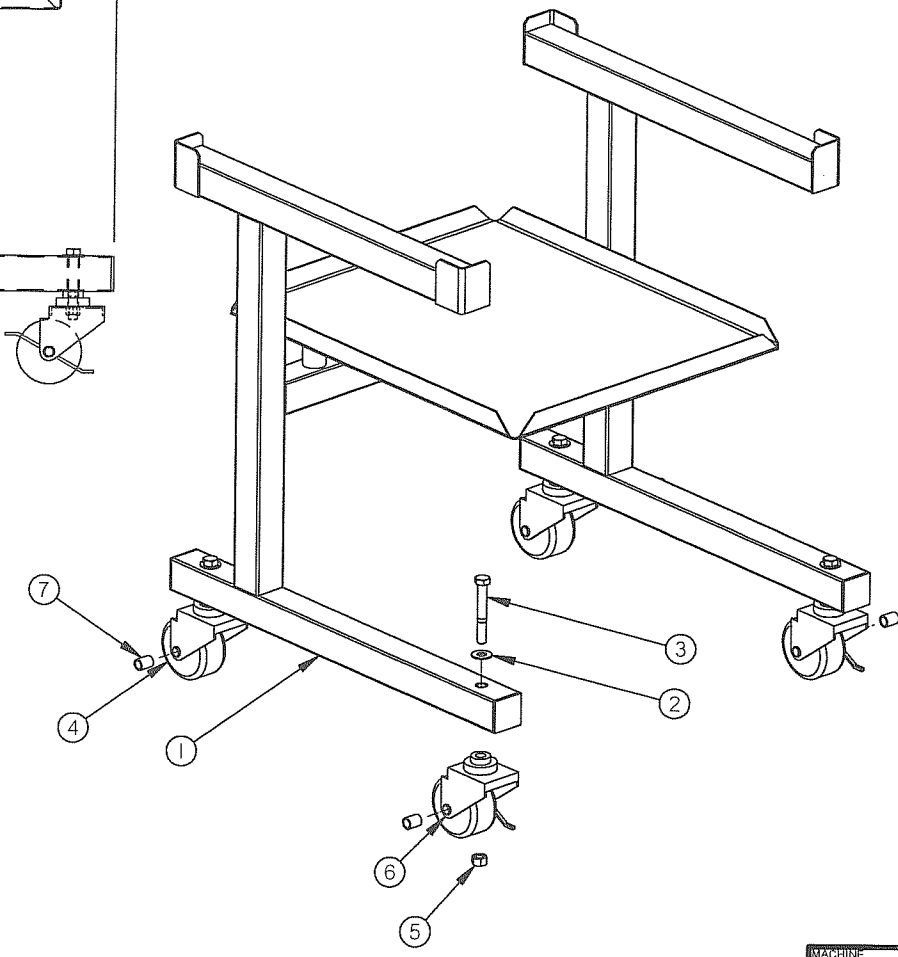
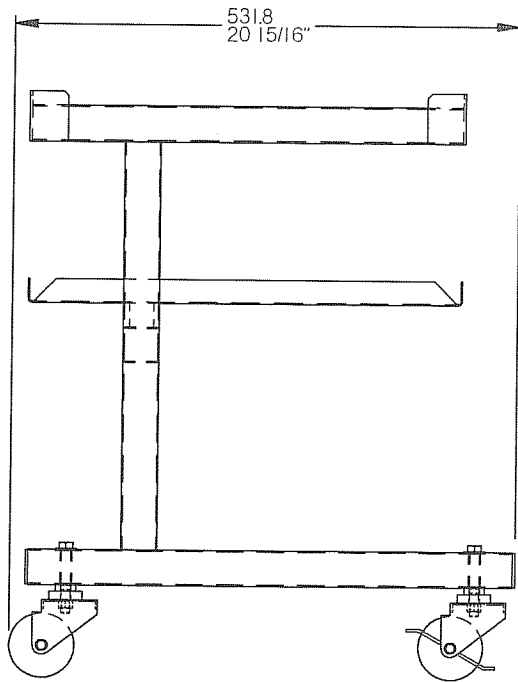

**-STAND OPTION-**

MACHINE	<b>300, 300D, 350 &amp; 350D</b>		DEPT. TOL. METRIC	INCH	SIPROMAC ST-GERMAIN DE GRANTHAM QUEBEC CANADA
PART	<b>STAND ASSEMBLY</b>		USINAGE ± 0.1 ± 0.004"	TOLERIE ± 0.5 ± 0.020"	
			SOUDEGE ± 0.5 ± 0.020"	N.T.S.	
TEM	CNC	DEPT.	M-(1)		QTY. 1
MAT.	DWG BY <b>J.G.</b>	DATE <b>12-10-15</b>	NO. <b>005B1031</b>		
	APP. BY	DATE			

E	REDESSINE MODIF. #A-462	12-10-15	J.G.
LET.	MODIFICATION	DATE	INT.



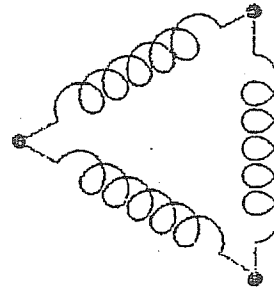
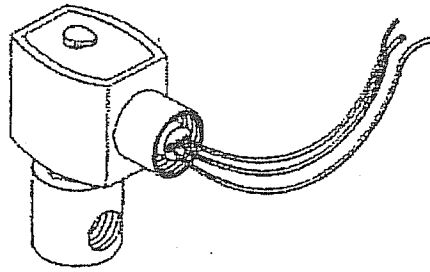
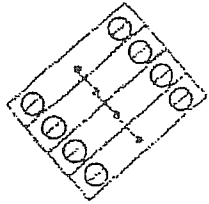

# ELECTRICAL DRAWING

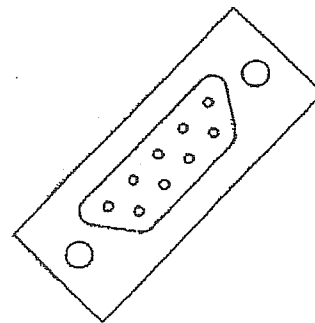
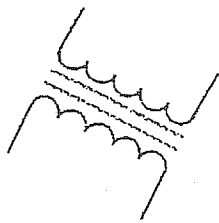

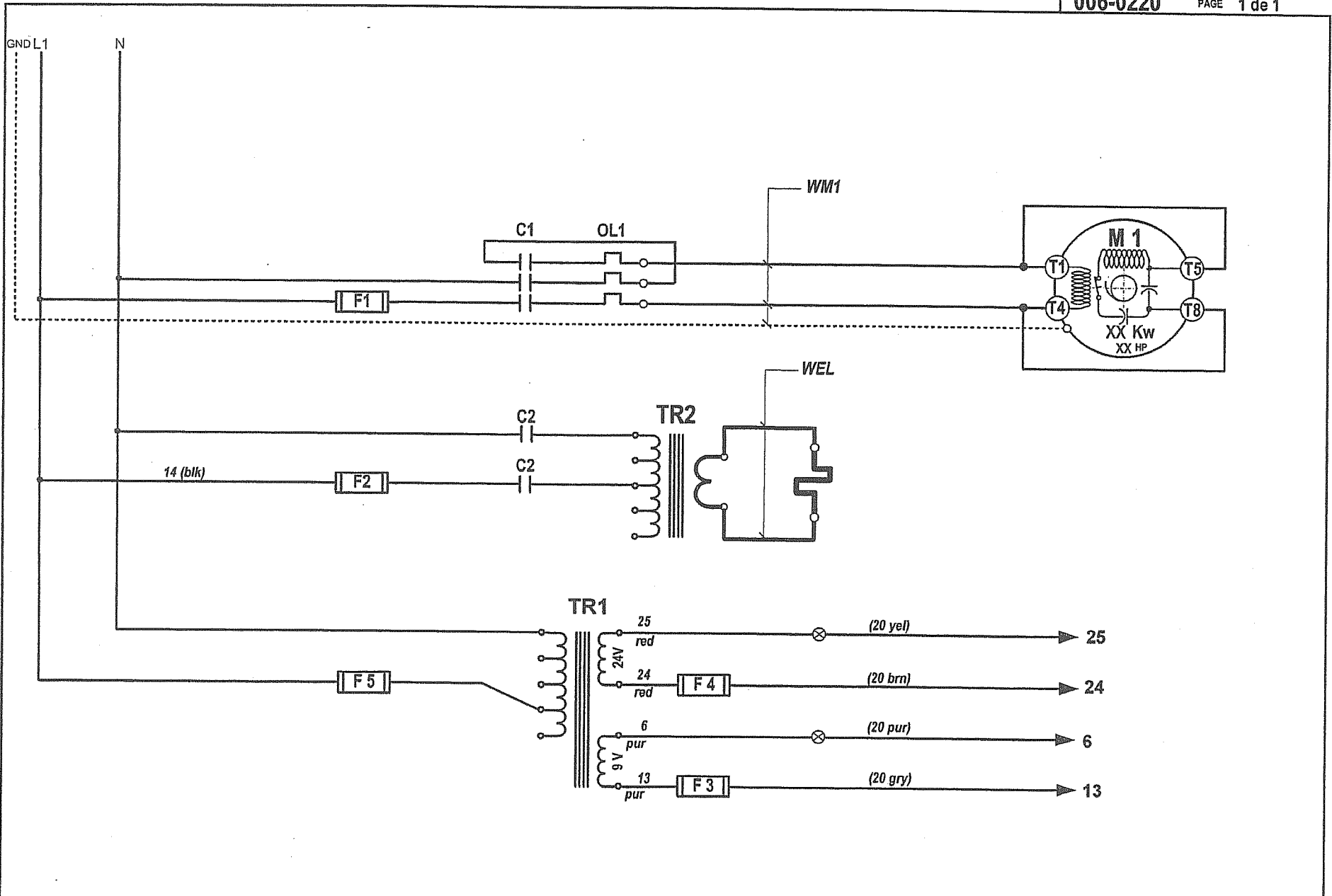

category	VACUUM PACK	model	350	volt.	120V/1PH/60HZ			SIPROMAC St-Germain de Grantham QUEBEC, CANADA
system	MC-40	circuit	power	year	month	day	block	
usual		concept		10	07	08		
fonctions		draw		XX	PP	DL		
options		app		006-0220 PAGE 1 de 1				

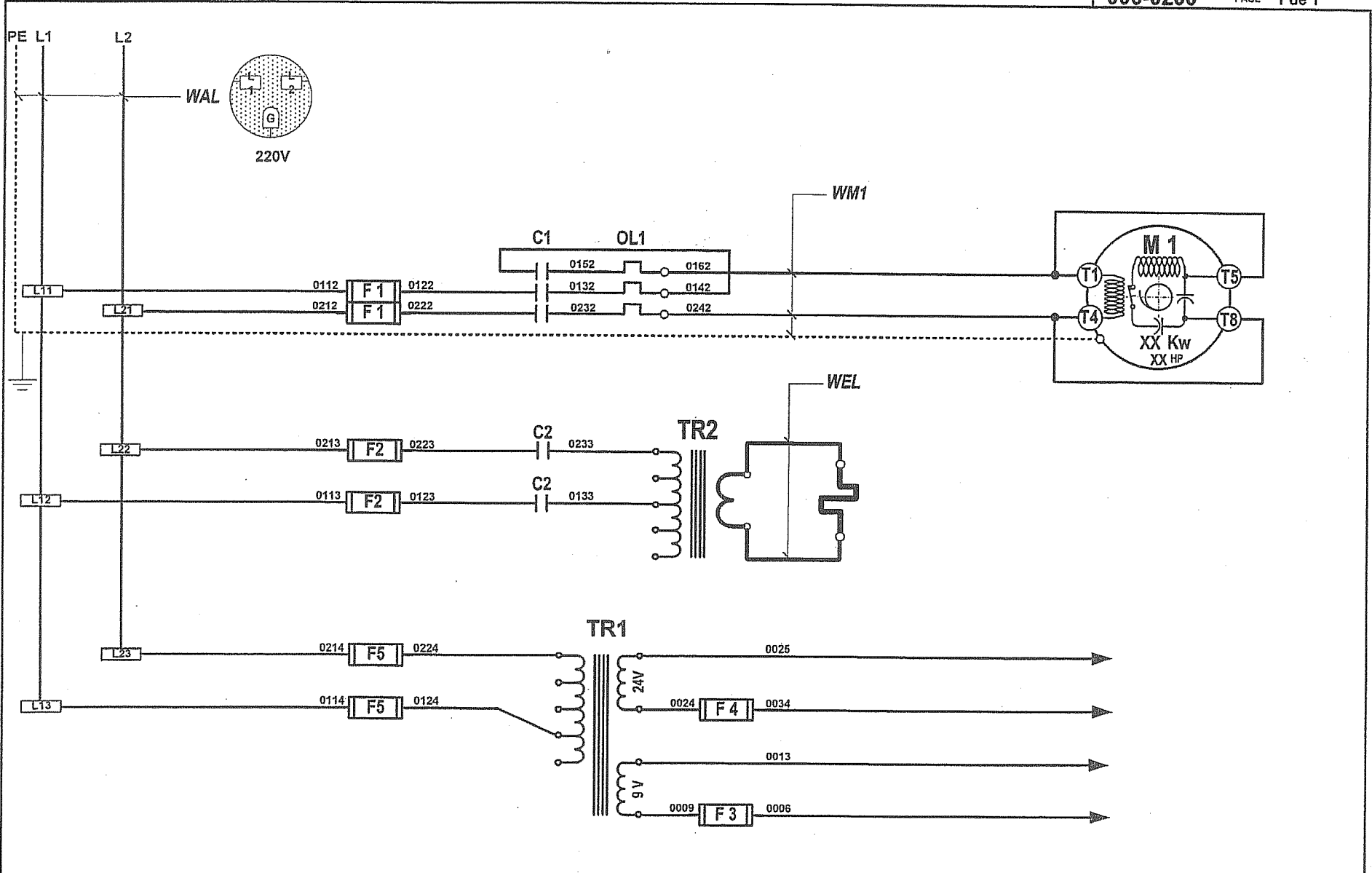

⚠ All unmarked wires are caliber #14 AWG. (006-0200 page 1)

category	VACUUM PACK	model	350	volt.	220V 1Ph 60Hz			SIPROMAC St-Germain de Grantham QUEBEC, CANADA
system	MC-40			circuit	year	month	day	
usual fonctions				power	05	04	25	
options				concept	draw	app	006-0200 PAGE 1 de 1	
				PP	PP	DL		

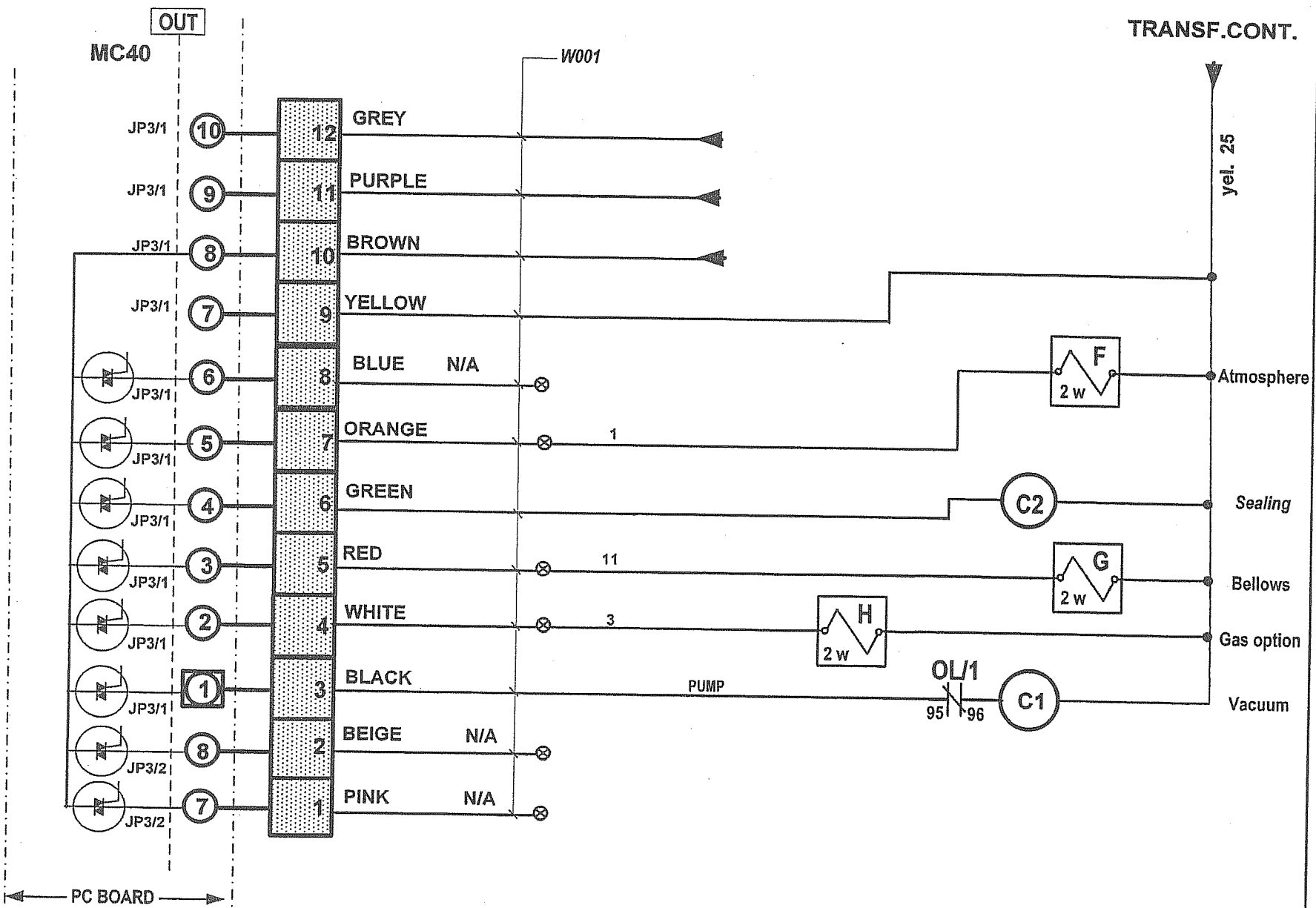

category	<b>VACUUM PACK</b>		model	<b>350</b>		volt	<b>ALL</b>			
system	<b>MC-40</b>				circuit	<b>control</b>			block	
usual fonctions					year	<b>10</b>	month	<b>07</b>	day	<b>08</b>
options					concept	<b>XX</b>	draw	<b>PP</b>	app	<b>DL</b>
					<b>006-0237</b>					
					PAGE 1 de 2					

**SIPROMAC**  
St-Germain de Grantham  
QUEBEC, CANADA

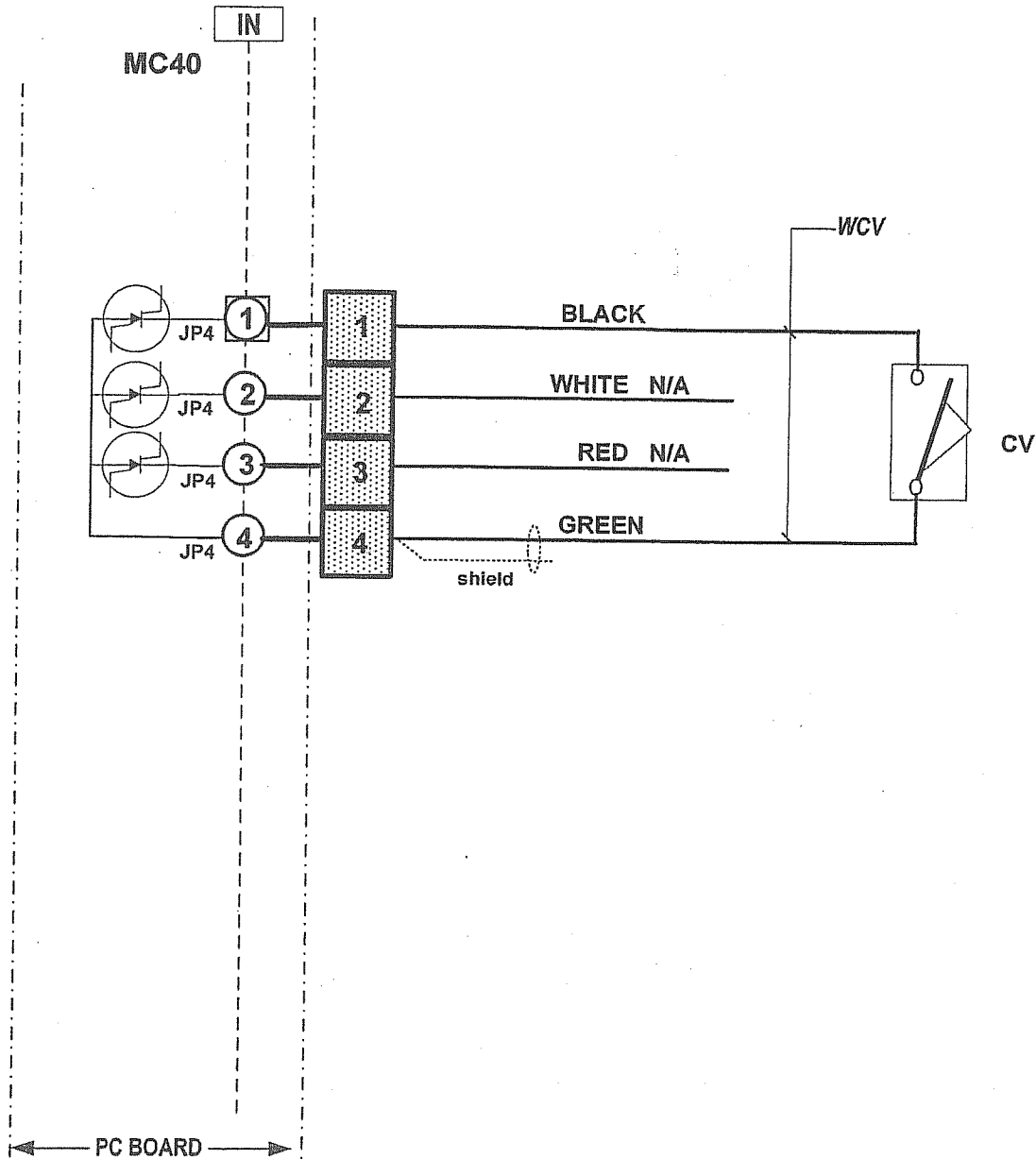

category	<b>VACUUM PACK</b>		model	<b>350</b>	vol.	<b>ALL</b>			<b>SIPROMAC</b> St-Germain de Grantham QUEBEC, CANADA	
system	<b>MC-40</b>				circuit	control	year	month		day
usual							<b>10</b>	<b>07</b>	<b>08</b>	
fonctions							concept	draw	app	
options							<b>XX</b>	<b>PP</b>	<b>DL</b>	<b>006-0237</b> PAGE 2 de 2

# SIPRO	PART DESCRIPTION	PART APPLICATION	MACHINE VOLTAGE	MACHINE	REF.	OPT.	QTY
036-1500	MALE PLUG 15 AMP./ 125 V.	SUPPLY	120V/1PH/60HZ	350	GND-L1-N		1
030-0120	CAB TIRE	SUPPLY	120V/1PH/60HZ	350	GND-L1-N		3 M.
028-0105	GROUND BARRIER (6 HOLES)	SUPPLY	ALL	350	GND		1
034-0755	FUSE HOLDER 30A 1 POLE	VACUUM KB-20	120V/1PH/60HZ	350	F1		1
034-0530	FUSE MIDGET 20A/250V TIME-DELAY	VACUUM KB-20	120V/1PH/60HZ	350	F1		1
025-0030	MOTOR CONTACTOR 1HP IN 120V-CSA,UL	VACUUM KB-20	120V/1PH/60HZ	350	C1		1
025-0190	THERMAL OVERLOAD 12 TO 18A-CSA,UL	VACUUM KB-20	120V/1PH/60HZ	350	O/L1		1
030-0430	TEW #14/41 BLACK	VACUUM KB-20	120V/1PH/60HZ	350	WM1		1M
030-0440	TEW #14/41 GREEN	VACUUM KB-20	120V/1PH/60HZ	350	WM1		0.5M.
125-1020	VACUUM PUMP 110-120V/1PH/60HZ 0.75KW 13A	VACUUM KB-20	120V/1PH/60HZ	350	M1		1
034-0755	FUSE HOLDER 30A 1 POLE	SEALING	120V/1PH/60HZ	350	F2		1
034-0450	FUSE MIDGET 7A/250V TIME-DELAY	SEALING	120V/1PH/60HZ	350	F2		1
025-0020	CONTACTOR 1TH=25A-CSA,UL	SEALING	120V/1PH/60HZ	350	C2		1
029-0014	TRANSFO 250VA, 120V/24V 60HZ	SEALING	120V/1PH/60HZ	350	TR2		1
027-0220	TERMINAL ROUND STUD #10 600v 75°C	SEALING	ALL	350	WEL		2
030-0410	TEW #10/104 BLACK	SEALING	ALL	350	WEL		1.5M.
027-0065	TERMINAL FLAG FEMALE YELLOW .250"	SEALING	ALL	350	WEL		2
005A0046	SEAL BAR ASSEMBLY W/SUPPORT	SEALING TWIN SEAL	ALL	350		A1	1
005A0558	SEAL BAR ASSEMBLY W/SUPPORT	SEALING BAG CUT	ALL	350		A2	1
034-0740	FUSE HOLDER M4/8SF	CONTROL TRANSFO	120V/1PH/60HZ	350	F5		1
034-0200	FUSE 5X20MM 3/4A 250V T-DELAY	CONTROL TRANSFO	120V/1PH/60HZ	350	F5		1
029-0008	TRANSFO 65VA/120V/24-9V	CONTROL TRANSFO	120V/1PH/60HZ	350	TR1		1
034-0740	FUSE HOLDER M4/8SF	CONTROL 9VAC+24VAC	ALL	350	F3+F4		2
034-0210	FUSE 5X20MM 2A/250V TIME DELAY	CONTROL 9VAC	ALL	350	F3		1
034-0240	FUSE 5X20MM 4A/250V TIME DELAY	CONTROL 24VAC	ALL	350	F4		1
030-0590	20AWG/12COND.PVC,UNSHIELD.300V	OUTPUT CONTROL	ALL	350	W001		1M.
036-0740	12 CONTACTS CONNECTOR	OUTPUT CONTROL	ALL	350	JP3/1-2		1
030-0631	22AWG/4COND.PVC,SHIELDED,300V.	INPUT CONTROL	ALL	350	WCV		2M.
036-0820	0.156" CENTERLINE CRIMP HOUSING	INPUT CONTROL	ALL	350	JP4		1
036-0850	0.156" CENTERLINE CRIMP TERMINAL	INPUT CONTROL	ALL	350	JP4		2
033-0038	MICROPROCESSOR MC-40 SENSOR VACUUM	CONTROL WITH SENSOR	ALL	350	MC-40	B1	1
033-00385	MICROPROCESSOR MC-40 NO SENSOR VAC.	CONTROL W/O SENSOR	ALL	350	MC-40	B2	1
033-0015	MEMBRANE MC-40 SIPROMAC	CONTROL SIPROMAC	ALL	350		C1	1
033-0018	MEMBRANE MC-40 BERKEL	CONTROL BERKEL	ALL	350		C2	1
106-0020	VALVE 2WAY 24V 1/2 NPT(G94) 60HZ	ATMOSPHERE	ALL	350	F		1
106-0070	VALVE 3WAY 24V 1/4 NPT(G176)60HZ	BELLOWS	ALL	350	G		1
106-0010	VALVE 2WAY 24V 1/4 NPT(G22) 60HZ	OPTION GAS	ALL	350	H	D	1
004-0261	LIMIT SWITCH ASSY 15A 250V	COVER POSITION	ALL	350	CV		1
036-1512	MALE PLUG 15 AMP./ 250 V.	SUPPLY	220V/1PH/60HZ	350	GND-L1-L2		1
030-0160	CAB TIRE	SUPPLY	220V/1PH/60HZ	350	GND-L1-L2		3 M.

# SIPRO	PART DESCRIPTION	PART APPLICATION	MACHINE VOLTAGE	MACHINE	REF.	OPT.	QTY
028-0105	GROUND BARRIER (6 HOLES)	SUPPLY	ALL	350	GND		1
034-0755	FUSE HOLDER 30A 1 POLE	VACUUM KB-20	220V/1PH/60HZ	350	F1		2
034-0500	FUSE MIDGET 15A/250V TIME-DELAY	VACUUM KB-20	220V/1PH/60HZ	350	F1		2
025-0010	MOTOR CONTACTOR 1HP IN 220V MONO-CSA,UL	VACUUM KB-20	220V/1PH/60HZ	350	C1		1
025-0160	THERMAL OVERLOAD 5.5 TO 8A-CSA,UL	VACUUM KB-20	220V/1PH/60HZ	350	O/L1		1
030-0430	TEW #14/41 BLACK	VACUUM KB-20	220V/1PH/60HZ	350	WM1		1M.
030-0440	TEW #14/41 GREEN	VACUUM KB-20	220V/1PH/60HZ	350	WM1		0.5M.
125-1021	BUSCH KB-0020 220-240V/1PH/60HZ 0.75KW 6.5A	VACUUM KB-20	220V/1PH/60HZ	350	M1		1
034-0755	FUSE HOLDER 30A 1 POLE	SEALING	220V/1PH/60HZ	350	F2		2
034-0445	FUSE MIDGET 5A/250V TIME-DELAY	SEALING	220V/1PH/60HZ	350	F2		2
025-0020	CONTACTOR 17H=25A-CSA,UL	SEALING	220V/1PH/60HZ	350	C2		1
029-0018	TRANSFO 250VA 220V/24V 50/60HZ	SEALING	220V/1PH/60HZ	350	TR2		1
027-0220	TERMINAL ROUND STUD #10 600v 75°C	SEALING	ALL	350	WEL		2
030-0410	TEW #10/104 BLACK	SEALING	ALL	350	WEL		1.5M.
027-0065	TERMINAL FLAG FEMALE YELLOW .250"	SEALING	ALL	350	WEL		2
005A0046	SEAL BAR ASSEMBLY W/SUPPORT	SEALING TWIN SEAL	ALL	350		A1	1
005A0558	SEAL BAR ASSEMBLY W/SUPPORT	SEALING BAG CUT	ALL	350		A2	1
034-0740	FUSE HOLDER M4/8SF	CONTROL TRANSFO	220V/1PH/60HZ	350	F5		2
034-0200	FUSE 5X20MM 3/4A 250V T-DELAY	CONTROL TRANSFO	220V/1PH/60HZ	350	F5		2
029-0007	TRANSFO 65VA/220-230-460V/24-9	CONTROL TRANSFO	220V/1PH/60HZ	350	TR1		1
034-0740	FUSE HOLDER M4/8SF	CONTROL 9VAC+24VAC	ALL	350	F3+F4		2
034-0210	FUSE 5X20MM 2A/250V TIME-DELAY	CONTROL 9VAC	ALL	350	F3		1
034-0240	FUSE 5X20MM 4A/250V TIME-DELAY	CONTROL 24VAC	ALL	350	F4		1
030-0590	20AWG/12COND.PVC,UNSHIELD.300V	OUTPUT CONTROL	ALL	350	W001		1M.
036-0740	12 CONTACTS CONNECTOR	OUTPUT CONTROL	ALL	350	JP3/1-2		1
030-0631	22AWG/4COND.PVC,SHIELDED,300V.	INPUT CONTROL	ALL	350	WCV		2M.
036-0820	0.156" CENTERLINE CRIMP HOUSING	INPUT CONTROL	ALL	350	JP4		1
036-0850	0.156" CENTERLINE CRIMP TERMINAL	INPUT CONTROL	ALL	350	JP4		2
033-0038	MICROPROCESSOR MC-40 SENSOR VACUUM	CONTROL WITH SENSOR	ALL	350	MC-40	B1	1
033-00385	MICROPROCESSOR MC-40 NO SENSOR VAC.	CONTROL W/O SENSOR	ALL	350	MC-40	B2	1
033-0015	MEMBRANE MC-40 SIPROMAC	CONTROL SIPROMAC	ALL	350		C1	1
033-0018	MEMBRANE MC-40 BERKEL	CONTROL BERKEL	ALL	350		C2	1
106-0020	VALVE 2WAY 24V 1/2 NPT(G94) 60HZ	ATMOSPHERE	ALL	350	F		1
106-0070	VALVE 3WAY 24V 1/4 NPT(G176)60HZ	BELLOWS	ALL	350	G		1
106-0010	VALVE 2WAY 24V 1/4 NPT(G22) 60HZ	OPTION GAS	ALL	350	H	D	1
004-0261	LIMIT SWITCH ASSY 16A 250V	COVER POSITION	ALL	350	CV		1

007-0022

-NOTE:  
 -FOR GAS INJECTION  
 KIT INSTALLATION  
 SEE DRAWING #:  
 350: #010-0015  
 350D: #010-0026

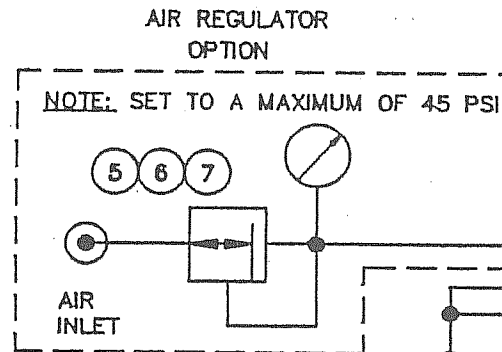
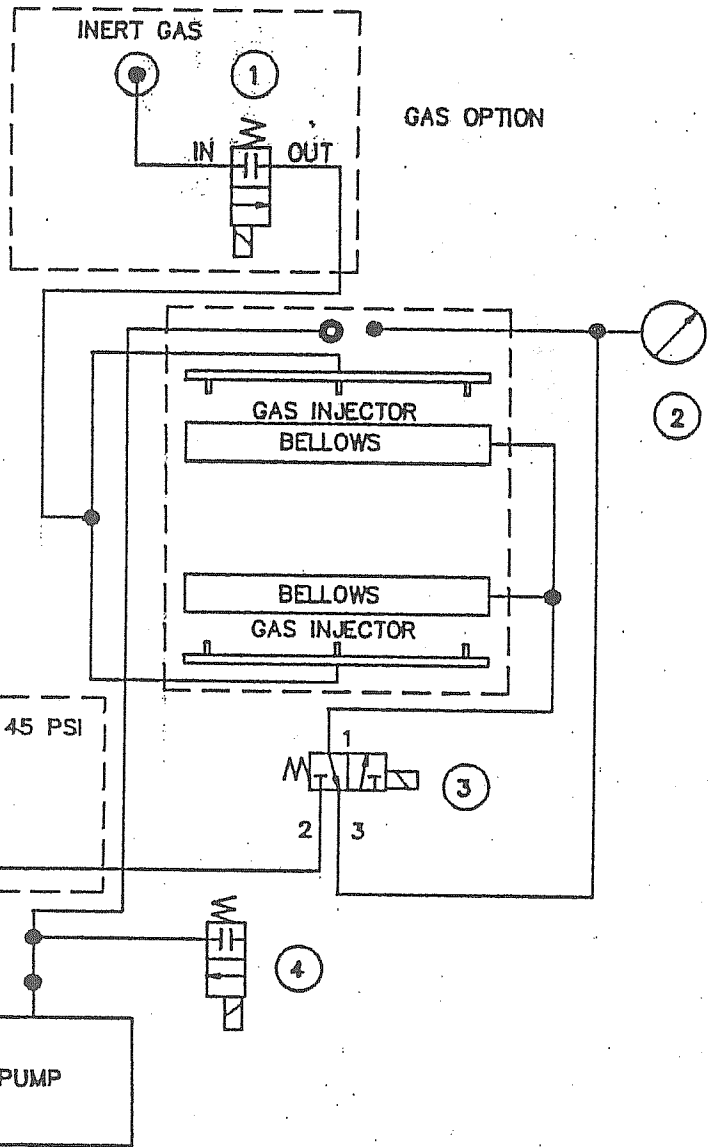

-NOTE:  
 -FOR AIR REGULATOR  
 OPTION KIT INSTALLATION  
 SEE DRAWING #:  
 350 & 350D: 010-0030

ITEM	PART #	DESCRIPTION	QT.
1	106-0010	GAS VALVE	1*
2	114-0260	VACUUM GAUGE	1
3	106-0070	BELLOWS VALVE	1
4	106-0020	ATMOSPHERE VALVE	1
5	114-0147	PRESSURE REGULATOR	1*
6	114-0245	PRESSURE GAUGE	1*
7	114-0170	PRESSURE REGULATOR SUPPORT	1*
* OPTION			

MACHINE	350 & 350D		SIPROMAC	
PART	PNEUMATIC		ST-GERMAIN DE GRANTHAM QUEBEC CANADA	
ITEM:	CNC:	SCALE		QT. 1
MAT:	DRG BY M.LAVIGNE	DATE 97-03-11	NO. 007-0022	
LET.	MODIFICATION	DATE	INT.	

A	RE-DRAWN	97-03-11	M.L.
LET.	MODIFICATION	DATE	INT.

# **MANUEL D'UTILISATEUR**

## **MICROPROCESSEUR MC-40**

### **AVEC OU SANS DÉTECTEUR DE VIDE**

#### **EMBALLEUSE SOUS VIDE**

#### **TABLE DES MATIÈRES**

#### **I INSTRUCTIONS POUR LES OPÉRATIONS**

#### **II MÉCANIQUE**

- A- Vue de face
- B- Vue de l'arrière
- C- Procédure d'ajustement du couvercle
- D- Schéma de l'assemblage de l'axe central
- E- Barres de scellage  
(Double scellage)
- F- Dessin des barres de scellage  
(Option du coupe sac électrique)
- G- Dessins des barres d'assemblage  
(Scellage du haut et du bas en option)
- H- Gas injection kit installation drawing  
(gaz injection option)

#### **III ELECTRIQUE**

- A- Schéma électrique (Bas voltage)
- B- Schéma électrique (Haut voltage à une phase)
- C- Schéma électrique (Haut voltage à 3 phases)
- D- Schéma électrique (Haut voltage 1 phase 50 Hz)
- E- Schéma électrique (Haut voltage 3 phase 50 Hz)

#### **IV PNEUMATIQUE**

- A- Schéma Pneumatique

# EMBALLEUSES SOUS VIDE INSTRUCTIONS D'OPÉRATIONS

## TABLE DES MATIÈRES

1. Mise en marche de la machine
2. Connexion Électrique
3. Opération
  - 3.1 Principes de travail
  - 3.2 Emballage Spécial
    - 3.2.1 Injection de Gaz
    - 3.2.2 Scellage haut et bas  
(bi-active sealing)
    - 3.2.3 Coupe sac électrique
  - 3.3 Ajustement des contrôles digital
  - 3.4 Nettoyage Quotidien
4. Trouble de lancement
  - 4.1 Échec durant le cycle d'emballage
  - 4.2 Vide insuffisant
    - 4.2.1 Fuites dans le sac
    - 4.2.2 Pas de fuite dans le sac
    - 4.2.3 Vide insuffisant dans la chambre
  - 4.3 Scellage Inadéquat
    - 4.3.1 Scellage insuffisant
    - 4.3.2 Pas de scellage
    - 4.3.3 Courant ininterrompu sur les barres de scellage
    - 4.3.4 Le scellage ne tient pas
  - 4.4 Problème avec les valves
  - 4.5 Problème du panneau de contrôle
5. Maintenance Régulière

# SIPROMAC INC. EMBALLEUSES SOUS VIDE

## 1. MISE EN PLACE DE LA MACHINE:

Avant de choisir le site d'installation de votre machine, veuillez considérer que vous aurez besoin d'espace pour les produits emballés et non-emballés à part de l'espace occupé par la machine elle-même.

Bien vouloir vous rappelez que vous aurez besoin d'un sol bien au niveau pour votre installation. Spécialement avec les modèles mobiles, le poids de la pompe peut gauchir la machine et le couvercle ne fermera plus correctement.

Avant de commencer à travailler, vérifier l'huile de la pompe pour voir si elle est en quantité suffisante. Bien vouloir ne jamais utiliser une huile autre que celle recommandée par le fabricant. Ne pas excéder la quantité indiquée quand vous ajoutez ou faites le changement d'huile et faites votre vérification hebdomadairement.

En raison de la viscosité de l'huile, la machine sera plus difficile à démarrer à basses températures. Ainsi donc la pompe doit être placée dans un endroit où la température est d'au moins 50°F (+10°C). D'autre part, l'air doit circuler librement aux alentours de la pompe pour permettre le refroidissement dans les cas où la température des opérations atteindrait 160°F (70°C) ou la température maximale permise.

## 2. CONNEXION ÉLECTRIQUE:

Les connexions électriques doivent se faire par du personnel qualifié. La personne désignée doit s'assurer que les entrées électriques correspondent au voltage et à l'ampérage approprié de la machine.

Un schéma électrique accompagne chacune de nos machines.

Une étape importante dans le branchement de la machine est de s'assurer que le moteur de la pompe tourne dans une rotation appropriée.

Attention: Le moteur de la pompe ne devrait pas tourner plus de 3 ou 4 secondes dans une mauvaise rotation car il en résultera des dommages sérieux. La rotation est indiquée par une flèche sur le moteur de la pompe.

## 3. OPÉRATION:

### 3.1 Principes de travail:

Un emballage sous vide est un cycle composé de 3 étapes. Premièrement le vide est fait et l'air est complètement enlevé de la chambre et du sac contenant le produit. (Voir figure 1). Ensuite c'est possible d'injecter du gaz neutre par les conduits si le produit est très délicat. Finalement, un mécanisme pousse la barre de scellage sur le support de caoutchouc pour sceller le sac

Pour obtenir de beaux emballages, les produits et les sacs doivent être de taille proportionnelles. L'ouverture du sac ne devrait jamais excéder 2" (50cm) au delà des barres de scellage. Le produit doit être centré en hauteur par rapport aux barres de scellage en ajustant les écarteurs qui vous sont fournis.

Pour obtenir un bon scellage, assurez-vous qu'il n'y a pas de résidu de graisse qui reste entre les côtés intérieurs des sacs où le scellage doit être fait.

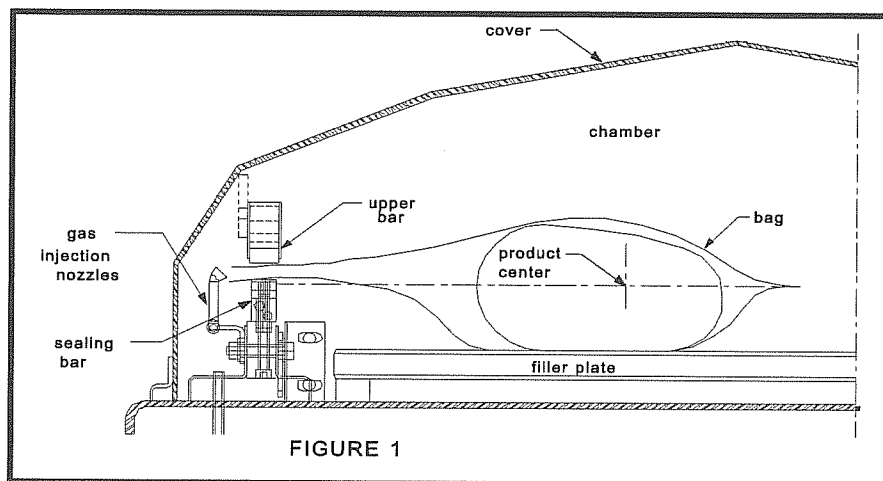

### 3.2 Emballage Spécial:

#### 3.2.1 Injection de Gaz (option):

Il y a une pression atmosphérique de 14 lbs / pouce carré (= 1 kg / cm carré) sur les produits quand le vide demandé est atteint. Les produits qui peuvent être endommagés par une haute pression doivent être emballés avec un vide partiel et la pression doit être contrebalancée en injectant du gaz dans le sac (nitrogène ou dioxyde de carbone) avant le scellement et après avoir atteint le vide.

Pour l'injection de gaz, les sacs sont placés sur les barres de scellage, l'ouverture placée au dessus des conduits de gaz qui sont montés le long des barres de scellage. Après que le vide soit atteint, la valve du vide se ferme et la valve du gaz s'ouvre. Le pourcentage de gaz peut être ajusté par le menu du programme.

Le réservoir de gaz et la valve de pression qui est rattachée au réservoir ne sont pas fournis par Sipromac. La pression pour le régulateur de gaz devrait être ajustée approximativement à 5 lbs/pouce carré (1/3 Kg/cm carré). Chaque machine a un adaptateur pour la connexion de gaz quand l'option de l'injection de gaz est commandée.

#### 3.2.2 Scellage Haut et Bas (optionnel):

Pour le scellage des sacs en aluminium comme pour le café il est impératif d'avoir une barre de scellage en haut et en bas.

#### 3.2.3 Coupe sac électrique: (optionnel):

Cette option est utilisée pour obtenir un paquet dont l'excédent de film au niveau du scellage doit être coupée très près de la ligne de scellage. ( cette option ne peut pas être utilisée avec le scellage Haut et Bas)

### 3.3 Les opérations de l'emballage sous vide:

Note: Reportez-vous aux menus structure de la page 8 et aux détails du panneau de contrôle sur la page 9

#### 3.3.1 Bases:

Utilisez la touche "POWER" pour initier le bouton ON/OFF sur votre machine sous vide. Quand votre unité sera en fonction le dernier programme exécuté apparaîtra sur l'écran à cristaux liquides.

Utilisez la touche "ESC" pour passer du menu programme au menu fonctions et du menu des fonctions au menu des programmes.

Dans le menu des fonctions, utilisez la touche "SELECT" pour sélectionner une fonction et la touche "ENTER" pour exécuter la sélection.

Dans le menu des programmes, utilisez la touche "SELECT" pour sélectionner un programme et la touche "Enter" pour accéder ou modifier la sélection.

Dans les programmes du sous menu, utilisez la touche "ENTER" pour voir défiler les paramètres et lorsque ces derniers clignotent pour indiquer ils sont dans le mode d'acquisition. Quand la séquence de tous les paramètres se sont affichés, on revient automatiquement au début de la liste.

Dans les programmes du sous menu, utilisez la touche "ESC" pour revenir au menu des programmes. Pressez n'importe quelle touche pour effacer les messages d'erreur qui peuvent s'afficher sur l'écran à cristaux liquide.

#### 3.3.2 Menu des fonctions:

##### 3.3.2.1 Créer un programme:

Quand vous exécutez la fonction "create a program", le programme sous menu est atteint en commençant par l'identification. L'identification initiale "PxxNO NAME" est donné au programme et tous les paramètres sont établis à zéro; le numéro du programme est alloué automatiquement.

##### 3.3.2.2 Supprimer un programme:

En exécutant la fonction de "delete a program", vous avez accès au menu des programmes et le numéro du premier programme en mémoire clignote pour indiquer le mode de suppression. Utilisez la touche "SELECT" pour sélectionner un programme et la touche "ENTER" pour avoir accès et confirmer la suppression de la sélection. Utilisez la touche "ESC" pour annuler une suppression et quitter la fonction. Quand vous quittez la fonction, le nombre des programmes actuels sur l'écran à cristaux liquides cesse de clignoter.

##### 3.3.2.3 Choisir le mode d'opération:

Quand vous exécutez la fonction "Select Operating Mode", laquelle est disponible seulement pour les unités automatiques, la sélection en cours clignote pour vous indiquez le mode. Utilisez la touche "SELECT" pour parcourir les modes d'opération, lesquels sont automatiques, semi-automatiques et manuels.

Le mode d'opération sera validé et exécuté automatiquement. Utilisez la touche "ESC" ou "ENTER" pour quitter la fonction et retourner au menu des programmes.

### 3.3.3 Menu des Programmes:

#### 3.3.3.1 Identification des Programmes:

Pour un programme sélectionné, choisissez l'identification en utilisant le panneau de contrôle numérique avec la chartre des caractères et pressez sur la touche numérique jusqu'à ce que le caractère soit sélectionné (4 x pour la valeur numérique). Utilisez la touche "ENTER" pour valider le caractère ainsi que la chaîne de caractères jusqu'à la fin ( la nouvelle chaîne de caractères clignote). Vous pouvez utiliser la touche "ESC" pour revenir en arrière dans le cas où vous vous êtes trompé et que vous voulez effacer le caractère.

Exemple: EXAMPLE 1 → Touche 2, 2, ENTER → E  
(9 caractères) Touche 8, 8, 8, ENTER → X  
Touche 1, ENTER → A  
Touche 5, ENTER → M  
Touche 6, ENTER → P  
Touche 4, 4, 4, ENTER → L  
Touche 2, 2, ENTER → E  
Touche 9, 9, 9, ENTER → espace  
Touche 1, 1, 1, 1, ENTER → 1  
Touche ENTER pour valider la chaîne de caractères

#### 3.3.3.2 L'ajustement du niveau de Vide (capteur de vide désactivé):

Pour un programme sélectionné, ajustez le niveau de vide, en secondes; la validation est automatiquement exécutée après la deuxième entrée digitale ( Le nouveau temps de vide clignote). En cours de traitement, utilisez la touche "ENTER" pour valider la valeur du niveau de vide et la touche "ESC" pour revenir en arrière et changer la valeur du niveau de vide ( La valeur du niveau de vide la plus ancienne clignotera à ce moment).

Exemples: 1 sec. → Touches 0, 1 ou 1, ENTER  
15 sec. → Touches 1, 5

#### 3.3.3.3 L'ajustement du niveau de Vide (capteur de vide en activé):

Pour un programme sélectionné, ajustez le niveau de vide avec les valeurs; le point décimal est automatiquement inséré suivant la deuxième entrée digitale et la validation est automatiquement exécutée après la troisième entrée digitale ( La nouvelle valeur du niveau du vide clignote). Le niveau de vide est arrondi à la demie la plus près de la valeur. En cours de traitement, utilisez la touche "ENTER" pour valider la valeur du niveau de vide et la touche "ESC" pour revenir en arrière et changer la valeur du niveau de vide ( La valeur du niveau de vide la plus ancienne clignotera à ce moment). Ajustez le niveau du vide à zéro pour pouvoir contourner le capteur de vide et procédez en réglant seulement le " Temps de vide Plus" (Vacuum plus time).

Exemples: 90.0% → Touches 9, 0, 0 ou 9, 0, ENTER ou  
Touches 9, 0, 1 ou 9, 0, 2 or 9, 0, 3 ou 9, 0, 4  
97.5% → Touches 9, 7, 5 ou  
Touches 9, 7, 6 ou 9, 0, 7 or 9, 0, 8 ou 9, 0, 9  
0.0% → Touches 0, 0, 0 ou 0, ENTER

#### 3.3.3.4 Ajustement du Temps de Vide "Plus" (capteur de vide activé):

Pour un programme sélectionné, réglez le "temps de vide plus" en secondes; la validation est automatiquement exécutée après la deuxième entrée digitale ( La nouvelle valeur du "temps de vide plus" clignotera à ce moment). En cours de traitement, utilisez la touche "ENTER" pour valider la nouvelle valeur du "temps de vide plus" et la touche "ESC" pour revenir et recommencer avec de nouvelles valeurs ( la valeur la plus ancienne du "temps de vacuum plus" clignotera).

Exemples: 1s → Touche 0, 1 or 1, ENTER  
15s → Touche 1, 5

#### 3.3.3.5 Ajustement de l'injection de gaz (capteur de vide désactivé):

Pour sélectionner un programme placer le niveau d'injection de gaz en suivant la même procédure que pour le niveau de vide. Gardez en mémoire que plus le temps d'injection de gaz est haut, moins la pression du sellage sera forte. Un certain niveau de vide doit être maintenu pour un bon fonctionnement.

#### 3.3.3.6 Ajustement de l'injection de gaz (capteur de vide activé):

Pour sélectionner un programme placer le niveau d'injection de gaz en suivant la même procédure que pour le niveau de vide; L'ajustement pour le gaz le plus haut devrait être de 10% au-dessous du niveau de l'ajustement de vide.

#### 3.3.3.7 Ajustement du cachetage:

Pour sélectionner un programme le temps de cachetage, en commençant par les secondes; le point décimale est automatiquement insérée après la première entrée de chiffre et la validation est automatiquement effectuée après la troisième entrée de chiffre (le nouveau temps de cachetage clignote). Le temps de cachetage est arrondi à la moitié la plus proche du cent. À un milieu l'entrée des données, utiliser la clé "ENTER" pour valider l'heure du cachetage et la clé " ESC " pour revenir en arrière et reprogrammer le temps cachetage avec de nouvelles données (le vieux temps de cachetage clignote).

Exemples: 4.50s → clés 4, 5, 0 or 4, 5, ENTER or  
clés 4, 5, 1 or 4, 5, 2 or 4, 5, 3 or 4, 5, 4  
2.35s → clés 2, 3, 5 or  
clés 2, 3, 6 or 2, 3, 7 or 2, 3, 8 or 2, 3, 9  
0.00s → clés 0, 0, 0 or 0, ENTER

### 3.3.4 Exécution de cycle de vide :

Pour les unités manuels ainsi que les unités automatiques faire la mise en marche manuelle, fermer le couvercle afin de lancer un cycle de vide. Pour l'unité automatique faire mise en marche semi-automatique ou automatique, utilisez le bouton "ARRÊT / DÉBUT" pour lancer ou interrompre un cycle de vide. Le programme sélectionné peut être lancé seulement dans le programme du menu, au moment où aucune modification n'est nécessaire, et l'accès des autres programmes et des fonctions ne sont pas requis. Pendant l'exécution du cycle le statut d'opération est séquentiellement affiché sur l'écran à cristaux liquides, excepté pour les paramètres établis à zéro, qui ne sont pas montrés:

- niveau de vide de la chambre pendant la séquence,
- vide additionné du temps pendant le vide plus la séquence,
- niveau de vide de la chambre pendant la séquence d'injection de gaz,
- statut de temps de cachetage pendant la séquence de cachetage,
- niveau de vide de la chambre pendant La séquence d'atmosphère .7

Pendant l'exécution du cycle, utilisé la clef "1" pour interrompre la séquence de vide et pour exécuter la séquence suivante, soit l'injection du gaz ou le cachetage, suivi de la clé "ENTER" afin d'accéder et modifier le programme; les paramètres deviennent valides seulement pour les cycles suivants de vide.

### 3.3.5 System monitor:

Pour accéder le menu des diagnostics, monter la puissance de la machine d'emballage sous vide tout en maintenant le bouton "ESC" enfoncé. Utilisez la clé "SELECT" pour choisir la fonction du système du moniteur et "ENTER" pour accéder et visualiser les paramètres surveillés. Employez la clé "SELECT" pour changer la révision de logiciel, la quantité d'heures de travail faites et de la quantité de cycles complets exécutés depuis la première initialisation.

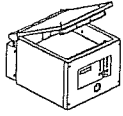

250

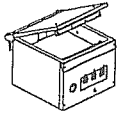

300

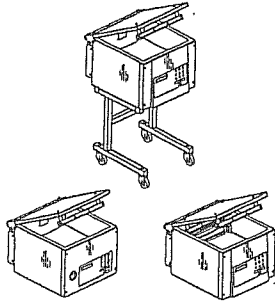

350/350D

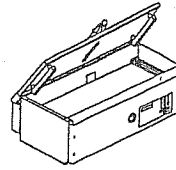

380A

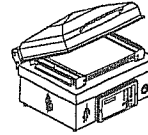

450T

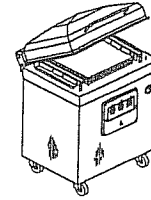

400A

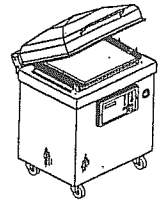

450A

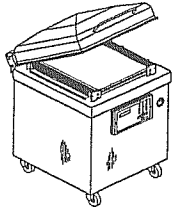

550A

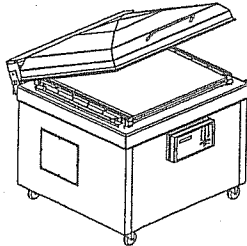

580A

VACUUM PACKAGING MACHINES

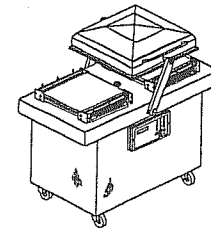

420A

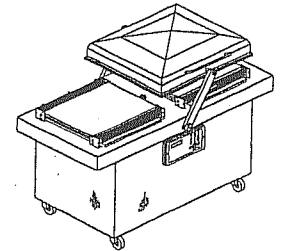

600A

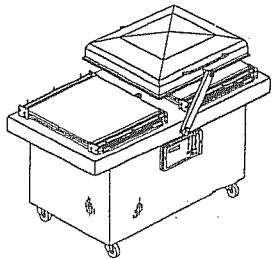

620A

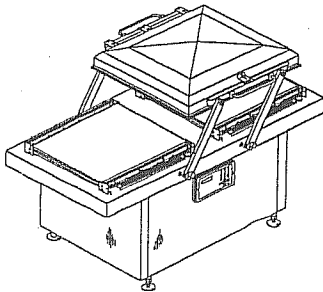

650A

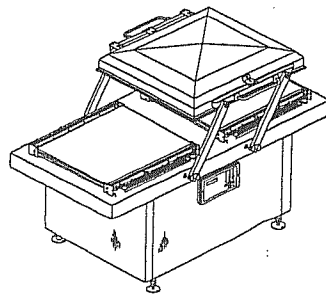

680A

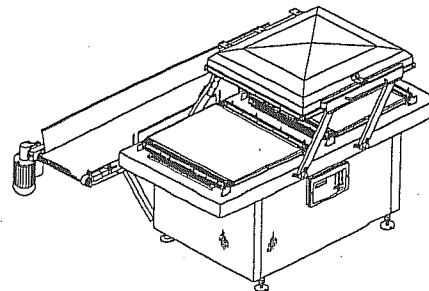

700A

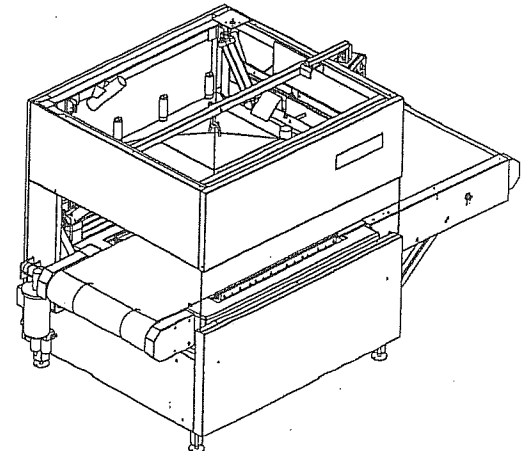

750A