

SHARP SERVICE MANUAL

S8019R1750X//

OVER THE RANGE MICROWAVE OVEN

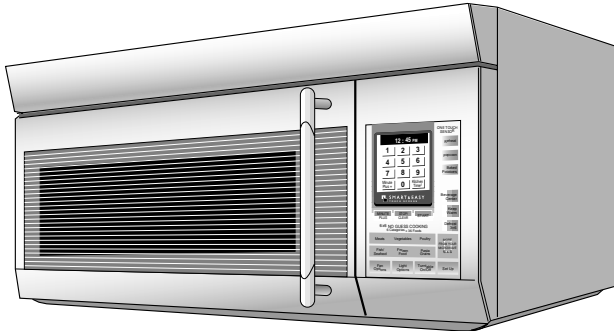

MODELS **R-1750**
 R-1751
 R-1752
 R-1754

In the interest of user-safety the oven should be restored to its original condition and only parts identical to those specified should be used.

WARNING TO SERVICE PERSONNEL: Microwave ovens contain circuitry capable of producing very high voltage and current. Contact with the following parts may result in a severe, possibly fatal, electrical shock. (Inverter unit that includes High Voltage Capacitor, High Voltage Power Transformer, High Voltage Rectifier and Heat sink etc., and Magnetron, High Voltage Harness etc..)

TABLE OF CONTENTS

	Page
PRECAUTIONS TO BE OBSERVED BEFORE AND DURING SERVICING TO AVOID POSSIBLE EXPOSURE TO EXCESSIVE MICROWAVE ENERGY	INSIDE FRONT COVER
BEFORE SERVICING	INSIDE FRONT COVER
WARNING TO SERVICE PERSONNEL	1
MICROWAVE MEASUREMENT PROCEDURE	2
FOREWORD AND WARNING	3
PRODUCT SPECIFICATIONS	4
GENERAL INFORMATION	4
OPERATION	6
TROUBLESHOOTING GUIDE	14
TEST PROCEDURE	16
TOUCH CONTROL PANEL ASSEMBLY	27
COMPONENT REPLACEMENT AND ADJUSTMENT PROCEDURE	33
PICTORIAL DIAGRAM	41
POWER UNIT CIRCUIT	42
LSI UNIT CIRCUIT	43
PRINTED WIRING BOARD	44
PARTS LIST	45
PACKING AND ACCESSORIES	50

SHARP CORPORATION

This document has been published to be used for after sales service only.

The contents are subject to change without notice.

PRECAUTIONS TO BE OBSERVED BEFORE AND DURING SERVICING TO AVOID POSSIBLE EXPOSURE TO EXCESSIVE MICROWAVE ENERGY

- (a) Do not operate or allow the oven to be operated with the door open.
- (b) Make the following safety checks on all ovens to be serviced before activating the magnetron or other microwave source, and make repairs as necessary: (1) interlock operation, (2) proper door closing, (3) seal and sealing surfaces (arcing, wear, and other damage), (4) damage to or loosening of hinges and latches, (5) evidence of dropping or abuse.
- (c) Before turning on microwave power for any service test or inspection within the microwave generating compartments, check the magnetron, wave guide or transmission line, and cavity for proper alignment, integrity, and connections.
- (d) Any defective or misadjusted components in the interlock, monitor, door seal, and microwave generation and transmission systems shall be repaired, replaced, or adjusted by procedures described in this manual before the oven is released to the owner.
- (e) A microwave leakage check to verify compliance with the Federal Performance Standard should be performed on each oven prior to release to the owner.

BEFORE SERVICING

Before servicing an operative unit, perform a microwave emission check as per the Microwave Measurement Procedure outlined in this service manual.

If microwave emissions level is in excess of the specified limit, contact SHARP ELECTRONICS CORPORATION immediately @1-800-237-4277.

If the unit operates with the door open, service person should 1) tell the user not to operate the oven and 2) contact SHARP ELECTRONICS CORPORATION and Food and Drug Administration's Center for Devices and Radiological Health immediately.

Service personnel should inform SHARP ELECTRONICS CORPORATION of any certified unit found with emissions in excess of $4\text{mW}/\text{cm}^2$. The owner of the unit should be instructed not to use the unit until the oven has been brought into compliance.

DANGER CAUTION HIGH VOLTAGE

Do not energize a microwave oven with the outer case cabinet removed, because a microwave oven generates High Voltage in the circuit.

If you intend to operate the oven employing the high frequency switching power converter circuit, you should take special precautions to avoid an electrical shock hazard.

The high voltage transformer, high voltage capacitor and high voltage diode have energized high voltage potential approx. 8 KV.

The aluminium heat sink is connected to the switching power transistor Collector pole, and has an energized high voltage potential approx. 650V peak.

DO NOT ACCESS THE HIGH VOLTAGE TRANSFORMER, HIGH VOLTAGE CAPACITOR, HIGH VOLTAGE DIODE AND HEAT SINK WHEN THE POWER SUPPLY IS CONNECTED TO AN ELECTRICAL OUTLET.

WARNING TO SERVICE PERSONNEL

Microwave ovens contain circuitry capable of producing very high voltage and current, contact with following parts may result in a severe, possibly fatal, electrical shock.

(Example)

Inverter unit that includes High Voltage Capacitor, High Voltage Power Transformer, High Voltage Rectifier, Heat sink etc., and Magnetron, High Voltage Harness etc..

Read the Service Manual carefully and follow all instructions.

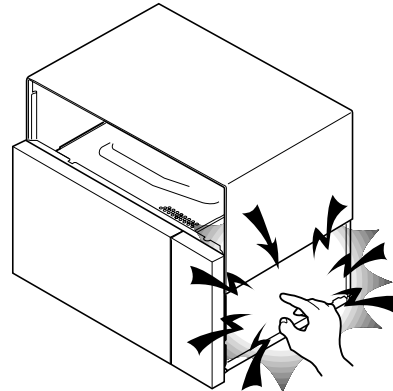

**Don't Touch !
Danger High Voltage**

Before Servicing

1. Disconnect the power supply cord  , and then remove outer case.
2. Open the door and block it open.
3. To discharge high voltage capacitor, wait for 60 seconds.

**WARNING: RISK OF ELECTRIC SHOCK.
DISCHARGE THE HIGH-VOLTAGE
CAPACITOR BEFORE SERVICING.**

The high-voltage capacitor remains charged about 60 seconds after the oven has been switched off. Wait for 60 seconds and then short-circuit the connection of the high-voltage capacitor (that is the connecting lead of the high-voltage rectifier) against the chassis with the use of an insulated screwdriver.

Whenever troubleshooting is performed the power supply must be disconnected. It may in, some cases, be necessary to connect the power supply after the outer case has been removed, in this event,

1. Disconnect the power supply cord, and then remove outer case.
2. Open the door and block it open.
3. To discharge high voltage capacitor, wait for 60 seconds.
4. Disconnect the leads to the primary of the inverter unit.
5. Ensure that these leads remain isolated from other components and oven chassis by using insulation tape.
6. After that procedure, reconnect the power supply cord.

When the testing is completed,

1. Disconnect the power supply cord, and then remove outer case.
2. Open the door and block it open.
3. To discharge high voltage capacitor, wait for 60 seconds.
4. Reconnect the leads to the primary of the inverter unit.
5. Reinstall the outer case (cabinet).
6. Reconnect the power supply cord after the outer case is installed.
7. Run the oven and check all functions.

After repairing

1. Reconnect all leads removed from components during testing.
2. Reinstall the outer case (cabinet).
3. Reconnect the power supply cord after the outer case is installed.
4. Run the oven and check all functions.

Microwave ovens should not be run empty. To test for the presence of microwave energy within a cavity, place a cup of cold water on the oven turntable, close the door and set the power to HIGH and set the microwave timer for two (2) minutes. When the two minutes has elapsed (timer at zero) carefully check that the water is now hot. If the water remains cold carry out **Before Servicing** procedure and re-examine the connections to the component being tested.

When all service work is completed and the oven is fully assembled, the microwave power output should be checked and microwave leakage test should be carried out.

SERVICING FOR INVERTER UNIT

WARNING

This inverter unit contains circuitry capable of producing high voltage and high current. Contact with any part of the high voltage will result in electrocution.

**DO NOT ACCESS ANY PARTS OF INVERTER UNIT WITH POWER SUPPLY CONNECTED.
DO NOT OPERATE INVERTER UNIT ITSELF.**

It is dangerous because this unit contains high voltage components.

MICROWAVE MEASUREMENT PROCEDURE

A. Requirements:

- 1) Microwave leakage limit (Power density limit): The power density of microwave radiation emitted by a microwave oven should not exceed 1 mW/cm^2 at any point 5cm or more from the external surface of the oven, measured prior to acquisition by a purchaser, and thereafter (through the useful life of the oven), 5 mW/cm^2 at any point 5cm or more from the external surface of the oven.
- 2) Safety interlock switches Primary interlock relay and door sensing switch shall prevent microwave radiation emission in excess of the requirement as above mentioned, secondary interlock switch shall prevent microwave radiation emission in excess of 5 mW/cm^2 at any point 5cm or more from the external surface of the oven.

B. Preparation for testing:

Before beginning the actual measurement of leakage, proceed as follows:

- 1) Make sure that the actual instrument is operating normally as specified in its instruction booklet.

Important:

Survey instruments that comply with the requirement for instrumentation as prescribed by the performance standard for microwave ovens, 21 CFR 1030.10(c)(3)(i), must be used for testing.

- 2) Place the oven tray in the oven cavity.
- 3) Place the load of $275\pm 15\text{ ml}$ (9.8 oz) of tap water initially at $20\pm 5^\circ\text{C}$ (68°F) in the center of the oven cavity. The water container shall be a low form of 600 ml (20 oz) beaker with an inside diameter of approx. 8.5 cm (3-1/2 in.) and made of an electrically nonconductive material such as glass or plastic. The placing of this standard load in the oven is important not only to protect the oven, but also to insure that any leakage is measured accurately.
- 4) Set the cooking control on Full Power Cooking Mode
- 5) Close the door and select a cook cycle of several minutes. If the water begins to boil before the survey is completed, replace it with 275 ml of cool water.

C. Leakage test:

Closed-door leakage test (microwave measurement)

- 1) Grasp the probe of the survey instrument and hold it perpendicular to the gap between the door and the body of the oven.
- 2) Move the probe slowly, not faster than 1 in./sec. (2.5 cm/sec.) along the gap, watching for the maximum indication on the meter.
- 3) Check for leakage at the door screen, sheet metal seams and other accessible positions where the continuity of the metal has been breached (eg., around the switches, indicator, and vents). While testing for leakage around the door pull the door away from the front of the oven as far as is permitted by the closed latch assembly.
- 4) Measure carefully at the point of highest leakage and make sure that the highest leakage is no greater than 4 mW/cm^2 , and that the secondary interlock switch does turn the oven OFF before any door movement.

NOTE: After servicing, record data on service invoice and microwave leakage report.

SERVICE MANUAL

SHARP

OVER THE RANGE
MICROWAVE OVEN

R-1750 / R-1751 / R-1752 / R-1754

FOREWORD

This Manual has been prepared to provide Sharp Electronics Corp. Service Personnel with Operation and Service Information for the SHARP OVER THE RANGE MICROWAVE OVEN, R-1750, R-1751, R-1752, R-1754.

It is recommended that service personnel carefully study the entire text of this manual so that they will be qualified to render satisfactory customer service.

Check the interlock switches and the door seal carefully. Special attention should be given to avoid electrical shock and microwave radiation hazard.

WARNING

Never operate the oven until the following points are ensured.

- (A) The door is tightly closed.
- (B) The door brackets and hinges are not defective.
- (C) The door packing is not damaged.
- (D) The door is not deformed or warped.
- (E) There is no other visible damage with the oven.

Servicing and repair work must be carried out only by trained service personnel.

DANGER

Certain initial parts are intentionally not grounded and present a risk of electrical shock only during servicing. Service personnel - Do not contact the following parts while the appliance is energized;

Inverter unit that includes High Voltage Capacitor, High Voltage Power Transformer, High Voltage Rectifier, Heat sink, etc., and Magnetron, High Voltage Harness etc.;
If provided, Vent Hood, Fan assembly, Cooling Fan Motor.

All the parts marked "*" on parts list are used at voltages more than 250V.

Removal of the outer wrapper gives access to voltage above 250V.

All the parts marked "Δ" on parts list may cause undue microwave exposure, by themselves, or when they are damaged, loosened or removed.

PRODUCT DESCRIPTION

GENERAL INFORMATION

OPERATION

TROUBLESHOOTING GUIDE AND
TEST PROCEDURE

TOUCH CONTROL PANEL

COMPONENT REPLACEMENT
AND ADJUSTMENT PROCEDURE

WIRING DIAGRAM

PARTS LIST

SHARP ELECTRONICS CORPORATION

SHARP PLAZA, MAHWAH,
NEW JERSEY 07430-2135

PRODUCT SPECIFICATION

ITEM	DESCRIPTION
Power Requirements	120 Volts / 14 Amperes / 1600 W 60 Hertz Single phase, 3 wire grounded
Power Output	1100 watts (IEC TEST PROCEDURE) Operating frequency of 2450MHz
Case Dimensions	Width 29-15/16" Height 16-3/8" Depth 16- 1/8" (Not including the door handle)
Cooking Cavity Dimensions 1.6 Cubic Feet	Width 21" Height 8-7/8" Depth 14-7/16"
Hood lamp	2 bulbs, 20W x 2, Incandescent light bulbs
Hood fan	Approx. 300 C.F.M.
Control Complement	Touch Control System Clock (1:00 - 12:59) Timer (0 - 99 min. 99 seconds) Microwave Power for Variable Cooking Repetition Rate; P-HI Full power throughout the cooking time P-90 approx. 90% of Full Power P-80 approx. 80% of Full Power P-70 approx. 70% of Full Power P-60 approx. 60% of Full Power P-50 approx. 50% of Full Power P-40 approx. 40% of Full Power P-30 approx. 30% of Full Power P-20 approx. 20% of Full Power P-10 approx. 10% of Full Power P-0 No power throughout the cooking time TOUCH SCREEN, ONE TOUCH SENSOR pads, Beverage Center pad Keep Warm pad, Defrost pad, MINUTE PLUS pad, STOP/CLEAR pad START pad, 6 x 6 NO GUESS COOKING pads MORE FROM YOUR MICROWAVE 6 x 6 pad, Fan Options pad Light Options pad, Turntable On/Off pad, Set Up pad
Oven Cavity Light	20W x 1 Incandescent light bulb
Safety Standard	UL Listed FCC Authorized DHHS Rules, CFR, Title 21, Chapter 1, Subchapter J
Weight	Approx. 46 lbs.

GENERAL INFORMATION

GROUNDING INSTRUCTIONS

This oven is equipped with a three prong grounding plug. It must be plugged into a wall receptacle that is properly installed and grounded in accordance with the National Electrical Code and local codes and ordinances.

In the event of an electrical short circuit, grounding reduces the risk of electric shock by providing an escape wire for the electric current.

WARNING: Improper use of the grounding plug can result in a risk of electric shock.

Electrical Requirements

The oven is equipped with a 3-prong grounding plug. **DO NOT UNDER ANY CIRCUMSTANCES CUT OR REMOVE THE GROUNDING PIN FROM THE PLUG.**

The power supply cord and plug must be connected to a separate 120 Volt AC, 60 Hz, 15 Amp. or more dedicated line, using a grounded receptacle. The receptacle should be located inside the cabinet directly above the Microwave Oven/Hood system mounting location.

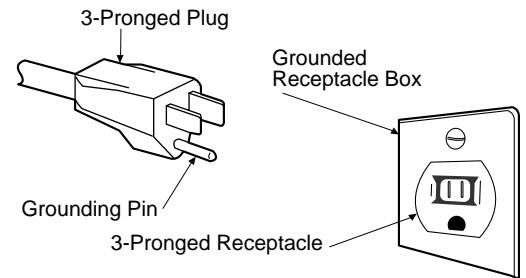
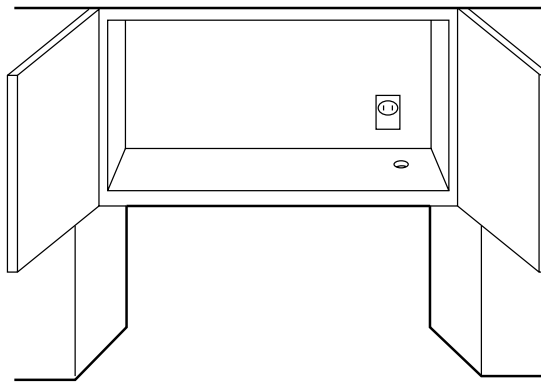

OVEN DIAGRAM

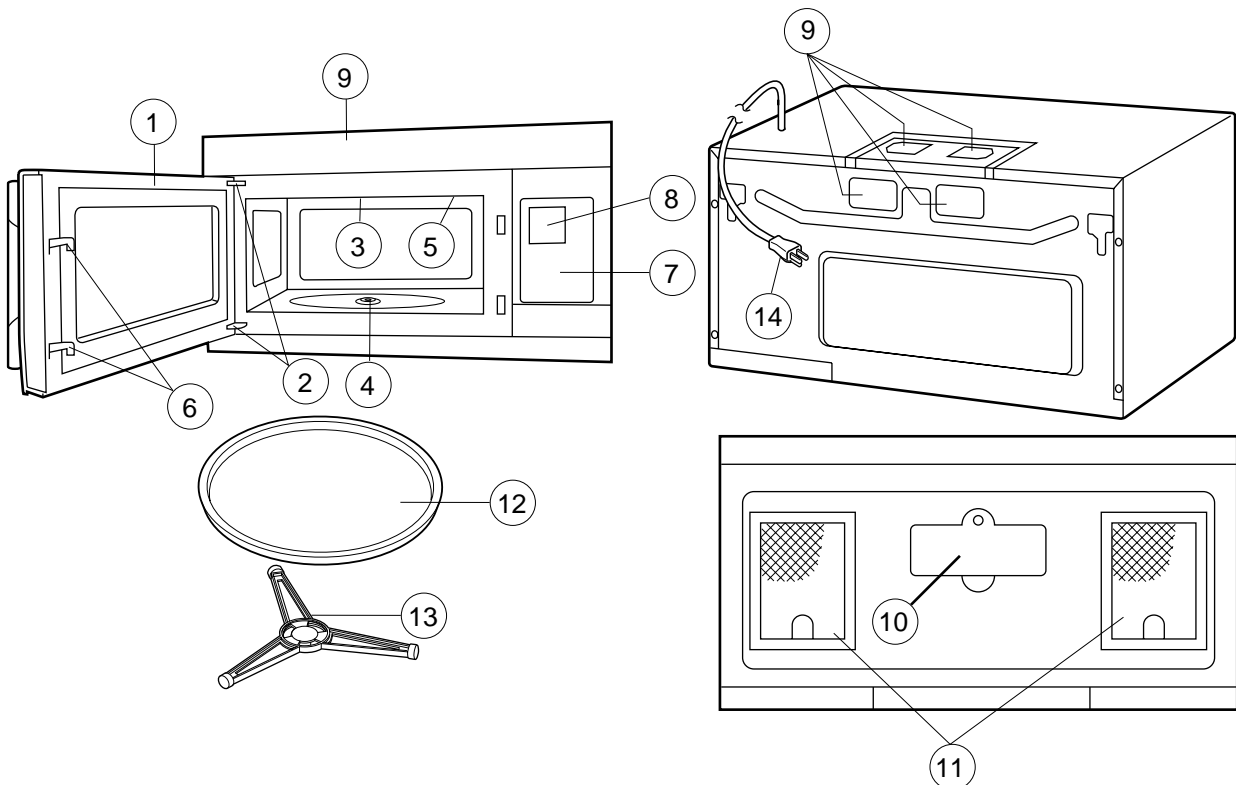

1. Oven door with see-through window.
2. Door hinges.
3. Stirrer cover.
4. Turntable motor shaft.
5. Oven lamp.
It will light when oven is operating or door is open.
6. Door latches.
The oven will not operate unless the door is securely closed.
7. Auto-Touch control panel.

8. Touch Screen.
9. Ventilation openings.
10. Light Cover.
11. Grease filters.
12. Removable turntable.
The turntable will rotate clockwise or counterclockwise.
Only remove for cleaning.
13. Removable turntable support.
14. Power supply cord

CONTROL PANEL

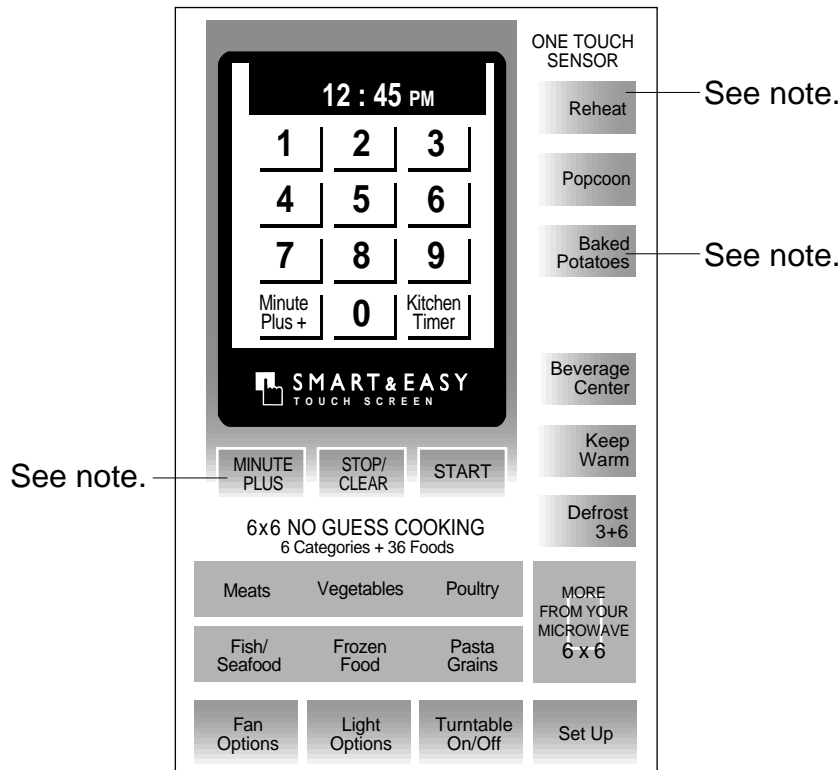

NOTE:

The directed features are disabled after three minutes when the oven is not in use. These features are automatically enabled when the door is opened and closed or the STOP/ CLEAR pad is pressed.

OPERATION

DESCRIPTION OF OPERATING SEQUENCE

The following is a description of component functions during oven operation.

OFF CONDITION

Closing the door activates the stop switch, primary interlock switch and secondary interlock switch. (In this condition, the monitor switch contacts are opened.)

When oven is plugged in, 120 volts A.C. is supplied to the control unit (Figure O-1).

1. "Set clock" key and "Video demo" key will be appeared on the touch screen.
2. Touch "Set clock" key and set the clock referring to the operation manual.

NOTE: If no keys are touched within 30 seconds, the touch screen will go on to the Video Demo mode. To cancel the Video Demo mode, touch the STOP/ CLEAR pad. And then set the clock.

3. The touch screen will show the home page after setting the clock.

4. The following is an example of the Home page when the time of the day is set to 12:30 p.m..

	12 : 30 PM	
1	2	3
4	5	6
7	8	9
Minute Plus +	0	Kitchen Timer

NOTE: Even if the clock is not set, the display will show the Home page by touching the STOP/CLEAR pad within 30 seconds after being plugged in.

COOKING CONDITION

Program desired cooking time touching the NUMBER pads. When the START pad is touched, the following operations occur:

- The contacts of relays are closed and components connected to the relays are turned on as follows.
(For details, refer to Figure O-2)

RELAY	CONNECTED COMPONENTS
RY1	Oven lamp / Fan motor / Stirrer motor
RY2	Turntable motor
RY3, RY4	Hood fan motor

- 120 volts A.C. is supplied to the inverter unit and is converted in order to power of the magnetron by the high frequency switching power circuit. The frequency is approx. 27 – 40 KHz.
- The filament winding voltage of H.V. transformer heats the magnetron filament and the H.V. winding gives a high voltage approx. 2 KV to activate a voltage doubler circuit. Then approx. 4KV peak voltage power is supplied to the magnetron cathode terminal.
- The microwave energy produced by the magnetron is channelled through the waveguide into the cavity feed-box, and then into the cavity where the food is placed to be cooked.
- Upon completion of the cooking time, the inverter unit, oven lamp, etc. are turned off, and the generation of microwave energy is stopped. The oven will revert to the OFF condition.
- When the door is opened during a cook cycle, the monitor switch, stop switch, secondary interlock switch and primary interlock switch are activated with the following results. The circuits to the stirrer motor, the cooling fan motor, the turntable motor, and the inverter unit are de-energized, and the touch screen displays the time still remaining in the cook cycle when the door was opened.
- The monitor switch is electrically monitoring the operation of the secondary interlock switch and primary interlock switch and is mechanically associated with the door so that it will function in the following sequence.

- When the door opens from a closed position, the primary interlock switch and secondary interlock switch open their contacts, and then the monitor switch contacts close. And contacts of the relay (RY1) remain closed.
- When the door is closed from the open position, the monitor switch contacts first open and the stop switch contacts open, and then the contacts of the secondary interlock switch and primary interlock switch close. And contacts of the relay (RY1) open.

If the secondary interlock switch and primary interlock switch fail with their contacts closed when the door is opened, the closing of the monitor switch contacts will form a short circuit through the monitor fuse, secondary interlock switch, primary interlock switch and relay (RY1) causing the monitor fuse to blow.

VARIABLE COOKING

When Variable Cooking Power is programmed, the 120 volts A.C. is supplied to the inverter unit which is operated by the control unit. Microwave power operation is as follows: The oven can be set for any of 11 power levels: 0% to 100%(HIGH). The variable cooking power less than 40% is

programmed at the ratio of ON time and OFF time within 32 sec./ cycle time base.

CONNECTION BETWEEN POWER SETTING AND ON/OFF TIME OF INVERTER UNIT.

OUTPUT POWER SETTING	ON TIME	OFF TIME
Power 100%		
Power 90%		
Power 80%		
Power 70%		Continue operation
Power 60%		
Power 50%		
Power 40%	26 sec.	6 sec.
Power 30%	22 sec.	10 sec.
Power 20%	16 sec.	16 sec.
Power 10%	8 sec.	24 sec.
Power 0%	0 sec.	32 sec.

Note: The ON/OFF time ratio does not correspond with the percentage of microwave power, because approx. 3 seconds are needed for heating of the magnetron filament.

SENSOR COOKING CONDITION

Using the Sensor cooking function (See sensor cooking menus), the food is cooked without figuring time, power level or quantity. When the oven senses enough steam from the food, it relays the information to its microprocessor which will calculate the remaining cooking time and power level needed for best results. When the food is cooked, water vapor is developed. The sensor "senses" the vapor and its resistance increases gradually. When the resistance reaches the value set according to the menu, supplementary cooking is started. The time of supplementary cooking is determined by experiment with each food category and input into the LSI. An example of how sensor works: (BAKED POTATOES)



- Potatoes at room temperature. Vapor is emitted very slowly.

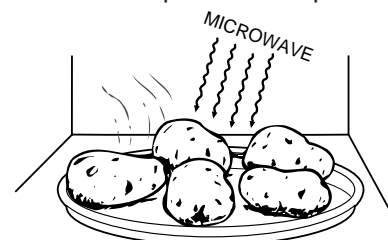

- Heat Potatoes. Moisture and humidity is emitted rapidly. You can smell the aroma as it cooks.

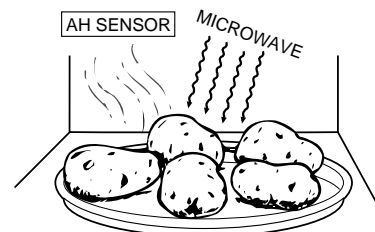

- Sensor detects moisture and humidity and calculates cooking time and variable power.

Cooking Sequence.

- Operate the oven in sensor cooking mode by referring to the operation manual.

NOTE: The oven should not be operated on SENSOR immediately after plugging in the unit. Wait two minutes before cooking on SENSOR.

- The coil of shut-off relay (RY-1) is energized, the turntable motor, oven lamp and cooling fan motor are turned on, but the inverter unit is not turned on.
- After about 32 seconds, the cook relay (RY-2) is energized. The power transformer is turned on, microwave energy is produced and first stage is started. The 32 seconds is the cooling time required to remove any vapor from the oven cavity and sensor.

NOTE: During this first stage, do not open the door or touch STOP/CLEAR pad.

- When the sensor detects the vapor emitted from the food, the display switches over to the remaining cooking time and the timer counts down to zero. At this time, the door may be opened to stir, turn, or season food.
- When the timer reaches zero, an audible signal sounds. The shut-off relay is de-energized and the inverter unit, oven lamp, etc. are turned off.
- Opening the door or touching the STOP/CLEAR pad, the time of day will reappear on the display and the oven will revert to an OFF condition.

The following are the sensor cooking menus.

- Reheat
- Popcorn
- Baked potatoes
- Vegetables
- Ground beef or Meat
- Boneless Chicken Breast, Bone-in Chicken Pieces and Ground Poultry of Poultry
- Fish / Seafood
- Vegetables, Entrees, Main Dishes and Snacks of Frozen food
- White Rice and Brown Rice of Pasta Grains
- Frozen breakfast food, Meal in cup, Hot dogs in buns, Soup, Frozen sandwich, Stuffed Acorn Squash, Ratatouille, Bacon, Microwave pizza of More From Your Microwave.

VENTILATION METHODS HOT AIR EXHAUST

1. VERTICAL VENTING

For this venting method, hot air rising from the conventional range below is drawn in by the hood fan motor through the grease filters at the right and left sides of the base cover, up through the right and left sides of the oven cavity, then discharged vertically at rear center top of the oven, into the customer's vent system.

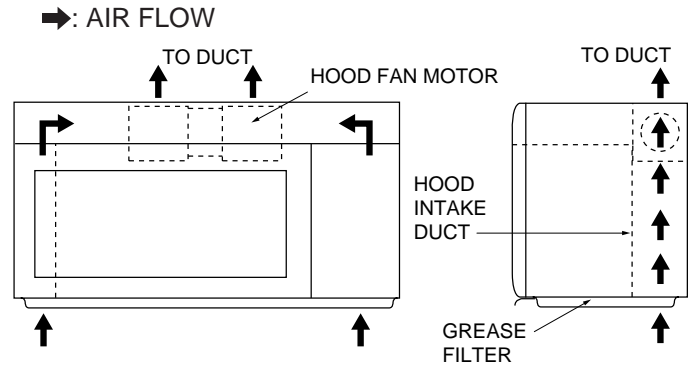

2. HORIZONTAL VENTING

The air handling is the same as VERTICAL VENTING except that the final air discharge is directed horizontally out from the top rear of the oven into the customer's vent system.

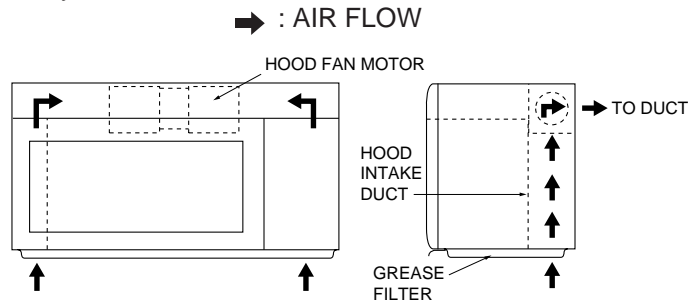

3. RE-CIRCULATION (INSIDE VENTING)

The air handling is the same as VERTICAL VENTING except that the final air discharge is directed horizontally through the upper front of the oven into the kitchen. In this case, the accessory charcoal filter RK-230 must be provided to filter the air before it leaves the oven.

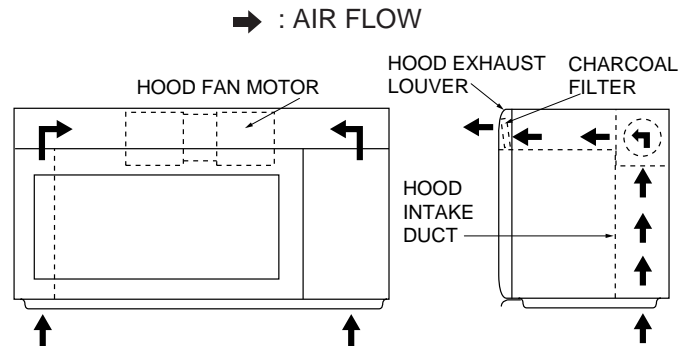

BASIC OPERATION OF INVERTER CIRCUIT

Basic circuit diagram is shown Figure A-1.

AC line voltage is rectified and converted to direct-current voltage (DC Voltage). By switching the power transistor Q1 ON and OFF, High frequency current (about 27 - 40 KHz) is generated controlled by the IC of the inverter unit. OFF-time of the transistor Q1 is nearly constant. That is, on-time is varied. It is a kind of Pulse Width Modulation (PWM). Because off-time is constant, switching frequency is varied in response to the length of on-time and output power of magnetron is proportional to the length of on-time. Therefore, the frequency of inverter becomes low for high output and high for low output.

Wave-form of main parts are shown in Figure A-2. During off-time, flyback voltage appears on the primary winding of the high voltage transformer. The off-time depends on the inductance of the transformer and capacitance of the resonant capacitor C3. Synchronous circuit generates the timing signal by detecting the flyback voltage. The power transistor Q1 is periodically switched on when the collector voltage returns to zero (0) volt. High voltage (about 2 KV) appears on secondary winding of the transformer. The full-wave voltage doubler circuit increase to about 4 KV and is applied to the magnetron. The efficiency of the inverter unit itself is approx. 93%, and equal to that of current efficiency. Ferrite core is used for the high voltage transformer. It is superior to silicon steel core at high frequency, low magnetic loss. The power level is determined by the touch control board, and the PWM data corresponding to the level is set to the IC of the inverter unit through the control lines. The IC controls on-time of transistor Q1 by comparing the average value of the primary current with the magnitude of the power level data. The IC has the protection circuit which detects over-current of the main circuit and the high voltage circuit, over-voltage of the power transistor Q1 and AC power interruption. When abnormal phenomenon is detected, the IC pauses on the moment in order to protect the power transistor Q1 from

being destroyed. After approx. 60 millisecond, it starts generating the driving signal from the minimum pulse width and expands the length of on-time slowly until the current of the main circuit reaches the target level.

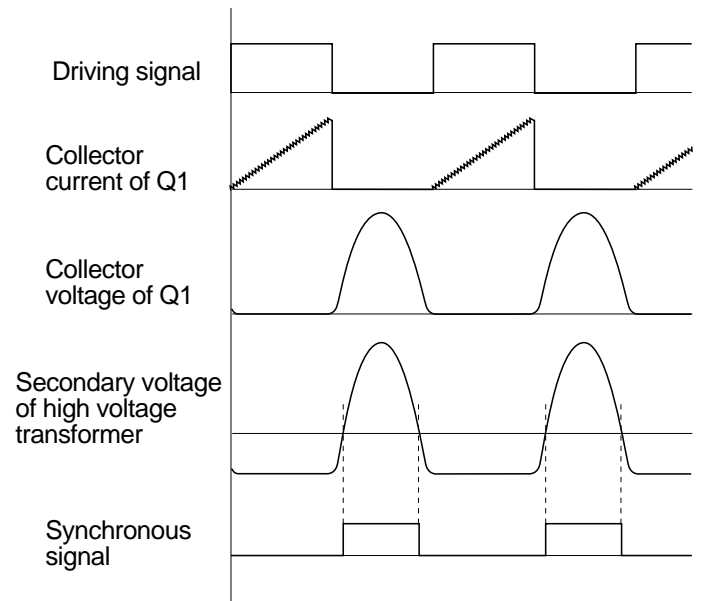

Figure A-2. Switching Wave-form

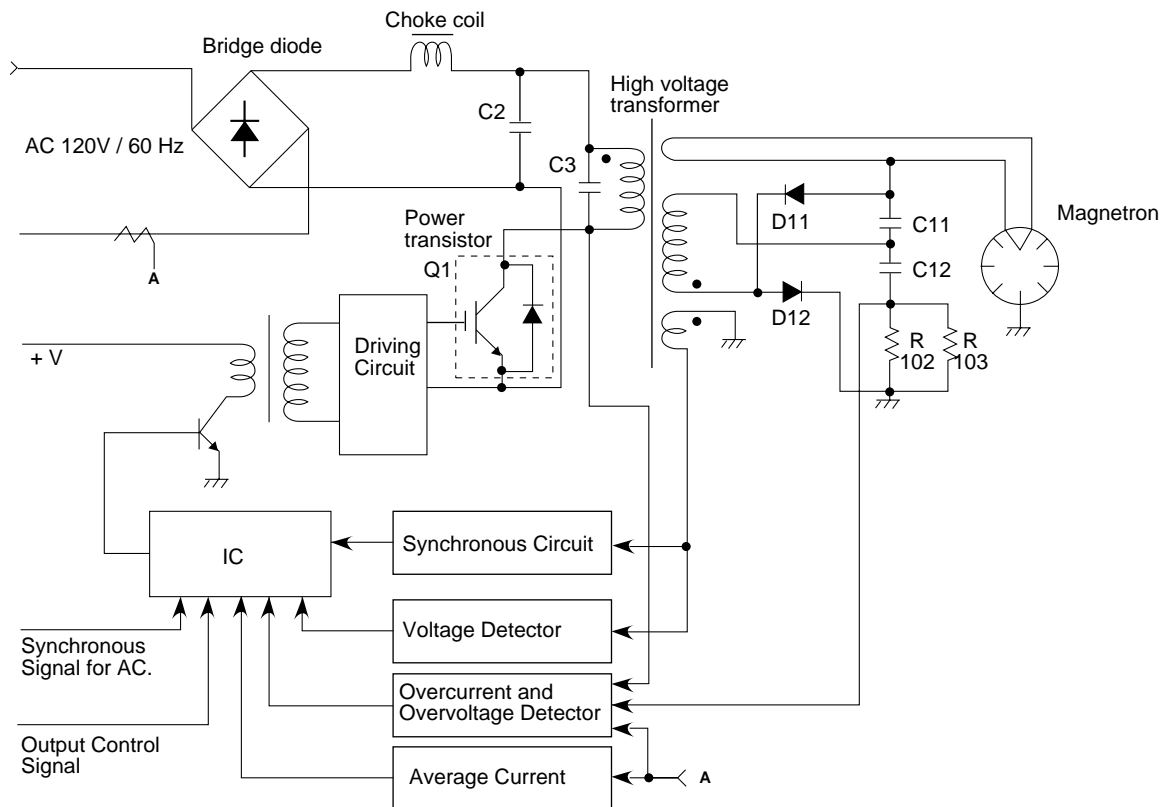

Figure A-1. Basic Circuit

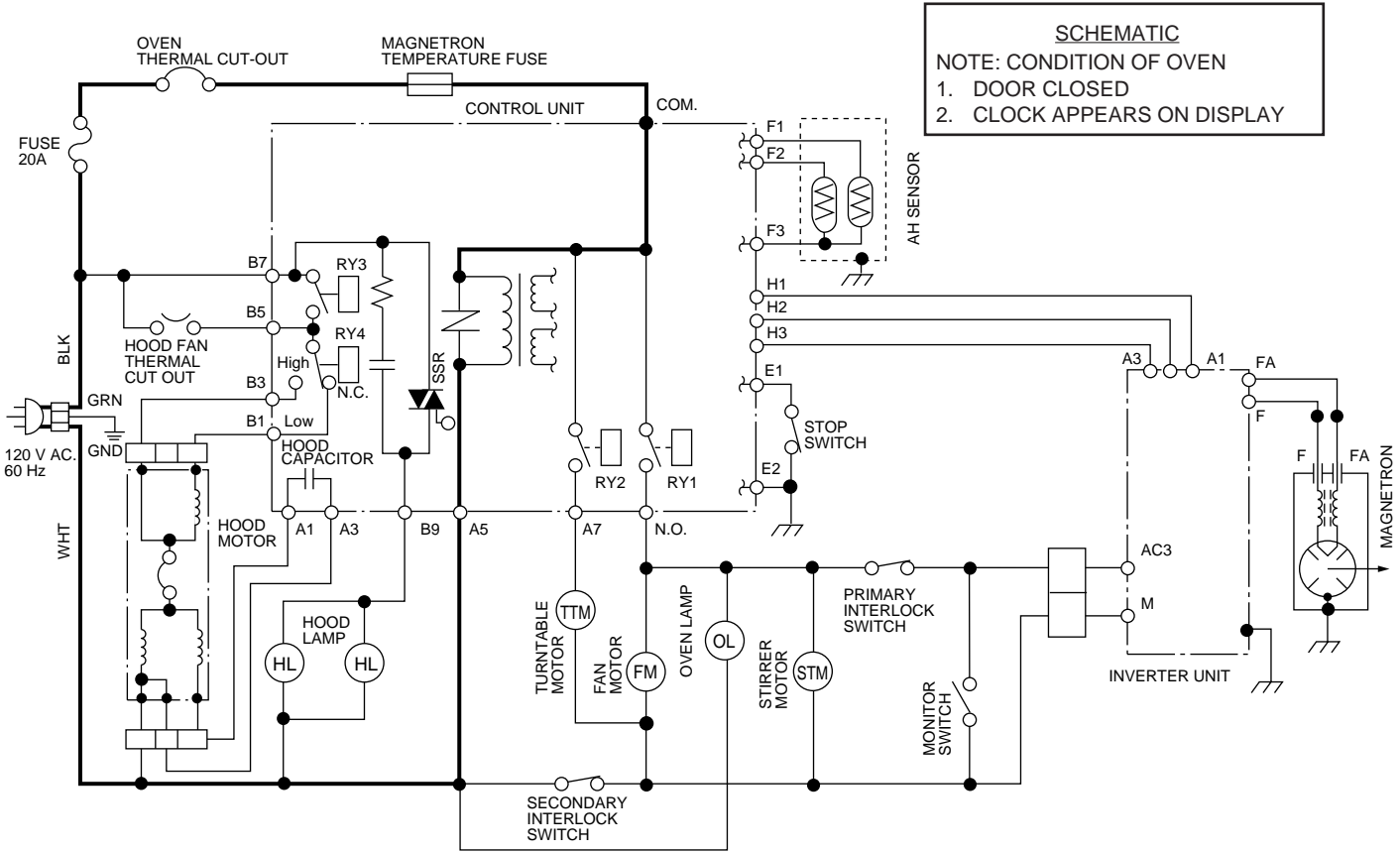

Figure O-1. Oven Schematic-Off Condition

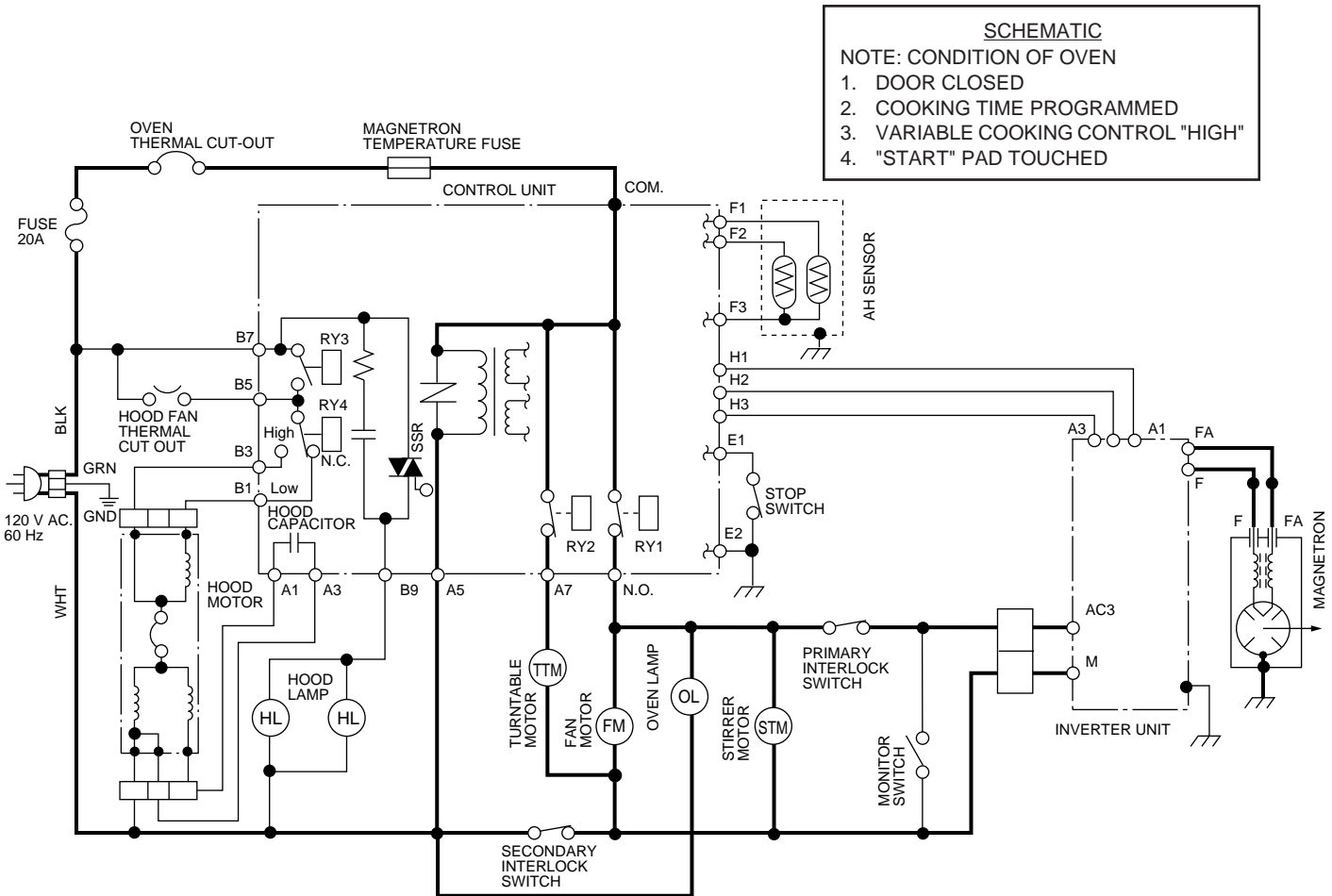

Figure O-2. Oven Schematic-Cooking Condition

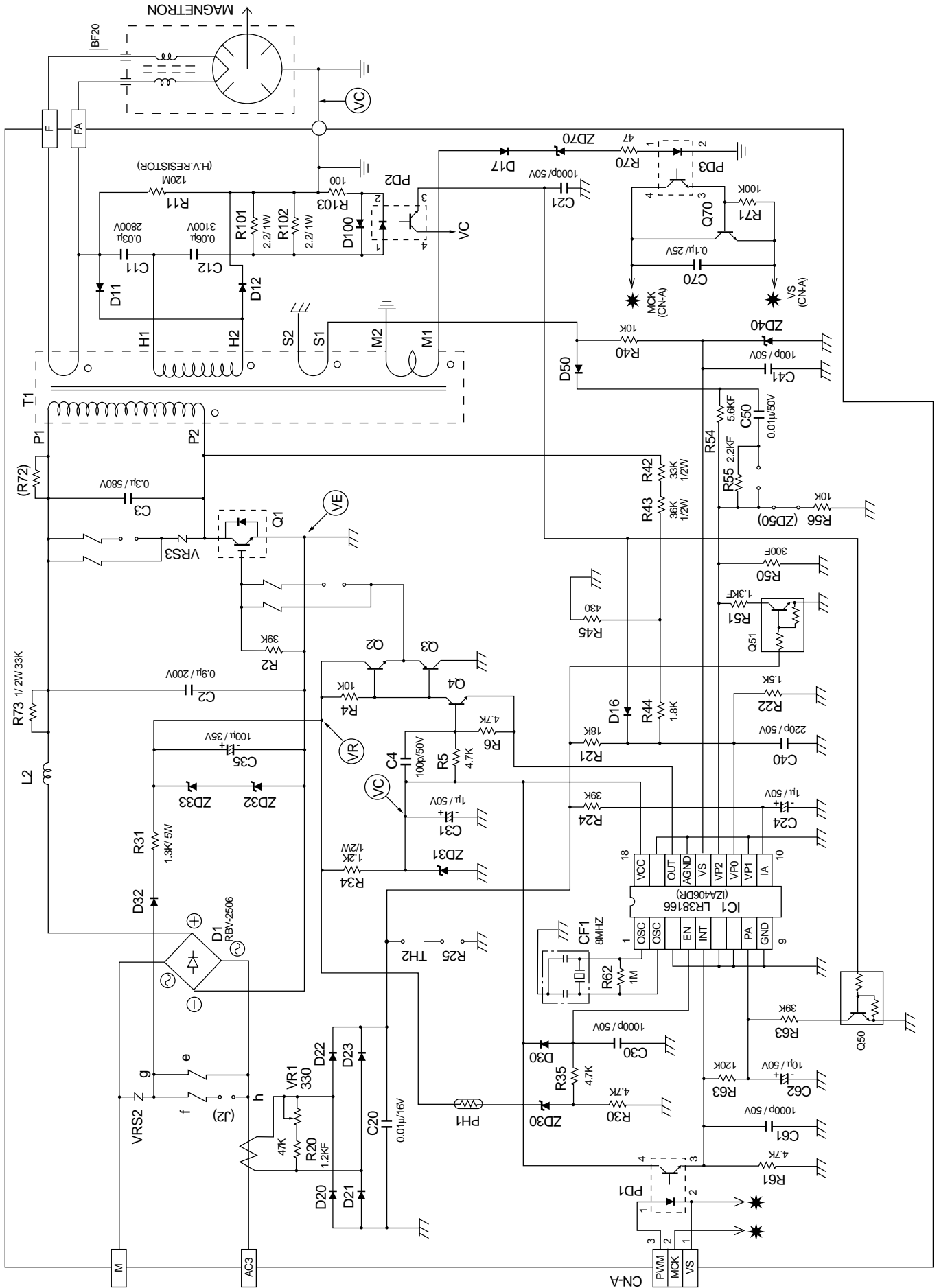

Figure O-3. Inverter Unit Circuit

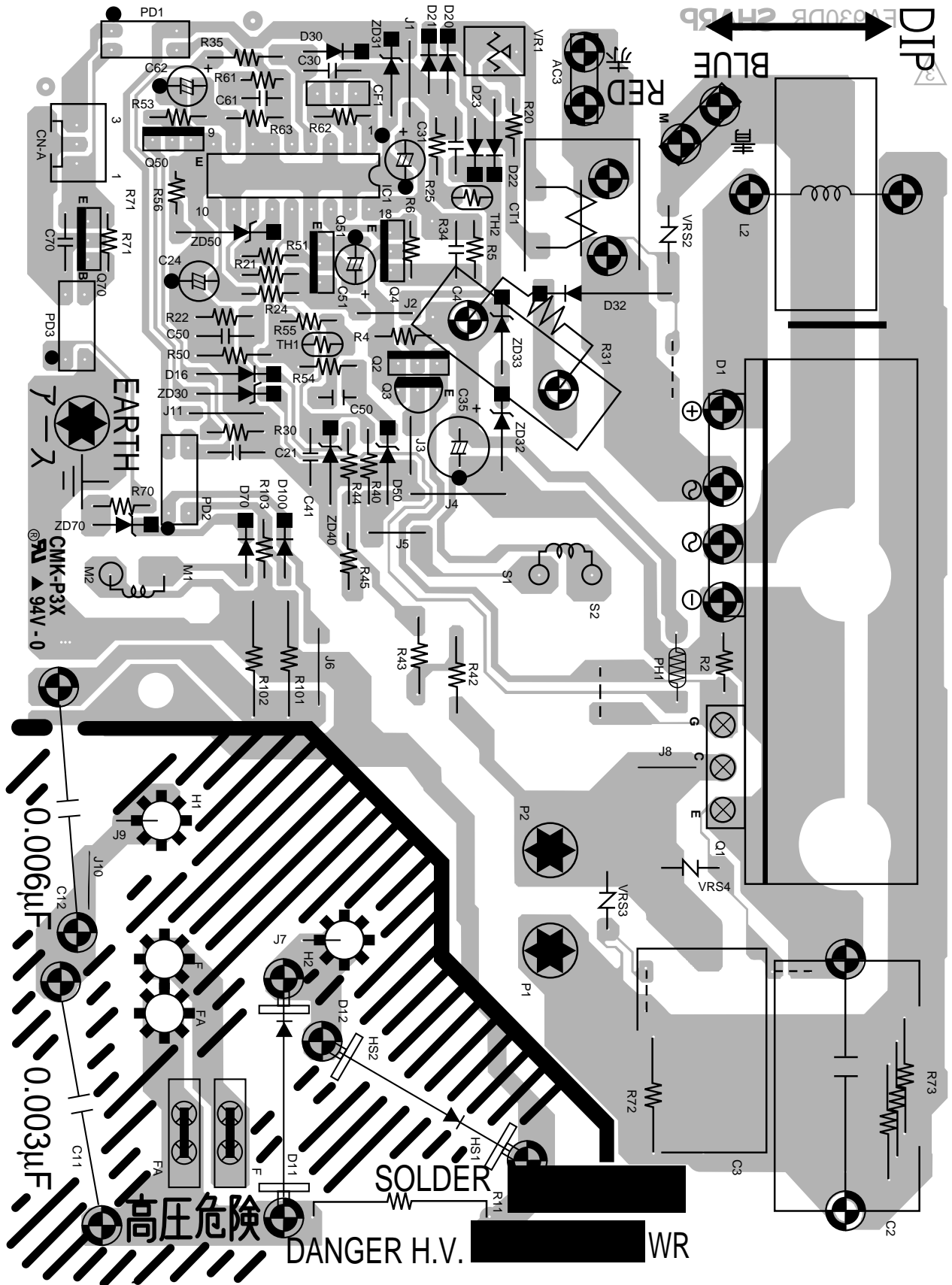

Figure O-4. Printed Wiring Board for Inverter Unit Circuit

DESCRIPTION AND FUNCTION OF COMPONENTS

DOOR OPEN MECHANISM

The door is opened by pulling the door handle, refer to the Figure D-1.

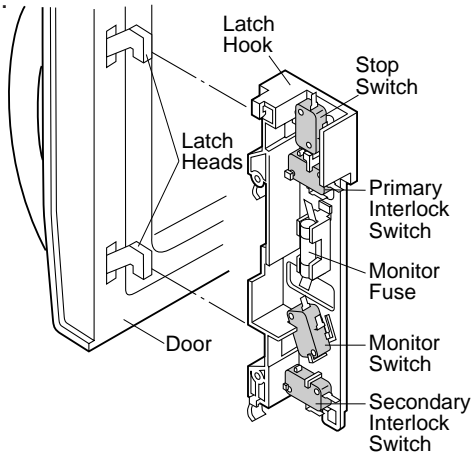

Figure D-1. Door Open Mechanism

STOP, PRIMARY INTERLOCK AND SECONDARY INTERLOCK SWITCHES

The secondary interlock switch is mounted in the lower position of the latch hook and the stop switch is mounted in the upper position of the latch hook. The primary interlock switch is also in the upper position of the latch hook. They are activated by the latch heads on the door. When the door is opened, the switches interrupt the circuit to all components. A cook cycle cannot take place until the door is firmly closed thereby activating both interlock switches.

MONITOR SWITCH

The monitor switch is activated (the contacts opened) by the latch head on the door while the door is closed. The switch is intended to render the oven inoperative by means of blowing the monitor fuse when the contacts of the primary interlock switch and secondary interlock switch fail to open when the door is opened.

Functions:

1. When the door is opened, the monitor switch contact close (to the ON condition) due to their being normally closed. At this time the primary interlock switch and secondary interlock switch are in the OFF condition (contacts open) due to their being normally open contact switches. And the contacts of relay (RY1) are in the ON condition (contacts close).
2. As the door goes to a closed position, the monitor switch contacts are first opened and the stop switch contacts close, and then the primary interlock switch and the secondary interlock switch contacts close. (On opening the door, each of these switches operate inversely.)
3. If the door is opened, and the primary interlock switch and secondary interlock switch contacts fail to open, the monitor fuse blows simultaneously with closing of the monitor switch contacts.

CAUTION: BEFORE REPLACING A BLOWN MONITOR FUSE TEST THE STOP SWITCH, PRIMARY INTERLOCK SWITCH, SECONDARY INTER-

LOCK SWITCH AND MONITOR SWITCH FOR PROPER OPERATION. (REFER TO CHAPTER "TEST PROCEDURE").

NOTE: MONITOR FUSE AND SWITCH ARE REPLACED AS AN ASSEMBLY

TEMPERATURE FUSE (MG)

The temperature fuse located near the waveguide is designed to prevent damage to the magnetron if an over heated condition develops in the tube due to cooling fan failure, obstructed air guide, dirty or blocked air intake, etc. Under normal operation, the temperature fuse remains closed. However, the temperature fuse will open at 302°F (150°C) causing the oven to shut down.

THERMAL CUT-OUT (HOOD)

This thermal cut-out located on the right base plate. It is designed to automatically turn on the hood fan motor whenever the hot air rising from the conventional range below causes the temperature at the thermal cut-out to rise to 140°F (60°C) or higher, thus removing this hot air from around microwave oven. When the temperature around the thermal cut-out drops to 113°F (45°C) or lower, the thermal cut-out shuts off the hood fan motor.

THERMAL CUT-OUT (OVEN)

This thermal cut-out is located on the top of the oven cavity. It is designed to prevent damage to the oven unit if the food in the oven catches fire due to overheating produced by improper setting of cooking time or failure of control unit. Under normal operation, the thermal cut-out remains closed. However, the thermal cut-out will open at 293°F (145°C) causing the oven to shut down.

TURNTABLE MOTOR

The turntable motor rotates the turntable located on the bottom of the oven cavity, so that the foods on the turntable cook evenly during cooking. Turntable will turn in either direction. The turntable motor can be turned off by touching TURNTABLE ON/OFF pad.

COOLING FAN MOTOR

The cooling fan motor drives a blade which draws external cool air. This cool air is directed through the air vanes surrounding the magnetron and cools the magnetron. This air is channelled through the oven cavity to remove steam and vapors given off from the heating foods. It is then exhausted through the exhausting air vents at the oven cavity.

HOOD FAN MOTOR

The hood fan motor is a two-speed, single-phase, double pole induction type, requiring a hood fan capacitor. It is located outside the upper rear part of the oven cavity, is to remove, from around the oven, hot air rising from the conventional electric or gas range over which it is installed. This air is then expelled either vertically or horizontally through the customer supplied duct system, or discharged back into the kitchen.

STIRRER MOTOR

The stirrer motor drives the stirrer fan to stir the microwave radiation from the waveguide.

HOOD LAMP

The hood lamps are mounted at the hood lamp angle on the base cover. The hood lamps can be turned off and on by touching the Light Options pad. And also the brightness can be varied to high or low by touching the Light Options pad.

TROUBLESHOOTING GUIDE

Never touch any part in the circuit with your hand or an uninsulated tool while the power supply is connected.

When troubleshooting the microwave oven, it is helpful to follow the Sequence of Operation in performing the checks. Many of the possible causes of trouble will require that a specific test be performed. These tests are given a procedure letter which will be found in the "Test Procedure "section.

IMPORTANT: If the oven becomes inoperative because of a blown monitor fuse, check the monitor switch, relay (RY1) primary interlock switch and secondary interlock switch before replacing the monitor fuse. If monitor fuse is replaced, the monitor switch must also be replaced. Use part FFS-BA016/KIT as an assembly.

IMPORTANT: Whenever troubleshooting is performed with the power supply cord disconnected. It may in, some cases, be necessary to connect the power supply cord after the outer case has been removed, in this event,

1. Disconnect the power supply cord, and then remove outer case.
2. Open the door and block it open.
3. Discharge high voltage capacitor.
4. Disconnect the leads to the primary of the power transformer.
5. Ensure that the leads remain isolated from other components and oven chassis by using insulation tape.
6. After that procedure, reconnect the power supply cord.

When the testing is completed

1. Disconnect the power supply cord, and then remove outer case.
2. Open the door and block it open.
3. Discharge high voltage capacitor.
4. Reconnect all leads removed from components during testing.
5. Reinstall the outer case (cabinet).
6. Reconnect the power supply cord after the outer case is installed.
7. Run the oven and check all functions.

TEST PROCEDURE																					
CONDITION	PROBLEM	A	B	C	D	D	E	F	G	H	I	J	K	L	L	L	M	N	O	RE	CK
	POSSIBLE CASE AND DEFECTIVE PARTS																				
	Home fuse blows when power cord is plugged into wall receptacle.		●																	●	
	Monitor fuse blows when power cord is plugged into wall receptacle.		●																		●
	Display does not illuminate when power cord is first plugged into wall receptacle.																				●
OFF CONDITION	Display does not operate properly when STOP/CLEAR key is touched. (The time of day should appear on the display with beep sound during normal condition.)						●					●									●
	Oven lamp does not light with door is opened.																				●
	Hood fan motor operates when power cord is first plugged into wall receptacle.																				●
	Temperature of oven base seems more than 140°F (60°C) because of operation of the range below. But hood fan motor does not turn on automatically. (Normally, food fan motor should be operating at low speed.)																				●
IDLE CONDITION	Hood lights do not turn on when Light Options pad is pressed.																				●
	Hood fan motor does not rotate at all with touched Fan Options pad.																				●
	Speed of the hood fan motor does not change when the Fan Options pad is touched for this function.																				●
	Oven lamp does not light in cook cycle. (But it does light when door is opened.)																				●
	Fan motor does not operate. (Oven lamp and turntable motor operate.)																				●
	Turntable motor does not operate (Oven lamp lights and fan motor operates.)																				●
	Oven does not go into cook cycle when START pad is touched																				●
MICROWAVE COOKING CONDITION	Oven seems to be operating but little or no heat is produced in oven load. (Food incompletely cooked or not cooked at all at end of cook cycle.)																				●
	Oven goes into a cook cycle but extremely uneven heating is produced in oven load (food).																				●
	Variable cooking does not operate properly except Cooking Power 100% mode.																				●
	Function of COMPU DEFROST does not operate properly.																				●
	Stirrer motor does not operate. (Other parts operate.)																				●
	Oven goes into COMPU DEFROST but food is not defrosted well.																				●
SENSOR COOKING CONDITION	The oven Stops and "ERROR" is displayed or does not end during Sensor Cooking condition. (Oven does not shut off after a cup of water is boiling by Sensor Cooking.)																				●
	Oven stops at 32 seconds after starting.																				●

TEST PROCEDURES

PROCEDURE LETTER	COMPONENT TEST
A	<u>MAGNETRON ASSEMBLY TEST</u> <ol style="list-style-type: none">1. Disconnect the power supply cord, and then remove outer case.2. Open the door and block it open.3. To discharge high voltage capacitor, wait for 60 seconds.4. To test for an open filament, isolate the magnetron from the high voltage circuit. A continuity check across the magnetron filament leads should indicate less than 1 ohm.5. To test for a shorted magnetron, connect the ohmmeter leads between the magnetron filament leads and chassis ground. This test should indicate an infinite resistance. If there is little or no resistance the magnetron is grounded and must be replaced.6. Reconnect all leads removed from components during testing.7. Reinstall the outer case (cabinet).8. Reconnect the power supply cord after the outer case is installed.9. Run the oven and check all functions. MICROWAVE OUTPUT POWER <p>The following test procedure should be carried out with the microwave oven in a fully assembled condition (outer case fitted).</p> <p>HIGH VOLTAGES ARE PRESENT DURING THE COOK CYCLE, SO EXTREME CAUTION SHOULD BE OBSERVED.</p> <p>Power output of the magnetron can be measured by performing a water temperature rise test. This test should only be used if above tests do not indicate a faulty magnetron and there is no defect in the following components or wiring: silicon rectifier, high voltage capacitor and power transformer. This test will require a 16 ounce (453cc) measuring cup and an accurate mercury thermometer or thermocouple type temperature tester. For accurate results, the following procedure must be followed carefully:</p> <ol style="list-style-type: none">1. Fill the measuring cup with 16 oz. (453cc) of tap water and measure the temperature of the water with a thermometer or thermocouple temperature tester. Stir the thermometer or thermocouple through the water until the temperature stabilizes. Record the temperature of the water.2. Place the cup of water in the oven. Operate oven at POWER 10(HIGH) selecting more than 60 seconds cook time. Allow the water to heat for 60 seconds, measuring with a stop watch, second hand of a watch or the digital read-out countdown.3. Remove the cup from the oven and again measure the temperature, making sure to stir the thermometer or thermocouple through the water until the maximum temperature is recorded.4. Subtract the cold water temperature from the hot water temperature. The normal result should be 29.9 to 55.4°F (16.6 to 30.8°C) rise in temperature. If the water temperatures are accurately measured and tested for the required time period the test results will indicate if the magnetron tube has low power output (low rise in water temperature) which would extend cooking time or high power output (high rise in water temperature) which would reduce cooking time. Because cooking time can be adjusted to compensate for power output, the magnetron tube assembly should be replaced only if the water temperature rise test indicates a power output well beyond the normal limits. The test is only accurate if the power supply line voltage is 120 volts and the oven cavity is clean.
B	<u>INVERTER UNIT TEST</u> <p>WARNING: DO NOT TOUCH THE COMPONENTS OF THE INVERTER UNIT WHILE INVERTER UNIT IS ENERGIZED. IT IS DANGEROUS BECAUSE THIS HAS HIGH VOLTAGE COMPONENTS.</p> <ol style="list-style-type: none">1. Disconnect the power supply cord, and then remove outer case.2. Open the door and block it open.3. To discharge high voltage capacitor, wait for 60 seconds.4. Isolate the inverter unit electrically.5. Check the inverter unit by referring the following chart and test procedure.

TEST PROCEDURES

PROCEDURE LETTER	COMPONENT TEST
------------------	----------------

Chart for checking the defective inverter unit

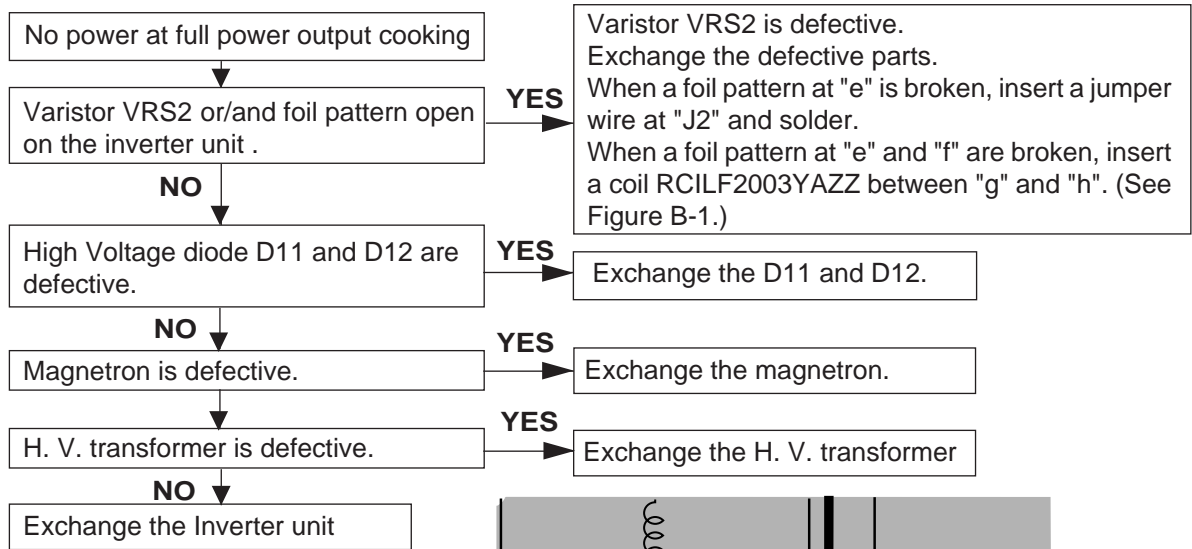

NOTE: "e", "f", "g", "h" and "(J2)" are not indicated on P.W.B.

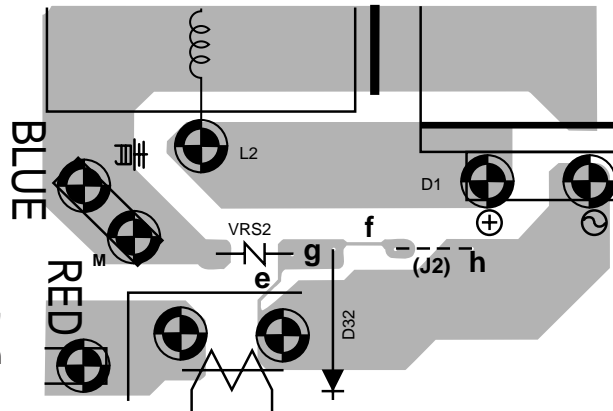
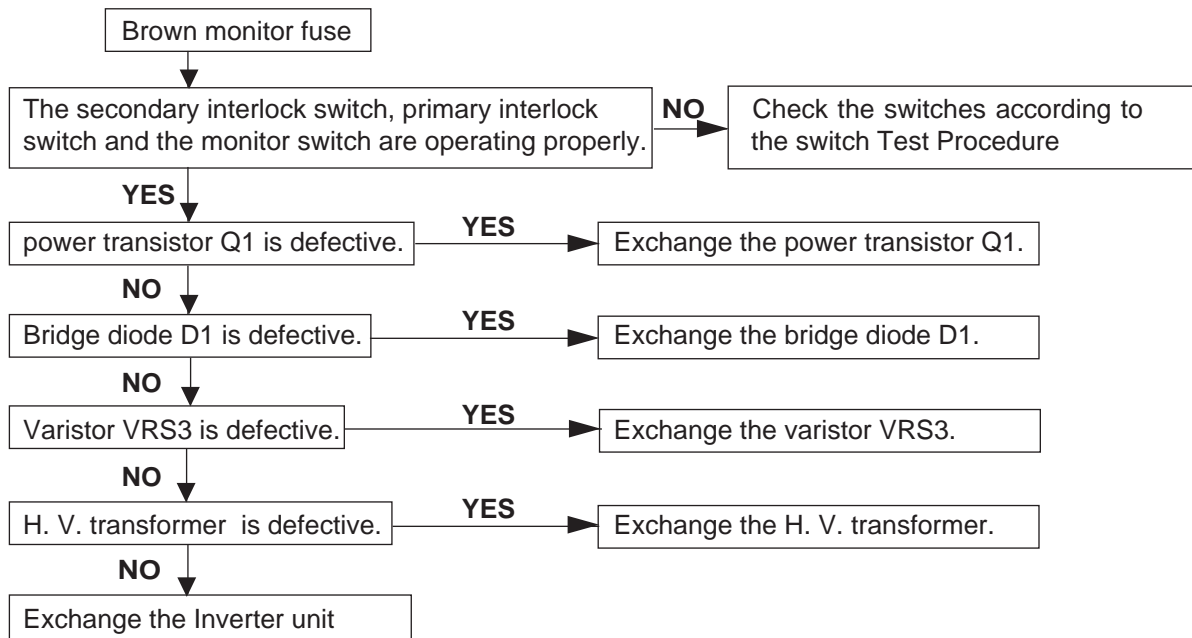

Figure B-1 Foil pattern circuit on Inverter Unit



TEST PROCEDURES

**PROCEDURE
LETTER**

COMPONENT TEST

Description of main parts

SYMBOL	PART NAME	FUNCTION
C11, C12	High voltage capacitor	High voltage capacitor for doubler circuit.
C2	Film capacitor	To smooth line ripple
C3	Film capacitor	Capacitor for resonant
CT1	Current transformer	To detect power current
D1	Bridge Diode	To rectify full-wave of power supply
D11, D12	High voltage diode	Full wave voltage doubler
IC1	Integrated Circuit (IC)	Inverter circuit controller
L2	Choke Coil	To smooth line ripple
Q1	Transistor	Power transistor for switching
Q2, Q3	Transistor	To drive transistor Q1 ON-OFF
T1	High voltage transformer assembly	High voltage transform for high frequency

Test procedure

1. Power transistor Q1

Check the transistor Q1 by using ohmmeter as shown in Figure B-2

If transistor Q1 is defective exchange Q1.

Check the bridge diode D1, transistor Q2 and transistor Q3 by using ohmmeter and replace them if they are defective.

NOTE: When a digital ohmmeter is used, reverse the connection of ohmmeter leads against Figure B-2.

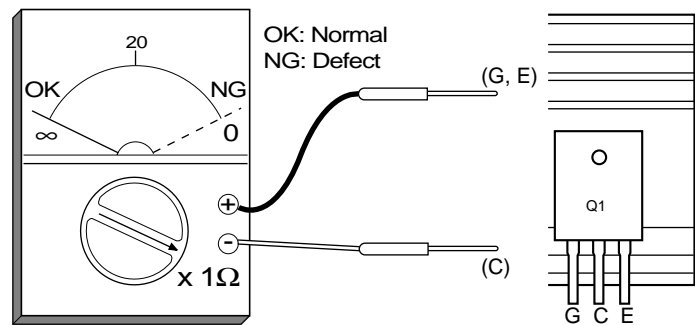

Figure B-2. Check for Power Transistor Q1

2. High voltage diode D11 and D12

Check these diodes by using ohmmeter as shown in Figure B-2.

If one of the diode is shorted, exchange both diodes D11 and D12.

NOTE: When a digital ohmmeter is used, reverse the connection of ohmmeter leads against Figure B-3.

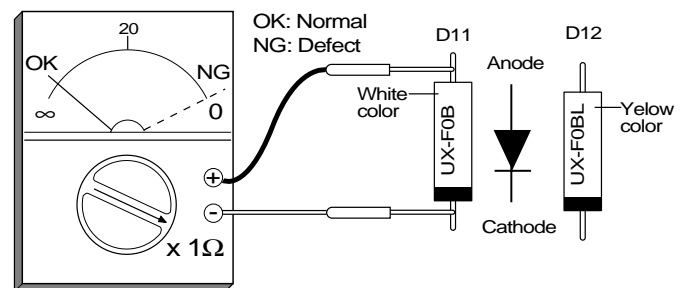

Figure B-3. Check for high voltage diode D11 & D12

3. Bridge diode D1

Check the diode D1 by using ohmmeter as shown in Figure B-4.

If the diode D1 is defective, exchange D1 and power transistor Q1 at same time (Q1 is defective)

NOTE: When a digital ohmmeter is used, reverse the connection of ohmmeter leads against Figure B-4.

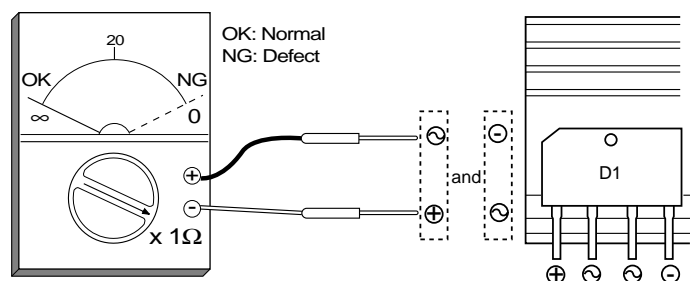

Figure B-4. Check for bridge diode D1.

TEST PROCEDURES

PROCEDURE LETTER	COMPONENT TEST
------------------	----------------

4. Transistor Q2 and Q3

Check the resistance of transistor Q2 and Q3 by using ohmmeter as shown in Figure B-5.

The resistance between B and E of transistor Q2 and Q3 is approx. 20Ω

The resistance between C and E is over range.

If incorrect resistance appear, replace it.

NOTE: When a digital ohmmeter is used, reverse the connection of ohmmeter leads against Figure B-5.

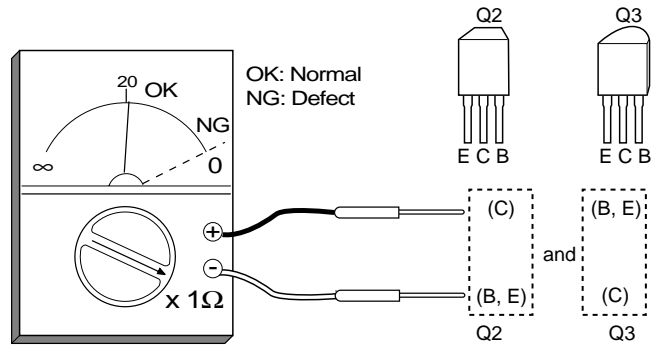

Figure B-5. Check for transistor Q2 and Q3.

After check of inverter unit;

CAUTION: DO NOT OPERATE INVERTER UNIT BY ITSELF.

1. Install the inverter unit to the microwave oven securely.
2. Reconnect all leads removed from components during testing.
3. Reinstall the outer case (cabinet).
4. Reconnect the power supply cord after the outer case is installed.

CAUTION: DO NOT CONNECT THE OVEN TO WALL OUTLET WITHOUT THE OUTER CASE INSTALLED.

5. Measure the microwave output power at full power cooking operation (refer to Test Procedure of Magnetron Test in the Service manual) or measure the input current at full power and 50% power level. Input current is approx. 8A at 50% power level operation and approx. 15A at full power operation.

C OVEN THERMAL CUT-OUT TEST

1. Disconnect the power supply cord, and then remove outer case.
2. Open the door and block it open.
3. To discharge high voltage capacitor, wait for 60 seconds.
4. A continuity check across the thermal cut-out terminals should indicate a closed circuit unless the temperature of the thermal cut-out reaches approximately 293°F(145°C).
An open thermal cut-out indicates overheating of the oven, exchange the oven thermal cut-out and check inside of oven cavity and for improper setting of cooking time or operation of control unit. Check for restricted air flow through the vent holes of the oven cavity, especially the cooling fan and air guide.
5. Reconnect all leads removed from components during testing.
6. Reinstall the outer case (cabinet).
7. Reconnect the power supply cord after the outer case is installed.
8. Run the oven and check all functions.

MAGNETRON TEMPERATURE FUSE TEST

1. Disconnect the power supply cord, and then remove outer case.
2. Open the door and block it open.
3. To discharge high voltage capacitor, wait for 60 seconds.
4. A continuity check across the temperature fuse terminals should indicate a closed circuit. If the temperature of the magnetron reaches approximately 302°F(150°C), the temperature fuse opens. An open temperature fuse indicates overheating of the magnetron. Check for restricted air flow to the magnetron, especially the cooling fan air guide.
5. Reconnect all leads removed from components during testing.
6. Reinstall the outer case (cabinet).
7. Reconnect the power supply cord after the outer case is installed.
8. Run the oven and check all functions.

CAUTION: IF THE THERMAL CUT-OUT OR TEMPERATURE FUSE INDICATES AN OPEN CIRCUIT AT ROOM TEMPERATURE, REPLACE THERMAL CUT-OUT OR TEMPERATURE FUSE.

TEST PROCEDURES

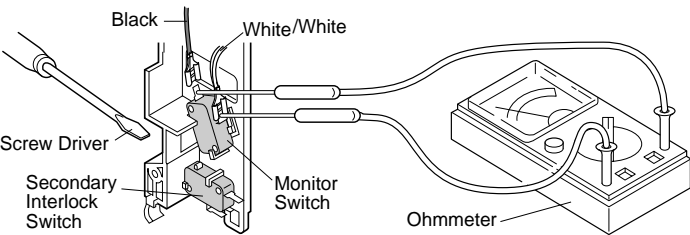
PROCEDURE LETTER	COMPONENT TEST
D	<p><u>PRIMARY INTERLOCK SWITCH AND SECONDARY INTERLOCK SWITCH TEST</u></p> <ol style="list-style-type: none"> 1. Disconnect the power supply cord, and then remove outer case. 2. Open the door and block it open. 3. To discharge high voltage capacitor, wait for 60 seconds. 4. Isolate the switch and connect the ohmmeter to the common (COM.) and normally open (NO) terminal of the switch. The meter should indicate an open circuit with the door open and a closed circuit with the door closed. If improper operation is indicated, replace the primary interlock switch or secondary interlock switch. 5. Reconnect all leads removed from components during testing. 6. Reinstall the outer case (cabinet). 7. Reconnect the power supply cord after the outer case is installed. 8. Run the oven and check all functions.
E	<p><u>STOP SWITCH TEST</u></p> <p><u>STOP SWITCH</u></p> <ol style="list-style-type: none"> 1. Disconnect the power supply cord, and then remove outer case. 2. Open the door and block it open. 3. To discharge high voltage capacitor, wait for 60 seconds. 4. Isolate the switch and connect the ohmmeter to the common (COM.) and normally open (NO) terminal of the switch. The meter should indicate an open circuit with the door open and a closed circuit with the door closed. If improper operation is indicated, replace the stop switch. 5. Reconnect all leads removed from components during testing. 6. Reinstall the outer case (cabinet). 7. Reconnect the power supply cord after the outer case is installed. 8. Run the oven and check all functions. <p>NOTE: If the stop switch contacts fail in the open position and the door is closed, the cooling fan motor, stirrer motor and oven light will be activated by RY1.</p>
F	<p><u>MONITOR SWITCH TEST</u></p> <ol style="list-style-type: none"> 1. Disconnect the power supply cord, and then remove outer case. 2. Open the door and block it open. 3. To discharge high voltage capacitor, wait for 60 seconds. 4. Before performing this test, make sure that the secondary interlock switch and the primary interlock switch are operating properly, according to the above Switch Test Procedure. Disconnect the wire lead from the monitor switch (COM) terminal. Check the monitor switch operation by using the ohmmeter as follows. When the door is open, the meter should indicate a closed circuit. When the monitor switch actuator is pushed by a screw driver through the lower latch hole on the front plate of the oven cavity with the door opened (in this condition the plunger of the monitor switch is pushed in), the meter should indicate an open circuit. If improper operation is indicated, the switch may be defective. After testing the monitor switch, reconnect the wire lead to the monitor switch (COM) terminal and check the continuity of the monitor circuit. 5. Reconnect all leads removed from components during testing. 6. Reinstall the outer case (cabinet). 7. Reconnect the power supply cord after the outer case is installed. 8. Run the oven and check all functions.
	 <p>The diagram illustrates the electrical setup for testing the monitor switch. It shows a cross-section of the oven door assembly. A screwdriver is shown pushing the actuator of the monitor switch through a hole in the front plate. The ohmmeter is connected to the Black and White/White terminals of the monitor switch. The Secondary Interlock Switch is also shown in the assembly.</p>
G	<p><u>BLOWN MONITOR FUSE TEST</u></p> <ol style="list-style-type: none"> 1. Disconnect the power supply cord, and then remove outer case. 2. Open the door and block it open.

TEST PROCEDURES

PROCEDURE LETTER	COMPONENT TEST
------------------	----------------

3. To discharge high voltage capacitor, wait for 60 seconds.
4. If the monitor fuse is blown when the door is opened, check the primary interlock switch, secondary interlock switch and monitor switch according to the "TEST PROCEDURE" for those switches before replacing the blown monitor fuse.

CAUTION: BEFORE REPLACING A BLOWN MONITOR FUSE, TEST THE PRIMARY INTERLOCK SWITCH, SECONDARY INTERLOCK SWITCH AND MONITOR SWITCH FOR PROPER OPERATION.

If the monitor fuse is blown by improper switch operation, the monitor fuse and monitor switch must be replaced with "monitor fuse and monitor switch assembly" part number FFS-BA016/KIT, even if the monitor switch operates normally. The monitor fuse and monitor switch assembly is comprised of a 20 ampere fuse and switch.

5. Reconnect all leads removed from components during testing.
6. Re-install the outer case (cabinet).
7. Reconnect the power supply cord after the outer case is installed.
8. Run the oven and check all functions.

H HOOD THERMAL CUT-OUT TEST

1. Disconnect the power supply cord, and then remove outer case.
2. Open the door and block it open.
3. To discharge high voltage capacitor, wait for 60 seconds.
4. A continuity check across the thermal cut-out terminals should indicate an open circuit unless the temperature of the thermal cut-out reaches approximately 140°F(60°C) or more. At that temperature, the contacts will close. The thermal cut-out opens automatically at approximately 113°F(45°C).
5. Reconnect all leads removed from components during testing.
6. Reinstall the outer case (cabinet).
7. Reconnect the power supply cord after the outer case is installed.
8. Run the oven and check all functions.

I HOOD FAN MOTOR TEST

1. Disconnect the power supply cord, and then remove outer case.
2. Open the door and block it open.
3. To discharge high voltage capacitor, wait for 60 seconds.
4. If the motor does not turn, touch the Fan Options pad once (set hood fan motor power "HIGH") and check voltage between pins "1" and "2" (Blue and Black wires) of the 6 pin connector. If 120 Volts appear and the hood capacitor is good, replace the hood fan assembly. If 120 Volts does not appear, check the motor circuit. The resistance values of motor terminals are as follows:
5. Reconnect all leads removed from components during testing.
6. Reinstall the outer case (cabinet).
7. Reconnect the power supply cord after the outer case is installed.
8. Run the oven and check all functions.

Resistance between:

- BLU (1) AND YLW (4) = 0Ω (Shorted)
- BLK (2) AND YLW (4) = 32Ω
- BLU (1) AND BLK (2) = 32Ω
- BLK (2) AND WHT (3) = 20Ω
- WHT (3) AND RED (5) = 45Ω

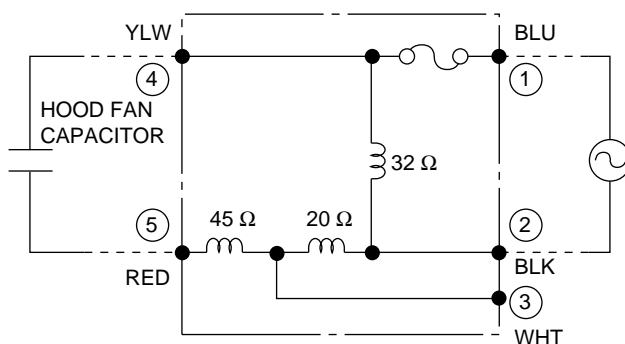

6-PIN CONNECTOR OF HOOD FAN MOTOR

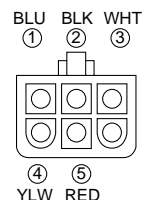

TEST PROCEDURES

PROCEDURE LETTER	COMPONENT TEST
J	<p><u>TOUCH CONTROL PANEL ASSEMBLY TEST</u></p> <p>The touch control panel consists of circuits including semiconductors such as LSI, ICs, etc. Therefore, unlike conventional microwave ovens, proper maintenance cannot be performed with only a voltmeter and ohmmeter. In this service manual, the touch control panel assembly is divided into two units, Control Unit and Key Unit, and also the Control Unit is divided into two units, LSI Unit and Power Unit, and troubleshooting by unit replacement is described according to the symptoms indicated.</p> <p>Before testing,</p> <ol style="list-style-type: none"> 1) Disconnect the power supply cord, and then remove outer case. 2) Open the door and block it open. 3) To discharge high voltage capacitor, wait for 60 seconds. 4) Disconnect the leads to the primary of the power transformer. 5) Ensure that these leads remain isolated from other components and oven chassis by using insulation tape. <p>1. Key Unit.</p> <p>NOTE ;</p> <ol style="list-style-type: none"> 1) Check Key unit ribbon connection before replacement. 2) Reconnect all leads removed from components during testing. 3) Re-install the outer case (cabinet). 4) Reconnect the power supply cord after the outer case is installed. 5) Run the oven and check all functions. <p>The following symptoms indicate a defective key unit.</p> <ol style="list-style-type: none"> a) When touching the pads, a certain pad produces no signal at all. b) When touching a number pad, two figures or more are displayed. c) When touching the pads, sometimes a pad produces no signal. <p>If the Key unit is defective.</p> <ol style="list-style-type: none"> 1) Disconnect the power supply cord, and then remove outer case. 2) Open the door and block it open. 3) To discharge high voltage capacitor, wait for 60 seconds. 4) Replace the Key unit. 5) Reconnect all leads removed from components during testing. 6) Re-install the outer case (cabinet). 7) Reconnect the power supply cord after the outer case is installed. 8) Run the oven and check all functions. <p>2. Control Unit</p> <p>The following symptoms indicate a defective control unit. Before replacing the control unit, perform the Key unit test (Procedure K) to determine if control unit is faulty.</p> <p>2-1 In connection with pads.</p> <ol style="list-style-type: none"> a) When touching the pads, a certain group of pads do not produce a signal. b) When touching the pads, no pads produce a signal. <p>2-2 In connection with indicators</p> <ol style="list-style-type: none"> a) At a certain digit, all or some segments do not light up. b) At a certain digit, brightness is low. c) Only one indicator does not light. d) The corresponding segments of all digits do not light up; or they continue to light up. e) Wrong figure appears. f) A certain group of indicators do not light up. g) The figure of all digits flicker. h) The following symptoms indicate a defective LSI unit. <ul style="list-style-type: none"> • When touching the keys on the touch screen, a certain key produces no signal at all. • When touching a number key on the touch screen, two figures or more are displayed. • When touching the keys on the touch screen, sometimes a key produces no signal. <p>2-3 Other possible problems caused by defective control unit.</p> <ol style="list-style-type: none"> a) Buzzer does not sound or continues to sound. b) Clock does not operate properly. c) Cooking is not possible. <p>When testing is completed,</p>

TEST PROCEDURES

PROCEDURE LETTER	COMPONENT TEST
	<ol style="list-style-type: none"> 1) Disconnect the power supply cord, and then remove outer case. 2) Open the door and block it open. 3) To discharge high voltage capacitor, wait for 60 seconds. 4) Reconnect all leads removed from components during testing. 5) Re-install the outer case (cabinet). 6) Reconnect the power supply cord after the outer case is installed. 7) Run the oven and check all functions.

K	KEY UNIT TEST																													
	<ol style="list-style-type: none"> 1. Disconnect the power supply cord, and then remove outer case. 2. Open the door and block it open. 3. To discharge high voltage capacitor, wait for 60 seconds. 4. If the display fails to clear when the STOP/CLEAR pad is depressed, first verify the flat ribbon cable is making good contact, verify that the stop switch operates properly; that is the contacts are closed when the door is closed and open when the door is open. If the stop switch is good, disconnect the flat ribbon cable that connects the key unit to the control unit and make sure the stop switch is closed (either close the door or short the stop switch connector). Use the Key unit matrix indicated on the control panel schematic and place a jumper wire between the pins that correspond to the STOP/CLEAR pad making momentary contact. If the control unit responds by clearing with a beep the key unit is faulty and must be replaced. If the control unit does not respond, it is faulty and must be replaced. If a specific pad does not respond, the above method may be used (after clearing the control unit) to determine if the control unit or key pad is at fault. 5. Reconnect all leads removed from components during testing. 6. Re-install the outer case (cabinet). 7. Reconnect the power supply cord after the outer case is installed. 8. Run the oven and check all functions. 																													
	<table border="1" style="margin-left: auto; margin-right: auto; border-collapse: collapse;"> <tr> <td style="border: none;">G 1</td><td style="border: none;">G 2</td><td style="border: none;">G 3</td><td style="border: none;">G 14</td></tr> <tr> <td style="border: none;">G 5</td><td>Baked Potatoes</td><td>Fish/Seafood</td><td>Fan Options</td><td>More from Your Microwave 6x6</td></tr> <tr> <td style="border: none;">G 6</td><td>Popcorn</td><td>Vegetables</td><td>Frozen Food</td><td>Defrost 3+6</td></tr> <tr> <td style="border: none;">G 13</td><td>Reheat</td><td>Meats</td><td>Set Up</td><td>Beverage Center</td></tr> <tr> <td style="border: none;">G 12</td><td>STOP/CLEAR</td><td>START</td><td>Turntable On/Off</td><td>Keep Warm</td></tr> <tr> <td style="border: none;">G 11</td><td>MINUTE PLUS</td><td>Poultry</td><td>Light Options</td><td>Pasta Grains</td></tr> </table>	G 1	G 2	G 3	G 14	G 5	Baked Potatoes	Fish/Seafood	Fan Options	More from Your Microwave 6x6	G 6	Popcorn	Vegetables	Frozen Food	Defrost 3+6	G 13	Reheat	Meats	Set Up	Beverage Center	G 12	STOP/CLEAR	START	Turntable On/Off	Keep Warm	G 11	MINUTE PLUS	Poultry	Light Options	Pasta Grains
G 1	G 2	G 3	G 14																											
G 5	Baked Potatoes	Fish/Seafood	Fan Options	More from Your Microwave 6x6																										
G 6	Popcorn	Vegetables	Frozen Food	Defrost 3+6																										
G 13	Reheat	Meats	Set Up	Beverage Center																										
G 12	STOP/CLEAR	START	Turntable On/Off	Keep Warm																										
G 11	MINUTE PLUS	Poultry	Light Options	Pasta Grains																										

L	RELAY TEST															
	<ol style="list-style-type: none"> 1. Disconnect the power supply cord, and then remove outer case. 2. Open the door and block it open. 3. To discharge high voltage capacitor. wait for 60 seconds. 4. Disconnect the leads to the primary of the power transformer. 5. Ensure that these leads remain isolated from other components and oven chassis by using insulation tape. 6. After that procedure, re-connect the power supply cord. 7. Remove the outer case and check voltage between Pin No. 5 of the 4 pin connector (A) and the common terminal of the relay RY1 on the control unit with an A.C. voltmeter. The meter should indicate 120 volts, if not check oven circuit. <p>RY1, RY2, RY3 and RY4 Relays Test</p> <p>These relays are operated by D.C. voltage</p> <p>Check voltage at the relay coil with a D.C. voltmeter during the microwave cooking operation.</p> <p style="padding-left: 40px;">DC. voltage indicated Defective relay.</p> <p style="padding-left: 40px;">DC. voltage not indicated Check diode which is connected to the relay coil. If diode is good, control unit is defective.</p> <table border="1" style="width: 100%; border-collapse: collapse; margin-top: 10px;"> <thead> <tr> <th style="width: 25%;">RELAY SYMBOL</th> <th style="width: 30%;">OPERATIONAL VOLTAGE</th> <th style="width: 45%;">CONNECTED COMPONENTS</th> </tr> </thead> <tbody> <tr> <td>RY1</td> <td>Approx. 25.6V D.C.</td> <td>Oven lamp / Stirrer motor / Cooling fan motor</td> </tr> <tr> <td>RY2</td> <td>Approx. 25.6V D.C.</td> <td>Turntable motor</td> </tr> <tr> <td>RY3</td> <td>Approx. 25.6V D.C.</td> <td>Hood motor</td> </tr> <tr> <td>RY4</td> <td>Approx. 25.6V D.C.</td> <td>Hood motor (HIGH/LOW selection)</td> </tr> </tbody> </table>	RELAY SYMBOL	OPERATIONAL VOLTAGE	CONNECTED COMPONENTS	RY1	Approx. 25.6V D.C.	Oven lamp / Stirrer motor / Cooling fan motor	RY2	Approx. 25.6V D.C.	Turntable motor	RY3	Approx. 25.6V D.C.	Hood motor	RY4	Approx. 25.6V D.C.	Hood motor (HIGH/LOW selection)
RELAY SYMBOL	OPERATIONAL VOLTAGE	CONNECTED COMPONENTS														
RY1	Approx. 25.6V D.C.	Oven lamp / Stirrer motor / Cooling fan motor														
RY2	Approx. 25.6V D.C.	Turntable motor														
RY3	Approx. 25.6V D.C.	Hood motor														
RY4	Approx. 25.6V D.C.	Hood motor (HIGH/LOW selection)														

8. Disconnect power supply cord, and then remove outer case.

TEST PROCEDURES

PROCEDURE LETTER	COMPONENT TEST
------------------	----------------

9. Open the door and block it open.
10. To discharge high voltage capacitor, wait for 60 seconds.
11. Reconnect all leads removed from components during testing.
12. Re-install the outer case (cabinet).
13. Reconnect the power supply cord after the outer case is installed.
14. Run the oven and check all functions.

M **COMPU DEFROST TEST**

WARNING : The oven should be fully assembled before following procedure.

- (1) Place one cup of water in the center of the turntable tray in the oven cavity.
- (2) Close the door, touch the Defrost pad and select compu Defrost. Then select Steaks/Chops/Fish. (Now, weight 0.5lb is set.) And then touch the start pad.
- (3) The oven is in Compu Defrost cooking condition.
- (4) The oven will operate as follows

WEIGHT	1ST STAGE		2ND STAGE	
0.5lb	LEVEL	TIME	LEVEL	TIME
	70%	30sec.	40%	25sec.

- (5) If improper operation is indicated, the control unit is probably defective and should be checked.

N **FOIL PATTERN ON THE PRINTED WIRING BOARD TEST**

To protect the electronic circuits, this model is provided with a fine foil pattern added to the primary on the PWB, this foil pattern acts as a fuse.

1. Foil pattern check and repairs.
 - 1) Disconnect the power supply cord, and then remove outer case.
 - 2) Open the door and block it open.
 - 3) To discharge high voltage capacitor, wait for 60 seconds.
 - 4) Follow the troubleshooting guide given below for repair.

STEPS	OCCURRENCE	CAUSE OR CORRECTION
1	Only pattern at "a" is broken.	*Insert jumper wire J1 and solder.
2	Pattern at "a" and "b" are broken.	*Insert the coil RCILF2003YAZZ between "c" and "d".

- 5) Make a visual inspection of the varistor. Check for burned damage and examine the transformer with a tester for the presence of layer short-circuit (check the primary coil resistance which is approximately $138\Omega \pm 10\%$). If any abnormal condition is detected, replace the defective parts.

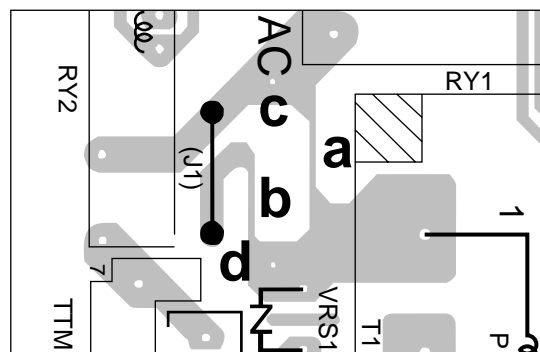

- 6) Reconnect all leads removed from components during testing.
 - 7) Re-install the outer case (cabinet).
 - 8) Reconnect the power supply cord after the outer case is installed.
 - 9) Run the oven and check all functions.
2. Follow the troubleshooting guide given below, if indicator does not light up after above check and repairs are finished.
 - 1) Disconnect the power supply cord, and then remove outer case.
 - 2) Open the door and block it open.
 - 3) To discharge high voltage capacitor, wait for 60 seconds.
 - 4) Disconnect the leads to the primary of the power transformer.
 - 5) Ensure that these leads remain isolated from other components and oven chassis by using insulation tape.

TEST PROCEDURES

PROCEDURE LETTER	COMPONENT TEST
------------------	----------------

- 6) After that procedure, re-connect the power supply cord.
- 7) Follow the troubleshooting guide given below for repair.

STEPS	OCCURRENCE	CAUSE OR CORRECTION
1	The rated AC voltage is not present between Pin No. 5 of the 4-pin connector (A) and the common terminal of the relay RY1.	Check supply voltage and oven power cord.
2	The rated AC voltage is present at primary side of low voltage transformer.	Low voltage transformer or secondary circuit defective. Check and repair.

- 8) Disconnect the power supply cord, and then remove outer case.
- 9) Open the door and block it open.
- 10) To discharge high voltage capacitor, wait for 60 seconds.
- 11) Reconnect all leads removed from components during testing.
- 12) Re-install the outer case (cabinet).
- 13) Reconnect the power supply cord after the outer case is installed.
- 14) Run the oven and check all functions.

O AH SENSOR TEST

Checking the initial sensor cooking condition

WARNING : The oven should be fully assembled before following procedure.

- (1) The oven should be plugged in at least two minutes before sensor cooking.
- (2) Room temperature should not exceed 95°F (35°C).
- (3) The unit should not be installed in any area where heat and steam are generated. The unit should not be installed, for example, next to a conventional surface unit. Refer to the "INSTALLATION INSTRUCTIONS" of the operation manual.
- (4) Exhaust vents are provided on the back of the unit for proper cooling and air flow in the cavity. To permit adequate ventilation, be sure to install so as not to block these vents. There should be some space for air circulation.
- (5) Be sure the exterior of the cooking container and the interior of the oven are dry. Wipe off any moisture with a dry cloth or paper towel.
- (6) The Sensor works with food at normal storage temperature. For example, chicken pieces would be at refrigerator temperature and canned soup at room temperature.
- (7) Avoid using aerosol sprays or cleaning solvents near the oven while using Sensor settings. The sensor will detect the vapor given off by the spray and turn off before food is properly cooked.
- (8) If the sensor has not detected the vapor of the food, ERROR will appear and the oven will shut off.

Water load cooking test

WARNING : The oven should be fully assembled before following procedure.

Make sure the oven has been plugged in at least two minutes before checking sensor cook operation. The cabinet should be installed and screws tightened.

- (1) Fill approximately 200 milliliters (7.2 oz) of tap water in a 1000 milliliter measuring cup.
- (2) Place the container on the center of tray in the oven cavity.
- (3) Close the door.
- (4) Touch Reheat pad. Then select "Regular Turntable On". And touch START pad. Now, the oven is in the sensor cooking condition and "SENSING" will appear.
- (5) The oven will operate for the first 32 seconds, without generating microwave energy.

NOTE: ERROR will appear if the door is opened or STOP/CLEAR pad is touched during first stage of sensor cooking.

- (6) After approximately 16 seconds, microwave energy is produced, and the display should start to count down the remaining cooking time and oven should turn off after water is boiling (bubbling). If the oven does not turn off, replace the AH sensor or check the control unit, refer to explanation below.

TESTING METHOD FOR AH SENSOR AND/OR CONTROL UNIT

To determine if the sensor is defective, the simplest method is to replace it with a new replacement sensor.

- (1) Disconnect the power supply cord, and then remove outer case.
- (2) Open the door and block it open.
- (3) To discharge high voltage capacitor, wait for 60 seconds.

TEST PROCEDURES

PROCEDURE LETTER	COMPONENT TEST
	<p>(4) Remove the AH sensor.</p> <p>(5) Install the new AH sensor.</p> <p>(6) Reconnect all leads removed from components during testing.</p> <p>(7) Re-install the outer case (cabinet).</p> <p>(8) Reconnect the power supply cord after the outer case is installed.</p> <p>(9) Reconnect the oven to the power supply and check the sensor cook operation as follows:</p> <p style="padding-left: 20px;">9-1. Fill approximately 200 milliliters (7.2 oz) of tap water in a 1000 milliliter measuring cup.</p> <p style="padding-left: 20px;">9-2. Place the container on the center of tray in the oven cavity.</p> <p style="padding-left: 20px;">9-3. Close the door.</p> <p style="padding-left: 20px;">9-4. Touch Reheat pad. Then select "Regular Turntable On". And touch START pad.</p> <p style="padding-left: 20px;">9-5. The control panel is in automatic Sensor operation.</p> <p style="padding-left: 20px;">9-6. The display will start to count down the remaining cooking time, and the oven will turn off automatically after the water is boiling (bubbling).</p> <p>If new sensor dose not operate properly, the problem is with the control unit, and refer to explanation below.</p>

CHECKING CONTROL UNIT

- (1) Disconnect the power supply cord, and then remove outer case.
- (2) Open the door and block it open.
- (3) To discharge high voltage capacitor, wait for 60 seconds.
- (4) Disconnect the sensor connector that is mounted to control panel.
- (5) Then connect the dummy resistor circuit (see fig. below) to the sensor connector of control panel.
- (6) Disconnect the connector of the main wire harness from the inverter wire assembly connected to the inverter unit.
- (7) Ensure that the connector remain isolated from other components and oven chassis by using insulation tape.
- (8) After that procedure, re-connect the power supply cord.
- (9) Check the sensor cook operation proceed as follows:
 - 9-1. Touch Reheat pad. Then select "Regular Turntable On". And touch START pad.
 - 9-2. The control panel is in the sensor cooking operation.
 - 9-3. After approximately 70 seconds, push plunger of select switch for more than 3 seconds. This condition is same as judgement by AH sensor.
 - 9-4. After approximately 3 seconds, the display shows " X X . X X " which is the remaining cooking time, and the display counts down.

If the above is not the case, the control unit is probably defective.
If the above is indicated, the AH sensor is probably defective.
- (10) Disconnect the power supply cord, and then remove outer case.
- (11) Open the door and block it open.
- (12) To discharge high voltage capacitor, wait for 60 seconds.
- (13) Disconnect the dummy resistor circuit from the sensor connector of control panel.
- (14) Carry out necessary repair.
- (15) Reconnect all leads removed from components during testing and repairing.
- (16) Re-install the outer case (cabinet).
- (17) Reconnect the power supply cord after the outer case is installed. Run the oven and check all functions.
- (18) Carry out "Water load cooking test" again and ensure that the oven works properly.

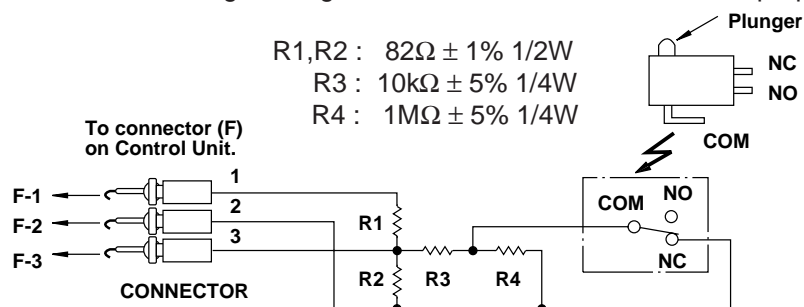

Sensor Dummy Resistor Circuit

TOUCH CONTROL PANEL ASSEMBLY

OUTLINE OF TOUCH CONTROL PANEL

The touch control section consists of the following units.

- (1) Key Unit
- (2) Control Unit (The Control Unit consists of Power Unit and LSI Unit).

The principal functions of these units and the signals communicated among them are explained below.

Key Unit

The key unit is composed of a matrix, signals generated in the LSI are sent to the key unit through P93, P94, P95 and P40.

When a key pad is touched, a signal is completed through the key unit and passed back to the LSI through PB1, PB2, PB3, PB4 and PB5 to perform the function that was requested.

Control Unit

Control unit consists of LSI, IC, ACL circuit, inverter unit control circuit, indicator circuit, power source circuit, relay circuit, buzzer circuit, synchronizing signal circuit, key unit circuit, touch screen circuit, absolute humidity sensor circuit and back light circuit.

1) IC1 (LSI)

This is a microcomputer, responsible for controlling the entire control unit.

2) IC2

This is a read only memory IC, responsible for giving IC1 the all programmes.

3) IC3

This is an amplifier IC. This IC controls the contrast of LCD and amplify the sensor signal.

4) IC4

This is a memory IC. This memorizes the contrast of LCD.

5) IC5

This IC drives the LCD.

6) ACL

This circuit generates a signal which resets the LSI (IC1) to the initial state when power is supplied.

7) Indicator Circuit

This circuit consists of 100 x 160 dots using a Liquid Crystal Display. The Liquid Crystal Display (LCD) is driven by IC5.

8) Power Source Circuit

This circuit generates voltages necessary in the control unit from the AC line voltage.

In addition, the synchronizing signal is available in order to compose a basic standard time in the clock circuit.

Symbol	Voltage	Application
VC	+5V	LSI(IC1)

9) Relay Circuit

A circuit to drive the fan motor, stirrer motor, turntable motor, hood motor and light the oven lamp.

10) Buzzer Circuit

The buzzer is responsive to signals from the LSI to emit audible sounds (key touch sound and completion sound).

11) Synchronizing Signal Circuit

The power source synchronizing signal is available in order to compose a basic standard time in the clock circuit.

It accompanies a very small error because it works on commercial frequency.

12) Stop Switch

A switch to "tell" the LSI if the door is open or closed.

13) Back Light Circuit

A circuit to drive the back light (Light emitting diodes LED1 and LED2).

14) Absolute Humidity Sensor Circuit

This circuit detects moisture of the cooking food to allow its automatic cooking.

15) Touch Screen

The touch screen is composed of a matrix, signal generated in the LSI are sent to the key unit through P41, P42, P43 and P44. When a key is touched, a signal is completed through the touch screen and passed back to the LSI through PB1, PB2, PB3, PB4 and PB5 to perform the function that was requested.



16) Inverter Unit Control Circuit

This is the circuit to control the inverter unit.

DESCRIPTION OF LSI

LSI(IZA958DR)

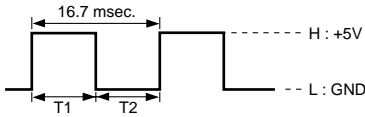
The I/O signal of the LSI(IZA958DR) is detailed in the following table.

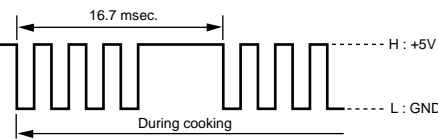
Pin No.	Signal	I/O	Description
1	TIOCA2	OUT	<p>Power level data output signal for inverter unit. The power level will be decided by the time ratio of T1 and T2.</p> 
2	A20	OUT	Terminal not used.
3	Vcc	IN	<p>Power source voltage : +5.0V. The power source voltage to drive LSI is input to Vcc terminal. Connected to Vcc.</p>
4	TMO0	OUT	<p>Signal to sound buzzer. A: key touch sound (short beep). B: Completion sound (melody or long beep).</p>
5	PB1	IN	<p>Signal coming from touch key. When either G11 line on key matrix is touched, a corresponding signal out of P93, P94, P95, P40, P41, P42, P43 and P44 will be input into PB1. When no key is touched, the signal is held at "H" level.</p>
6	PB2	IN	<p>Signal similar to PB1. When either G12 line on key matrix is touched, a corresponding signal will be input into PB2.</p>
7	PB3	IN	<p>Signal similar to PB1. When either G13 line on key matrix is touched, a corresponding signal will be input into PB3.</p>
8	PB4	IN	<p>Signal similar to PB1. When either G6 line on key matrix is touched, a corresponding signal will be input into PB4.</p>
9	PB5	IN	<p>Signal similar to PB1. When either G5 line on key matrix is touched, a corresponding signal will be input into PB5.</p>
10	PB6	OUT	Terminal not used. Connected to test point.
11	PB7	OUT	<p>Turntable motor driving signal. To turn on and off relay(RY2). "H" level: During Turntable On. "L" level: During Turntable OFF or during the oven is off condition.</p> 
12	RESO	OUT	Terminal not used.
13	Vss	IN	<p>Power source voltage: GND(0V). The power source voltage to drive LSI is input to Vss terminal.</p>
14	TxD0	OUT	Data signal is output to a memory IC (IC4).
15	P91	OUT	Clock signal is output to a memory IC (IC4).
16	RxD0	OUT	<p>Oven lamp, fan motor and stirrer motor driving signal To turn on and off shut off relay (RY1). The square wave voltage is delivered to the RY1 driving circuit.</p> 
17	P93	OUT	<p>Key strobe signal. Signal applied to key unit section. A pulse signal is input to PB1-PB5 terminal while one of G1 line keys on key matrix is touched.</p>
18	P94	OUT	<p>Key strobe signal. Signal applied to key unit section. A pulse signal is input to PB1-PB5 terminal while one of G2 line keys on key matrix is touched.</p>
19	P95	OUT	<p>Key strobe signal. Signal applied to key unit section. A pulse signal is input to PB1-PB5 terminal while one of G3 line keys on key matrix is touched.</p>
20	P40	OUT	<p>Key strobe signal. Signal applied to key unit section. A pulse signal is input to PB1-PB5 terminal while one of G14 line keys on key matrix is touched.</p>

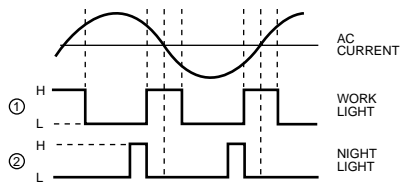
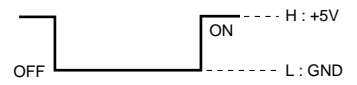
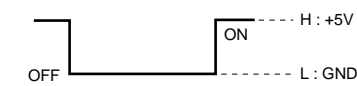
Pin No.	Signal	I/O	Description
21	P41	OUT	Key strobe signal. Signal applied to touch screen section. A pulse signal is input to PB1-PB5 terminal while one of G7 line keys on key matrix is touched.
22	P42	OUT	Key strobe signal. Signal applied to touch screen section. A pulse signal is input to PB1-PB5 terminal while one of G8 line keys on key matrix is touched.
23	P43	OUT	Key strobe signal. Signal applied to touch screen section. A pulse signal is input to PB1-PB5 terminal while one of G9 line keys on key matrix is touched.
24	Vss	IN	Power source voltage : GND(0V). The power source voltage to drive LSI is input to VSS terminal.
25	P44	OUT	Key strobe signal. Signal applied to touch screen section. A pulse signal is input to PB1-PB5 terminal while one of G10 line keys on key matrix is touched.
26	P45	OUT	Hood lamp driving signal. To turn on and off solid state relay (SSR1). "①" level : During Hood lamp ON (WORK LIGHT level). "②" level: During Hood lamp ON (NIGHT LIGHT level) . "H" level: During Hood lamp ON. 
27	P46	OUT	Hood motor driving signal. To turn on and off relay (RY3). "H" level : During Hood motor ON. "L" level: During Hood Imotor OFF. 
28	P47	OUT	Hood motor high / low driving signal. To turn on and off relay (RY4). "H" level : During Hood motor high. "L" level: During Hood Imotor low. 
29-36	D8-D15	OUT	Data signal is output to IC2 and IC5.
37	Vcc	IN	Power source voltage : +5V. The power source voltage to drive LSI is input to Vcc terminal. Connected to VCC.
38-45	A0-A7	OUT	Address signal is output to IC2 and IC5.
46	Vss	IN	Power source voltage : GND (0V). The power source voltage to drive LSI is input to Vss terminal.
47-58	A8-A19	OUT	Address signal is output to IC2 and IC5.
59	Vss	IN	Power source voltage : GND (0V). The power source voltage to drive LSI is input to Vss terminal.
60	WATT	IN	Connected to VCC.
61	P61	OUT	Envelope signal to sound buzzer. A: key touch sound (short beep). B: Completion sound (melody or long beep).
62	P62	OUT	Reset signal is output to IC5.
63	P67	OUT	Terminal not used.
64	STBY	IN	Connected to VCC.
65	RES	IN	Auto clear terminal. Signal is input to reset the LSI to the initial state when power is applied. Temporarily set "L" level the moment power is applied, at this time the LSI is reset. Thereafter set at "H" level.
66	NMI	IN	Connected to GND.
67	Vss	IN	Power source voltage : GND (0V). The power source voltage to drive LSI is input to Vss terminal.
68	EXTAL	OUT	Internal clock oscillation output. Output to control oscillation input to EXTAL.

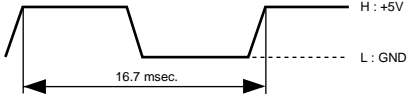
Pin No.	Signal	I/O	Description
69	XTAL	IN	Internal clock oscillation frequency control input setting. The internal clock frequency is set by inserting the ceramic filter oscillation circuit with respect to XTAL.
70	Vcc	IN	Power source voltage : +5V. The power source voltage to drive LSI is input to Vcc terminal. Connected to VCC.
71	AS	OUT	Terminal not used.
72	RD	OUT	Read strobe signal is output to RD terminal of IC5.
73	HWR	OUT	Write strobe signal is output to WR terminal of IC5.
74	LWR	OUT	Terminal not used.
75-76	MD0-MD1	IN	Connected to VCC.
77	MD2	IN	Connected to GND.
78	Avcc	IN	A/D converter power source voltage : +5V. The power source voltage to drive the A/D converter. Connected to VCC.
79	Vref	IN	A/D converter power source voltage : +5V. The power source voltage to drive the A/D converter. Connected to VCC.
80	AN0	IN	When a magnetron generates abnormally the detecting signal is input to AN0 terminal.
81	AN1	IN	To input signal which communicates the door open/close information to LSI. Door close "L" level signal (GND). Door open "H" level signal (+5V).
82	AN2	IN	Terminal to change cooking input according to the model. By using the A/D converter contained in the LSI, DC voltage in accordance with the Model in operation is applied to set up its cooking constant.
83	AN3	IN	Terminal to judge whether the model has the sensor cooking function or not. By using the A/D converter contained in the LSI, DC voltage in accordance with the Model in operation is applied to judge whether the model has the sensor cooking function or not.
84	AN4	IN	AH sensor input. This input is an analog input terminal from the AH sensor circuit, and connected to the A/D converter built into the LSI.
85	AN5	IN	Used for initial balancing of the bridge circuit (absolute humidity sensor). This input is an analog input terminal from the AH sensor circuit, and connected to the A/D converter built into the LSI.
86	DA0	OUT	Terminal not used.
87	DA1	OUT	The signal for the power source to drive the LCD is output to IC3.
88	Avss	IN	A/D converter power source voltage : GND(0V). The power source voltage to drive the A/D converter. Connected to GND.
89	IRQ0	IN	Signal synchronized with commercial power source frequency. This is the basic timing for time processing of LSI. 
90-91	P81-P82	OUT	Terminal not used.
92	CS1	OUT	Chip select signal is output to CS terminal of IC5.
93	CS0	OUT	Chip select signal is output to CE terminal of IC2.
94	Vss	IN	Power source voltage : GND (0V). The power source voltage to drive the LSI is input to Vss terminal.
95-99	PA0-PA4	OUT	Used for initial balancing of the bridge circuit (absolute humidity sensor).
100	PA5	OUT	Clock signal is output to IC5.

ABSOLUTE HUMIDITY SENSOR CIRCUIT

(1) Structure of Absolute Humidity Sensor

The absolute humidity sensor includes two thermistors as shown in the illustration. One thermistor is housed in the closed vessel filled with dry air while another in the open vessel. Each sensor is provided with the protective cover made of metal mesh to be protected from the external airflow.

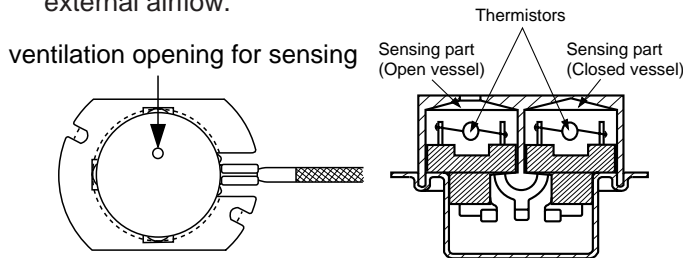

(2) Operational Principle of Absolute Humidity Sensor

The figure below shows the basic structure of an absolute humidity sensor. A bridge circuit is formed by two thermistors and two resistors (R1 and R2).

The output of the bridge circuit is to be amplified by the operational amplifier.

Each thermistor is supplied with a current to keep it heated at about 150°C (302°F), the resultant heat is dissipated in the air and if the two thermistors are placed in different humidity conditions they show different degrees of heat conductivity leading to a potential difference between them causing an output voltage from the bridge circuit, the intensity of which is increased as the absolute humidity of the air increases. Since the output is very minute, it is amplified by the operational amplifier.

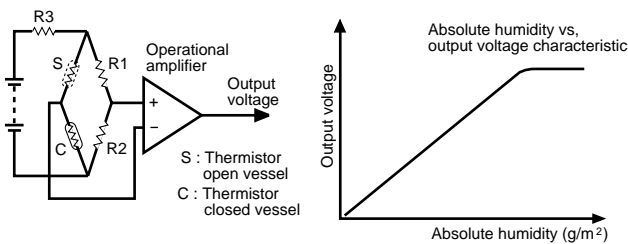

(3) Detector Circuit of Absolute Humidity Sensor Circuit

This detector circuit is used to detect the output voltage of the absolute humidity circuit to allow the LSI to control sensor cooking of the unit. When the unit is set in the sensor cooking mode, 32 seconds clearing cycle occurs than the detector circuit starts to function and the LSI observes the initial voltage available at its AN4 terminal. With this voltage given, the switches SW1 to SW5 in the LSI are turned on in such a way as to change the resistance values in parallel with R47 ~ R52. Changing the resistance values results in that there is the same potential at both F-3 terminal of the absolute humidity sensor and AN5 terminal of the LSI. The voltage of AN4 terminal will indicate about +2.5V. This initial balancing is set up about 32 seconds after the unit is put in the Sensor Cooking mode. As the sensor cooking proceeds, the food is heated to generate moisture by which the

resistance balance of the bridge circuit is deviated to increase the voltage available at AN4 terminal of the LSI. Then the LSI observes that voltage at AN4 terminal and compares it with its initial value, and when the comparison rate reaches the preset value (fixed for each menu to be cooked), the LSI causes the unit to stop sensor cooking; thereafter, the unit goes in the next operation automatically.

When the LSI starts to detect the initial voltage at AN4 terminal 32 seconds after the unit has been put in the Sensor Cooking mode, if it is not possible to balance the bridge circuit due to disconnection of the absolute humidity sensor, ERROR will appear on the display and the cooking is stopped.

1) Absolute humidity sensor circuit

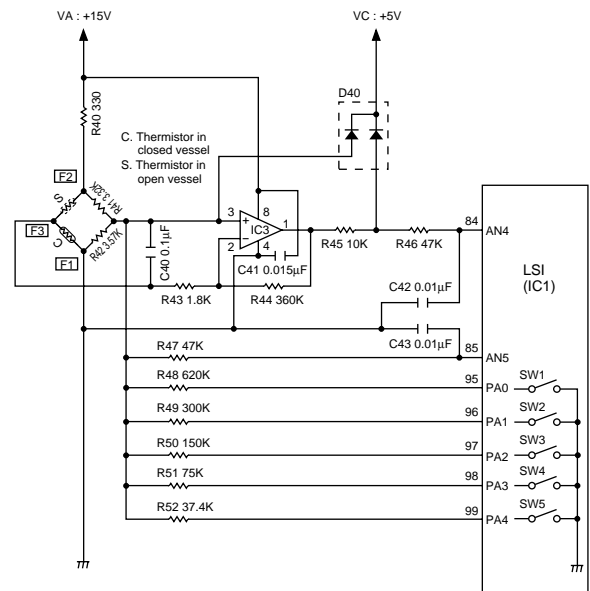

SERVICING

1. Precautions for Handling Electronic Components

This unit uses CMOS LSI in the integral part of the circuits. When handling these parts, the following precautions should be strictly followed. CMOS LSI have extremely high impedance at its input and output terminals. For this reason, it is easily influenced by the surrounding high voltage power source, static electricity charge in clothes, etc. and sometimes it is not fully protected by the built-in protection circuit.

In order to protect CMOS LSI.

- 1) When storing and transporting, thoroughly wrap them in aluminium foil. Also wrap all PW boards containing them in aluminium foil.
- 2) When soldering, ground the technician as shown in the figure and use grounded soldering iron and work table.

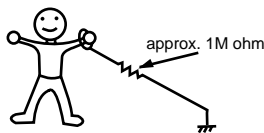

2. Shapes of Electronic Components

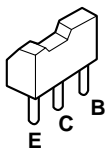

Transistor
2SD1859

3. Servicing of Touch Control Panel

We describe the procedures to permit servicing of the touch control panel of the microwave oven and the precautions you must take when doing so. To perform the servicing, power to the touch control panel is available either from the power line of the oven itself or from an external power source.

(1) Servicing the touch control panel with power supply of the oven:

CAUTION:

THE HIGH VOLTAGE TRANSFORMER OF THE MICROWAVE OVEN IS STILL LIVE DURING SERVICING AND PRESENTS A HAZARD.

Therefore, before checking the performance of the touch control panel,

- 1) Disconnect the power supply cord, and then remove outer case.
- 2) Open the door and block it open.
- 3) Discharge high voltage capacitor.
- 4) Disconnect the leads to the primary of the power transformer.
- 5) Ensure that these leads remain isolated from other components and oven chassis by using insulation tape.
- 6) After that procedure, re-connect the power supply cord.

After checking the performance of the touch control panel,

- 1) Disconnect the power supply cord.
- 2) Open the door and block it open.
- 3) Re-connect the leads to the primary of the power transformer.

- 4) Re-install the outer case (cabinet).
- 5) Re-connect the power supply cord after the outer case is installed.
- 6) Run the oven and check all functions.

A. On some models, the power supply cord between the touch control panel and the oven itself is so short that the two can't be separated. For those models, check and repair all the controls (sensor-related ones included) of the touch control panel while keeping it connected to the oven.

B. On some models, the power supply cord between the touch control panel and the oven proper is long enough that they may be separated from each other. For those models, it is possible to check and repair the controls of the touch control panel while keeping it apart from the oven proper; in this case you must short both ends of the stop switch (on PWB) of the touch control panel with a jumper, which activates an operational state that is equivalent to the oven door being closed. As for the sensor-related controls of the touch control panel, checking them is possible if dummy resistor(s) with resistance equal to that of the controls are used.

(2) Servicing the touch control panel with power supply from an external power source:

Disconnect the touch control panel completely from the oven proper, and short both ends of the stop switch (on PWB) of the touch control panel, which activates an operational state that is equivalent to the oven door being closed. Connect an external power source to the power input terminal of the touch control panel, then it is possible to check and repair the controls of the touch control panel it is also possible to check the sensor-related controls of the touch control panel by using the dummy resistor(s).

4. Servicing Tools

Tools required to service the touch control panel assembly.

- 1) Soldering iron: 30W
(It is recommended to use a soldering iron with a grounding terminal.)
- 2) Oscilloscope: Single beam, frequency range: DC-10MHz type or more advanced model.
- 3) Others: Hand tools

5. Other Precautions

- 1) Before turning on the power source of the control unit, remove the aluminium foil applied for preventing static electricity.
- 2) Connect the connectors of the key unit to the control unit being sure that the lead wires are not twisted.
- 3) After aluminium foil is removed, be careful that abnormal voltage due to static electricity etc. is not applied to the input or output terminals.
- 4) Attach connectors, electrolytic capacitors, etc. to PWB, making sure that all connections are tight.
- 5) Be sure to use specified components where high precision is required.

COMPONENT REPLACEMENT AND ADJUSTMENT PROCEDURE

WARNING AGAINST HIGH VOLTAGE:

Microwave ovens contain circuitry capable of producing very high voltage and current, contact with following parts may result in severe, possibly fatal, electric shock.

(Example)

Inverter unit that includes High Voltage Capacitor, Power Transformer, High Voltage Rectifier and Heat sink etc., and Magnetron, High Voltage Harness etc..

WARNING: Avoid possible exposure to microwave energy. Please follow the instructions below before operating the oven.

- | | |
|--|--|
| <ol style="list-style-type: none"> 1. Disconnect the power supply cord. 2. Visually check the door and cavity face plate for damage (dents, cracks, signs of arcing etc.). | <ol style="list-style-type: none"> 4. The door is bent or warped. 5. There are defective parts in the door interlock system. 6. There are defective parts in the microwave generating and transmission assembly. 7. There is visible damage to the oven. |
|--|--|

Carry out any remedial work that is necessary before operating the oven.

Do not operate the oven if any of the following conditions exist;

1. Door does not close firmly.
2. Door hinge, support or latch hook is damaged.
3. The door gasket or seal is damaged.

Do not operate the oven:

1. Without the RF gasket (Magnetron).
2. If the wave guide or oven cavity are not intact.
3. If the door is not closed.
4. If the outer case (cabinet) is not fitted.

WARNING FOR WIRING

To prevent an electric shock, take the following precautions.

- | | |
|---|---|
| <ol style="list-style-type: none"> 1. Before wiring, <ol style="list-style-type: none"> 1) Disconnect the power supply cord. 2) Open the door block it open. 3) To discharge high voltage capacitor, wait for 60 seconds. 2. Don't let the wire leads touch to the following parts; <ol style="list-style-type: none"> 1) High voltage parts: Magnetron, Inverter unit. 2) Hot parts: Oven lamp, Magnetron, Inverter unit and Oven cavity. | <ol style="list-style-type: none"> 3) Sharp edge: Bottom plate, Oven cavity, Waveguide flange, Chassis support and other metallic plate. 4) Movable parts (to prevent a fault) Fan blade, Fan motor, Switch, Stirrer motor, Stirrer fan. 3) Do not catch the wire leads in the outer case cabinet. 4. Insert the positive lock connector until its pin is locked and make sure that the wire leads do not come off even if the wire leads are pulled. 5. To prevent an error function, connect the wire leads correctly, referring to the Pictorial Diagram. |
|---|---|

Please refer to 'OVEN PARTS, CABINET PARTS, CONTROL PANAL PARTS, DOOR PARTS', when carrying out any of the following removal procedures:

THE FOLLOWING ADJUSTMENTS OR COMPONENT REPLACEMENT CAN BE PERFORMED WITHOUT REMOVING THE OVEN FROM THE WALL

- | | |
|--|---|
| <ol style="list-style-type: none"> 1. Hood lamps, sockets and grease filter. 2. Oven lamp, base cover and hood lamp glass assembly. 3. Turntable motor. | <ol style="list-style-type: none"> 4. Hood exhaust louver. 5. Control panel assembly or components 6. Stirrer cover and stirrer fan. |
|--|---|

HOOD EXHAUST LOUVER REMOVAL

- | | |
|---|--|
| <ol style="list-style-type: none"> 1. Disconnect the power supply cord. 2. Open the door and block it open. 3. Remove the one (1) screw holding the hood exhaust louver to the oven cavity with the outer case cabinet. 4. Pull the hood exhaust louver from the oven cavity by pushing the right and left tabs of the hood exhaust louver to remove. | <ol style="list-style-type: none"> 5. Now, the hood exhaust louver is free. |
|---|--|

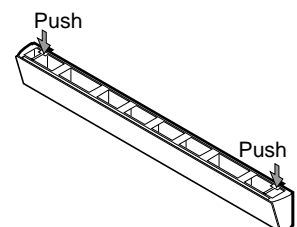

REMOVAL OF OVEN FROM WALL (It is recommended that two people remove the oven)

1. Disconnect the power supply cord, and uncoil the power supply cord.
2. Remove the turntable tray and support from the oven cavity.
3. Remove the one (1) screw holding the exhaust damper assembly to the rear stay, and remove the exhaust damper assembly by sliding it backward.
4. Remove the two (2) screws holding the oven (outer case cabinet) to the top cabinet.
5. Remove the hood exhaust louver referring to "HOOD EXHAUST LOUVER REMOVAL".
6. While supporting the front of the oven, unfasten the two (2) unit mounting screws holding the oven to the unit mounting plate.
7. Remove the oven by sliding it into the arms of the unit mounting plate and pull the power cord out of the wall cabinet.
8. The oven is now free and can be placed on the work surface selected for servicing the oven.
9. Installation is the reverse of this procedure.

OUTER CASE REMOVAL

Remove the oven from the wall and proceed as follows;

1. Disconnect the power supply cord.
2. Open the door and block it open.
3. Remove one (1) screw holding the hood exhaust louver to the oven, and pull it forward to remove by pushing the right and left tabs of the hood exhaust louver. (Refer to procedure of "HOOD EXHAUST LOUVER REMOVAL".)
4. Remove four (4) screws holding the rear stay to the hood fan motor or the oven, and remove it.
5. Remove the four (4) screws from the rear of the outer case cabinet.
6. Slide the outer case cabinet back about 1 inch (3 cm) to

free it from retaining clips on the cavity face plate.

7. Disconnect the three (3) pin connector of the power supply cord from the wiring harness and remove the power supply cord together with the outer case.
8. Discharge high voltage capacitor.

CAUTION: 1. DISCONNECT OVEN FROM POWER SUPPLY BEFORE REMOVING OUTER CASE.

2. DISCHARGE THE HIGH VOLTAGE CAPACITOR BEFORE TOUCHING ANY OVEN COMPONENTS OR WIRING.

INVERTER UNIT REMOVAL

1. Disconnect the power supply cord, remove the oven from wall, and remove outer case. (Refer to procedure of "Removal of Oven from Wall" and "Outer Case Removal".) And proceed as follows.
2. Open the door and block it open.
3. To discharge high voltage capacitor, wait for 60 seconds.
4. Remove the three (3) screws holding the base cover to the oven cavity.
5. Open the base cover from the oven cavity by pulling down.
6. Remove the two (2) screws holding the inverter angle to the right base plate.
7. Remove one (1) screw holding the hood duct to the oven cavity front flange.
8. Disconnect the stop switch harness from the chassis support and disconnect the wire leads from the fan motor.
9. Lift up the fan motor side of the hood duct.
10. Disconnect the high voltage wire from the magnetron.
11. Release the inverter angle from the right base plate.
12. Disconnect high voltage wire assembly and the inverter wire assembly from the inverter unit.
13. Remove the three (3) screws holding the inverter unit to the inverter angle.
14. Remove the inverter unit from the inverter angle.

3. Install by sliding the inverter angle on the right base plate.
4. Secure the inverter angle with two (2) screws to right base plate.
5. Reinstall the base cover to the oven cavity with the three (3) screws.
6. Re-connect high voltage wire assembly to the magnetron. Refer to "PICTORIAL DIAGRAM".
7. Re-install the hood duct holding the fan motor to the oven cavity front flange with one (1) screw.
8. Re-connect the wire leads to the chassis support and the fan motor, referring to "PICTORIAL DIAGRAM".
9. Re-install the outer case and check that oven is operating properly.

CAUTION: MAKE SURE THE WIRE LEADS NEVER TOUCH THE FAN BLADE.

Reinstallation

1. Reinstall the inverter unit to the inverter angle with the three (3) screws.
2. Reconnect high voltage wire assembly and the inverter wire assembly to the inverter unit. Refer to "PICTORIAL DIAGRAM".

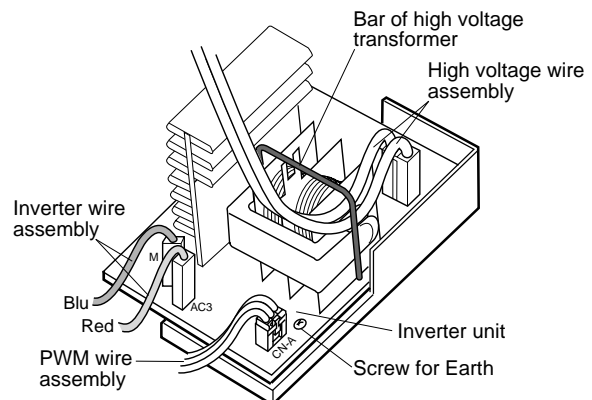

NOTE: The high voltage wire assembly should be routed under the bar of the high voltage transformer.

[HOW TO REMOVE TRANSISTOR Q1]

1. After the inverter unit is removed, take off the solder on legs of transistor Q1, bridge diode D1 and PTC thermistor PH1.
2. Remove the two (2) screws holding the heat sink to the

inverter unit board.

3. Remove the one (1) screw holding transistor Q1 to the heat sink.
4. Now, transistor Q1 is free

NOTE: Apply silicone grease (Toshiba YG6260 or Shinetsu G-746) to the back side of transistor Q1, before transistor Q1 is installed to the heat sink.

HOOD FAN MOTOR, HOOD DUCT AND OVEN LAMP SOCKET REMOVAL

1. Disconnect the power supply cord and remove the oven from wall and remove outer case. (Refer to procedure of "Removal of Oven from Wall" and "Outer case Removal")
2. Open the door and block it open.
3. To discharge high voltage capacitor, wait for 60 seconds.
4. Disconnect the 6-pin connector of the hood fan motor from the main wire harness located at the right edge of the hood duct and release the snap band from the hood duct.
5. Remove the hood fan motor from the hood duct by lifting it up.
6. Now, the hood fan motor is free.
7. Remove one (1) screw holding the hood duct to the oven cavity front plate.
8. Release the 6-pin connector and the 3-pin connector of the main harness A from the hood duct.
9. Disconnect the wire leads from the fan motor and chassis support, and release the wire leads from holes of the hood duct.
10. Remove the two (2) unit mounting screws from the

- chassis support (right side) and the hood duct (left side).
11. Remove the one (1) screw holding the chassis support.
12. Remove the chassis support.
13. Remove the hood duct from the oven cavity by lifting it up
14. Screw the oven lamp off from the lamp socket.
15. Remove the lamp socket from the lamp angle.
16. Pull the wire leads from the oven lamp socket by pushing the terminal hole of the oven lamp socket with the small flat type screw driver.
17. Now, the oven lamp socket and the hood duct are free.

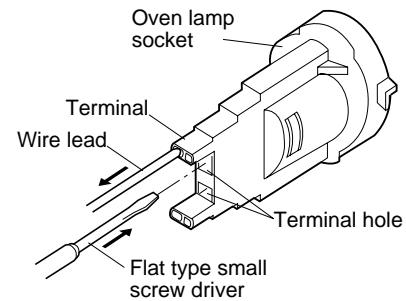

MAGNETRON REMOVAL

1. Disconnect the power supply cord, remove the oven from wall and remove outer case (Refer to procedure of "Removal of Oven from Wall" and "Outer case Removal".)
2. Open the door and block it open.
3. To discharge high voltage capacitor, wait for 60 seconds.
4. Disconnect the wire leads from the fan motor and the chassis support, and release them from the holes of hood duct.
5. Remove the one (1) screw holding the hood duct to the oven cavity front plate, and lift up the fan motor side of the hood duct.
6. Disconnect the high voltage wire assembly from the magnetron.

7. Remove the inverter unit from the right base plate, referring to "INVERTER UNIT REMOVAL".
8. Carefully remove four (4) mounting screws holding the magnetron to waveguide. When removing the screws hold the magnetron to prevent it from falling.
9. Remove the magnetron from the unit with care so the magnetron tube should not be hit by any metal object around the tube.
10. Remove the one (1) screw holding the magnetron air guide to the magnetron.
11. Remove the magnetron air guide

CAUTION: WHEN REPLACING THE MAGNETRON, BE SURE THE R.F. GASKET IS IN PLACE AND MOUNTING SCREWS ARE TIGHTENED SECURELY.

THERMAL CUT-OUT (OVEN) REMOVAL

1. Disconnect the power supply cord and remove the oven from wall and remove outer case. (Refer to procedure of "Removal of Oven from Wall" and "Outer case Removal")
2. Open the door and block it open.
3. To discharge high voltage capacitor, wait for 60 seconds.
4. Remove two (2) unit mounting screws.
5. Remove the hood duct. (Refer to the procedure of "

HOOD FAN MOTOR, HOOD DUCT AND OVEN LAMP SOCKET REMOVAL".

6. Straighten the tab holding the thermal cut-out to the top plate of the oven cavity.
7. Release the thermal cut-out (oven) from the one slit of the oven cavity top plate.

8. Disconnect the wire leads from the thermal cut-out (oven).
9. Now, the thermal cut-out (oven) is free.

NOTE: When the tab is broken or turned off, use the another tab which is fixed near the slit when the new thermal cut-out is replaced.

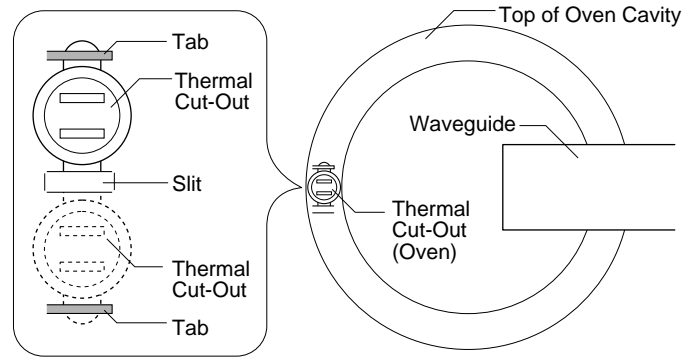

HOOD FAN THERMAL CUT-OUT REMOVAL

1. Disconnect the power supply cord and remove the oven from wall and remove outer case. (Refer to procedure of "Removal of Oven from Wall" and "Outer case Removal")
2. Open the door and block it open.
3. To discharge high voltage capacitor, wait for 60 seconds.
4. Disconnect the wire leads from the hood fan thermal

cut-out.

5. Remove one (1) screw holding the thermal cut-out to the right base plate.
6. Remove the hood fan thermal cut-out from the right base plate.
7. Now, the hood fan thermal cut-out is free.

TEMPERATURE FUSE (MAGNETRON) REMOVAL

1. Disconnect the power supply cord and remove the oven from wall and remove outer case. (Refer to procedure of "Removal of Oven from Wall" and "Outer case Removal")
2. Open the door and block it open.
3. To discharge high voltage capacitor, wait for 60 seconds.
4. Remove the hood fan motor and the hood duct from the oven cavity, referring to the procedure of " HOOD FAN

MOTOR, HOOD DUCT AND OVEN LAMP SOCKET REMOVAL".

5. Disconnect the wire leads from the temperature fuse (Magnetron).
6. Remove the one (1) screw holding the temperature fuse (Magnetron) to the oven cavity.
7. Now, the temperature fuse (Magnetron) is free.

COOLING FAN MOTOR REMOVAL

1. Disconnect the power supply cord, remove the oven from wall and remove outer case (Refer to procedure of "Removal of Oven from Wall" and "Outer case Removal".)
2. Open the door and block it open.
3. To discharge high voltage capacitor, wait for 60 seconds.
4. Disconnect the wire leads from the fan motor and the chassis support.
5. Remove one (1) screw holding the hood duct to oven cavity.
6. Release the wire leads from the hole of the hood duct.
7. Lift up the fan motor side of the hood duct.
8. Remove the two (2) screws holding the fan motor to the hood duct.
9. Remove the fan blade from the fan motor shaft according the following procedure.
10. Hold the edge of the rotor of the fan motor by using a pair of groove joint pliers.

CAUTION:

- * **Make sure that no metal pieces enter the gap between the rotor and the stator of the fan motor because the rotor is easily pinched by pliers and metal pieces may be produced.**
- * **Do not touch the pliers to the coil of the fan motor because the coil may be cut or injured.**
- * **Do not disfigure the bracket by touching with the pliers.**

11. Remove the fan blade from the shaft of the fan motor by pulling and rotating the fan blade with your hand.
12. Now, the fan blade will be free.

CAUTION:

- * **Do not reuse the removed fan blade because the hole (for shaft) may be larger than normal.**
13. Now, the fan motor is free.

INSTALLATION

1. Install the fan blade to the fan motor shaft according to the following procedure.
2. Hold the center of the bracket which supports the shaft of the fan motor on the flat table.
3. Apply the screw lock tight into the hole (for shaft) of the fan blade.
4. Install the fan blade to the shaft of fan motor by pushing the fan blade with a small, light weight, ball peen hammer or rubber mallet.
5. Install the fan motor to the hood duct with the two (2) screws.

CAUTION:

- * **Do not hit the fan blade hard when installing because the bracket may be disfigured.**
 - * **Make sure that the fan blade rotates smooth after installation.**
 - * **Make sure that the axis of the shaft is not slanted.**
6. Install the hood duct to the oven cavity with the one (1) screw.

7. Re-install the wire leads to the hole of the hood duct.
8. Connect the wire leads to the fan motor and chassis support, referring to the pictorial diagram.

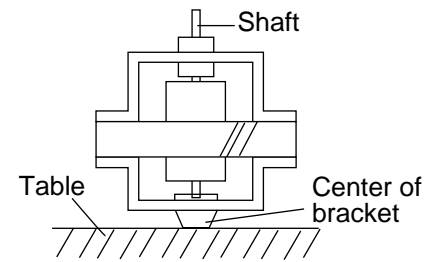
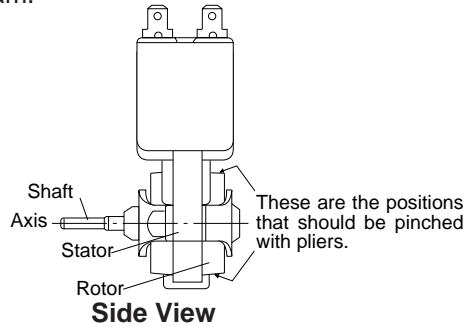
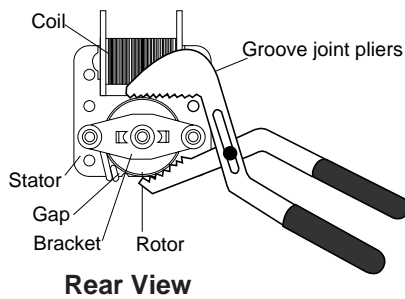

9. Refer to procedure of "OUTER CASE REMOVAL". And reverse their procedure. And re-install the outer case.

TURNTABLE MOTOR REMOVAL

1. Disconnect the power supply cord.
2. Open the door and block it open.
3. Remove the three (3) screws holding the base cover to the oven cavity.
4. Open the base cover from the oven cavity by pulling down.
5. Disconnect the wire leads from the turntable motor.
6. Remove one (1) screw holding turntable motor to the oven cavity.
7. Now the turntable motor is free.

STIRRER MOTOR REMOVAL

1. Disconnect the power supply cord and remove the oven from wall and remove outer case. (Refer to procedure of "Removal of Oven from Wall" and Outer case Removal")
2. Open the door and block it open.
3. To discharge high voltage capacitor, wait for 60 seconds.
4. Remove the hood fan motor and the hood duct from the oven cavity, referring to the procedure of "HOOD FAN MOTOR, HOOD DUCT AND OVEN LAMP SOCKET REMOVAL".
5. Disconnect the wire leads from the stirrer motor.
6. Remove the two (2) screws holding the stirrer motor to the waveguide of the oven cavity.
7. Remove the stirrer motor from the waveguide.
8. Now, the stirrer motor is free.
9. When installing the stirrer motor, the shaft of stirrer motor must be inserted to the stirrer fan shaft. Refer to the procedure of "STIRRER COVER AND STIRRER FAN INSTALLATION".

STIRRER COVER AND STIRRER FAN INSTALLATION

1. Put the stirrer fan on the stirrer cover to match the stirrer fan shaft to the center of the stirrer support.
2. Insert the shaft of stirrer fan to the shaft of stirrer motor.
3. Insert the cutout of stirrer cover to the tabs on the ceiling.
4. Install the stirrer cover to the oven cavity, and secure it by one canoe clip.

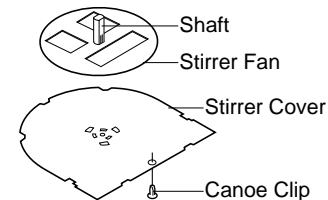

OVEN LAMP REMOVAL

1. Disconnect the power supply cord.
2. Remove one (1) screw holding the hood exhaust louver to oven cavity front flange.
3. Remove the hood exhaust louver from the oven by pushing the right and left tabs of the hood exhaust louver. (Refer to procedure of "HOOD EXHAUST LOUVER REMOVAL")
4. Lift the oven lamp cover up.
5. Now, the oven lamp and the socket are found.
6. Screw the oven lamp off from the lamp socket.
7. Now, the oven lamp is free.

CONTROL PANEL ASSEMBLY, CONTROL UNIT AND KEY UNIT REMOVAL

1. Disconnect the power supply cord.
2. Open the door and block it open.
3. Remove one (1) screw holding the hood exhaust louver to oven cavity front flange.
4. Remove the hood exhaust louver from the oven by pushing the right and left tabs of the hood exhaust louver.
5. (Refer to procedure of "HOOD EXHAUST LOUVER REMOVAL")
5. Remove one (1) screw holding the control panel to the oven cavity front face plate.
6. Release the control panel from the oven cavity front face plate by lifting it up.

7. Disconnect the wire leads from the relay RY1.
8. Disconnect the connectors CN-A, CN-B, CN-F, CN-E and CN-H from the control unit.
9. Remove the control panel assembly from the oven.
10. Now, the control panel assembly is free.
11. Disconnect the connector CN-G from the control unit.
12. Release the four (4) screws holding the LSI unit to the key fixing plate.
13. Remove two (2) screws holding the power unit to the key fixing plate.
14. Release the two (2) tabs holding the power unit to the key fixing plate.
15. Now, the control unit is free.
16. Remove the one (1) screw holding the key fixing plate to the control panel.

17. Release the nine (9) tabs holding the key fixing plate to the control panel.
18. Remove the key fixing plate from the control panel.
19. Tear the key unit from the key fixing plate.
20. Now, the key unit is free

NOTES FOR KEY UNIT REPLACEMENT

1. Do not reuse the torn key unit because the performance of the adhesive becomes weak.
2. Before attaching a new key unit, wipe off remaining adhesive on the key fixing plate surfaces completely with a soft cloth soaked in alcohol.
3. When attaching the key unit to the key fixing plate, adjust the upper edge and right edge of the key unit to the correct position of key fixing plate.
4. Stick the key unit firmly to the key fixing plate by rubbing with soft cloth not to scratch.

POSITIVE LOCK® CONNECTOR (NO-CASE TYPE) REMOVAL

1. Disconnect the power supply cord and remove the oven from wall and remove outer case. (Refer to procedure of "Removal of Oven from Wall" and "Outer case Removal")
2. Open the door and block it open.
3. To discharge high voltage capacitor, wait for 60 seconds.
4. Push the lever of positive lock® connector.
5. Pull down on the positive lock® connector.

CAUTION: WHEN CONNECTING THE POSITIVE LOCK® CONNECTORS TO THE TERMINALS, INSTALL THE POSITIVE LOCK® SO THAT THE LEVER FACES YOU.

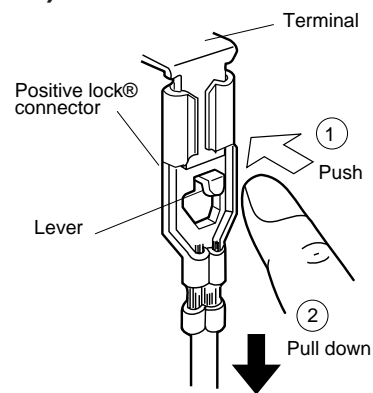

Positive lock® connector

STOP SWITCH, PRIMARY INTERLOCK SWITCH, SECONDARY INTERLOCK SWITCH AND MONITOR SWITCH REMOVAL

1. Disconnect the power supply cord and remove the oven from wall and remove outer case. (Refer to procedure of "Removal of Oven from Wall" and "Outer case Removal")
2. Open the door and block it open.
3. To discharge high voltage capacitor, wait for 60 seconds.
4. Remove the control panel assembly, referring to the procedure of "CONTROL PANEL ASSEMBLY , CONTROL UNIT AND KEY UNIT REMOVAL".
5. Remove the two (2) screws holding the latch hook to the oven cavity front flange.
6. Remove the latch hook from the oven cavity front flange.
7. Disconnect the wire leads of each switch.
8. Remove each switch from the latch hook by pushing the one (1) stopper tub holding each switch.

9. Now, each switch is free.

Re-install

1. Re-install each switch in its place. The secondary interlock switch is in the lower position, stop switch and primary interlock switch are in the upper position and the monitor switch is in the middle position.
2. Re-connect wire leads to each switch. Refer to pictorial diagram.
3. Secure the latch hook (with two (2) mounting screws) to oven cavity front flange.
4. Make sure that the monitor switch is operating properly and check continuity of the monitor circuit. Refer to chapter "Test Procedure" and "Adjustment procedure".

STOP SWITCH, PRIMARY INTERLOCK SWITCH, SECONDARY INTERLOCK SWITCH AND MONITOR ADJUSTMENT

1. Disconnect the power supply cord and remove the oven from wall and remove outer case. (Refer to procedure of "Removal of Oven from Wall" and "Outer case Removal")
2. Open the door and block it open.
3. To discharge high voltage capacitor, wait for 60 seconds.

4. Remove the control panel assembly, referring to the procedure of "CONTROL PANEL ASSEMBLY , CONTROL UNIT AND KEY UNIT REMOVAL".
- If the stop switch, secondary interlock switch and monitor switch do not operate properly due to a misadjustment, the

following adjustment should be made.

5. Loosen the two (2) screws holding latch hook to the oven cavity front flange.
6. With door closed, adjust latch hook by moving it back and forth, and up and down. In and out play of the door allowed by the upper and lower position of the latch hook should be less than 0.5mm. The vertical position of the latch hook should be adjusted so that the primary interlock switch and secondary interlock switch are activated with the door closed. The horizontal position of the latch hook should be adjusted so that the monitor switch and stop switch are activated with the door closed.
7. Secure the screws with washers firmly.
8. Check all of the switches operation. If any switch has not activated with the door closed, loosen screw and adjust the latch hook position.

After adjustment, check the following.

1. In and out play of door remains less than 0.5mm when in the latched position. First check upper position of latch hook, pushing and pulling upper portion of door toward the oven face. Then check lower portion of the latch hook, pushing and pulling lower portion of the door toward the oven face. Both results (play in the door) should be less than 0.5mm.

2. The contact of primary interlock switch and secondary interlock switch open within 1.2mm gap between right side of cavity face plate and door when door is open.
3. Monitor switch contacts close when door is opened.
4. The stop switch contacts open when door is open.
5. Re-install outer case and check for microwave leakage around door with an approved microwave survey meter. (Refer to Microwave Measurement Procedure.)

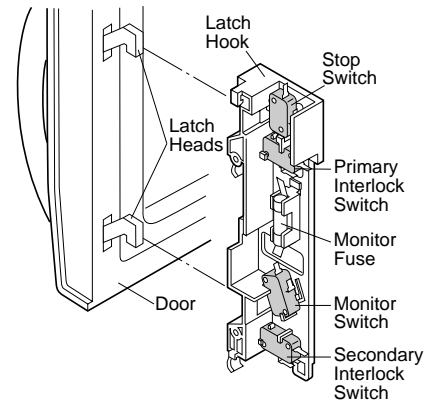

Figure C-1. Latch Switch Adjustments

DOOR REPLACEMENT

DOOR ASSEMBLY REMOVAL

1. Disconnect the power supply cord and remove the oven from wall and remove outer case. (Refer to procedure of "Removal of Oven from Wall" and "Outer case Removal")
2. Open the door and block it open.
3. To discharge high voltage capacitor, wait for 60 seconds.
4. Remove the hood exhaust louver from the oven cavity by pushing the right and left tabs of the hood exhaust louver. (Refer to the procedure of "HOOD EXHAUST LOUVER REMOVAL".)
5. Insert a putty knife (thickness of about 0.5mm) into the gap (A) between the door stopper and the choke cover as shown in Figure C-3 to free engaging parts.
6. Lift up the door stopper.
7. Now, the door stopper is free from the door assembly.
8. Lift up the door assembly to release the upper and lower door hinge pins from the upper and lower oven hinges.
9. Now, the door assembly is free.

Note: When the individual parts are replaced, refer to "Door Disassembly".

DOOR ASSEMBLY RE-INSTALL

1. On re-installing door, insert the lower oven hinge to lower door hinge pin.
2. Insert the upper oven hinge to the upper door hinge pin.
3. Shut the door (close the contacts of interlock switches).
4. Make sure upper and lower oven hinges are inserted into the upper and lower door hinge pins.
5. Make sure the door is parallel with oven face lines (left and upper side lines) and door latch heads pass through latch holes correctly.
6. Re-install the door stopper to the door assembly.

7. Re-install the hood exhaust louver to the oven cavity front face plate.

Note: After any service to the door;

- (A) **Make sure that stop switch, primary interlock switch and secondary interlock switch are operating properly. (Refer to chapter "Test Procedures".)**
- (B) **An approved microwave survey meter should be used to assure compliance with proper microwave radiation emission limitation standards.**

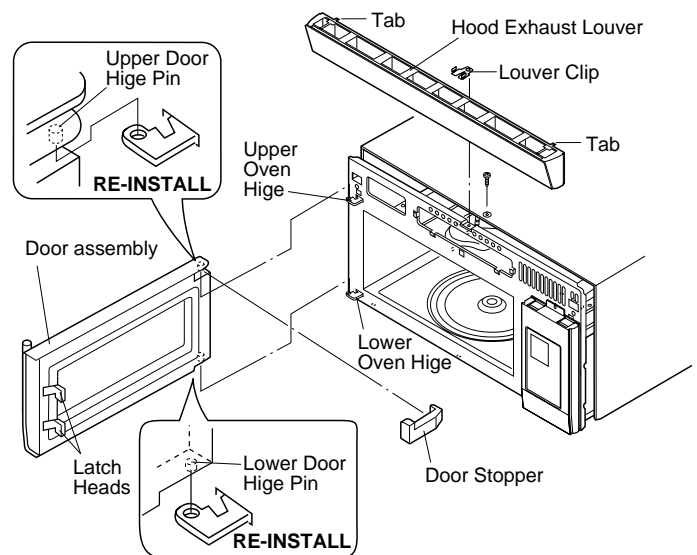

Figure C-2. Door Replacement and adjustment

After any servicing, make sure of the following :

1. Door latch heads smoothly catch latch hook through

latch holes and that latch head goes through center of latch hole.

2. Deviation of door alignment from horizontal line of cavity face plate is to be less than 1.0mm.
3. Door is positioned with its face pressed toward cavity face plate.
4. Re-install outer case and check for microwave leakage around door with an approved microwave survey meter. (Refer to Microwave Measurement Procedure.)

DOOR DISASSEMBLY

1. Disconnect the power supply cord and remove the oven from wall and remove outer case. (Refer to procedure of "Removal of Oven from Wall" and "Outer case Removal")
2. Open the door and block it open.
3. To discharge high voltage capacitor, wait for 60 seconds.
4. Remove the hood exhaust louver from the oven cavity by pushing the right and left tabs of the hood exhaust louver. (Refer to the procedure of "HOOD EXHAUST LOUVER REMOVAL".)
5. Remove door assembly, refer to "Door Replacement". Replacement of door components are as follows:
6. Place door assembly on a soft cloth with latches facing up.

Note: As the engaging part of choke cover and door frame are provided at 15 places, do not force any particular part.

CHOKE COVER

7. Insert a putty knife (thickness of about 0.5mm) into the gap (A) between the choke cover and door stopper and between the choke cover and the door frame as shown Figure C-3 to free engaging parts.
8. Pry the choke cover by inserting a putty knife in order shown in Figure C-3.
9. Now choke cover is free from door panel and door frame.

DOOR FRAME

10. Remove six (6) screws holding the door panel and the door handle to the door frame assembly.
 11. Release the door frame assembly from the door panel.
- NOTE: It is easier to release the engaging parts of the upper or lower door hinge pin side at first.
12. Now, door frame assembly is free.

Note: The door on a microwave oven is designed to act as an electronic seal preventing the leakage of microwave energy from oven cavity during cook cycle. This function does not require that door be air-tight, moisture (condensation)-tight or light-tight. Therefore, occasional appearance of moisture, light or sensing of gentle warm air movement around oven door is not abnormal and do not of themselves indicate a leakage of microwave energy from oven cavity.

LATCH SPRING, LATCH HEAD AND DOOR PANEL

13. Release the latch spring from the tab of the latch head and tab of the door frame.
14. Release the latch head from the door frame.
15. Now, the latch spring, latch head and door frame are free.

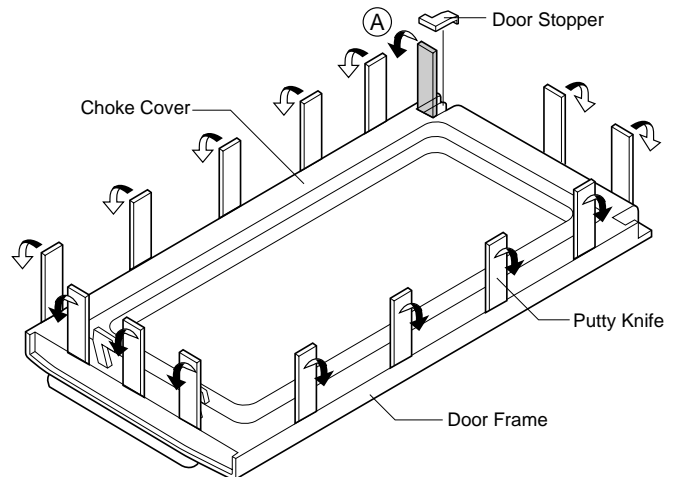

Figure C-3. Door Disassembly

DOOR GLASS

16. Remove the glass stopper from the door frame by releasing the tab of door frame.
17. At first, slide the door glass rightwards (toward the glass stopper side), and then slide it up. And release it from the left and lower long tabs of the door frame.
18. Release the door glass from the upper long tab of the door frame.
19. Now, the door glass is free.

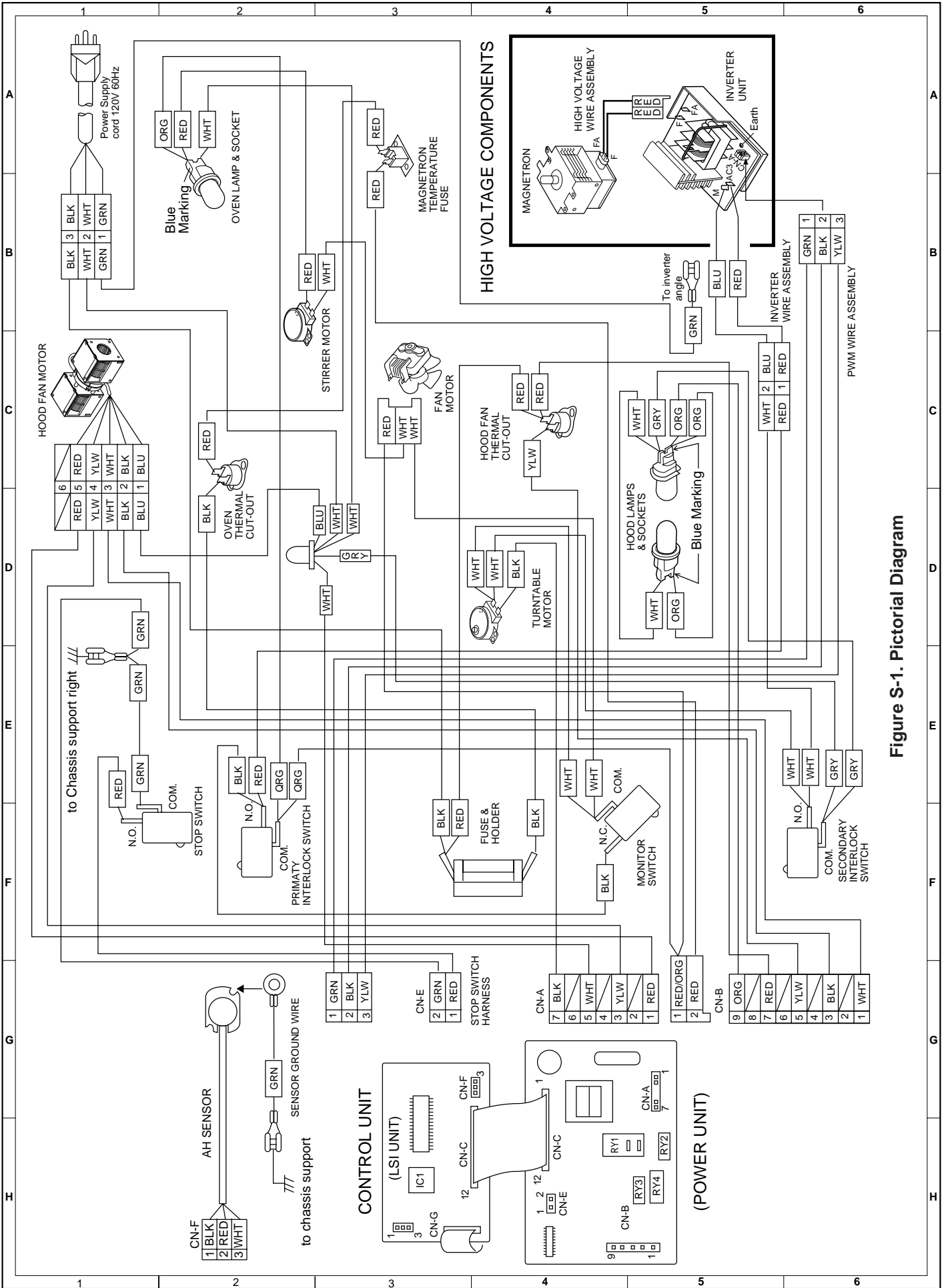
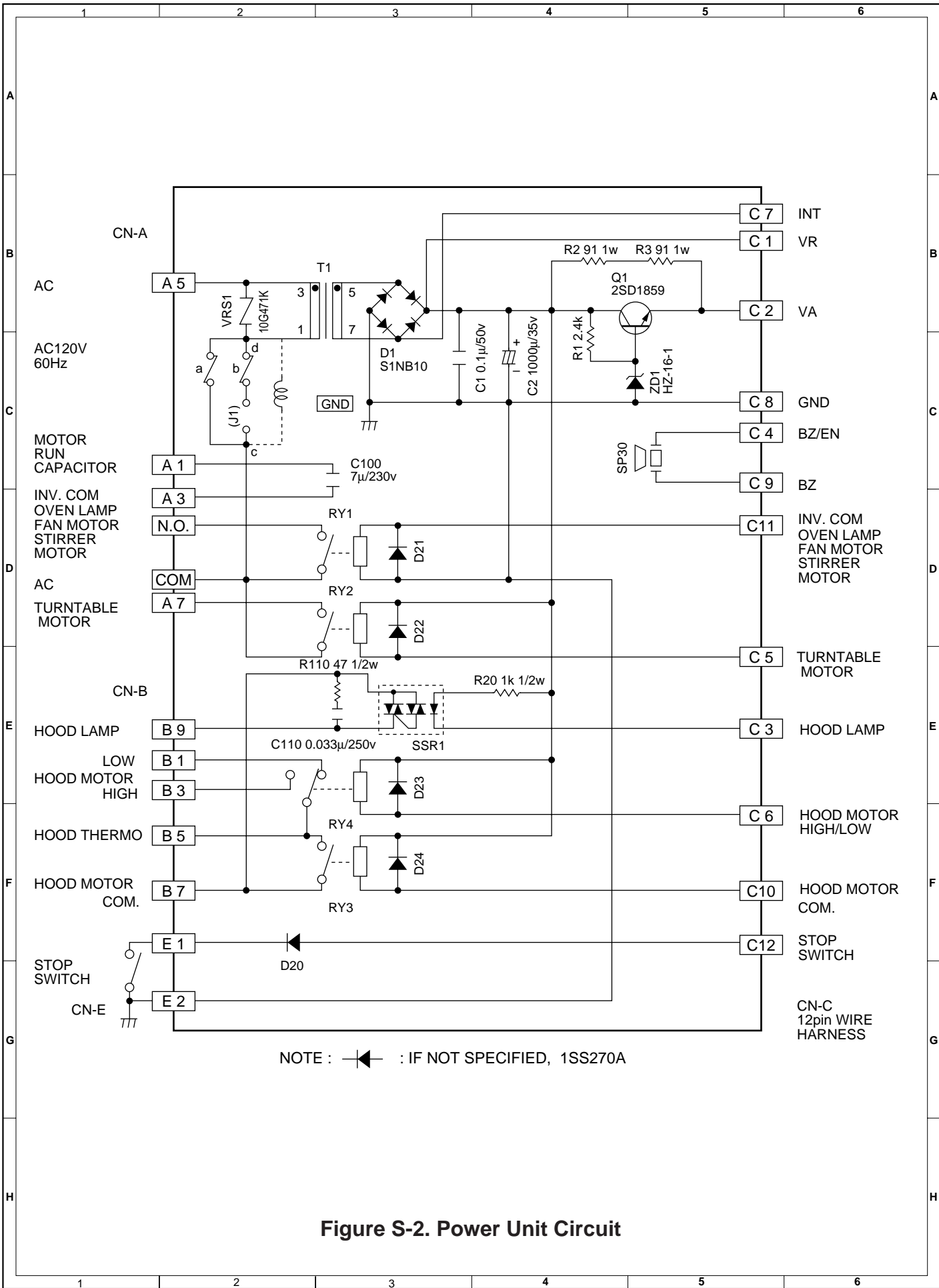

Figure S-1. Pictorial Diagram



NOTE : : IF NOT SPECIFIED, 1SS270A

Figure S-2. Power Unit Circuit

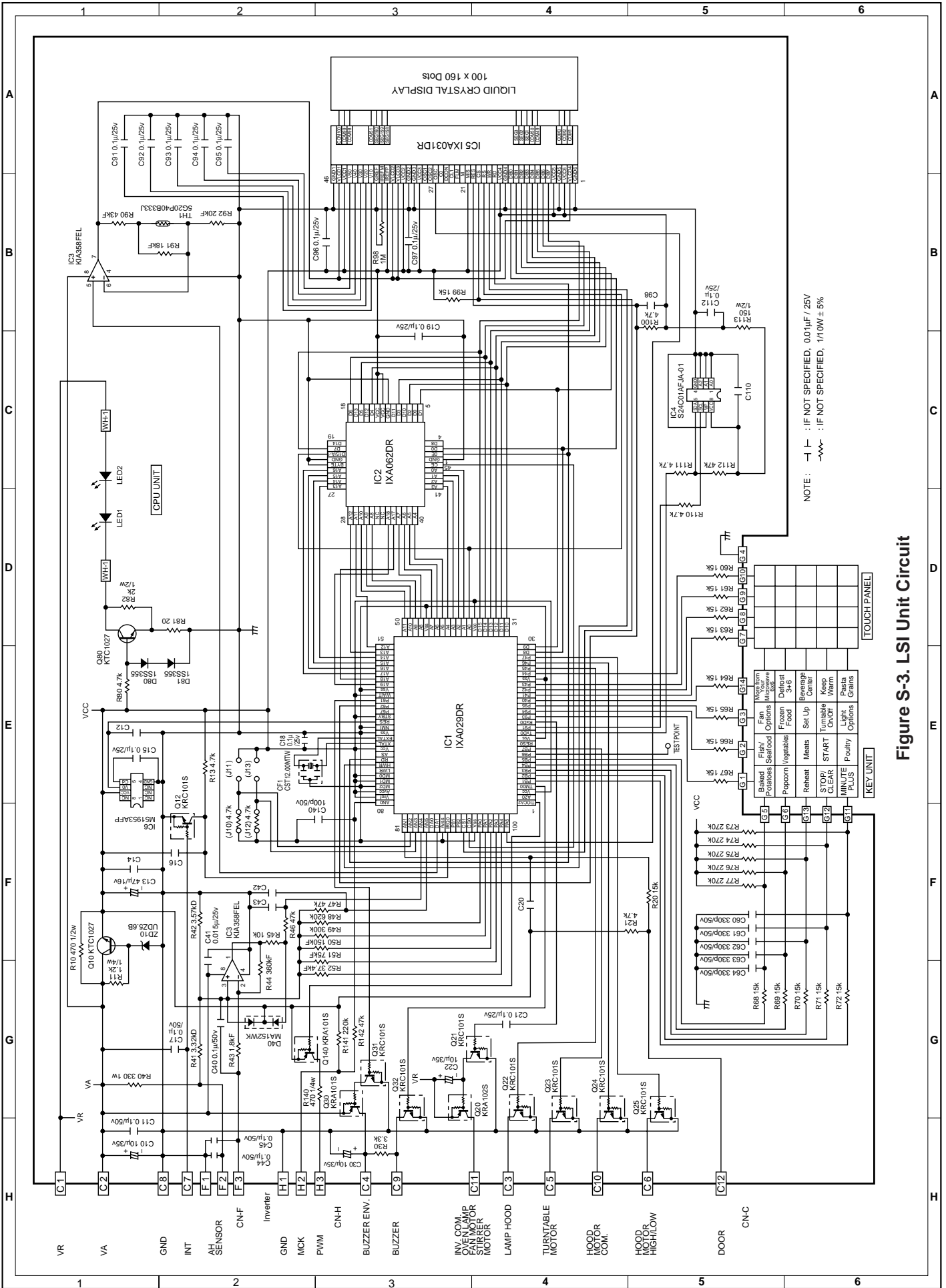

Figure S-3. LSI Unit Circuit

PARTS LIST

**Note: The parts marked "Δ" may cause undue microwave exposure.
The parts marked "*" are used in voltage more than 250V.**

"§" MARK: PARTS DELIVERY SECTION

REF. NO.	PART NO.	§	DESCRIPTION	Q'TY	CODE
----------	----------	---	-------------	------	------

ELECTRIC PARTS

1- 1	RMOTEA346WRE0	M	Fan motor	1	AR	
1- 2	RLMPTA068WRE0	M	Oven lamp	3	AE	
1- 3	QFS-TA013WRE0	M	Temperature fuse 150°C (Magnetron)	1	AG	
1- 4	RMOTDA211WRE0	M	Turntable motor	1	AL	
1- 5	RMOTDA214WRE0	M	Stirrer motor	1	AQ	
1- 6	RTHM-0044MRE0	M	Thermal cut-out N.O. 60°C (Hood Fan)	1	AH	
1- 7	RTHM-A070WRE0	M	Thermal cut-out 145°C (Oven)	1	AG	
Δ*	1- 8	RV-MZA309WRZZ	M	Magnetron	1	BD
	1- 9	QFSHDB003MRE0	M	Fuse holder	1	AD
	1-10	QSW-MA085WRE0	M	Secondary interlock/primary interlock/stop switches	3	AE
	1-11	FFS-BA016/KIT	M	Monitor switch (V-16G-2C25) with fuse 20A assembly	1	AF
	1-12	FACCDB011MRE0	M	Power supply cord	1	AP
	1-13	QSOCLB006MRE0	M	Oven lamp socket	3	AE
	1-14	FMOTEA402WRK0	M	Hood fan motor	1	BE
	1-15	FDTCTA201WRK0	M	AH Sensor	1	AR
*	1-16	DPWBFC071WRUZ	M	Inverter unit	1	BQ
*	D1	RBR--A001VBE0	J	Bridge diode	1	AM
*	D11	RH-DZA059DRE0	J	High voltage diode (UX-F0B)	1	AH
*	D12	RH-DZA079DRE0	J	High voltage diode (UX-F0BL)	1	AL
*	Q1	RH-TZA137DRE0	J	Power transistor (CT60AM-18F)	1	AT
	Q2	VS2SC1740S/-3	J	Transistor (2SC1740S)	1	AB
	Q3	VS2SA673///-3	J	Transistor (2SA673)	1	AB
	VRS2	RH-VZA041DRE0	J	Varistor (ENC271D-14A)	1	AF
	VRS3	RH-VZA010DRE0	J	Varistor (TNR15G471K356)	1	AE
	VRS3	RH-VZA042DRE0	J	Varistor (ENC471-14A-TJ-B) (INterchangeable)	1	AF

CABINET PARTS

2- 1	LSTY-B021MRP0	M	Rear stay	1	AF
2- 2	FDIF-B004MRK0	M	Hood exhaust louver [R-1750]	1	AW
2- 2	FDIF-B005MRK0	M	Hood exhaust louver [R-1751]	1	AW
2- 2	FDIF-B006MRK0	M	Hood exhaust louver [R-1752]	1	AW
2- 2	FDIF-B001MRK0	M	Hood exhaust louver [R-1754]	1	BD
2-2-1	LANGTB051MRP0	M	Louver clip	1	AG
2- 3	GDAI-B059MRP0	M	Right base plate	1	BC
2- 4	PCUSUB040MRP0	M	Base cover cushion	1	AA
2- 5	GCABUB084MRP0	M	Outer case cabinet [R-1750]	1	BA
2- 5	GCABUB090MRP0	M	Outer case cabinet [R-1751]	1	BC
2- 5	GCABUB100MRP0	M	Outer case cabinet [R-1752]	1	BB
2- 5	GCABUB084MRP0	M	Outer case cabinet [R-1754]	1	BA
2- 6	TMAPCB064MRR0	M	Schematic diagram	1	AB
2- 7	FANGKB009MRY0	M	Hood lamp glass assembly [R-1750]	1	AN
2- 7	FANGKB010MRY0	M	Hood lamp glass assembly [R-1751]	1	AM
2- 7	FANGKB013MRY0	M	Hood lamp glass assembly [R-1752]	1	AK
2- 7	FANGKB009MRY0	M	Hood lamp glass assembly [R-1754]	1	AN
2-7-1	LANGQB016MRP0	M	Hood lamp glass angle [R-1750]	1	AG
2-7-1	LANGQB020MRP0	M	Hood lamp glass angle [R-1751]	1	AG
2-7-1	LANGQB049MRP0	M	Hood lamp glass angle [R-1752]	1	AG
2-7-1	LANGQB016MRP0	M	Hood lamp glass angle [R-1754]	1	AG
2-7-2	PGLSPB004MRE0	M	Hood lamp glass	1	AH
2- 8	PCOVBP091MRT0	M	Base cover [R-1750]	1	AY
2- 8	PCOVBP092MRT0	M	Base cover [R-1751]	1	AY
2- 8	PCOVBP090MRT0	M	Base cover [R-1752]	1	AY
2- 8	PCOVBP091MRT0	M	Base cover [R-1754]	1	AY

CONTROL PANEL PARTS

3- 1	DPWFB097MRU0	M	Power supply unit	1	BA
3- 1A	QCNCMA447DRE0	M	4-pin connector CN-A	1	AF
3- 1B	QCNCMA448DRE0	M	5-pin connector CN-B	1	AB
3- 1C	QCNCMA275DRE0	J	2-pin connector CN-E	1	AB
3- 1D	FW-VZB181MRE0	M	12pin lead wire harness CN-C	1	AV
C1	RC-KZA087DRE0	J	Capacitor 0.1 uF 50V	1	AA
C2	VCEAB31VW108M	J	Capacitor 1000 uF 35V	1	AF
C100	RC-QZB014MRE0	M	Capacitor 7 uF 230V	1	AK
C110	RC-QZB019MRE0	M	Capacitor 0.033 uF 250V	1	AC
D1	RSRCDA013DRE0	J	Diode bridge (S1NB10)	1	AG
D20-24	VHD1SS270A/-1	J	Diode (1SS270A)	5	AA

REF. NO.	PART NO.	§	DESCRIPTION	Q'TY	CODE
Q1	VS2SD1859// -3	J	Transistor (2SD1859R)	1	AC
R1	VRD-B12EF242J	J	Resistor 2.4k ohm 1/4W	1	AA
R2-3	VRS-B13AA910J	J	Resistor 91 ohm 1W	2	AC
R20	VRD-B12HF102J	J	Resistor 1k ohm 1/2W	1	AA
R110	VRS-A12HA470J	J	Resistor 47 ohm 1/2W	1	AH
RY1	RRLY-A113DRE0	M	Relay (DU24D1-1PR(M))	1	AG
RY2-3	RRLY-B004MRE0	M	Relay (FTR-F3AA024E)	2	AG
RY4	RRLY-A112DRE0	M	Relay (VE24HSE-K)	1	AH
SSR1	RTR--A001DRE0	M	Solid state relay	1	AG
SP1	RALM-A014DRE0	J	Buzzer (PKM22EPT)	1	AG
T1	RTRNBP020MRE0	M	Transformer	1	BE
VRS1	RH-VZA032DRE0	J	Varistor (10G471K)	1	AE
ZD1	VHEHZ161// -1	J	Zener diode (HZ16-1)	1	AA
3- 2	DUNT-B036MRK0	M	LSI unit	1	BQ
3- 3	FPNLCB319MRK0	M	Control panel sub. assembly [R-1750]	1	BD
3- 3	FPNLCB322MRK0	M	Control panel sub. assembly [R-1754]	1	BG
3- 3	FPNLCB326MRK0	M	Control panel sub, assembly [R-1751]	1	BD
3- 3	FPNLCB327MRK0	M	Control panel sub, assembly [R-1752]	1	BD
3- 3-1	FUNTKB264MRE0	M	Key unit [R-1750]	1	AR
3- 3-1	FUNTKB264MRE0	M	Key unit [R-1754]	1	AR
3- 3-1	FUNTKB270MRE0	M	Key unit [R-1751]	1	AR
3- 3-1	FUNTKB271MRE0	M	Key unit [R-1752]	1	AR
3- 3-2	HPNLCB129MRR0	M	Control panel [R-1750]	1	AQ
3- 3-2	HPNLCB132MRR0	M	Control panel [R-1751]	1	AQ
3- 3-2	HPNLCB133MRR0	M	Control panel [R-1752]	1	AQ
3- 3-2	*****	M	Control panel (Not replaceable part) [R-1754]	1	--
3- 3-3	XEPSD30P10XS0	M	Screw; 3mm x 10mm	1	AB
3- 3	XEPSD30P10XS0	M	Screw; 3mm x 10mm	6	AB

OVEN PARTS

4- 1	FFTA-B005MRK0	M	Exhaust damper assembly	1	AH
4- 2	FROLPB025MRK0	M	Turntable support assembly	1	AN
4- 3	NTNT-A090WRE0	M	Turntable tray	1	AN
4- 4	LANGQB048MRP0	M	Inverter angle	1	AF
4- 5	FCOVBP016MRK0	M	Stirrer cover assembly	1	AN
4- 6	FFAN-B012MRK0	M	Stirrer fan assembly	1	AG
4- 7	*****	M	Oven cavity (Not replaceable part)	1	--
4- 8	PPACGB014MRF0	M	Turntable motor packing	1	AA
4- 9	PHOK-B017MRF0	M	Latch hook	1	AG
4-10	LANGTB050MRP0	M	Unit mounting plate	1	AP
4-11	NFANPB001MRE0	M	Fan blade	1	AC
4-12	LBSHC0037WRE0	M	Cord bushing	1	AB
4-13	PCOVBP065MRP0	M	Oven lamp cover	1	AD
4-14	PDUC-B095MRP0	M	Hood intake duct R	1	AM
4-15	PCUSUB039MRP0	M	Hood intake duct cushion	2	AA
4-16	PFILWB005MRP0	M	Lamp filter	1	AB
4-17	LANGTB046MRP0	M	Chassis support left	1	AD
4-18	LANGTB040MRP0	M	Chassis support right	1	AE
4-19	PDUC-B094MRF0	M	Hood duct	1	AL
4-20	LHLD-B012MRF0	M	Rack holder	4	AF
4-21	LSTPPB031MRF0	M	Door stopper	1	AC
4-22	PDUC-B098MRP0	M	Magnetron air guide	1	AC
4-23	PCUSUB047MRP0	M	Air flow cushion	2	AD
4-24	PCUSUB045MRP0	M	Cabinet cushion	1	AD

DOOR PARTS

5	CDORFB253MRK0	M	Door assembly [R-1750]	1	BG
5	CDORFB257MRK0	M	Door assembly [R-1751]	1	BG
5	CDORFB258MRK0	M	Door assembly [R-1752]	1	BG
5	CDORFB256MRK0	M	Door assembly [R-1754]	1	BG
5- 1	FDORFB060MRT0	M	Door panel assembly	1	AX
5- 2	FCOV-B161MRK0	M	Door frame assembly [R-1750]	1	BD
5- 2	FCOV-B163MRK0	M	Door frame assembly [R-1751]	1	BD
5- 2	FCOV-B164MRK0	M	Door frame assembly [R-1752]	1	BD
5- 2	FCOV-B162MRK0	M	Door frame assembly [R-1754]	1	BD
5-2-1	PGLSPB020MRE0	M	Front door glass [R-1750]	1	AQ
5-2-1	PGLSPB021MRE0	M	Front door glass [R-1751]	1	AQ
5-2-1	PGLSPB022MRE0	M	Front door glass [R-1752]	1	AQ
5-2-1	PGLSPB020MRE0	M	Front door glass [R-1754]	1	AQ
5-2-2	LSTPPB030MRF0	M	Latch head	1	AC
5-2-3	LSTPPB035MRF0	M	Glass stopper	1	AC
5-2-4	MSPRTA046WRE0	M	Latch spring	1	AB
5-2-5	GWAKPB117MRF0	M	Door frame [R-1750]	1	AZ

REF. NO.	PART NO.	§	DESCRIPTION	Q'TY	CODE
Δ 5-2-5	GWAKPB118MRF0	M	Door frame [R-1751]	1	AZ
Δ 5-2-5	GWAKPB119MRF0	M	Door frame [R-1752]	1	AZ
5-2-5	*****	M	Door frame(Not replaceable part) [R-1754]	1	--
5- 3	FCOVHB005MRK0	M	Choke cover assembly	1	AH
Δ 5- 4	PSHEPB024MRE0	M	Sealer film	1	AF
5- 5	FHNDPB005MRK0	M	Door handle assembly [R-1750]	1	AP
5- 5	FHNDPB007MRK0	M	Door handle assembly [R-1751]	1	AP
5- 5	FHNDPB008MRK0	M	Door handle assembly [R-1752]	1	AP
5- 5	FHNDPB006MRK0	M	Door handle assembly [R-1754]	1	AP
5- 6	XCPD40P08000	M	Screw : 4mm x 8mm	4	AA
5- 7	XCPD40P12000	M	Screw : 4mm x 12mm	2	AA

MISCELLANEOUS

6- 1	CFZK-B131MRK0	M	Installation material assembly	1	AM
6-1-1	LBSHC0040MRE0	M	Grommet	1	AC
6-1-2	LX-BZ0195WRE0	M	Toggle screw	4	AC
6-1-3	LX-MZB001MRE0	M	Cord holder	1	AB
6-1-4	XBRSD50P60000	M	Screw : 5mm x 60mm	2	AC
6-1-5	XOTSD40P12000	M	Screw : 4mm x 12mm	1	AA
6-1-6	XTSSD50P35000	M	Screw : 5mm x 35mm	6	AA
6-1-7	XWHSD50-16300	M	Washer	2	AA
6- 2	TINSEB227MRR0	M	Installation instruction	1	AC
6- 3	TINSEB228MRR0	M	Operation manual	1	AC
6- 4	TINSKB047MRR0	M	Top template	1	AC
6- 5	TINSKB048MRR0	M	Wall template	1	AB
* 6- 6	FW-QZB011MRE0	M	High voltage wire assembly	1	AG
6- 7	FW-VZB178MRE0	M	Main harness	1	AH
6- 8	TCAUAB041MRR0	M	DHHS sevice caution label	2	AA
6- 9	TCAUAB037MRR0	M	Monitor caution label	1	AA
6-10	TCAUAB005MRR0	M	DHHS caution label	1	AB
6-11	FW-VZB149MRE0	M	Stop switch harness	1	AM
6-12	PFIL-B004MRE0	M	Charcoal filter	1	AH
6-13	PFIL-B002MRE0	M	Grease filter	2	AF
6-14	PCLICB003MRE0	M	Canoe clip	1	AA
6-15	UAMI-B009MRM0	M	Rack	1	AR
6-16	QW-VZB010MRE0	M	Sensor ground wire	1	AB
6-17	TCAUAB018MRR0	M	Cleaning label	1	AC
6-18	FW-VZB180MRE0	M	Inverter wire assembly	1	AD
6-19	FW-QZB179MRE0	M	PWM wire assembly	1	AD

SCREWS,NUTS AND WASHERS

7- 1	XCPD40P08000	M	Screw : 4mm x 8mm	2	AA
7- 2	XOTSF40P12000	M	Screw : 4mm x 12mm [R-1750]	4	AB
7- 2	XOTSE40P12000	M	Screw : 4mm x 12mm [R-1751]	4	AA
7- 2	XOTSD40P12000	M	Screw : 4mm x 12mm [R-1752]	4	AA
7- 2	XOTSF40P12000	M	Screw : 4mm x 12mm [R-1754]	4	AB
7- 3	XOTSD40P12000	M	Screw : 4mm x 12mm	13	AA
7- 4	XBTSD40P08000	M	Screw : 4mm x 8mm	2	AA
7- 5	LX-CZA038WRE0	M	Special screw	4	AA
7- 6	LX-CZ0052WRE0	M	Special screw	2	AA
7- 7	LX-BZ0081YBE0	M	Screw : 4mm x 8mm	5	AA
7- 8	XCPD30P08000	M	Screw : 4mm x 8mm	2	AA
7- 9	LX-BZB012MRE0	M	Unit mounting screw	2	AD
7-10	XCBSD30P08000	M	Screw : 3mm x 8mm	3	AA
7-11	XHTSD40P08RV0	M	Screw : 4mm x 8mm	1	AA
7-12	XEPSD40P12000	M	Screw : 4mm x 12mm	2	AA

HOW TO ORDER REPLACEMENT PARTS

To have your order filled promptly and correctly, please furnish the following information.

1. MODEL NUMBER 2. REF. NO. 3. PART NO. 4. DESCRIPTION

Order Parts from the authorized SHARP parts Distributor for your area.

Defective parts requiring return should be returned as indicated in the Service Policy.

OVEN AND CABINET PARTS

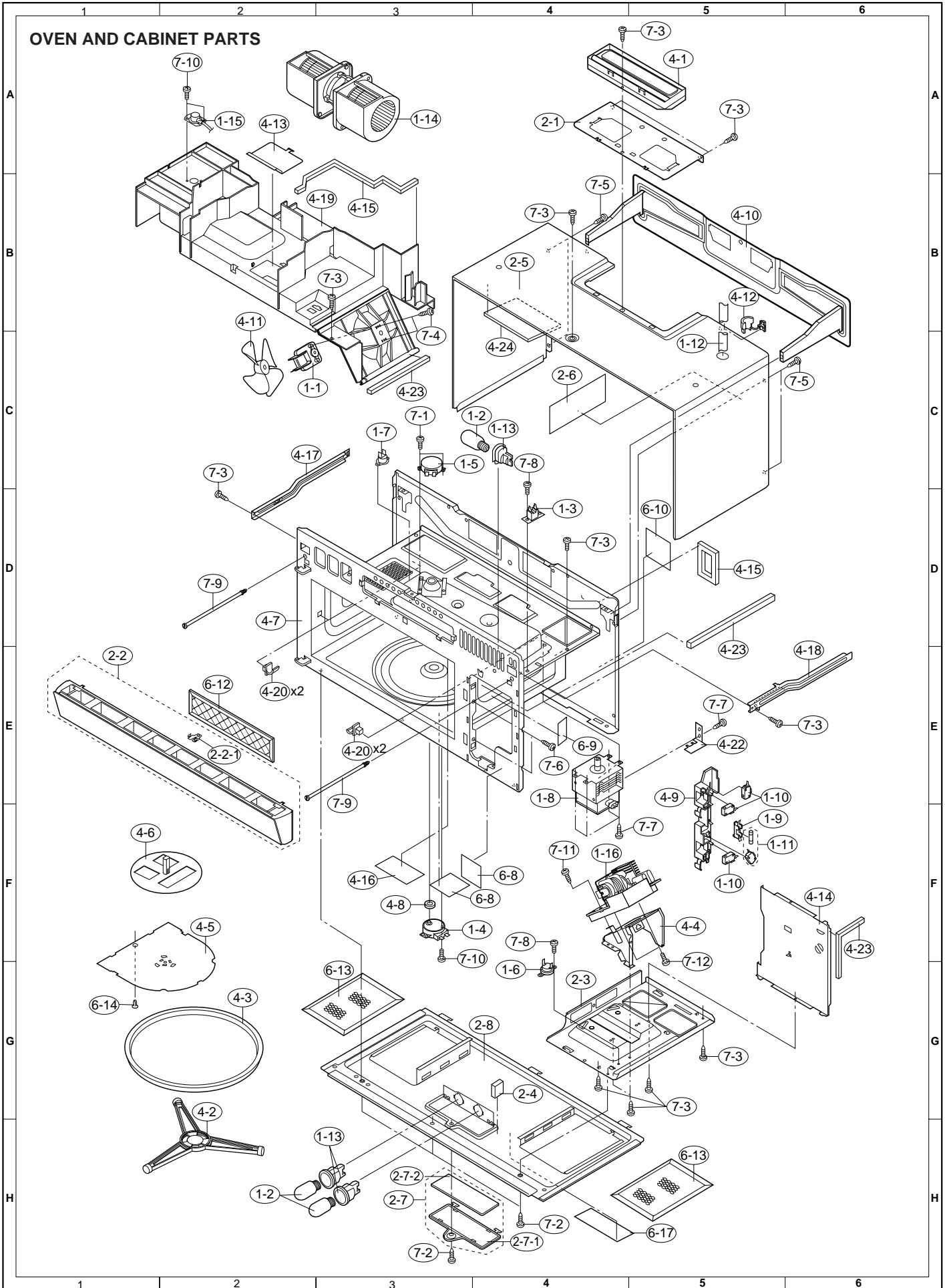

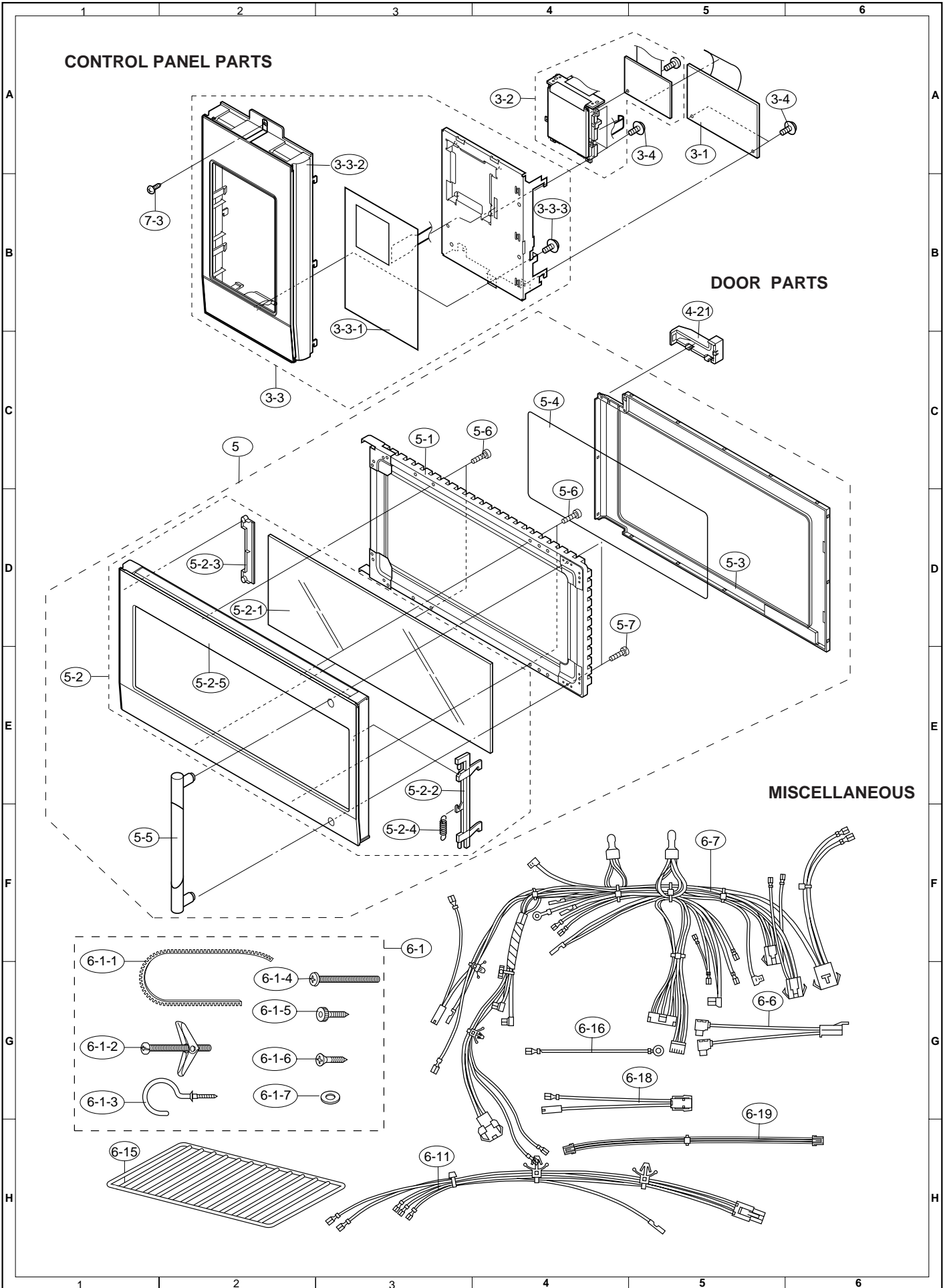

PACKING AND ACCESSORIES

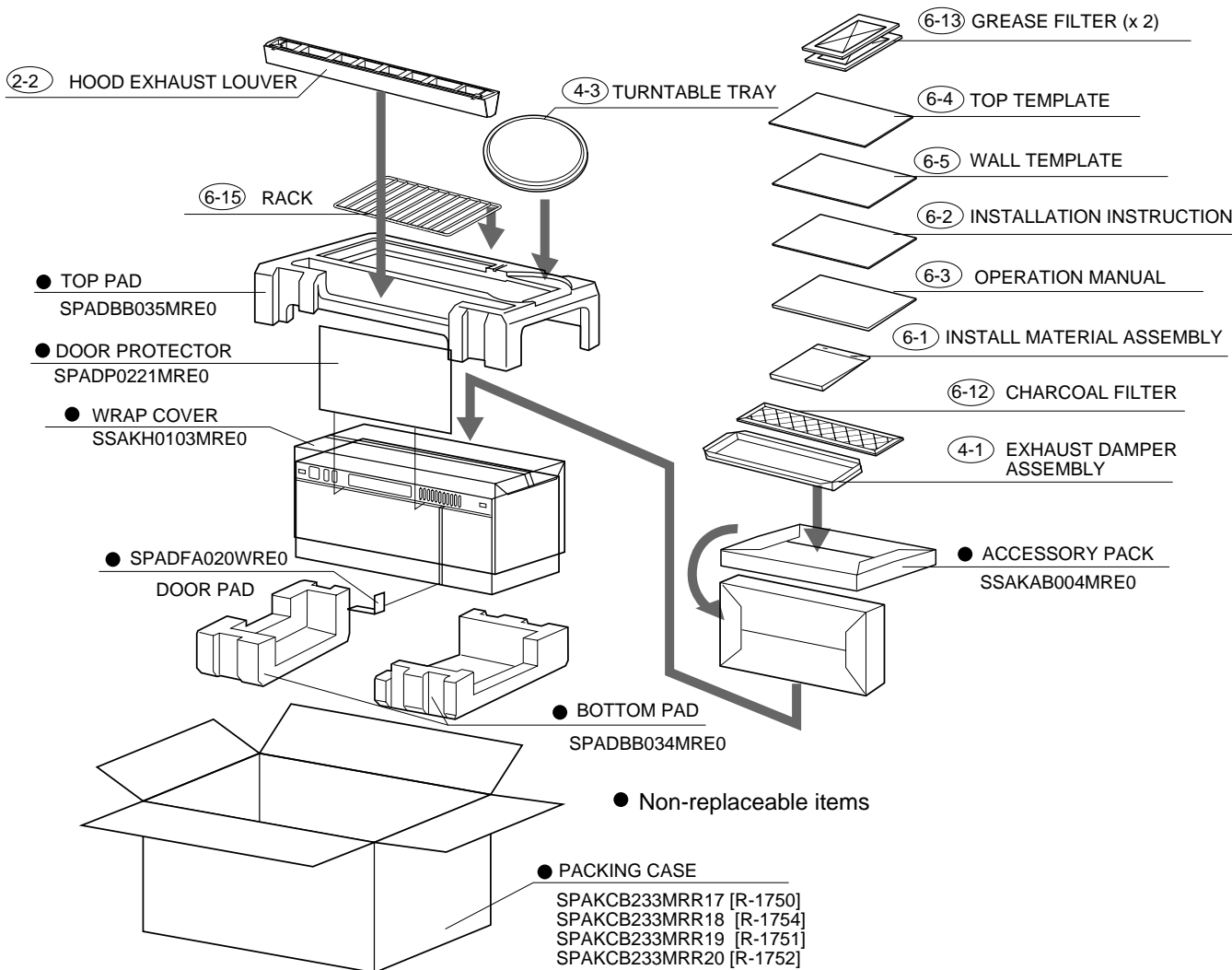

SHARP

COPYRIGHT © 2000 BY SHARP CORPORATION

ALL RIGHTS RESERVED.

No part of this publication may be reproduced, stored in retrieval systems, or transmitted in any form or by any means, electronic, mechanical, photocopying, recording, or otherwise, without prior written permission of the publisher.