

# SHARP

## SUPPLEMENTAL SERVICE MANUAL

S72M195R1514E

### OVER THE RANGE MICROWAVE OVEN

## MODEL R-1514



In the interest of user-safety the oven should be restored to its original condition and only parts identical to those specified should be used.

**WARNING TO SERVICE PERSONNEL:** Microwave ovens contain circuitry capable of producing very high voltage and current. Contact with the following parts may result in a severe, possibly fatal, electrical shock. (High Voltage Capacitor, High Voltage Power Transformer, Magnetron, High Voltage Rectifier Assembly, High Voltage Harness etc..)

This is a supplemental Service Manual for Model R-1514. This model is quite similar to base models R-1500 and R-1501. Use this supplemental manual together with the Base Models Service Manual (Reference No. is S8123R1500X//) for complete operation, service information, etc..

### TABLE OF CONTENTS

	Page
PRECAUTIONS TO BE OBSERVED BEFORE AND DURING SERVICING TO AVOID POSSIBLE EXPOSURE TO EXCESSIVE MICROWAVE ENERGY .....	INSIDE FRONT COVER
BEFORE SERVICING .....	INSIDE FRONT COVER
WARNING TO SERVICE PERSONNEL .....	1
MICROWAVE MEASUREMENT PROCEDURE .....	2
FOREWORD AND WARNING .....	3
PRODUCT SPECIFICATIONS .....	4
CONTROL PANEL .....	5
OPERATION .....	5
TROUBLESHOOTING GUIDE .....	7
TEST PROCEDURE .....	8
TOUCH CONTROL PANEL ASSEMBLY .....	14
COMPONENT REPLACEMENT AND ADJUSTMENT PROCEDURE .....	19
PICTORIAL DIAGRAM .....	22
POWER UNIT CIRCUIT .....	23
LSI UNIT CIRCUIT .....	24
PRINTED WIRING BOARD .....	25
PARTS LIST .....	26
PACKING AND ACCESSORIES .....	28

## SHARP CORPORATION

This document has been published to be used for after sales service only.

The contents are subject to change without notice.

## **PRECAUTIONS TO BE OBSERVED BEFORE AND DURING SERVICING TO AVOID POSSIBLE EXPOSURE TO EXCESSIVE MICROWAVE ENERGY**

- (a) Do not operate or allow the oven to be operated with the door open.
- (b) Make the following safety checks on all ovens to be serviced before activating the magnetron or other microwave source, and make repairs as necessary: (1) interlock operation, (2) proper door closing, (3) seal and sealing surfaces (arcing, wear, and other damage), (4) damage to or loosening of hinges and latches, (5) evidence of dropping or abuse.
- (c) Before turning on microwave power for any service test or inspection within the microwave generating compartments, check the magnetron, wave guide or transmission line, and cavity for proper alignment, integrity, and connections.
- (d) Any defective or misadjusted components in the interlock, monitor, door seal, and microwave generation and transmission systems shall be repaired, replaced, or adjusted by procedures described in this manual before the oven is released to the owner.
- (e) A microwave leakage check to verify compliance with the Federal Performance Standard should be performed on each oven prior to release to the owner.

## **BEFORE SERVICING**

Before servicing an operative unit, perform a microwave emission check as per the Microwave Measurement Procedure outlined in this service manual.

If microwave emissions level is in excess of the specified limit, contact SHARP ELECTRONICS CORPORATION immediately @1-800-237-4277.

If the unit operates with the door open, service person should 1) tell the user not to operate the oven and 2) contact SHARP ELECTRONICS CORPORATION and Food and Drug Administration's Center for Devices and Radiological Health immediately.

Service personnel should inform SHARP ELECTRONICS CORPORATION of any certified unit found with emissions in excess of  $4\text{mW}/\text{cm}^2$ . The owner of the unit should be instructed not to use the unit until the oven has been brought into compliance.

## WARNING TO SERVICE PERSONNEL

Microwave ovens contain circuitry capable of producing very high voltage and current, contact with following parts may result in a severe, possibly fatal, electrical shock.

(Example)

High Voltage Capacitor, High Voltage Power Transformer, Magnetron, High Voltage Rectifier Assembly, High Voltage Harness etc..

Read the Service Manual carefully and follow all instructions.

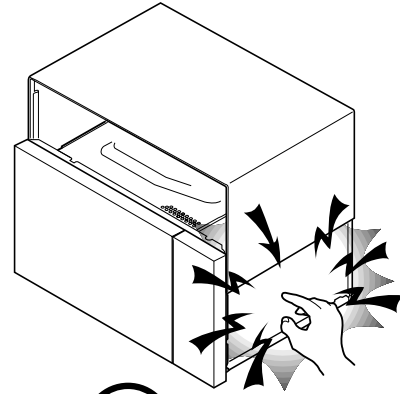

**Don't Touch !  
Danger High Voltage**

### Before Servicing

1. Disconnect the power supply cord , and then remove outer case.
2. Open the door and block it open.
3. Discharge high voltage capacitor.

**WARNING: RISK OF ELECTRIC SHOCK.  
DISCHARGE THE HIGH-VOLTAGE  
CAPACITOR BEFORE SERVICING.**

The high-voltage capacitor remains charged about 60 seconds after the oven has been switched off. Wait for 60 seconds and then short-circuit the connection of the high-voltage capacitor (that is the connecting lead of the high-voltage rectifier) against the chassis with the use of an insulated screwdriver.

Whenever troubleshooting is performed the power supply must be disconnected. It may, in some cases, be necessary to connect the power supply after the outer case has been removed, in this event,

1. Disconnect the power supply cord, and then remove outer case.
2. Open the door and block it open.
3. Discharge high voltage capacitor.
4. Disconnect the leads to the primary of the power transformer.
5. Ensure that these leads remain isolated from other components and oven chassis by using insulation tape.
6. After that procedure, reconnect the power supply cord.

### When the testing is completed,

1. Disconnect the power supply cord, and then remove outer case.
2. Open the door and block it open.
3. Discharge high voltage capacitor.
4. Reconnect the leads to the primary of the power transformer.
5. Reinstall the outer case (cabinet).
6. Reconnect the power supply cord after the outer case is installed.
7. Run the oven and check all functions.

### After repairing

1. Reconnect all leads removed from components during testing.
2. Reinstall the outer case (cabinet).
3. Reconnect the power supply cord after the outer case is installed.
4. Run the oven and check all functions.

Microwave ovens should not be run empty. To test for the presence of microwave energy within a cavity, place a cup of cold water on the oven turntable, close the door and set the power to HIGH and set the microwave timer for two (2) minutes. When the two minutes has elapsed (timer at zero) carefully check that the water is now hot. If the water remains cold carry out **Before Servicing** procedure and re-examine the connections to the component being tested.

When all service work is completed and the oven is fully assembled, the microwave power output should be checked and microwave leakage test should be carried out.

## MICROWAVE MEASUREMENT PROCEDURE

### A. Requirements:

- 1) Microwave leakage limit (Power density limit): The power density of microwave radiation emitted by a microwave oven should not exceed  $1\text{ mW/cm}^2$  at any point 5cm or more from the external surface of the oven, measured prior to acquisition by a purchaser, and thereafter (through the useful life of the oven),  $5\text{ mW/cm}^2$  at any point 5cm or more from the external surface of the oven.
- 2) Safety interlock switches: Primary interlock switch shall prevent microwave radiation emission in excess of the requirement as above mentioned, secondary interlock relay and door sensing switch shall prevent microwave radiation emission in excess of  $5\text{ mW/cm}^2$  at any point 5cm or more from the external surface of the oven.

### B. Preparation for testing:

**Before beginning the actual measurement of leakage, proceed as follows:**

- 1) Make sure that the actual instrument is operating normally as specified in its instruction booklet.

Important:

Survey instruments that comply with the requirement for instrumentation as prescribed by the performance standard for microwave ovens, 21 CFR 1030.10(c)(3)(i), must be used for testing.

- 2) Place the oven tray in the oven cavity.
- 3) Place the load of  $275\pm 15\text{ ml}$  (9.8 oz) of tap water initially at  $20\pm 5^\circ\text{C}$  ( $68^\circ\text{F}$ ) in the center of the oven cavity. The water container shall be a low form of 600 ml (20 oz) beaker with an inside diameter of approx. 8.5 cm (3-1/2 in.) and made of an electrically nonconductive material such as glass or plastic. The placing of this standard load in the oven is important not only to protect the oven, but also to insure that any leakage is measured accurately.
- 4) Set the cooking control on Full Power Cooking Mode
- 5) Close the door and select a cook cycle of several minutes. If the water begins to boil before the survey is completed, replace it with 275 ml of cool water.

### C. Leakage test:

Closed-door leakage test (microwave measurement)

- 1) Grasp the probe of the survey instrument and hold it perpendicular to the gap between the door and the body of the oven.
- 2) Move the probe slowly, not faster than 1 in./sec. (2.5 cm/sec.) along the gap, watching for the maximum indication on the meter.
- 3) Check for leakage at the door screen, sheet metal seams and other accessible positions where the continuity of the metal has been breached (eg., around the switches, indicator, and vents).  
While testing for leakage around the door pull the door away from the front of the oven as far as is permitted by the closed latch assembly.
- 4) Measure carefully at the point of highest leakage and make sure that the highest leakage is no greater than  $4\text{ mW/cm}^2$ , and that the primary interlock switch and the secondary interlock relay do turn the oven OFF before any door movement.

NOTE: After servicing, record data on service invoice and microwave leakage report.

# SERVICE MANUAL

## SHARP

OVER THE RANGE  
MICROWAVE OVEN

R-1514

### FOREWORD

This Manual has been prepared to provide Sharp Electronics Corp. Service Personnel with Operation and Service Information for the SHARP OVER THE RANGE MICROWAVE OVEN, R-1514.

The model R-1514 are quite similar to base models R-1500 and R-1501 (Reference No. is S8123R1500X/).

It is recommended that service personnel carefully study the entire text of this manual and base model service manual so that they will be qualified to render satisfactory customer service.

Check the interlock switches and the door seal carefully. Special attention should be given to avoid electrical shock and microwave radiation hazard.

#### WARNING

Never operate the oven until the following points are ensured.

- (A) The door is tightly closed.
- (B) The door brackets and hinges are not defective.
- (C) The door packing is not damaged.
- (D) The door is not deformed or warped.
- (E) There is not any other visible damage with the oven.

Servicing and repair work must be carried out only by trained service personnel.

#### DANGER

**Certain initial parts are intentionally not grounded and present a risk of electrical shock only during servicing. Service personnel - Do not contact the following parts while the appliance is energized; High Voltage Capacitor, Power Transformer, Magnetron, High Voltage Rectifier Assembly, High Voltage Harness; If provided, Vent Hood, Fan assembly, Cooling Fan Motor.**

All the parts marked “\*\*” on parts list are used at voltages more than 250V.

Removal of the outer wrap gives access to voltage above 250V.

All the parts marked “Δ” on parts list may cause undue microwave exposure, by themselves, or when they are damaged, loosened or removed.

SHARP ELECTRONICS CORPORATION

SHARP PLAZA, MAHWAH,  
NEW JERSEY 07430-2135

## PRODUCT SPECIFICATION

ITEM	DESCRIPTION
Power Requirements	120 Volts / 14 Amperes / 1600 Watts 60 Hertz Single phase, 3 wire grounded
Power Output	1000 watts (IEC TEST PROCEDURE) Operating frequency of 2450MHz
Case Dimensions	Width 29-15/16" Height 16-1/4" Depth 15- 9/16"
Cooking Cavity Dimensions 1.5 Cubic Feet	Width 17-1/2" Height 9-7/8" Depth 14-15/16"
Hood lamp	2 bulbs, 20W x 2, Incandescent light bulbs
Hood fan	Approx. 300 C.F.M.
Control Complement	Touch Control System Clock ( 1:00 - 12:59 ) Timer (0 - 99 min. 99 seconds) Microwave Power for Variable Cooking Repetition Rate; P-HI ..... Full power throughout the cooking time P-90 ..... approx. 90% of Full Power P-80 ..... approx. 80% of Full Power P-70 ..... approx. 70% of Full Power P-60 ..... approx. 60% of Full Power P-50 ..... approx. 50% of Full Power P-40 ..... approx. 40% of Full Power P-30 ..... approx. 30% of Full Power P-20 ..... approx. 20% of Full Power P-10 ..... approx. 10% of Full Power P-0 ..... No power throughout the cooking time  KEEP WARM PLUS pad, HOT WATER pad, CUSTOM HELP pad INSTANT SENSOR pads, SENSOR COOK CENTER pads REHEAT pads, DEFROST CENTER pad, Number selection pads POWER LEVEL pad, TIMER / CLOCK pad LIGHT HI / LO button, FAN HI / LO button, STOP/CLEAR button, START/ MINUTE PLUS button,
Oven Cavity Light	20W x 1 Incandescent light bulb
Safety Standard	UL Listed                      FCC Authorized DHHS Rules, CFR, Title 21, Chapter 1, Subchapter J
Weight	Approx. 55 lbs.

## CONTROL PANEL

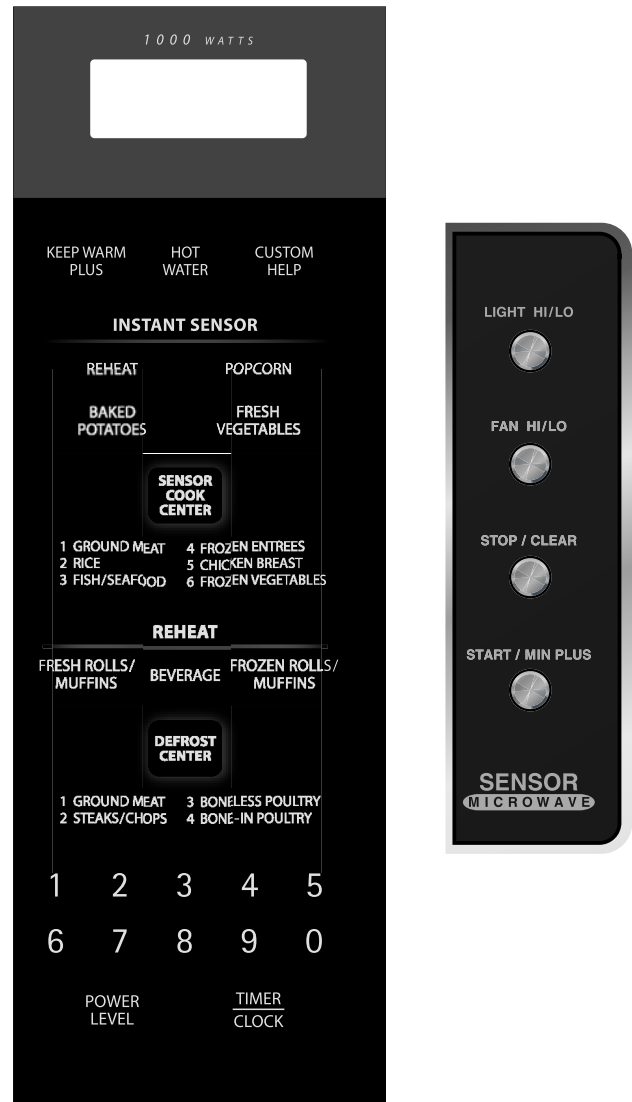

NOTE: Some one-touch cooking features such as "MINUTE PLUS" are disabled after three minutes when the oven is not used. These features are automatically enabled when the door is opened and closed or STOP/CLEAR button is pressed.

## OPERATION

### DESCRIPTION OF OPERATING SEQUENCE

The following is a description of component functions during oven operation.

#### OFF CONDITION

Closing the door activates the door sensing switch and primary interlock switch. (In this condition, the monitor switch contacts are opened.)

When oven is plugged in, 120 volts A.C. is supplied to the control unit. (Figure O-1).

1. The display will show "SHARP SIMPLY THE BEST PRESS CLEAR AND PRESS CLOCK".

To set any program or set the clock, you must first touch the STOP/CLEAR button. The display will clear, and " : " will appear .

#### POWER LEVEL P-0 TO P-90 COOKING

When Variable Cooking Power is programmed, the 120 volts A.C. is supplied to the power transformer intermittently through the contacts of relay (RY2) which is operated by the control unit within an interval second time base.

Microwave power operation is as follows:

VARI-MODE	ON TIME	OFF TIME
HIGH (100% power)	32 sec.	0 sec.
P-90 (approx. 90% power)	30 sec.	2 sec.
P-80 (approx. 80% power)	26 sec.	6 sec.
P-70 (approx. 70% power)	24 sec.	8 sec.
P-60 (approx. 60% power)	22 sec.	10 sec.
P-50 (approx. 50% power)	18 sec.	14 sec.
P-40 (approx. 40% power)	16 sec.	16 sec.
P-30 (approx. 30% power)	12 sec.	20 sec.
P-20 (approx. 20% power)	8 sec.	24 sec.
P-10 (approx. 10% power)	6 sec.	26 sec.
P-0 (0% power)	0 sec.	32 sec.

Note: The ON/OFF time ratio does not correspond with the percentage of microwave power, because approx. 3 seconds are needed for heating of the magnetron filament.

### SENSOR COOKING CONDITION

Using the Sensor Cooking function, the foods are cooked or defrosted without figuring time, power level or quantity. When the oven senses enough steam from the food, it relays the information to its microprocessor which will calculate the remaining cooking time and power level needed for best results. When the food is cooked, water vapor is developed. The sensor "senses" the vapor and its resistance increases gradually. When the resistance reaches the value set according to the menu, supplementary cooking is started. The time of supplementary cooking is determined by experiment with each food category and inputted into the LSI.

An example of how sensor works (Baked potatoes):



1. Potatoes at room temperature. Vapor is emitted very slowly.

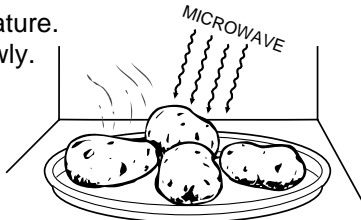

2. Heat potatoes. Moisture and humidity is emitted rapidly. You can smell the aroma as it cooks.

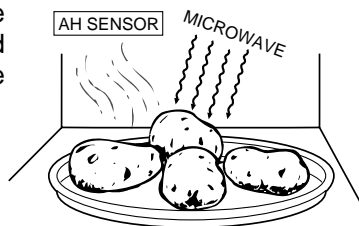

3. Sensor detects moisture and humidity and calculates cooking time and variable power.

#### Cooking Sequence.

1. Operate the oven in sensor cooking mode by referring to operation manual.

NOTE: The oven should not be operated on Sensor Cooking immediately after plugging in the unit. Wait two minutes before cooking on Sensor Cooking.

2. The coil of shut-off relay (RY1) is energized, the oven lamp, turntable motor and cooling fan motor are turned on, but the power transformer is not turned on.

3. After about 32 seconds, the cook relay (RY2) is energized. The power transformer is turned on, microwave energy is produced and first stage is started.

The 32 seconds is the cooling time required to remove any vapor from the oven cavity and sensor.

NOTE: During this first stage, do not open the door or touch STOP/CLEAR pad.

4. When the sensor detects the vapor emitted from the food, the display switches over to the remaining cooking time and the timer counts down to zero. At this time, the door may be opened to stir food, turn it or season, etc.

5. When the timer reaches zero, an audible signal sounds. The shut-off relay and cook relay are de-energized and the power transformer, oven lamp, etc. are turned off.

6. Opening the door or touching the STOP/CLEAR pad, the time of day will reappear on the display and the oven will revert to an OFF condition.

NOTE: "★" indicates components with potential above 250V.

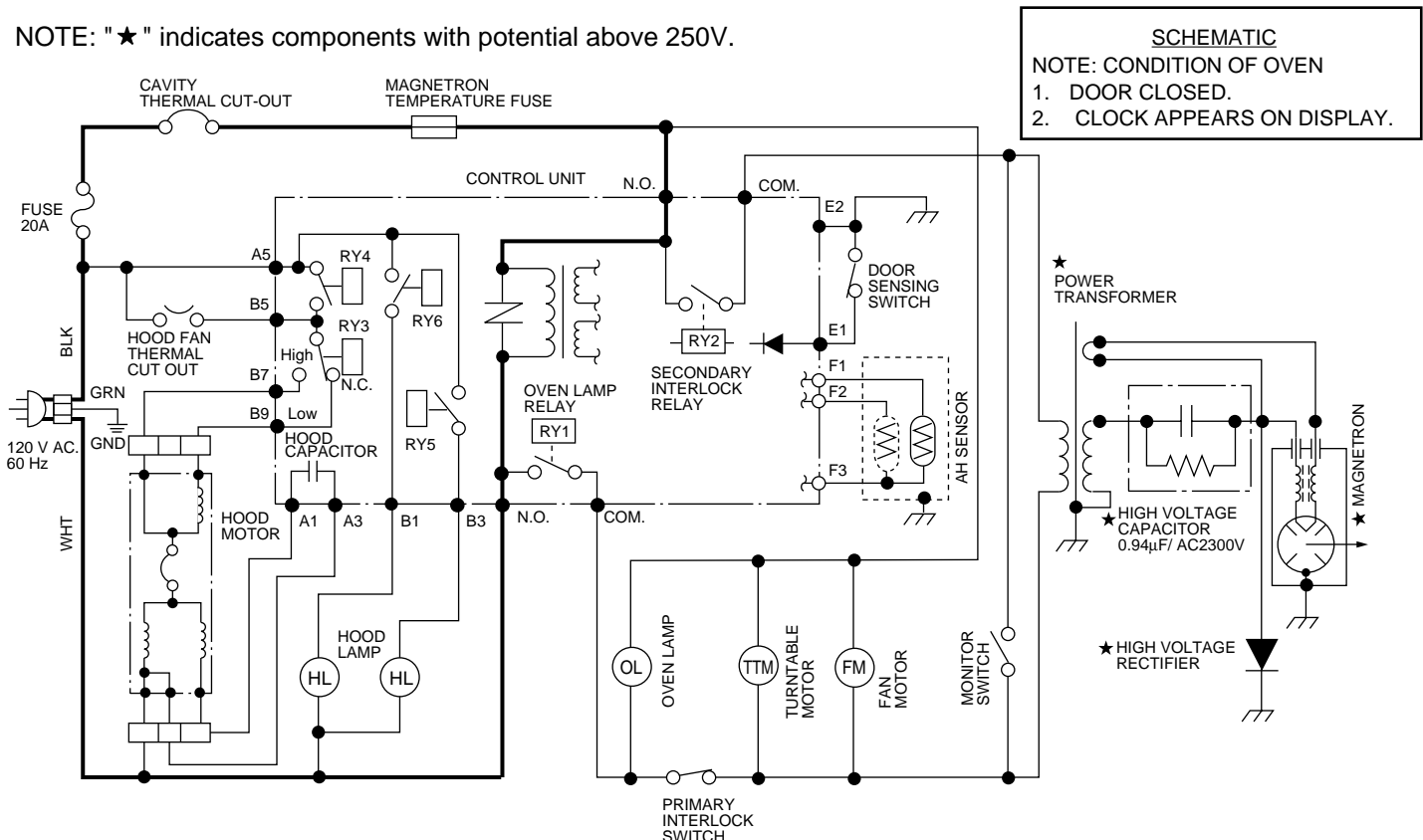
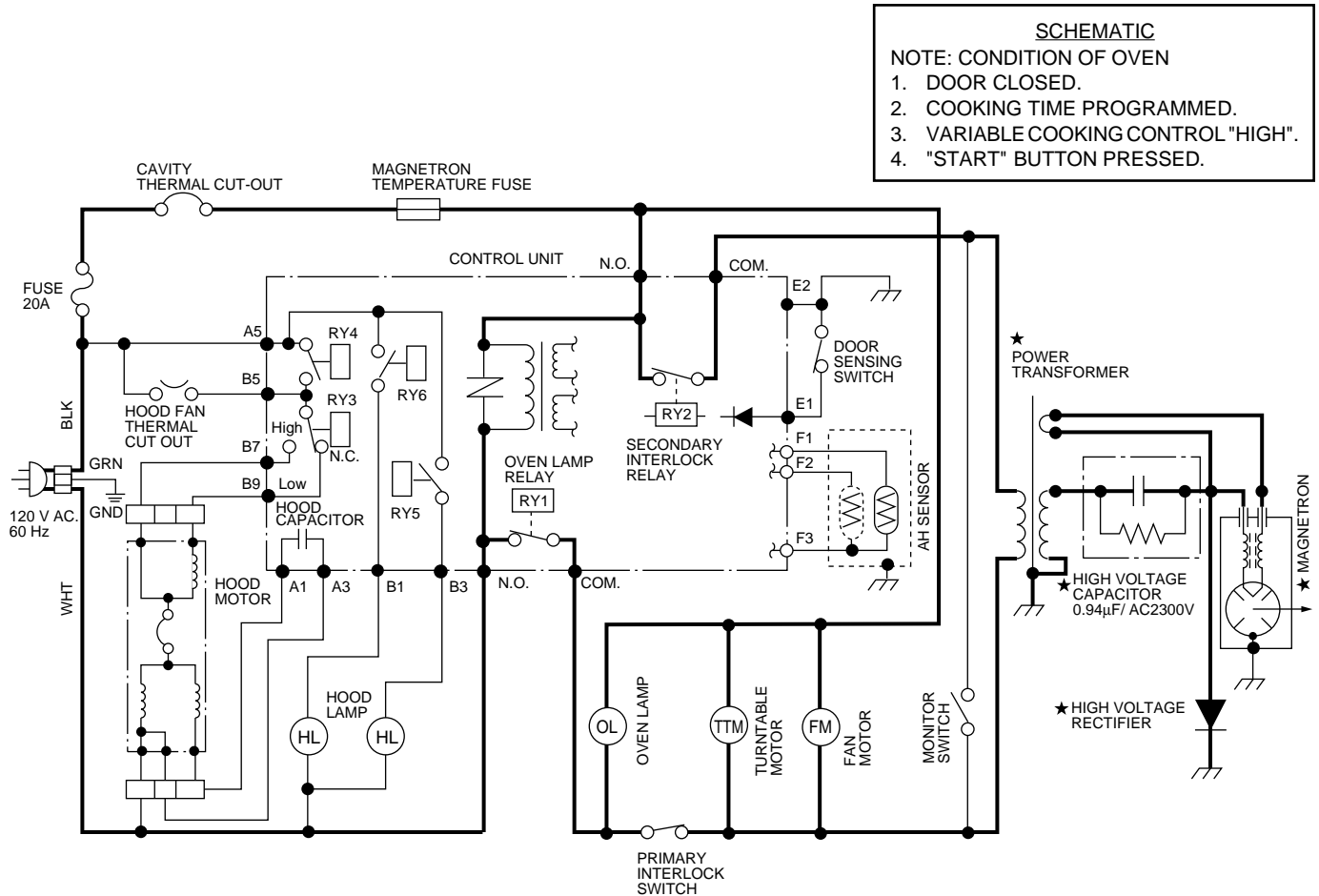

Figure O-1. Oven Schematic-Off Condition



**Figure O-2. Oven Schematic-Cooking Condition**

## TROUBLESHOOTING GUIDE

**Never touch any part in the circuit with your hand or an uninsulated tool while the power supply is connected.**

When troubleshooting the microwave oven, it is helpful to follow the Sequence of Operation in performing the checks. Many of the possible causes of trouble will require that a specific test be performed. These tests are given a procedure letter which will be found in the "Test Procedure "section.

### **IMPORTANT:**

If the oven becomes inoperative because of a blown monitor fuse, check the monitor switch, relay (RY1) secondary interlock relay (RY2), door sensing switch and primary interlock switch before replacing the monitor fuse. If monitor fuse is replaced, the monitor switch must also be replaced. Use part FFS-BA016/KiT as an assembly.

### **IMPORTANT:**

Whenever troubleshooting is performed with the power supply cord disconnected. It may in, some cases, be necessary to connect the power supply cord after the outer case has been removed, in this event,

1. Disconnect the power supply cord, and then remove outer case.
2. Open the door and block it open.
3. Discharge high voltage capacitor.
4. Disconnect the leads to the primary of the power transformer.
5. Ensure that the leads remain isolated from other components and oven chassis by using insulation tape.
6. After that procedure, reconnect the power supply cord. When the testing is completed
  1. Disconnect the power supply cord, and then remove outer case.
  2. Open the door and block it open.
  3. Discharge high voltage capacitor.
  4. Reconnect the leads to the primary of the power transformer.
  5. Reinstall the outer case (cabinet).
  6. Reconnect the power supply cord after the outer case is installed.
  7. Run the oven and check all functions.

TEST PROCEDURE		L	Q	CK
CONDITION	PROBLEM	POSSIBLE CAUSE AND DEFECTIVE PARTS		
		CONTROL UNIT	AH SENSOR	SHORTED OR OPENED WIRING
SENSOR COOKING CONDITION	The oven stops and "ERROR" is displayed or does not end during Sensor Cooking condition. (Oven does not shut off after a cup of water is boiling by Sensor Cooking.)	<input type="radio"/>	<input type="radio"/>	<input type="radio"/>
	Oven stops at 32 seconds after starting.	<input type="radio"/>	<input type="radio"/>	<input type="radio"/>

**NOTE: For additional troubleshooting procedures, please refer back to the R-1500/1501/R1505/1506 base model Service Manual.**

### TEST PROCEDURES

PROCEDURE LETTER	COMPONENT TEST
------------------	----------------

**L TOUCH CONTROL PANEL ASSEMBLY TEST**

The touch control panel consists of circuits including semiconductors such as LSI, ICs, etc. Therefore, unlike conventional microwave ovens, proper maintenance cannot be performed with only a voltmeter and ohmmeter. In this service manual, the touch control panel assembly is divided into two units, Control Unit and Key Unit, and also the Control Unit is divided into two units, LSI Unit and Power Unit, and troubleshooting by unit replacement is described according to the symptoms indicated.

**Before testing,**

- 1) Disconnect the power supply cord, and then remove outer case. Refer to procedure of "HOOD EXHAUST LOUVER REMOVAL", "REMOVAL OF OVEN FROM WALL" and "OUTER CASE REMOVAL".
- 2) Open the door and block it open.
- 3) To discharge high voltage capacitor, wait for 60 seconds.
- 4) Remove two (2) screws holding the hood intake duct R to the oven cavity top plate and the base plate R. And remove the hood intake duct R.
- 5) Disconnect the leads to the primary of the power transformer.
- 6) Ensure that these leads remain isolated from other components and oven chassis by using insulation tape.

1. Key Unit.

NOTE ;

- 1) Check key unit ribbon connection before replacement.
- 2) Re-install the hood intake duct R with two (2) screws.
- 3) Re-install the outer case (cabinet).
- 4) Reconnect the power supply cord after the outer case is installed.
- 5) Run the oven and check all functions.

The following symptoms indicate a defective key unit.

- a) When touching the pads, a certain pad produces no signal at all.
  - b) When touching a number pad, two figures or more are displayed.
  - c) When touching the pads, sometimes a pad produces no signal.
- If the key unit is defective.

- 1) Disconnect the power supply cord, and then remove outer case.
- 2) Open the door and block it open.

## TEST PROCEDURES

PROCEDURE LETTER	COMPONENT TEST
	<ol style="list-style-type: none"> <li>3) To discharge high voltage capacitor, wait for 60 seconds.</li> <li>4) Replace the key unit.</li> <li>5) Reconnect all leads removed from components during testing.</li> <li>6) Re-install the outer case (cabinet).</li> <li>7) Reconnect the power supply cord after the outer case is installed.</li> <li>8) Run the oven and check all functions.</li> </ol>
	<p>2. Control Unit.</p> <p>The following symptoms indicate a defective control unit. Before replacing the control unit, perform the Key unit test (Procedure M) to determine if control unit is faulty.</p>
	<p>2-1 In connection with pads.</p> <ol style="list-style-type: none"> <li>a) When touching the pads, a certain group of pads do not produce a signal.</li> <li>b) When touching the pads, no pads produce a signal.</li> </ol>
	<p>2-2 In connection with indicators</p> <ol style="list-style-type: none"> <li>a) At a certain digit, all or some segments do not light up.</li> <li>b) At a certain digit, brightness is low.</li> <li>c) Only one indicator does not light.</li> <li>d) The corresponding segments of all digits do not light up; or they continue to light up.</li> <li>e) Wrong figure appears.</li> <li>f) A certain group of indicators do not light up.</li> <li>g) The figure of all digits flicker.</li> </ol>
	<p>2-3 Other possible problems caused by defective control unit.</p> <ol style="list-style-type: none"> <li>a) Buzzer does not sound or continues to sound.</li> <li>b) Clock does not operate properly.</li> <li>c) Cooking is not possible.</li> </ol>
	<p>When testing is completed,</p> <ol style="list-style-type: none"> <li>1) Disconnect the power supply cord.</li> <li>2) Open the door and block it open.</li> <li>3) To discharge high voltage capacitor, wait for 60 seconds.</li> <li>4) Reconnect all leads removed from components during testing.</li> <li>5) Re-install the hood intake duct R.</li> <li>6) Re-install the outer case (cabinet).</li> <li>7) Reconnect the power supply cord after the outer case is installed.</li> <li>8) Run the oven and check all functions.</li> </ol>

---

### **M**      **KEY UNIT TEST**

1. Disconnect the power supply cord.
2. Open the door and block it open.
3. To discharge high voltage capacitor, wait for 60 seconds.
4. Remove the control panel assembly.
5. If the display fails to clear when the STOP/CLEAR pad is depressed, first verify the flat ribbon cable is making good contact, verify that the door sensing switch operates properly; that is the contacts are closed when the door is closed and open when the door is open. If the door sensing switch is good, disconnect the flat ribbon cable that connects the key unit to the control unit and make sure the door sensing switch is closed (either close the door or short the door sensing switch connector). Use the Key unit matrix indicated on the control panel schematic and place a jumper wire between the pins that correspond to the STOP/CLEAR pad making momentary contact. If the control unit responds by clearing with a beep the key unit is faulty and must be replaced. If the control unit does not respond, it is faulty and must be replaced. If a specific pad does not respond, the above method may be used (after clearing the control unit) to determine if the control unit or key pad is at fault.
6. Reconnect all leads removed from components during testing.
7. Re-install the control panel assembly.
8. Reconnect the power supply cord.
9. Run the oven and check all functions.

## TEST PROCEDURES

**PROCEDURE LETTER**

**COMPONENT TEST**

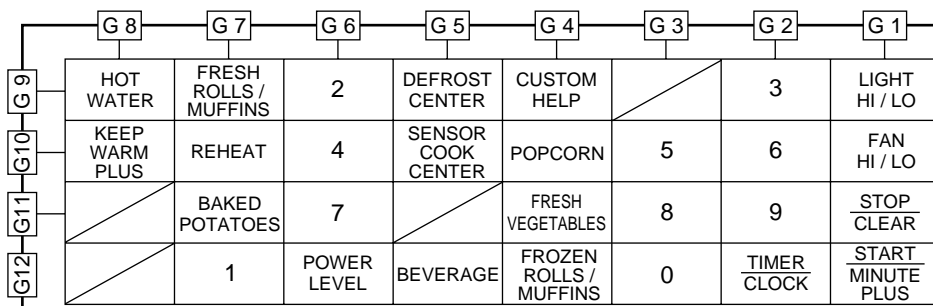

**N RELAY TEST**

1. Disconnect the power supply cord, and then remove outer case. Refer to procedure of " HOOD EXHAUST LOUVER REMOVAL ", " REMOVAL OF OVEN FROM WALL " and " OUTER CASE REMOVAL ".
2. Open the door and block it open.
3. To discharge high voltage capacitor, wait for 60 seconds.
4. Remove the hood intake duct R.
5. Disconnect the leads to the primary of the power transformer.
6. Ensure that these leads remain isolated from other components and oven chassis by using insulation tape.
7. After that procedure, re-connect the power supply cord.
8. Check voltage between normal open terminal of the relay RY2 and the normal open terminal of the relay RY1 on the control unit with an A.C. voltmeter.

The meter should indicate 120 volts, if not check oven circuit.

**RY1, RY2, RY3, RY4, RY5 and RY6 Relay Test**

These relays are operated by D.C. voltage

Check voltage at the relay coil with a D.C. voltmeter during the microwave cooking operation.

DC. voltage indicated ..... Defective relay.

DC. voltage not indicated ..... Check diode which is connected to the relay coil. If diode is good, control unit is defective.

RELAY SYMBOL	OPERATIONAL VOLTAGE	CONNECTED COMPONENTS
RY1	Approx. 25.0V D.C.	Oven lamp / Fan motor / Turntable motor
RY2(COOK)	Approx. 24.5V D.C.	Power transformer
RY3	Approx. 25.0V D.C.	Hood motor
RY4	Approx. 25.0V D.C.	Hood motor
RY5	Approx. 25.0V D.C.	Hood lamp
RY6	Approx. 25.0V D.C.	Hood lamp

9. Disconnect the power supply cord.
10. Open the door and block it open.
11. To discharge high voltage capacitor, wait for 60 seconds.
12. Reconnect all leads removed from components during testing.
13. Re-install the hood intake duct R.
14. Re-install the outer case (cabinet).
15. Reconnect the power supply cord after the outer case is installed.

**O DEFROST CENTER TEST**

- (1) Open the door.
- (2) Place one cup of water in the center of the turntable tray in the oven cavity.
- (3) Touch the " DEFROST CENTER " pad once. And then touch the number pad " 2 ".
- (4) Touch the number pad " 5 ".
- (5) Close the door.
- (6) Touch the " START " button.
- (7) The oven is in Defrost center cooking condition.

## TEST PROCEDURES

PROCEDURE LETTER	COMPONENT TEST
------------------	----------------

(8) The oven will operate as follows.

Menu	1ST STAGE		2ND STAGE	
	LEVEL	TIME	LEVEL	TIME
0.5lbs	60%	57sec.	40%	17sec.

(9) If improper operation is indicated, the control unit is probably defective and should be checked.

### P FOIL PATTERN ON THE PRINTED WIRING BOARD TEST

To protect the electronic circuits, this model is provided with a fine foil pattern added to the primary on the PWB, this foil pattern acts as a fuse.

1. Foil pattern check and repairs.

- 1) Disconnect the power supply cord.
- 2) Open the door and block it open.
- 3) To discharge high voltage capacitor, wait for 60 seconds.
- 4) Remove the control unit, referring to the procedure of " CONTROL PANEL ASSEMBLY, CONTROL UNIT AND KEY UNIT REMOVAL ".
- 5) Follow the troubleshooting guide given below for repair.

STEPS	OCCURRENCE	CAUSE OR CORRECTION
1	Only pattern at "a" is broken.	*Insert jumper wire J1 and solder.
2	Pattern at "a" and "b" are broken.	*Insert the coil RCILF2003YAZZ between "c" and "d".

- 6) Make a visual inspection of the varistor. Check for burned damage and examine the transformer with a tester for the presence of layer short-circuit (check the primary coil resistance which is approximately  $780\Omega \pm 10\%$ ). If any abnormal condition is detected, replace the defective parts.

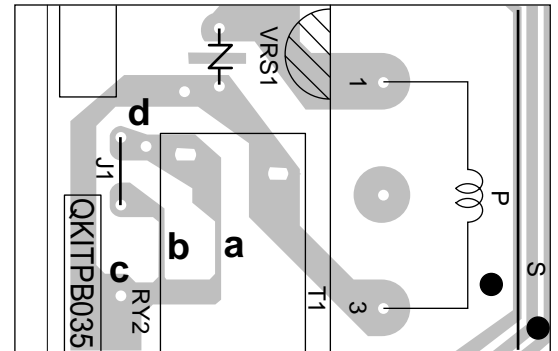

- 7) Reconnect all leads removed from components during testing.
  - 8) Re-install the control unit to the control panel and re-install the control panel to the oven.
  - 9) Reconnect the power supply cord.
  - 10) Run the oven and check all functions.
2. Follow the troubleshooting guide given below, if indicator does not light up after above check and repairs are finished.
- 1) Disconnect the power supply cord, and then remove outer case. Refer to procedure of " HOOD EXHAUST LOUVER REMOVAL ", " REMOVAL OF OVEN FROM WALL " and " OUTER CASE REMOVAL ".
  - 2) Open the door and block it open.
  - 3) To discharge high voltage capacitor, wait for 60 seconds.
  - 4) Remove the hood intake duct R.
  - 5) Disconnect the leads to the primary of the power transformer.
  - 6) Ensure that these leads remain isolated from other components and oven chassis by using insulation tape.
  - 7) After that procedure, re-connect the power supply cord.
  - 8) Follow the troubleshooting guide given below for repair.

STEPS	OCCURRENCE	CAUSE OR CORRECTION
1	The rated AC voltage is not present between the normal open terminal of the relay RY2 and the normal open terminal of the relay RY1.	Check supply voltage and oven power cord.
2	The rated AC voltage is present at primary side of low voltage transformer.	Low voltage transformer or secondary circuit defective. Check and repair.

## TEST PROCEDURES

PROCEDURE LETTER	COMPONENT TEST
	9) Disconnect the power supply cord. 10) Open the door and block it open. 11) To discharge high voltage capacitor, wait for 60 seconds. 12) Reconnect all leads removed from components during testing. 13) Re-install the hood intake duct R. 14) Re-install the outer case (cabinet). 15) Reconnect the power supply cord after the outer case is installed. 16) Run the oven and check all functions.

### Q AH SENSOR TEST

#### **Checking the initial sensor cooking condition**

**WARNING :** The oven should be fully assembled before following procedure.

- (1) The oven should be plugged in at least two minutes before sensor cooking.
- (2) Room temperature should not exceed 95°F (35°C).
- (3) The unit should not be installed in any area where heat and steam are generated. The unit should not be installed, for example, next to a conventional surface unit. Refer to the "INSTALLATION INSTRUCTIONS" of the operation manual.
- (4) Exhaust vents are provided on the back of the unit for proper cooling and air flow in the cavity. To permit adequate ventilation, be sure to install so as not to block these vents. There should be some space for air circulation.
- (5) Be sure the exterior of the cooking container and the interior of the oven are dry. Wipe off any moisture with a dry cloth or paper towel.
- (6) The Sensor works with food at normal storage temperature. For example, chicken pieces would be at refrigerator temperature and canned soup at room temperature.
- (7) Avoid using aerosol sprays or cleaning solvents near the oven while using Sensor settings. The sensor will detect the vapor given off by the spray and turn off before food is properly cooked.
- (8) If the sensor has not detected the vapor of the food, ERROR will appear and the oven will shut off.

#### **Water load cooking test**

**WARNING :** The oven should be fully assembled before following procedure.

Make sure the oven has been plugged in at least two minutes before checking sensor cook operation. The cabinet should be installed and screws tightened.

- (1) Fill approximately 200 milliliters (7.2 oz) of tap water in a 1000 milliliter measuring cup.
- (2) Place the container on the center of tray in the oven cavity.
- (3) Close the door.
- (4) Touch the TIMER/CLOCK once, the POWER LEVEL pad twice, the START pad once, the number pad 1 once and the number pad 4 once. Now, the oven is in the sensor cooking condition, and "AH20", "SENSOR" and "COOK" will appear in the display.
- (5) The oven will operate for the first 32 seconds, without generating microwave energy.

NOTE: ERROR will appear if the door is opened or STOP/CLEAR pad is touched during first stage of sensor cooking.

- (6) After approximately 32 seconds, microwave energy is produced.

If ERROR is displayed or the oven does not turn off, replace the AH sensor or check the control unit, refer to explanation below. If the oven stops after 5 minutes and ERROR is displayed, the AH sensor is normal. Check other parts except the AH sensor.

#### **TESTING METHOD FOR AH SENSOR AND/OR CONTROL UNIT**

To determine if the sensor is defective, the simplest method is to replace it with a new replacement sensor.

- (1) Disconnect the power supply cord, and then remove outer case.
- (2) Open the door and block it open.
- (3) Discharge high voltage capacitor.
- (4) Remove the AH sensor.
- (5) Install the new AH sensor.
- (6) Reconnect all leads removed from components during testing.

## TEST PROCEDURES

PROCEDURE LETTER	COMPONENT TEST
	<p>(7) Re-install the outer case (cabinet).</p> <p>(8) Reconnect the power supply cord after the outer case is installed.</p> <p>(9) Reconnect the oven to the power supply and check the sensor cook operation as follows:</p> <p style="padding-left: 20px;">9-1. Fill approximately 200 milliliters (7.2 oz) of tap water in a 1000 milliliter measuring cup.</p> <p style="padding-left: 20px;">9-2. Place the container on the center of tray in the oven cavity.</p> <p style="padding-left: 20px;">9-3. Close the door.</p> <p style="padding-left: 20px;">9-4. Touch the TIMER/CLOCK pad once, the POWER LEVEL pad twice, the START pad once, the number pad 1 once and the number pad 4 once.</p> <p style="padding-left: 20px;">9-5. The control panel is in automatic Sensor operation.</p> <p style="padding-left: 20px;">9-6. The oven turns off automatically, and the time for detecting moisture will be displayed.</p> <p>If new sensor dose not operate properly, the problem is with the control unit, and refer to explanation below.</p>

### CHECKING CONTROL UNIT

- (1) Disconnect the power supply cord, and then remove outer case.
- (2) Open the door and block it open.
- (3) Discharge high voltage capacitor.
- (4) Disconnect the sensor connector that is mounted to control panel.
- (5) Then connect the dummy resistor circuit (see fig.) to the sensor connector of control panel.
- (6) Disconnect the leads to the primary of the power transformer.
- (7) Ensure that these leads remain isolated from other components and oven chassis by using insulation tape.
- (8) After that procedure, re-connect the power supply cord.
- (9) Check the sensor cook operation proceed as follows:
  - 9-1. Touch the TIMER/CLOCK pad once, the POWER LEVEL pad twice, the START pad once and the number pad 1 once and the number pad 4 once.
  - 9-2. The control panel is in the sensor cooking operation.
  - 9-3. After approximately 65 seconds, push plunger of select switch for more than 3 seconds. This condition is same as judgement by AH sensor.
  - 9-4. After approximately 3 seconds, the display shows " X X . X X " which is the time for detecting moisture.

If the above is not the case, the control unit is probably defective.

If the above is proper, the AH sensor is probably defective.
- (10) Disconnect the power supply cord, and then remove outer case.
- (11) Open the door and block it open.
- (12) Discharge high voltage capacitor.
- (13) Disconnect the dummy resistor circuit from the sensor connector of control panel.
- (14) Carry out necessary repair.
- (15) Reconnect all leads removed from components during testing and repairing.
- (16) Re-install the outer case (cabinet).
- (17) Reconnect the power supply cord after the outer case is installed. Run the oven and check all functions.
- (18) Carry out "Water load cooking test" again and ensure that the oven works properly.

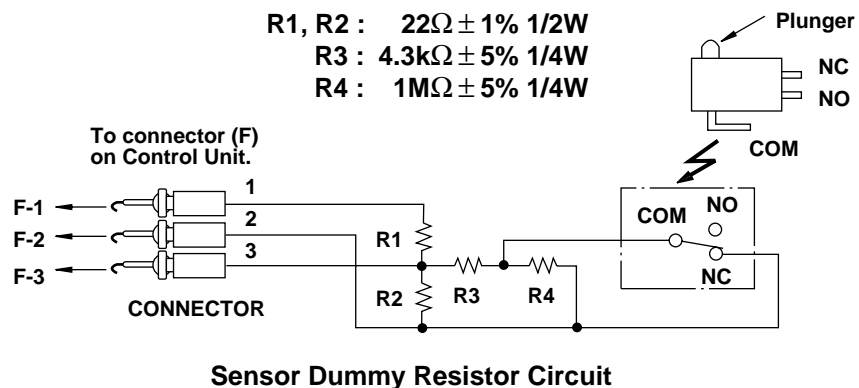

# TOUCH CONTROL PANEL ASSEMBLY

## OUTLINE OF TOUCH CONTROL PANEL

The touch control section consists of the following units as shown in the touch control panel circuit.

- (1) Key Unit
- (2) Control Unit (The Control unit consists of LSI Unit and Power U nit)

The principal functions of these units and the signals communicated among them are explained below.

### Key Unit

The key unit is composed of a matrix, signals generated in the LSI are sent to the key unit through P20, P21, P22, P23, P24, P25, P26 and P27.

When a key pad is touched, a signal is completed through the key unit and passed back to the LSI through P43, P44, P45 and P46 to perform the function that was requested.

### Control Unit

Control unit consists of LSI, power source circuit, synchronizing signal circuit, reset circuit, buzzer circuit, relay circuit indicator circuit, back light circuit and absolute humidity sensor circuit.

#### 1) LSI

This LSI controls the key strobe signal, relay driving signal for oven function and indicator signal.

#### 2) Power Source Circuit

This circuit generates voltages necessary for the control unit from the AC line voltage.

In addition, the synchronizing signal is available in order to compose a basic standard time in the clock circuit.

Symbol	Voltage	Application
VC	-5.3V	LSI(IC1)

#### 3) Synchronizing Signal Circuit

The power source synchronizing signal is available in order to compose a basic standard time in the clock circuit. It incorporates a very small error because it works on commercial frequency.

#### 4) Reset Circuit

A circuit to generate a signals which resetting the LSI to the initial state when power is applied.

#### 5) Buzzer Circuit

The buzzer is responds to signals from the LSI to emit audible sounds (key touch sound and completion sound).

#### 6) Door Sensing Switch

A switch to inform the LSI if the door is open or closed.

#### 7) Relay Circuit

To drive the magnetron, fan motor, turntable motor, hood motor, and light the oven lamp and hood lamp.

#### 8) Indicator Circuit

This circuit consists of 25 segments and 4 common electrodes using a Light Crystal Display.

#### 9) Back Light Circuit

A circuit to drive the back light (Light emitting diodes LD1-LD4).

#### 10) Absolute Humidity Sensor Circuit

This circuit detects moisture of the cooking food to allow its automatic cooking.



## DESCRIPTION OF LSI

### LSI

The I/O signal of the LSI is detailed in the following table.

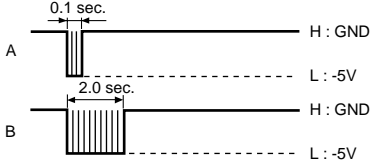
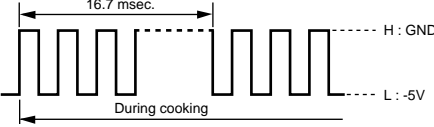
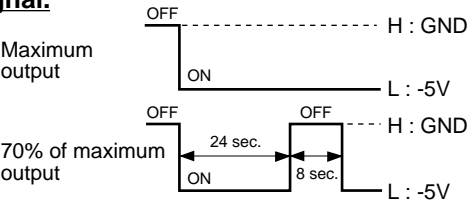
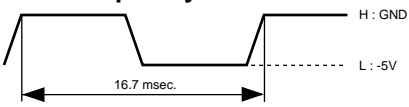
Pin No.	Signal	I/O	Description
1-2	VL2-VL1	IN	<b>Power source voltage input terminal.</b> Standard voltage for LCD.
3-6	AN7-AN4	IN	<b>Terminal to change cooking input according to the Model.</b> By using the A/D converter contained in the LSI, DC voltage in accordance with the Model in operation is applied to set up its cooking constant.
7	AN3	OUT	Back light circuit (Light emitting diodes) driving signal.
8	AN2	IN	<b>To input signal which communicates the door open/close information to LSI.</b> Door close "H" level signal (0V). Door open "L" level signal (-5V).
9	AN1	IN	<b>AH sensor input..</b> This input is an analog input terminal from the AH sensor circuit, and connected to the A/D converter built into the LSI.

Pin No.	Signal	I/O	Description
10	AN0	IN	Used for initial balancing of the bridge circuit (absolute humidity sensor). This input is an analog input terminal from the AH sensor circuit, and connected to the A/D converter built into the LSI.
11-13	P57-P55	OUT	Used for initial balancing of the bridge circuit (absolute humidity sensor).
14	CNTR0	OUT	<p><b>Signal to sound buzzer (2.0 kHz).</b></p> <p>A: key touch sound.</p> <p>B: Completion sound.</p> 
15	P53	OUT	Used for initial balancing of the bridge circuit (absolute humidity sensor).
16	P52	OUT	<p><b>Oven lamp, fan motor and turntable motor driving signal</b></p> <p>To turn on and off shut off relay (RY1). The square waveform voltage is delivered to the RY1 driving circuit and RY2 control circuit.</p> 
17	P51	OUT	Used for initial balancing of the bridge circuit (absolute humidity sensor).
18	P50	OUT	Terminal not used.
19	P47	OUT	<p><b>Magnetron high-voltage circuit driving signal.</b></p> <p>To turn on and off the cook relay (RY2). The signals holds "L" level during microwave cooking and "H" level while not cooking. In other cooking modes (variable cooking) the signal turns to "H" level and "L" level in repetition according to the power level.</p> 
20	P46	IN	<p><b>Signal coming from touch key.</b></p> <p>When either G12 line on key matrix is touched, a corresponding signal out of P20 - P27 will be input into P46. When no key is touched, the signal is held at "H" level.</p>
21	P45	IN	<p><b>Signal similar to P46.</b></p> <p>When either G11 line on key matrix is touched, a corresponding signal will be input into P45.</p>
22	P44	IN	<p><b>Signal similar to P46.</b></p> <p>When either G10 line on key matrix is touched, a corresponding signal will be input into P44.</p>
23	P43	IN	<p><b>Signal similar to P46.</b></p> <p>When either G9 line on key matrix is touched, a corresponding signal will be input into P43.</p>
24	INT0	IN	<p><b>Signal synchronized with commercial power source frequency.</b></p> <p>This is the basic timing for time processing of LSI.</p> 
25	P41	OUT	Terminal not used.
26	P40	IN	Connected to GND through the pull-down resistor R100.
27	$\overline{\text{RESET}}$	IN	<p><b>Auto clear terminal.</b></p> <p>Signal is input to reset the LSI to the initial state when power is applied.</p>
28-29	P71-P70	OUT	Terminal not used.
30	XIN	IN	<p><b>Internal clock oscillation frequency input setting.</b></p> <p>The internal clock frequency is set by inserting the ceramic filter oscillation circuit with respect to XOUT terminal.</p>
31	XOUT	OUT	<p><b>Internal clock oscillation frequency control output.</b></p> <p>Output to control oscillation input of XIN.</p>
32	VSS	IN	<p><b>Power source voltage: -5.0V.</b></p> <p>VC voltage of power source circuit input.</p>
33	P27	OUT	<p><b>Key strobe signal.</b></p> <p>Signal applied to touch-key section. A pulse signal is input to P43-P46 terminal while one of G8 line keys on key matrix is touched.</p>

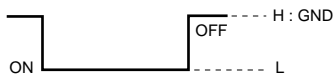
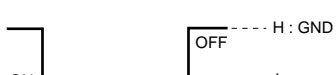
Pin No.	Signal	I/O	Description																																																								
34	P26	OUT	<b>Key strobe signal.</b> Signal applied to touch-key section. A pulse signal is input to P43-P46 terminal while one of G7 line keys on key matrix is touched.																																																								
35	P25	OUT	<b>Key strobe signal.</b> Signal applied to touch-key section. A pulse signal is input to P43-P46 terminal while one of G6 line keys on key matrix is touched.																																																								
36	P24	OUT	<b>Key strobe signal.</b> Signal applied to touch-key section. A pulse signal is input to P43-P46 terminal while one of G5 line keys on key matrix is touched.																																																								
37	P23	OUT	<b>Key strobe signal.</b> Signal applied to touch-key section. A pulse signal is input to P43-P46 terminal while one of G4 line keys on key matrix is touched.																																																								
38	P22	OUT	<b>Key strobe signal.</b> Signal applied to touch-key section. A pulse signal is input to P43-P46 terminal while one of G3 line keys on key matrix is touched.																																																								
39	P21	OUT	<b>Key strobe signal.</b> Signal applied to touch-key section. A pulse signal is input to P43-P46 terminal while one of G2 line keys on key matrix is touched.																																																								
40	P20	OUT	<b>Key strobe signal.</b> Signal applied to touch-key section. A pulse signal is input to P43-P46 terminal while one of G1 line keys on key matrix is touched.																																																								
41	P17	OUT	<b>Hood lamp driving signal.</b> To turn on and off relay(RY6). "L" level: During Hood lamp ON. "H" level: During Hood lamp OFF.																																																								
42	P16	OUT	<b>Hood lamp driving signal.</b> To turn on and off relay(RY5). "L" level: During Hood lamp ON. "H" level: During Hood lamp OFF.																																																								
43	P15	OUT	<b>Hood motor high / low driving signal.</b> To turn on and off relay(RY3). "L" level: During Hood motor high. "H" level: During Hood motor low.																																																								
44	P14	OUT	<b>Hood motor driving signal.</b> To turn on and off relay(RY4). "L" level: During Hood motor ON. "H" level: During Hood motor OFF.																																																								
45-47	P13-P11	OUT	Terminal not used.																																																								
48-72	SEG24-SEG0	OUT	<b>Segment data signal.</b> Connected to LCD.  The relation between signals are as follows:  <table border="0" style="width: 100%; border-collapse: collapse;"> <thead> <tr> <th>LSI signal (Pin No.)</th> <th>LCD (Pin No.)</th> <th>LSI signal (Pin No.)</th> <th>LCD (Pin No.)</th> </tr> </thead> <tbody> <tr><td>SEG 24 (48)</td><td>SEG24 (29)</td><td>SEG 11 (61)</td><td>SEG11 (16)</td></tr> <tr><td>SEG 23 (49)</td><td>SEG23 (28)</td><td>SEG 10 (62)</td><td>SEG10 (15)</td></tr> <tr><td>SEG 22 (50)</td><td>SEG22 (27)</td><td>SEG 9 (63)</td><td>SEG 9 (14)</td></tr> <tr><td>SEG 21 (51)</td><td>SEG21 (26)</td><td>SEG 8 (64)</td><td>SEG 8 (13)</td></tr> <tr><td>SEG 20 (52)</td><td>SEG20 (25)</td><td>SEG 7 (65)</td><td>SEG 7 (12)</td></tr> <tr><td>SEG 19 (53)</td><td>SEG19 (24)</td><td>SEG 6 (66)</td><td>SEG 6 (11)</td></tr> <tr><td>SEG 18 (54)</td><td>SEG18 (23)</td><td>SEG 5 (67)</td><td>SEG 5 (10)</td></tr> <tr><td>SEG 17 (55)</td><td>SEG17 (22)</td><td>SEG 4 (68)</td><td>SEG 4 ( 9)</td></tr> <tr><td>SEG 16 (56)</td><td>SEG16 (21)</td><td>SEG 3 (69)</td><td>SEG 3 ( 8)</td></tr> <tr><td>SEG 15 (57)</td><td>SEG15 (20)</td><td>SEG 2 (70)</td><td>SEG 2 ( 7)</td></tr> <tr><td>SEG 14 (58)</td><td>SEG14 (19)</td><td>SEG 1 (71)</td><td>SEG 1 ( 6)</td></tr> <tr><td>SEG 13 (59)</td><td>SEG13 (18)</td><td>SEG 0 (72)</td><td>SEG 0 ( 5)</td></tr> <tr><td>SEG 12 (60)</td><td>SEG12 (17)</td><td></td><td></td></tr> </tbody> </table>	LSI signal (Pin No.)	LCD (Pin No.)	LSI signal (Pin No.)	LCD (Pin No.)	SEG 24 (48)	SEG24 (29)	SEG 11 (61)	SEG11 (16)	SEG 23 (49)	SEG23 (28)	SEG 10 (62)	SEG10 (15)	SEG 22 (50)	SEG22 (27)	SEG 9 (63)	SEG 9 (14)	SEG 21 (51)	SEG21 (26)	SEG 8 (64)	SEG 8 (13)	SEG 20 (52)	SEG20 (25)	SEG 7 (65)	SEG 7 (12)	SEG 19 (53)	SEG19 (24)	SEG 6 (66)	SEG 6 (11)	SEG 18 (54)	SEG18 (23)	SEG 5 (67)	SEG 5 (10)	SEG 17 (55)	SEG17 (22)	SEG 4 (68)	SEG 4 ( 9)	SEG 16 (56)	SEG16 (21)	SEG 3 (69)	SEG 3 ( 8)	SEG 15 (57)	SEG15 (20)	SEG 2 (70)	SEG 2 ( 7)	SEG 14 (58)	SEG14 (19)	SEG 1 (71)	SEG 1 ( 6)	SEG 13 (59)	SEG13 (18)	SEG 0 (72)	SEG 0 ( 5)	SEG 12 (60)	SEG12 (17)		
LSI signal (Pin No.)	LCD (Pin No.)	LSI signal (Pin No.)	LCD (Pin No.)																																																								
SEG 24 (48)	SEG24 (29)	SEG 11 (61)	SEG11 (16)																																																								
SEG 23 (49)	SEG23 (28)	SEG 10 (62)	SEG10 (15)																																																								
SEG 22 (50)	SEG22 (27)	SEG 9 (63)	SEG 9 (14)																																																								
SEG 21 (51)	SEG21 (26)	SEG 8 (64)	SEG 8 (13)																																																								
SEG 20 (52)	SEG20 (25)	SEG 7 (65)	SEG 7 (12)																																																								
SEG 19 (53)	SEG19 (24)	SEG 6 (66)	SEG 6 (11)																																																								
SEG 18 (54)	SEG18 (23)	SEG 5 (67)	SEG 5 (10)																																																								
SEG 17 (55)	SEG17 (22)	SEG 4 (68)	SEG 4 ( 9)																																																								
SEG 16 (56)	SEG16 (21)	SEG 3 (69)	SEG 3 ( 8)																																																								
SEG 15 (57)	SEG15 (20)	SEG 2 (70)	SEG 2 ( 7)																																																								
SEG 14 (58)	SEG14 (19)	SEG 1 (71)	SEG 1 ( 6)																																																								
SEG 13 (59)	SEG13 (18)	SEG 0 (72)	SEG 0 ( 5)																																																								
SEG 12 (60)	SEG12 (17)																																																										
73/74	VCC/VREF	IN	Connected to GND.																																																								
75	AVSS	IN	Connected to VC.																																																								
76	COM3	OUT	<b>Common data signal.</b> Connected to LCD signal COM4.																																																								

Pin No.	Signal	I/O	Description
77	COM2	OUT	<b>Common data signal.</b> Connected to LCD signal COM3.
78	COM1	OUT	<b>Common data signal.</b> Connected to LCD signal COM2.
79	COM0	OUT	<b>Common data signal.</b> Connected to LCD signal COM1.
80	VL3	IN	<b>Power source voltage input terminal.</b> Standard voltage for LCD.

## ABSOLUTE HUMIDITY SENSOR CIRCUIT

### (1) Structure of Absolute Humidity Sensor

The absolute humidity sensor includes two thermistors as shown in the illustration. One thermistor is housed in the closed vessel filled with dry air while another in the open vessel. Each sensor is provided with the protective cover made of metal mesh to be protected from the external airflow.

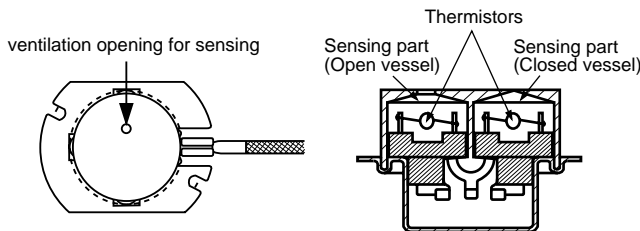

### (2) Operational Principle of Absolute Humidity Sensor

The figure below shows the basic structure of an absolute humidity sensor. A bridge circuit is formed by two thermistors and two resistors (R1 and R2).

The output of the bridge circuit is to be amplified by the operational amplifier.

Each thermistor is supplied with a current to keep it heated at about 150°C (302°F), the resultant heat is dissipated in the air and if the two thermistors are placed in different humidity conditions they show different degrees of heat conductivity leading to a potential difference between them causing an output voltage from the bridge circuit, the intensity of which is increased as the absolute humidity of the air increases. Since the output varies by minute, it is amplified by the operational amplifier.

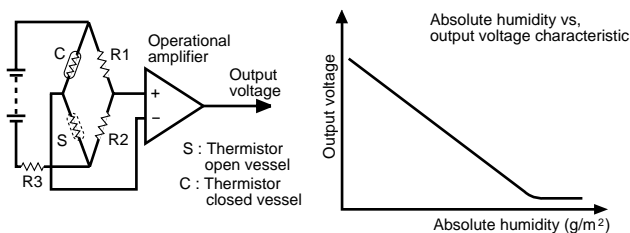

### (3) Detector Circuit of Absolute Humidity Sensor Circuit

This detector circuit is used to detect the output voltage of the absolute humidity circuit to allow the LSI to control sensor cooking of the unit. When the unit is set in the sensor cooking mode, 16 seconds clearing cycle occurs

then the detector circuit starts to function and the LSI observes the initial voltage available at its AN1 terminal. With this voltage given, the switches SW1 to SW5 in the LSI are turned on in such a way as to change the resistance values in parallel with R98 ~ R102 of IC2. Changing the resistance values results in that there is the same potential at both F-3 terminal of the absolute humidity sensor and AN0 terminal of the LSI. The voltage of AN1 terminal will indicate about -2.5V. This initial balancing is set up about 16 seconds after the unit is put in the Sensor Cooking mode. As the sensor cooking proceeds, the food is heated to generate moisture by which the resistance balance the bridge circuit is deviated to increase the voltage available at AN1 terminal of the LSI.

Then the LSI observes that voltage at AN1 terminal and compares it with its initial value, and when the comparison rate reaches the preset value (fixed for each menu to be cooked), the LSI causes the unit to stop sensor cooking; thereafter, the unit goes in the next operation automatically.

When the LSI starts to detect the initial voltage at AN1 terminal 16 seconds after the unit has been put in the Sensor Cooking mode, if it is not possible to balance, of the bridge circuit due to disconnection of the absolute humidity sensor, ERROR will appear on the display and the cooking is stopped.

### 1) Absolute humidity sensor circuit

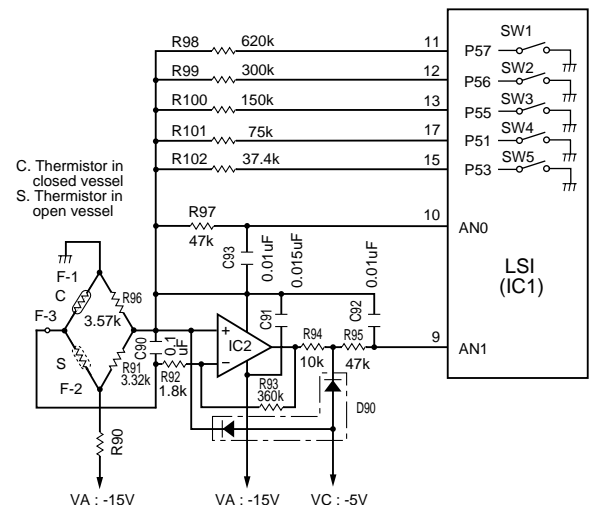

## SERVICING

### 1. Precautions for Handling Electronic Components

This unit uses CMOS LSI in the integral part of the circuits. When handling these parts, the following precautions should be strictly followed. CMOS LSI have extremely high impedance at its input and output terminals. For this reason, it is easily influenced by the surrounding high voltage power source, static electricity charge in clothes, etc. and sometimes it is not fully protected by the built-in protection circuit.

In order to protect CMOS LSI.

- 1) When storing and transporting, thoroughly wrap them in aluminium foil. Also wrap all PW boards containing them in aluminium foil.
- 2) When soldering, ground the technician as shown in the figure and use a grounded soldering iron and work table.

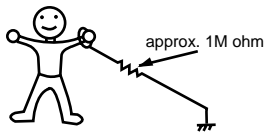

### 2. Shapes of Electronic Components

Transistor  
2SB1238

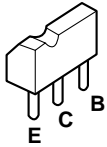

Transistor  
KRC243M

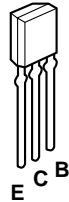

### 3. Servicing of Touch Control Panel

We describe the procedures to permit servicing of the touch control panel of the microwave oven and the precautions you must take when doing so. To perform the servicing, power to the touch control panel is available either from the power line of the oven itself or from an external power source.

#### (1) Servicing the touch control panel with power supply of the oven:

##### CAUTION:

**THE HIGH VOLTAGE TRANSFORMER OF THE MICROWAVE OVEN IS STILL LIVE DURING SERVICING AND PRESENTS A HAZARD.**

Therefore, before checking the performance of the touch control panel,

- 1) Disconnect the power supply cord, and then remove outer case.
- 2) Open the door and block it open.
- 3) Discharge high voltage capacitor.
- 4) Disconnect the leads to the primary of the power transformer.
- 5) Ensure that these leads remain isolated from other components and oven chassis by using insulation tape.
- 6) After that procedure, re-connect the power supply cord.

After checking the performance of the touch control panel,

- 1) Disconnect the power supply cord.
- 2) Open the door and block it open.
- 3) Re-connect the leads to the primary of the power transformer.
- 4) Re-install the outer case (cabinet).

- 5) Re-connect the power supply cord after the outer case is installed.

- 6) Run the oven and check all functions.

**A.** On some models, the power supply cord between the touch control panel and the oven itself is so short that the two can't be separated. For those models, check and repair all the controls (sensor-related ones included) of the touch control panel while keeping it connected to the oven.

**B.** On some models, the power supply cord between the touch control panel and the oven proper is long enough that they may be separated from each other. For those models, it is possible to check and repair the controls of the touch control panel while keeping it apart from the oven proper; in this case you must short both ends of the door sensing switch (on PWB) of the touch control panel with a jumper, which activates an operational state that is equivalent to the oven door being closed. As for the sensor-related controls of the touch control panel, checking them is possible if dummy resistor(s) with resistance equal to that of the controls are used.

#### (2) Servicing the touch control panel with power supply from an external power source:

Disconnect the touch control panel completely from the oven proper, and short both ends of the door sensing switch (on PWB) of the touch control panel, which activates an operational state that is equivalent to the oven door being closed. Connect an external power source to the power input terminal of the touch control panel, then it is possible to check and repair the controls of the touch control panel it is also possible to check the sensor-related controls of the touch control panel by using the dummy resistor(s).

### 4. Servicing Tools

Tools required to service the touch control panel assembly.

- 1) Soldering iron: 30W  
(It is recommended to use a soldering iron with a grounding terminal.)
- 2) Oscilloscope: Single beam, frequency range: DC-10MHz type or more advanced model.
- 3) Others: Hand tools

### 5. Other Precautions

- 1) Before turning on the power source of the control unit, remove the aluminium foil applied for preventing static electricity.
- 2) Connect the connectors of the key unit to the control unit being sure that the lead wires are not twisted.
- 3) After aluminium foil is removed, be careful that abnormal voltage due to static electricity etc. is not applied to the input or output terminals.
- 4) Attach connectors, electrolytic capacitors, etc. to PWB, making sure that all connections are tight.
- 5) Be sure to use specified components where high precision is required.

## COMPONENT REPLACEMENT AND ADJUSTMENT PROCEDURE

### WARNING AGAINST HIGH VOLTAGE:

Microwave ovens contain circuitry capable of producing very high voltage and current, contact with following parts may result in severe, possibly fatal, electric shock.

(Example)

High Voltage Capacitor, Power Transformer, Magnetron, High Voltage Rectifier Assembly, High Voltage Harness etc..

**WARNING:** Avoid possible exposure to microwave energy. Please follow the instructions below before operating the oven.

- |  |  |
|--|--|
| <ol style="list-style-type: none"> <li>1. Disconnect the power supply cord.</li> <li>2. Make sure that a definite "click" can be heard when the microwave oven door is unlatched. (Hold the door in a closed position with one hand, then push the door open button with the other, this causes the latch leads to rise, it is then possible to hear a "click" as the door switches operate.)</li> <li>3. Visually check the door and cavity face plate for damage (dents, cracks, signs of arcing etc.).</li> </ol> | <ol style="list-style-type: none"> <li>1. Door does not close firmly.</li> <li>2. Door hinge, support or latch hook is damaged.</li> <li>3. The door gasket or seal is damaged.</li> <li>4. The door is bent or warped.</li> <li>5. There are defective parts in the door interlock system.</li> <li>6. There are defective parts in the microwave generating and transmission assembly.</li> <li>7. There is visible damage to the oven.</li> </ol> |
|--|--|

Carry out any remedial work that is necessary before operating the oven.

Do not operate the oven if any of the following conditions exist;

Do not operate the oven:

1. Without the RF gasket (Magnetron).
2. If the wave guide or oven cavity are not intact.
3. If the door is not closed.
4. If the outer case (cabinet) is not fitted.

### WARNING FOR WIRING

**To prevent an electric shock, take the following precautions.**

- |  |  |
|--|--|
| <ol style="list-style-type: none"> <li>1. Before wiring,             <ol style="list-style-type: none"> <li>1) Disconnect the power supply cord.</li> <li>2) Open the door block it open.</li> <li>3) Discharge the high voltage capacitor and wait for 60 seconds.</li> </ol> </li> <li>2. Don't let the wire leads touch to the following parts;             <ol style="list-style-type: none"> <li>1) High voltage parts:<br/>Magnetron, High voltage transformer, High voltage capacitor and High voltage rectifier assembly.</li> <li>2) Hot parts:<br/>Oven lamp, Magnetron, Power transformer and Oven cavity.</li> </ol> </li> </ol> | <ol style="list-style-type: none"> <li>3) Sharp edge:<br/>Bottom plate, Oven cavity, Waveguide flange, Chassis support and other metallic plate.</li> <li>4) Movable parts (to prevent a fault)<br/>Fan blade, Fan motor, Switch, Open lever, Open button.</li> <li>3. Do not catch the wire leads in the outer case cabinet.</li> <li>4. Insert the positive lock connector until its pin is locked and make sure that the wire leads do not come off even if the wire leads are pulled.</li> <li>5. To prevent an error function, connect the wire leads correctly, referring to the Pictorial Diagram.</li> </ol> |
|--|--|

### THE FOLLOWING ADJUSTMENTS OR COMPONENT REPLACEMENT CAN BE PERFORMED WITHOUT REMOVING THE OVEN FROM THE WALL

- |  |  |
|--|--|
| <ol style="list-style-type: none"> <li>1. Hood lamps, hood lamp sockets, oven lamp, grease filter and charcoal filter.</li> <li>2. Base cover and hood lamp glass assembly.</li> </ol> | <ol style="list-style-type: none"> <li>3. Turntable motor.</li> <li>4. Hood exhaust louver.</li> <li>5. Control panel assembly or components.</li> </ol> |
|--|--|

### AH SENSOR REMOVAL

- |  |  |
|--|--|
| <ol style="list-style-type: none"> <li>1. Disconnect the power supply cord, remove the oven from wall, and remove outer case. (Refer to procedure of "REMOVAL OF OVEN FROM WALL" AND "OUTER CASE REMOVAL".) And proceed as follows.</li> </ol> | <ol style="list-style-type: none"> <li>2. Open the door and block it open.</li> <li>3. To discharge the high voltage capacitor, wait for 60 seconds.</li> <li>4. Remove three (3) screws holding the hood intake duct R</li> </ol> |
|--|--|

to the oven cavity top plate, the oven cavity front flange and the fan duct. And remove the hood intake duct R.

5. Disconnect the connector CN-F of AH sensor from the control unit.
6. Remove the two (2) screws and one (1) washer holding the AH sensor to the hood duct L.
7. Release the wire lead of AH sensor from the holes of the hood ducts L and R.
8. Now, the AH sensor is free.

**NOTE:** When the AH sensor is reinstalled, the wire tie of the AH sensor should be positioned under the hole of the oven cavity top plate (right).

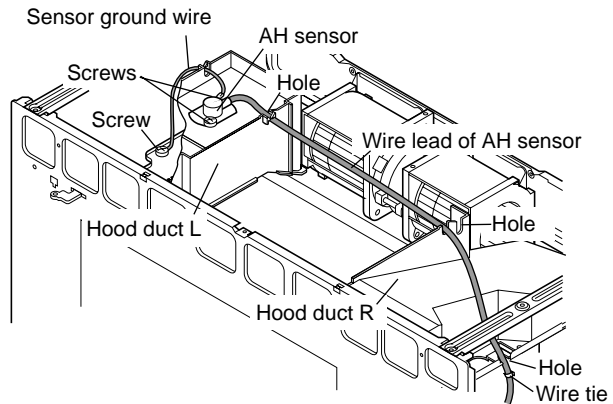

This illustration is under the condition which hood intake duct R is removed

## CONTROL PANEL ASSEMBLY, CONTROL UNIT AND KEY UNIT REMOVAL

1. Disconnect the power supply cord.
2. Open the door and block it open.
3. To discharge the high voltage capacitor, wait for 60 seconds.
4. Remove three (3) screws holding the hood exhaust louver to oven cavity front face plate.
5. Remove the hood exhaust louver from the oven by pushing the right and left tabs of the hood exhaust louver. (Refer to procedure of "HOOD EXHAUST LOUVER REMOVAL")
6. Remove one (1) screw holding the control panel to the oven cavity front face plate.
7. Release the control panel from the oven cavity front face plate by lifting it up.
8. Disconnect the wire leads from the relays RY1 and RY2.
9. Disconnect the connectors CN-A, CN-B, CN-E and CN-F from the control unit.
10. Remove the control panel assembly from the oven.
11. Now, the control panel assembly is free.
12. Disconnect the connector CN-G from the control unit.
13. Remove the two (2) screws holding the LCD holder to the key fixing plate.
14. Remove two (2) screws holding the power unit to the key fixing plate.
15. Release the two (2) tabs holding the power unit to the key fixing plate.
16. Release the three (3) tabs holding the LCD to the LCD holder.
17. Release the two (2) tabs holding the LSI unit to the LCD holder.
18. Remove the LCD holder and the LED sheet.
19. Now, the control unit is free.

20. Remove the one (1) screw holding the key fixing plate to the control panel.
21. Release the six (6) tabs holding the key fixing plate to the control panel.
22. Remove the key fixing plate from the control panel.
23. Remove the key unit from the key fixing plate.
24. Now, the key unit is free

### NOTES FOR KEY UNIT REPLACEMENT

1. Do not reuse the torn key unit because the performance of the adhesive becomes weak.
2. Before attaching a new key unit, wipe off remaining adhesive on the key fixing plate surfaces completely with a soft cloth soaked in alcohol.
3. When attaching the key unit to the key fixing plate, adjust the upper edge and right edge of the key unit to the correct position of key fixing plate. See key unit location.
4. Stick the key unit firmly to the key fixing plate by rubbing with soft cloth not to scratch.

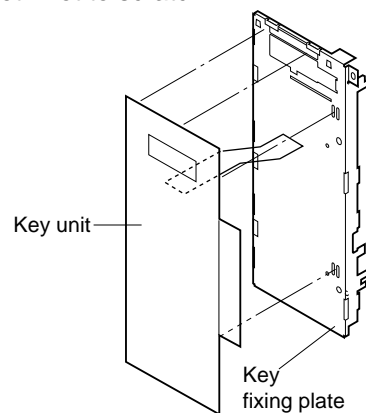

**Key unit location**

## OVEN LAMP REMOVAL

1. Disconnect the power supply cord.
2. Open the door and block it open.
3. To discharge the high voltage capacitor, wait for 60 seconds.

4. Remove the hood exhaust louver and release the control panel assembly, referring to items 4 to 7 of "CONTROL PANEL ASSEMBLY, CONTROL UNIT AND KEY UNIT REMOVAL".

5. Disconnect only the connector CN-F from the control unit. It is not necessary to disconnect other connectors or wire leads from the control unit.
6. Release the oven lamp socket from the magnetron duct by turning the socket counterclockwise.
7. Remove the oven lamp from the socket by turning the oven lamp.
8. Now the oven lamp is free.

## OVEN LAMP SOCKET REMOVAL

1. Disconnect the power supply cord.
2. Open the door and block it open.
3. Remove three (3) screws holding the hood exhaust louver to oven cavity front face plate.
4. Remove the hood exhaust louver from the oven by pushing the right and left tabs of the hood exhaust louver.
5. Remove the hood exhaust louver from the oven by pushing the right and left tabs of the hood exhaust louver. (Refer to procedure of "HOOD EXHAUST LOUVER REMOVAL")
6. Remove one (1) screw holding the control panel to the oven cavity front face plate.
7. Release the control panel from the oven cavity front face plate by lifting it up and tilting top edge back.
8. Turn the lamp socket and release it from the magnetron duct.
9. Now, the oven lamp is free.
10. Pull the wire leads from the oven lamp socket by pushing the terminal hole of the oven lamp socket with the small flat type screw driver.
11. Now, the oven lamp socket is free.

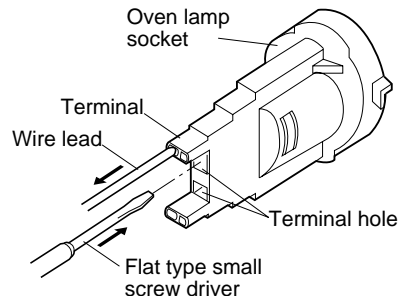

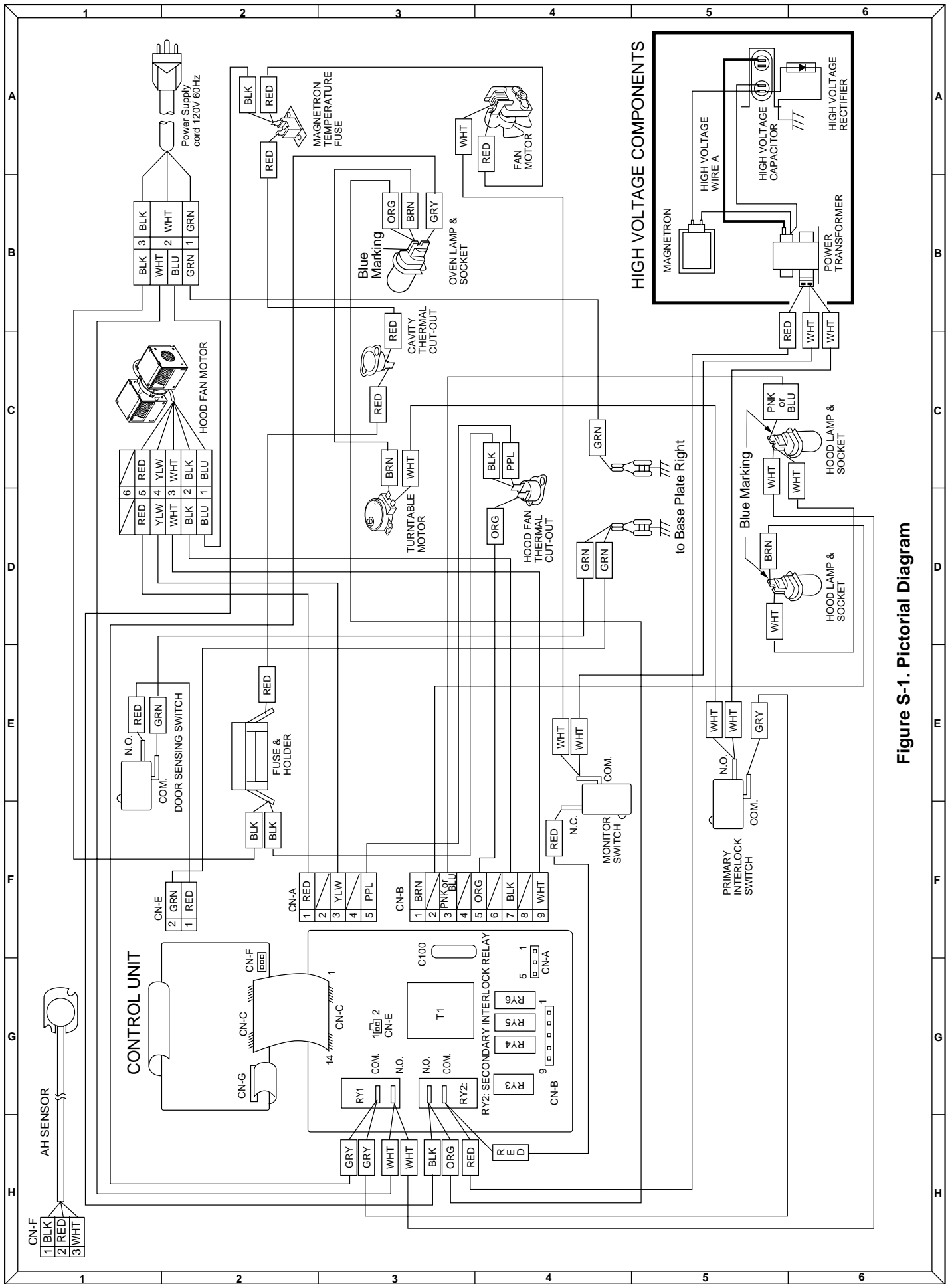

Figure S-1. Pictorial Diagram

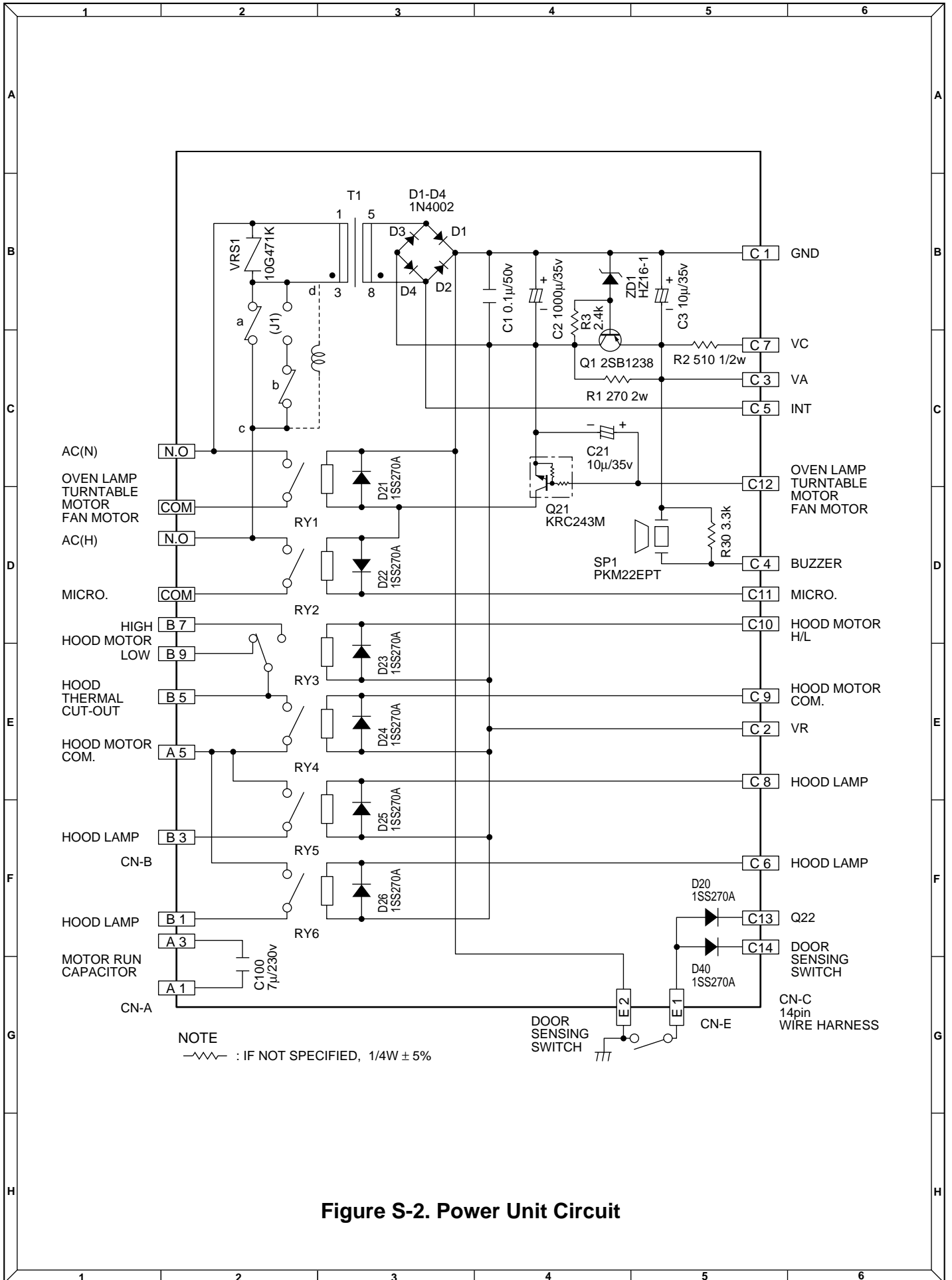

Figure S-2. Power Unit Circuit

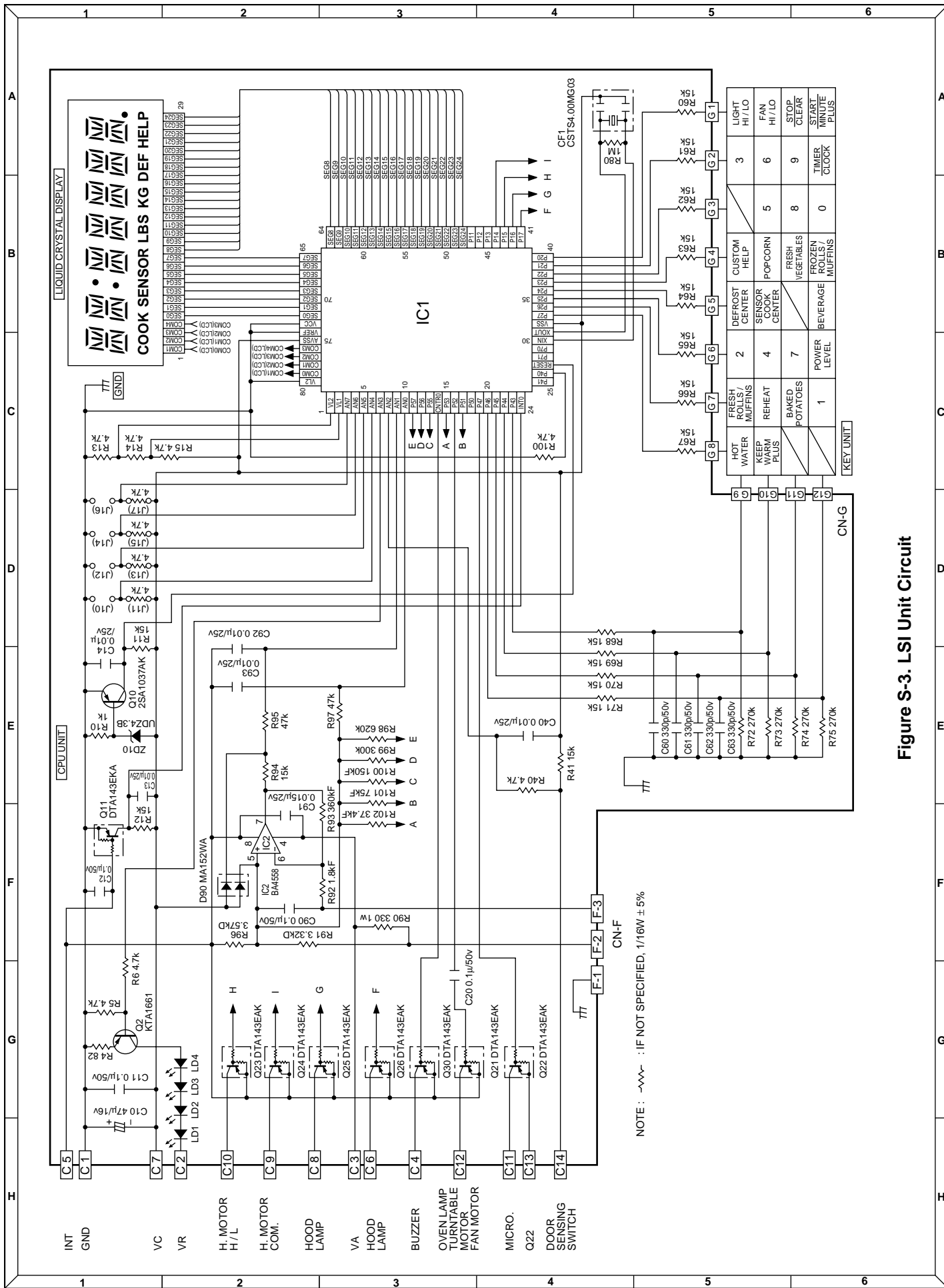

Figure S-3. LSI Unit Circuit

NOTE: ~~~~ : IF NOT SPECIFIED, 1/16W ± 5%



## PARTS LIST

Note: The parts marked "Δ" may cause undue microwave exposure.

The parts marked "\*" are used in voltage more than 250V.

"δ" MARK: PARTS DELIVERY SECTION

REF. NO.	PART NO.	δ	DESCRIPTION	Q'TY	CODE
<b>ELECTRIC PARTS</b>					
* 1- 1	FH-DZB016MRY0	M	High voltage rectifier assembly	1	AH
* 1- 2	RC-QZA234WRE0	M	High voltage capacitor	1	AP
1- 3	QFS-TA013WRE0	M	Temperature fuse 150°C (Magnetron)	1	AE
1- 4	RMOTDA211WRE0	M	Turntable motor	1	AL
1- 5	RTHM-A070WRE0	M	Thermal cut-out 145°C (Cavity)	1	AF
1- 6	RTHM-0044MRE0	M	Thermal cut-out N.O. 60°C (Hood Fan)	1	AH
* 1- 7	RTRN-B068MRE0	M	Power transformer	1	BC
* 1- 8	RV-MZA288WRE0	M	Magnetron	1	BK
1- 9	QFSHDB003MRE0	M	Fuse holder	1	AD
1-10	QSW-MA085WRE0	M	Primary interlock and door sensing switches	2	AE
1-11	FFS-BA016/KIT	M	Monitor switch (V-16G-2C25) with fuse (20A) assembly	1	AF
1-12	FACCDB011MRE0	M	Power supply cord	1	AQ
1-13	QSOCLB006MRE0	M	Oven lamp socket and hood lamp sockets	3	AE
1-14	FMOTEA441WRKZ	M	Hood fan motor	1	BC
1-15	RMOTEB031MRE0	M	Fan motor	1	AR
1-16	RLMPTA068WRE0	M	Oven lamp and hood lamps	3	AE
1-17	FDTCTA201WRK0	M	AH sensor	1	AR

### CABINET PARTS

2- 1	LSTY-B024MRP0	M	Rear stay	1	AE
2- 2	FDIF-B014MRK0	M	Hood exhaust louver	1	AX
2- 3	GDAI-B065MRP0A	M	Base plate R	1	AG
2- 4	FDECAB031MRK0	M	Front panel L	1	AT
2- 5	GCABUB103MRP0	M	Outer case cabinet	1	AZ
2- 6	TMAPCB067MRRO	M	Schematic diagram	1	AB
2- 7	FANGKB009MRY0	M	Hood lamp glass assembly	1	AN
2-7-1	LANGQB016MRP0	M	Hood lamp glass angle	1	AG
2-7-2	PGLSPB004MRE0	M	Hood lamp glass	1	AH
2- 8	PCOVBP096MRT0	M	Base cover	1	AV

### CONTROL PANEL PARTS

3- 1	CPWBFB064MRU0	M	Control unit	1	BF
3- 1A	QCNCMA017JDZZ	M	3-pin connector CN-A	1	AG
3- 1B	QCNCMA448DRE0	M	5-pin connector CN-B	1	AF
3- 1C	QCNCMA275DRE0	J	2-pin connector CN-E	1	AB
3- 1D	FW-VZB189MRE0	M	Lead wire harness CN-C	1	AB
C1	RC-KZA087DRE0	J	Capacitor 0.1 uF 50V	1	AB
C2	VCEAB31VW108M	J	Capacitor 1000 uF 35V	1	AF
C3	VCEAB31VW106M	J	Capacitor 10 uF 35V	1	AB
C21	VCEAB31VW106M	J	Capacitor 10 uF 35V	1	AB
C100	RC-QZB014MRE0	M	Capacitor 7 uF 230V	1	AD
D1-4	RH-DZA006PRE0	J	Diode (1N4002)	4	AD
D20-26	VHD1SS270A/-1	J	Diode (1SS270A)	7	AA
D40	VHD1SS270A/-1	J	Diode (1SS270A)	1	AA
Q1	VS2SB1238// -3	J	Transistor (2SB1238)	1	AA
Q21	VSKRC243M// -3	J	Transistor (KRC243M)	1	AB
R1	VRS-B13AA331J	J	Resistor 330 ohm 1W	1	AA
R2	VRD-B12HF511J	J	Resistor 510 ohm 1/2W	1	AB
R3	VRD-B12EF242J	J	Resistor 2.4k ohm 1/4W	1	AA
R30	VRD-B12EF332J	J	Resistor 3.3k ohm 1/4W	1	AA
RY1-2	RRLY-A113DRE0	M	Relay (DU24D1-1PR(M))	2	AG
RY3	RRLY-A123DRZZ	M	Relay (G5S-1 24V)	1	AG
RY4-6	RRLY-B004MRE0	M	Relay (FTR-F3AA024E)	3	AG
SP1	RALM-A014DRE0	J	Buzzer (PKM22EPT)	1	AG
T1	RTRNPB017MRE0	M	Transformer	1	AS
VRS1	RH-VZA032DRE0	J	Varistor (10G471K)	1	AE
ZD1	VHEHZ161/// -1	J	Zener diode (HZ16-1)	1	AA
3- 2	FPNLCB420MRK0	M	Control panel sub. assembly	1	BB
3- 2-1	FUNTKB332MRE0	M	Key unit	1	AU

REF. NO.	PART NO.	δ	DESCRIPTION	Q'TY	CODE
3- 2-2	FDECAB030MRK0	M	Open button	1	AU
3- 2-3	JBTN-B138MRF0	M	Select button	1	AD
3- 2-4	MSPRTA050WRE0	M	Button spring	1	AA
3- 2-5	PSHEPB101MRE0	M	Button rubber	1	AC
3- 2-6	PCAP-B007MR10	M	Button cap	1	AC
3- 3	LHLD-B018MRF0	M	LCD holder	1	AC
3- 4	PSHEPB023MRE0	M	LED sheet	1	AR
3- 5	XEPSD30P10XS0	M	Screw; 3mm x 10mm	5	AB

## OVEN PARTS

4- 1	LSTPPB038MRF0	M	Door stopper	1	AB
4- 2	FROLPB025MRK0	M	Turntable support assembly	1	AN
4- 3	NTNT-A108WREZ	M	Turntable tray	1	AM
4- 4	LBNDKB009MRP0	M	Capacitor holder	1	AB
4- 5	PDUC-B111MRF0	M	Magnetron duct	1	AF
4- 6	MLEVPB016MRF0	M	Open lever	1	AD
4- 7	*****	M	Oven cavity (Not replaceable part)	1	--
4- 8	PPACGB014MRF0	M	Turntable motor packing	1	AA
4- 9	PHOK-B018MRF0	M	Latch hook	1	AF
4-10	FANGTB005MRY0	M	Unit mounting plate assembly	1	AS
4-11	NFANPB006MRE0	M	Fan blade	1	AC
4-12	LBSHC0037WRE0	M	Cord bushing	1	AB
4-13	MLEVFB007MRP0	M	Mounting lever	2	AC
4-14	PDUC-B112MRP0	M	Hood intake duct R	1	AG
4-15	PCOVBP085MRP0	M	Waveguide cover	1	AH
4-16	MSPRTA046WRE0	M	Latch spring	2	AB
4-17	LANGTB055MRP0	M	Chassis support	2	AD
4-18	PDUC-B115MRF0	M	Hood duct R	1	AQ
4-19	PDUC-B114MRF0	M	Hood duct L	1	AQ
4-20	PDUC-B113MRP0	M	Fan duct	1	AH
4-21	PDUC-B117MRF0	M	Orifice	1	AC
4-22	PCUSGB043MRP0	M	Transformer cushion	1	AC
4-23	PCUSUB045MRP0	M	Cushion	1	AC
4-24	PCUSUB019MRP0	M	Cushion	1	AC
4-25	PCUSUB061MRP0	M	Cushion	1	AC

## DOOR PARTS

5	CDORFB317MRK0	M	Door assembly	1	BH
5- 1	FDORFB070MRT0	M	Door panel assembly	1	AW
5- 2	FCOV-B221MRK0	M	Door frame assembly	1	BE
5-2-1	LSTPPB023MRF0	M	Latch head	1	AC
5-2-2	MSPRTA046WRE0	M	Latch spring	1	AB
5-2-3	LSTPPB037MRF0	M	Glass stopper	2	AC
5- 3	GCOVHB044MRF0	M	Choke cover	1	AG
5- 4	PSHEPB021MRE0	M	Sealer film	1	AE
5- 5	XCPSD40P08000	M	Screw : 4mm x 8mm	4	AA

## MISCELLANEOUS

6- 1	CFZK-B460MRK0	M	Installation material assembly	1	AH
6-1-1	LBSHC0040MRE0	M	Grommet	1	AC
6-1-2	LX-BZ0195WRE0	M	Toggle screw	4	AC
6-1-3	LX-MZB001MRE0	M	Cord holder	1	AB
6-1-4	XBRSD50P60000	M	Screw : 5mm x 60mm	2	AA
6-1-5	XOTSD40P12000	M	Screw : 4mm x 12mm	3	AA
6-1-6	XTSSD50P35000	M	Screw : 5mm x 35mm	6	AA
6-1-7	XWHSD50-16300	M	Washer	2	AA
6- 2	TINSEB316MRK0	M	Operation manual	1	AF
6- 3	TINSKB081MRR0	M	Top/wall template	1	AD
6- 4	QW-QZB025MRE0	M	High voltage wire A	1	AT
6- 5	FW-VZB187MRE0	M	Main harness	1	AT
6- 6	TCAUAB041MRR0	M	DHHS service caution label	2	AA
6- 7	TCAUAB045MRR0	M	Monitor caution label	1	AA
6- 8	TCAUAB005MRR0	M	Revised DHHS/GRD C/label	1	AB
6- 9	FW-VZB188MRE0	M	Low voltage harness	1	AT
6-10	PFIL-B006MRE0	M	Charcoal filter	1	AE
6-11	PFIL-B002MRE0	M	Grease filter	2	AF
6-12	FFTA-B005MRK0	M	Exhaust damper assembly	1	AH
6-13	PCUSUB059MRP0	M	Cushion (only for horizontal venting)	1	AC

REF. NO.	PART NO.	□	DESCRIPTION	Q'TY	CODE
6-14	QW-VZB011MRE0	M	Sensor ground wire	1	AB
6-15	LANG-B002MRP0	M	Scale plate	2	AD

### SCREWS,NUTS AND WASHERS

7- 1	LX-CZB004MRE0	M	Special screw	3	AA
7- 2	XOTSF40P12000	M	Screw : 4mm x 12mm	5	AA
7- 3	XOTSD40P12000	M	Screw : 4mm x 12mm	26	AA
7- 4	XHTSD40P08RV0	M	Screw : 4mm x 8mm	2	AA
7- 5	LX-CZA038WRE0	M	Special screw	9	AA
7- 6	LX-CZ0052WRE0	M	Special screw	2	AA
7- 7	LX-WZB003MRE0	M	Sensor washer	1	AA
7- 8	XCBSD30P08000	M	Screw : 3mm x 8mm	5	AA
7- 9	LX-BZA041WRE0	M	Special screw	5	AA

### HOW TO ORDER REPLACEMENT PARTS

To have your order filled promptly and correctly, please furnish the following information.

1. MODEL NUMBER
2. REF. NO.
3. PART NO.
4. DESCRIPTION

Order Parts from the authorized SHARP parts Distributor for your area.

Defective parts requiring return should be returned as indicated in the Service Policy.

### PACKING AND ACCESSORIES

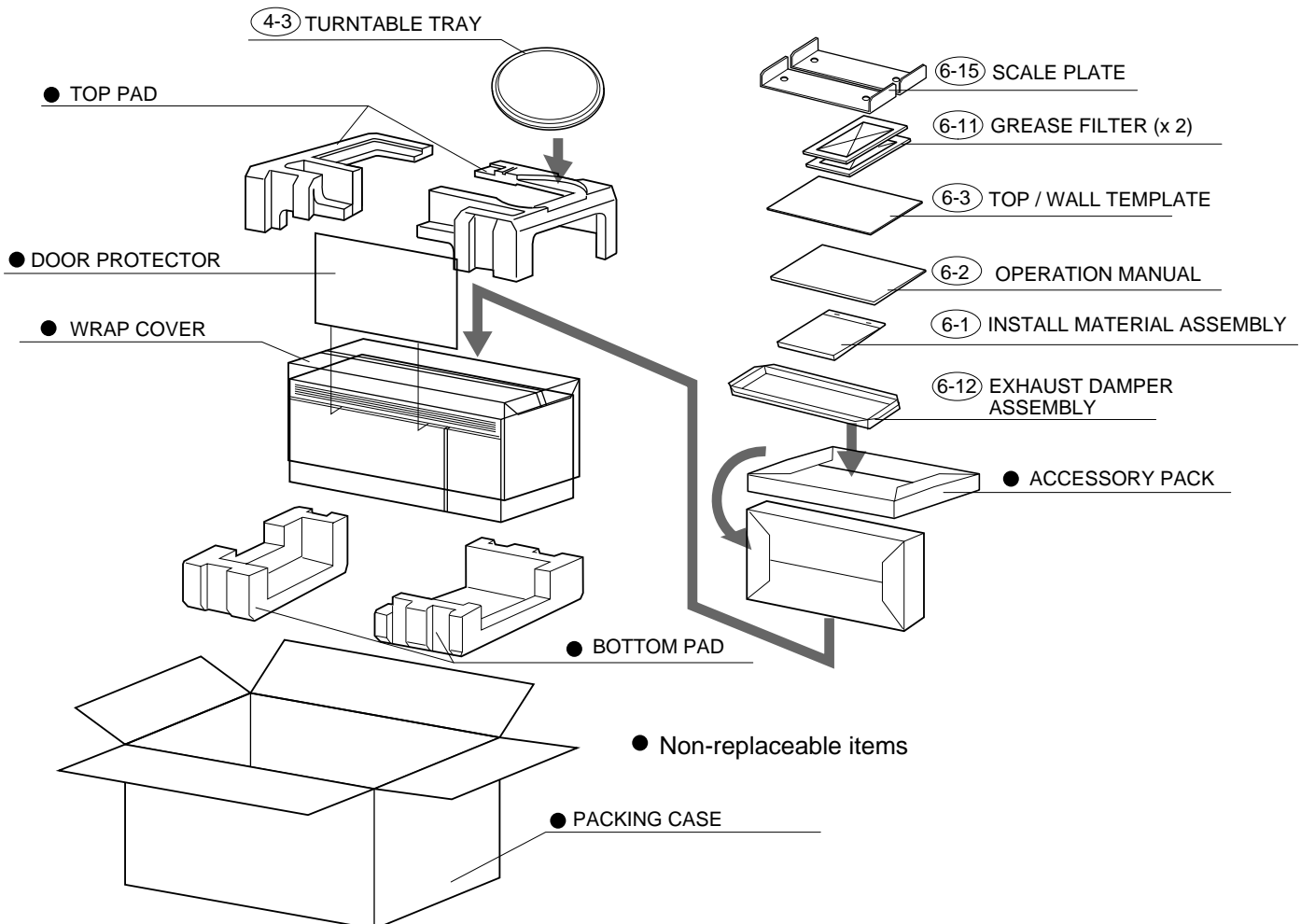

# OVEN AND CABINET PARTS

