

SHARP SERVICE MANUAL

S4808R1490X//

OVER THE RANGE MICROWAVE OVEN

MODELS **R-1490**
R-1491
R-1492

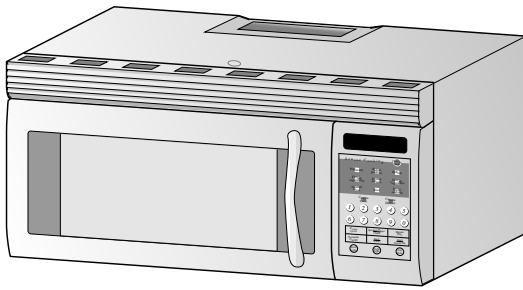

In the interest of user-safety the oven should be restored to its original condition and only parts identical to those specified should be used.

WARNING TO SERVICE PERSONNEL: Microwave ovens contain circuitry capable of producing very high voltage and current, contact with following parts may result in a severe, possibly fatal, electrical shock. (High Voltage Capacitor, High Voltage Power Transformer, Magnetron, High Voltage Rectifier Assembly, High Voltage Harness etc..)

This is a supplemental Service Manual for Models R-1490, R-1491 and R-1492. These models are quite similar to base model R-1480, R-1481 and R-1482. Use this supplemental manual together with the Base Models Service Manual (Refer No. is S3807R1480X//) for complete operation, service information, etc..

TABLE OF CONTENTS

	Page
PRECAUTIONS TO BE OBSERVED BEFORE AND DURING SERVICING TO AVOID POSSIBLE EXPOSURE TO EXCESSIVE MICROWAVE ENERGY	INSIDE FRONT COVER
BEFORE SERVICING	INSIDE FRONT COVER
WARNING TO SERVICE PERSONNEL	1
MICROWAVE MEASUREMENT PROCEDURE	2
FOREWORD AND WARNING	3
PRODUCT SPECIFICATIONS	4
GENERAL INFORMATION	4
OPERATION	6
TROUBLESHOOTING GUIDE	8
TEST PROCEDURE	9
TOUCH CONTROL PANEL ASSEMBLY	11
COMPONENT REPLACEMENT AND ADJUSTMENT PROCEDURE	13
PICTORIAL DIAGRAM	15
CONTROL PANEL CIRCUIT	16
PARTS LIST	17
PACKING AND ACCESSORIES	22

SHARP CORPORATION

This document has been published to be used for after sales service only.

The contents are subject to change without notice.

PRECAUTIONS TO BE OBSERVED BEFORE AND DURING SERVICING TO AVOID POSSIBLE EXPOSURE TO EXCESSIVE MICROWAVE ENERGY

- (a) Do not operate or allow the oven to be operated with the door open.
- (b) Make the following safety checks on all ovens to be serviced before activating the magnetron or other microwave source, and make repairs as necessary: (1) interlock operation, (2) proper door closing, (3) seal and sealing surfaces (arcing, wear, and other damage), (4) damage to or loosening of hinges and latches, (5) evidence of dropping or abuse.
- (c) Before turning on microwave power for any service test or inspection within the microwave generating compartments, check the magnetron, wave guide or transmission line, and cavity for proper alignment, integrity, and connections.
- (d) Any defective or misadjusted components in the interlock, monitor, door seal, and microwave generation and transmission systems shall be repaired, replaced, or adjusted by procedures described in this manual before the oven is released to the owner.
- (e) A microwave leakage check to verify compliance with the Federal Performance Standard should be performed on each oven prior to releasing oven to the owner.

BEFORE SERVICING

Before servicing an operative unit, perform a microwave emission check as per the Microwave Measurement Procedure outlined in this service manual.

If microwave emissions level is in excess of the specified limit, contact SHARP ELECTRONICS CORPORATION immediately @1-800-237-4277.

If the unit operates with the door open, service person should 1) tell the user not to operate the oven and 2) contact SHARP ELECTRONICS CORPORATION and Food and Drug Administration's Center for Devices and Radiological Health immediately.

Service personnel should inform SHARP ELECTRONICS CORPORATION of any certified unit found with emissions in excess of $4\text{mW}/\text{cm}^2$. The owner of the unit should be instructed not to use the unit until the oven has been brought into compliance.

WARNING TO SERVICE PERSONNEL

Microwave ovens contain circuitry capable of producing very high voltage and current, contact with following parts may result in a severe, possibly fatal, electrical shock.

(Example)

High Voltage Capacitor, High Voltage Power Transformer, Magnetron, High Voltage Rectifier Assembly, High Voltage Harness etc..

Read the Service Manual carefully and follow all instructions.

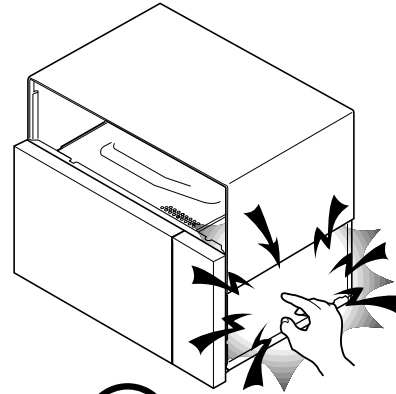

**Don't Touch !
Danger High Voltage**

Before Servicing



1. Disconnect the power supply cord , and then remove outer case.
2. Open the door and block it open.
3. Discharge high voltage capacitor.

WARNING: RISK OF ELECTRIC SHOCK. DISCHARGE THE HIGH-VOLTAGE CAPACITOR BEFORE SERVICING.

The high-voltage capacitor remains charged about 60 seconds after the oven has been switched off. Wait for 60 seconds and then short-circuit the connection of the high-voltage capacitor (that is the connecting lead of the high-voltage rectifier) against the chassis with the use of an insulated screwdriver.

Whenever troubleshooting is performed the power supply must be disconnected. It may in, some cases, be necessary to connect the power supply after the outer case has been removed, in this event,

1. Disconnect the power supply cord, and then remove outer case.
2. Open the door and block it open.
3. Discharge high voltage capacitor.
4. Disconnect the leads to the primary of the power transformer.
5. Ensure that these leads remain isolated from other components and oven chassis by using insulation tape.
6. After that procedure, reconnect the power supply cord.

When the testing is completed,

1. Disconnect the power supply cord, and then remove outer case.
2. Open the door and block it open.
3. Discharge high voltage capacitor.
4. Reconnect the leads to the primary of the power transformer.
5. Reinstall the outer case (cabinet).
6. Reconnect the power supply cord after the outer case is installed.
7. Run the oven and check all functions.

After repairing

1. Reconnect all leads removed from components during testing.
2. Reinstall the outer case (cabinet).
3. Reconnect the power supply cord after the outer case is installed.
4. Run the oven and check all functions.

Microwave ovens should not be run empty. To test for the presence of microwave energy within a cavity, place a cup of cold water on the oven turntable, close the door and set the power to HIGH and set the microwave timer for two (2) minutes. When the two minutes has elapsed (timer at zero) carefully check that the water is now hot. If the water remains cold carry out **Before Servicing** procedure and re-examine the connections to the component being tested.

When all service work is completed and the oven is fully assembled, the microwave power output should be checked and microwave leakage test should be carried out.

MICROWAVE MEASUREMENT PROCEDURE

A. Requirements:

- 1) Microwave leakage limit (Power density limit): The power density of microwave radiation emitted by a microwave oven should not exceed 1 mW/cm^2 at any point 5cm or more from the external surface of the oven, measured prior to acquisition by a purchaser, and thereafter (through the useful life of the oven), 5 mW/cm^2 at any point 5cm or more from the external surface of the oven.
- 2) Safety interlock switches Primary interlock relay and door sensing switch shall prevent microwave radiation emission in excess of the requirement as above mentioned, secondary interlock switch shall prevent microwave radiation emission in excess of 5 mW/cm^2 at any point 5cm or more from the external surface of the oven.

B. Preparation for testing:

Before beginning the actual measurement of leakage, proceed as follows:

- 1) Make sure that the actual instrument is operating normally as specified in its instruction booklet.

Important:

Survey instruments that comply with the requirement for instrumentation as prescribed by the performance standard for microwave ovens, 21 CFR 1030.10(c)(3)(i), must be used for testing.

- 2) Place the oven tray in the oven cavity.
- 3) Place the load of $275 \pm 15 \text{ ml}$ (9.8 oz) of tap water initially at $20 \pm 5^\circ \text{C}$ (68°F) in the center of the oven cavity. The water container shall be a low form of 600 ml (20 oz) beaker with an inside diameter of approx. 8.5 cm (3-1/2 in.) and made of an electrically nonconductive material such as glass or plastic. The placing of this standard load in the oven is important not only to protect the oven, but also to insure that any leakage is measured accurately.
- 4) Set the cooking control on Full Power Cooking Mode
- 5) Close the door and select a cook cycle of several minutes. If the water begins to boil before the survey is completed, replace it with 275 ml of cool water.

C. Leakage test:

Closed-door leakage test (microwave measurement)

- 1) Grasp the probe of the survey instrument and hold it perpendicular to the gap between the door and the body of the oven.
- 2) Move the probe slowly, not faster than 1 in./sec. (2.5 cm/sec.) along the gap, watching for the maximum indication on the meter.
- 3) Check for leakage at the door screen, sheet metal seams and other accessible positions where the continuity of the metal has been breached (eg., around the switches, indicator, and vents). While testing for leakage around the door pull the door away from the front of the oven as far as is permitted by the closed latch assembly.
- 4) Measure carefully at the point of highest leakage and make sure that the highest leakage is no greater than 4 mW/cm^2 , and that the secondary interlock switch does turn the oven OFF before any door movement.

NOTE: After servicing, record data on service invoice and microwave leakage report.

SERVICE MANUAL

SHARP

OVER THE RANGE MICROWAVE OVEN

R-1490/ R-1491/1492

FOREWORD

This Manual has been prepared to provide Sharp Electronics Corp. Service Personnel with Operation and Service Information for the SHARP OVER THE RANGE MICROWAVE OVEN, R-1490/ R-1491/ R1492.

The models R-1490, R-1491 and R-1492 is quite similar to base models R-1480/81/82 (Refer No. is S3807R1480X//).

It is recommended that service personnel carefully study the entire text of this manual and base model service manual so that they will be qualified to render satisfactory customer service.

Check the interlock switches and the door seal carefully. Special attention should be given to avoid electrical shock and microwave radiation hazard.

WARNING

Never operate the oven until the following points are ensured.

- (A) The door is tightly closed.
- (B) The door brackets and hinges are not defective.
- (C) The door packing is not damaged.
- (D) The door is not deformed or warped.
- (E) There is not any other visible damage with the oven.

Servicing and repair work must be carried out only by trained service personnel.

DANGER

Certain initial parts are intentionally not grounded and present a risk of electrical shock only during servicing. Service personnel - Do not contact the following parts while the appliance is energized; High Voltage Capacitor, Power Transformer, Magnetron, High Voltage Rectifier Assembly, High Voltage Harness; If provided, Vent Hood, Fan assembly, Cooling Fan Motor.

All the parts marked “**” on parts list are used at voltages more than 250V.

Removal of the outer wrap gives access to voltage above 250V.

All the parts marked “Δ” on parts list may cause undue microwave exposure, by themselves, or when they are damaged, loosened or removed.

SHARP ELECTRONICS CORPORATION

SHARP PLAZA, MAHWAH,
NEW JERSEY 07430-2135

PRODUCT SPECIFICATION

ITEM	DESCRIPTION
Power Requirements	120 Volts / 14.3 Amperes 60 Hertz Single phase, 3 wire grounded
Power Output	950 watts (IEC-705 TEST PROCEDURE) Operating frequency of 2450MHz
Convection Power Output	1700 watts
Case Dimensions	Width 29-15/16" Height 16-3/8" Depth 15- 1/4" (Not including the door handle)
Cooking Cavity Dimensions	Width 20-1/4" Height 8-3/16" Depth 14-1/2"
1.4 Cubic Feet	
Hood lamp	2 bulbs, 30W x 2, Incandescent light bulbs
Hood fan	Approx. 300 C.F.M.
Control Complement	Touch Control System Clock (1:00 - 12:59) Timer (0 - 99 min. 99 seconds) Microwave Power for Variable Cooking Repetition Rate; P-HI Full power throughout the cooking time P-90 approx. 90% of Full Power P-80 approx. 80% of Full Power P-70 approx. 70% of Full Power P-60 approx. 60% of Full Power P-50 approx. 50% of Full Power P-40 approx. 40% of Full Power P-30 approx. 30% of Full Power P-20 approx. 20% of Full Power P-10 approx. 10% of Full Power P-0 No power throughout the cooking time CUSTOM HELP pad, COMPU DEFROST pad, COMPU COOK pad, SENSOR COOKING pad, Number selection pads, POWER LEVEL pad KITCHEN TIMER / CLOCK pad, MINUTE PLUS pad TURNTABLE ON / OFF pad, STOP / CLEAR pad, START / TOUCH ON pad WORK LIGHT pad, NIGHT LIGHT pad, FAN HI / LO pad
Oven Cavity Light	30W x 1 Incandescent light bulb
Safety Standard	UL Listed FCC Authorized DHHS Rules, CFR, Title 21, Chapter 1, Subchapter J
Weight	Approx. 55 lbs.

GENERAL INFORMATION

GROUNDING INSTRUCTIONS

This oven is equipped with a three prong grounding plug. It must be plugged into a wall receptacle that is properly installed and grounded in accordance with the National Electrical Code and local codes and ordinances.

In the event of an electrical short circuit, grounding reduces the risk of electric shock by providing an escape wire for the electric current.

WARNING: Improper use of the grounding plug can result in a risk of electric shock.

Electrical Requirements

The oven is equipped with a 3-prong grounding plug. **DO NOT UNDER ANY CIRCUMSTANCES CUT OR REMOVE THE GROUNDING PIN FROM THE PLUG.**

The power supply cord and plug must be connected to a separate 120 Volt AC, 60 Hz, 15 Amp. or more branch circuit, using a grounded receptacle. The receptacle should be located inside the cabinet directly above the Microwave Oven/Hood system mounting location.

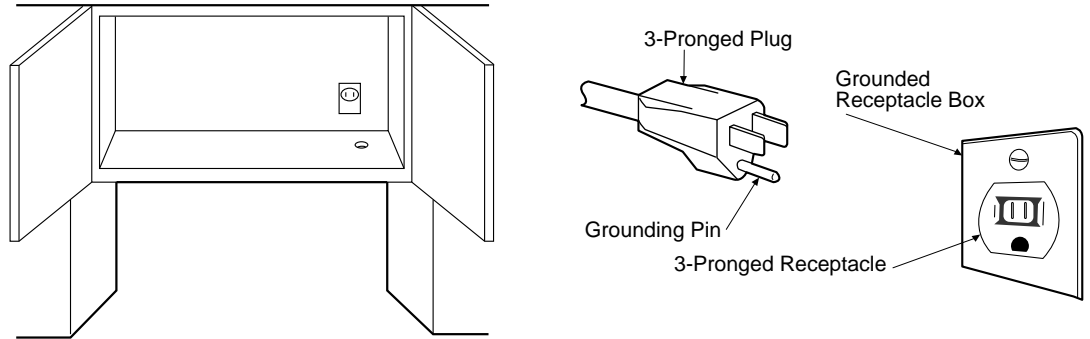

CONTROL PANEL

Sensor Cooking
Custom Help

Popcorn	Baked potato	Reheat
Fresh vegetables	Frozen entrees	Frozen vegetables
Ground meat	Rice	Fish/seafood

Compu Cook

1) 2) 3) 4) 5)

6) 7) 8) 9) 0)

Compu Defrost

Power Level	Kitchen Timer Clock	Minute Plus
Turntable On/Off	Stop Clear	Start Touch On

Work Light

Night Light

Fan Hi/Lo

OPERATION

DESCRIPTION OF OPERATING SEQUENCE

SENSOR COOKING CONDITION

Using the INSTANT SENSOR function, the foods are cooked or defrosted without figuring time, power level or quantity. When the oven senses enough steam from the food, it relays the information to its microprocessor which will calculate the remaining cooking time and power level needed for best results.

When the food is cooked, water vapor is developed. The sensor "senses" the vapor and its resistance increases gradually. When the resistance reaches the value set according to the menu, supplementary cooking is started. The time of supplementary cooking is determined by experiment with each food category and inputted into the LSI. An example of how sensor works (Baked potato):



1. Potatoes at room temperature. Vapor is emitted very slowly.

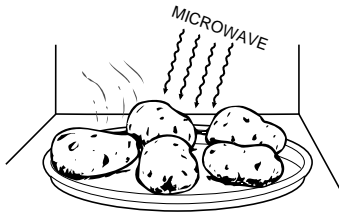

2. Heat potatoes. Moisture and humidity is emitted rapidly. You can smell the aroma as it cooks.

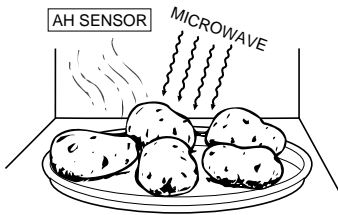

3. Sensor detects moisture and humidity and calculates cooking time and variable power.

Cooking Sequence.

1. Touch one of the INSTANT SENSOR pads.

NOTE: The oven should not be operated on INSTANT SENSOR immediately after plugging in the unit. Wait two minutes before cooking on INSTANT SENSOR.

2. The coil of shut-off relays (RY1 and RY3) are energized, the oven lamp, turntable motor and cooling fan motor are turned on, but the power transformer is not turned on.
3. After about 32 seconds, the cook relay (RY2) is energized. The power transformer is turned on, microwave energy is produced and first stage is started. The 32 seconds is the cooling time required to remove any vapor from the oven cavity and sensor.

NOTE: During this first stage, do not open the door or touch STOP/CLEAR pad.

4. When the sensor detects the vapor emitted from the food, the display switches over to the remaining cooking time and the timer counts down to zero. At this time, the door may be opened to stir food, turn it or season, etc.
5. When the timer reaches zero, an audible signal sounds. The shut-off relay and cook relay are de-energized and the power transformer, oven lamp, etc. are turned off.
6. Opening the door or touching the STOP/CLEAR pad, the time of day will reappear on the display and the oven will revert to an OFF condition.

SCHEMATIC
NOTE: CONDITION OF OVEN
1. DOOR CLOSED
2. CLOCK APPEARS ON DISPLAY

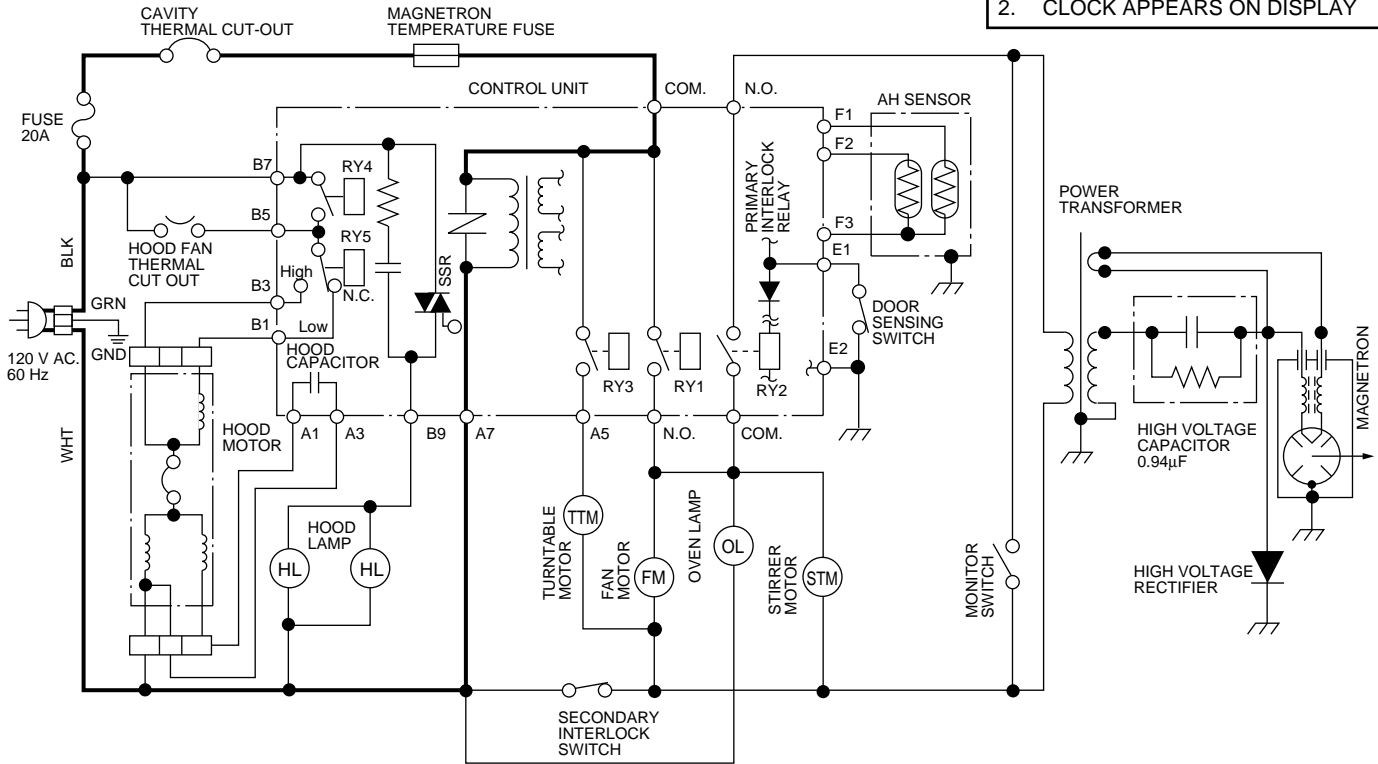

Figure O-1. Oven Schematic-Off Condition

SCHEMATIC
NOTE: CONDITION OF OVEN
1. DOOR CLOSED
2. COOKING TIME PROGRAMMED
3. VARIABLE COOKING CONTROL "HIGH"
4. "START" PAD TOUCHED

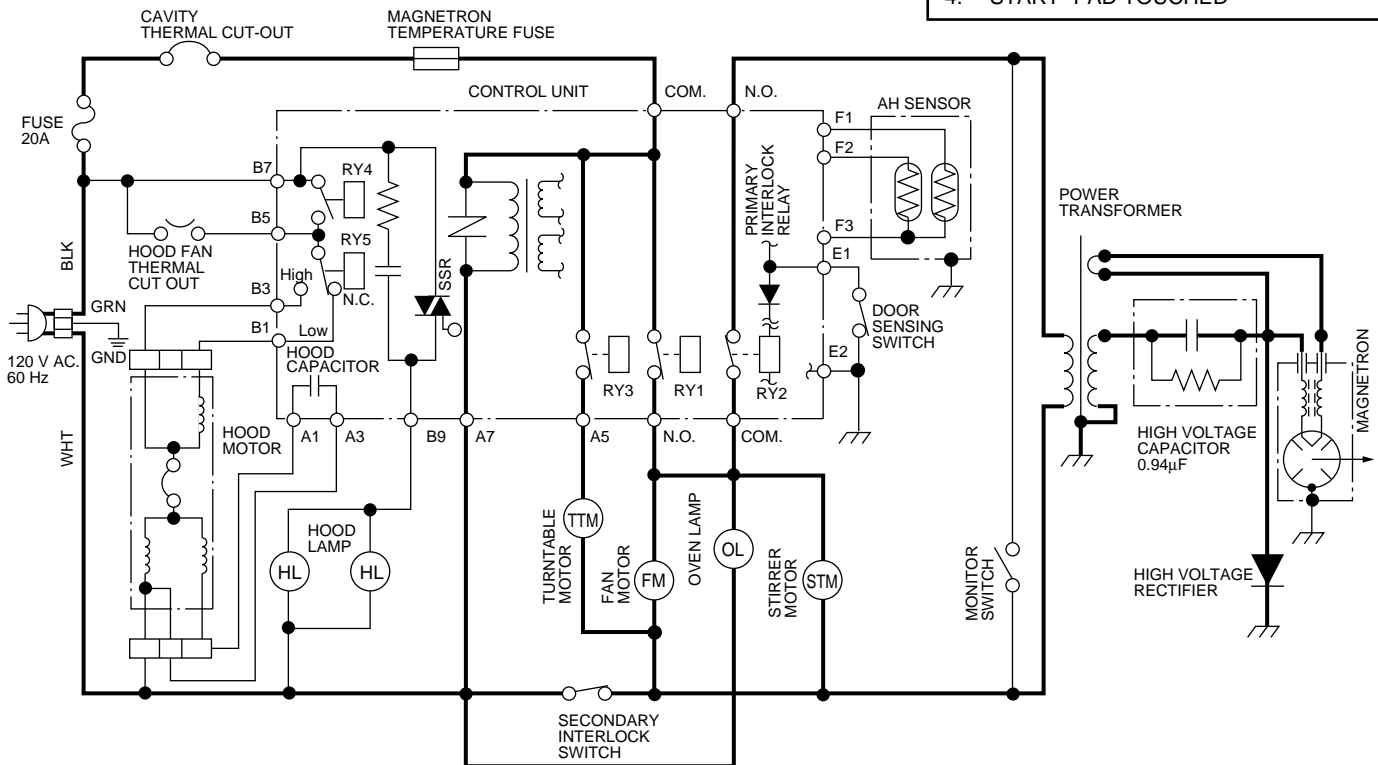

Figure O-2. Oven Schematic-Cooking Condition

TROUBLESHOOTING GUIDE

Never touch any part in the circuit with your hand or an uninsulated tool while the power supply is connected.

When troubleshooting the microwave oven, it is helpful to follow the Sequence of Operation in performing the checks. Many of the possible causes of trouble will require that a specific test be performed. These tests are given a procedure letter which will be found in the "Test Procedure "section.

IMPORTANT: If the oven becomes inoperative because of a blown monitor fuse, check the monitor switch, relay (RY1) primary interlock relay (RY2), door sensing switch and secondary interlock switch before replacing the monitor fuse. If monitor fuse is replaced, the monitor switch must also be replaced. Use part FFS-BA016/ KiT as an assembly.

IMPORTANT: Whenever troubleshooting is performed with the power supply cord disconnected. It may in, some cases, be necessary to connect the power supply cord after the outer case has been removed, in this event,

1. Disconnect the power supply cord, and then remove outer case.
2. Open the door and block it open.
3. Discharge high voltage capacitor.
4. Disconnect the leads to the primary of the power transformer.
5. Ensure that the leads remain isolated from other components and oven chassis by using insulation tape.
6. After that procedure, reconnect the power supply cord.

When the testing is completed

1. Disconnect the power supply cord, and then remove outer case.
2. Open the door and block it open.
3. Discharge high voltage capacitor.
4. Reconnect the leads to the primary of the power transformer.
5. Reinstall the outer case (cabinet).
6. Reconnect the power supply cord after the outer case is installed.
7. Run the oven and check all functions.

TEST PROCEDURE		L	Q	CK
CONDITION	PROBLEM	POSSIBLE CAUSE AND DEFECTIVE PARTS		
		CONTROL UNIT	AH SENSOR	SHORTED OR OPENED WIRING
SENSOR COOKING CONDITION	The oven stops and "ERROR" is displayed or does not end during Sensor Cooking condition. (Oven does not shut off after a cup of water is boiling by Sensor Cooking.)	<input type="radio"/>	<input type="radio"/>	<input type="radio"/>
	Oven stops at 32 seconds after starting.	<input type="radio"/>	<input type="radio"/>	<input type="radio"/>

NOTE: For additional troubleshooting procedures, please refer back to the R-1480 base model Service Manual.

TEST PROCEDURES

PROCEDURE LETTER	COMPONENT TEST
------------------	----------------

M **KEY UNIT TEST**

1. Disconnect the power supply cord, and then remove outer case.
2. Open the door and block it open.
3. Discharge high voltage capacitor.
4. If the display fails to clear when the STOP/CLEAR pad is depressed, first verify the flat ribbon cable is making good contact, verify that the door sensing switch (stop switch) operates properly; that is the contacts are closed when the door is closed and open when the door is open. If the door sensing switch (stop switch) is good, disconnect the flat ribbon cable that connects the key unit to the control unit and make sure the door sensing switch is closed (either close the door or short the door sensing switch connector). Use the Key unit matrix indicated on the control panel schematic and place a jumper wire between the pins that correspond to the STOP/CLEAR pad making momentary contact. If the control unit responds by clearing with a beep the key unit is faulty and must be replaced. If the control unit does not respond, it is faulty and must be replaced. If a specific pad does not respond, the above method may be used (after clearing the control unit) to determine if the control unit or key pad is at fault.
5. Reconnect all leads removed from components during testing.
6. Re-install the outer case (cabinet).
7. Reconnect the power supply cord after the outer case is installed.
8. Run the oven and check all functions.

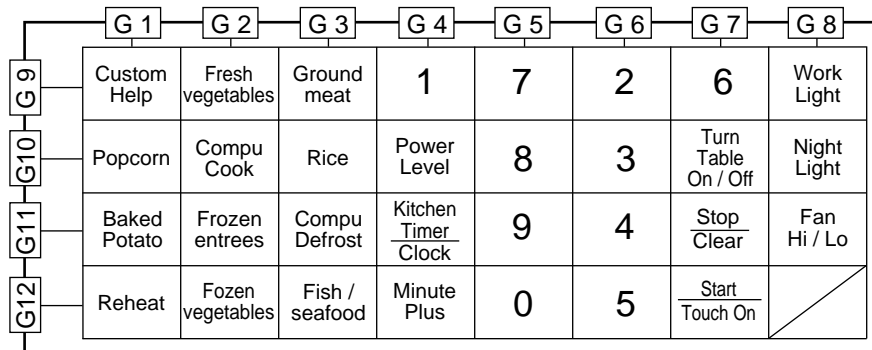

Q **AH SENSOR TEST**

Checking the initial sensor cooking condition

WARNING : The oven should be fully assembled before following procedure.

- (1) The oven should be plugged in at least two minutes before sensor cooking.
- (2) Room temperature should not exceed 95°F (35°C).
- (3) The unit should not be installed in any area where heat and steam are generated. The unit should not be installed, for example, next to a conventional surface unit. Refer to the "INSTALLATION INSTRUCTIONS" of the operation manual.
- (4) Exhaust vents are provided on the back of the unit for proper cooling and air flow in the cavity. To permit adequate ventilation, be sure to install so as not to block these vents. There should be some space for air circulation.
- (5) Be sure the exterior of the cooking container and the interior of the oven are dry. Wipe off any moisture with a dry cloth or paper towel.
- (6) The Sensor works with food at normal storage temperature. For example, chicken pieces would be at refrigerator temperature and canned soup at room temperature.
- (7) Avoid using aerosol sprays or cleaning solvents near the oven while using Sensor settings. The sensor will detect the vapour given of by the spray and turn off before food is properly cooked.
- (8) If the sensor has not detected the vapour of the food, ERROR will appear and the oven will shut off.

Water load cooking test

WARNING : The oven should be fully assembled before following procedure.

Make sure the oven has been plugged in at least two minutes before checking sensor cook operation. The cabinet should be installed and screws tightened.

TEST PROCEDURES

PROCEDURE LETTER	COMPONENT TEST
	<ol style="list-style-type: none">(1) Fill approximately 200 milliliters (7.2 oz) of tap water in a 1000 milliliter measuring cup.(2) Place the container on the center of tray in the oven cavity.(3) Close the door.(4) Touch Reheat pad once and touch the Start pad, Now, the oven is in the sensor cooking condition and "REHEAT" "SENSOR" and "COOK" will appear in the display.(5) The oven will operate for the first 16 seconds, without generating microwave energy. <p>NOTE: ERROR will appear if the door is opened or STOP/CLEAR pad is touched during first stage of sensor cooking.</p> <ol style="list-style-type: none">(6) After approximately 16 seconds, microwave energy is produced, and the display should start to count down the remaining cooking time and oven should turn off after water is boiling (bubbling). <p>If the oven does not turn off, replace the AH sensor or check the control unit, refer to explanation below.</p>

TESTING METHOD FOR AH SENSOR AND/OR CONTROL UNIT

To determine if the sensor is defective, the simplest method is to replace it with a new replacement sensor.

- (1) Disconnect the power supply cord, and then remove outer case.
- (2) Open the door and block it open.
- (3) Discharge high voltage capacitor.
- (4) Remove the AH sensor.
- (5) Install the new AH sensor.
- (6) Reconnect all leads removed from components during replacing.
- (7) Re-install the outer case (cabinet).
- (8) Reconnect the power supply cord after the outer case is installed.
- (9) Reconnect the oven to the power supply cord and check the sensor cook operation proceed as follows:

- 9-1. Fill approximately 200 milliliters (7.2 oz) of tap water in a 1000 milliliter measuring cup.
- 9-2. Place the container on the center of tray in the oven cavity.
- 9-3. Close the door.
- 9-4. Touch reheat pad once and touch the Start pad.
- 9-5. The control panel is in automatic Sensor operation.
- 9-6. The display will start to count down the remaining cooking time, and the oven will turn off automatically after the water is boiling (bubbling).

If new sensor dose not operate properly, the problem is with the control unit, and refer to explanation below.

CHECKING CONTROL UNIT

- (1) Disconnect the power supply cord, and then remove outer case.
- (2) Open the door and block it open.
- (3) Discharge high voltage capacitor.
- (4) Disconnect the sensor connector that is mounted to control panel.
- (5) Then connect the dummy resistor circuit (see fig.) to the sensor connector of control panel.
- (6) Disconnect the leads to the primary of the power transformer.
- (7) Ensure that these leads remain isolated from other components and oven chassis by using insulation tape.
- (8) After that procedure, re-connect the supply.
- (9) Check the sensor cook operation proceed as follows:
 - 9-1. Touch reheat pad once and touch the Start pad.
 - 9-2. The control panel is in the sensor cooking operation.
 - 9-3. After approximately 32 seconds, push plunger of select switch for more than 3 seconds. This condition is same as judgement by AH sensor.
 - 9-4. After approximately 3 seconds, the display shows " X X . X X " which is the remaining cooking time, and the display count down.

If the above is not the case, the control unit is probably defective.
If the above is proper, the AH sensor is probably defective.
- (10) Disconnect the power supply cord, and then remove outer case.

TEST PROCEDURES

PROCEDURE LETTER	COMPONENT TEST
------------------	----------------

- (11) Open the door and block it open.
- (12) Discharge high voltage capacitor.
- (13) Disconnect the dummy resistor circuit from the sensor connector of control panel.
- (14) Carry out necessary repair.
- (15) Reconnect all leads removed from components during testing and repairing.
- (16) Re-install the outer case (cabinet).
- (17) Reconnect the power supply cord after the outer case is installed. Run the oven and check all functions.
- (18) Carry out "Water load cooking test" again and ensure that the oven works properly.

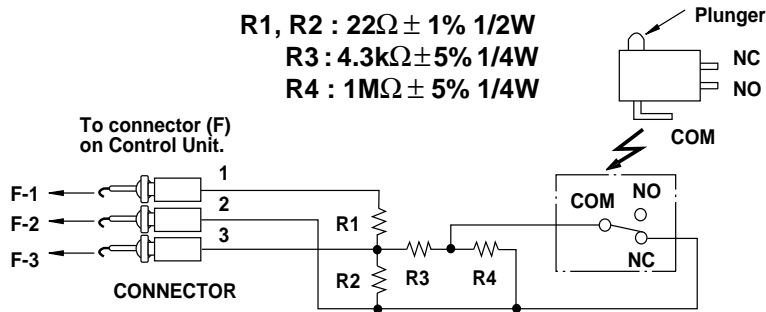

Sensor Dummy Resistor Circuit

TOUCH CONTROL PANEL ASSEMBLY

OUTLINE OF TOUCH CONTROL PANEL

1) LSI

This LSI controls the AH sensor signal, key strobe signal, relay driving signal for oven function and indicator signal.

DESCRIPTION OF LSI

LSI(IZA877DR)

The I/O signals of the LSI(IZA877DR) are detailed in the following table.

Pin No.	Signal	I/O	Description
			NOTE: For additional informations of LSI, please refer back to the R-1480 base model Service Manual.
5	AN7	IN	Used for initial balancing of the bridge circuit (absolute humidity sensor). This input is an analog input terminal from the AH sensor circuit, and connected to the A/D converter built into the LSI.
6	AN6	IN	AH sensor input. This input is an analog input terminal from the AH sensor circuit, and connected to the A/D converter built into the LSI.
60-64	P34-P30	OUT	Used for initial balancing of the bridge circuit (absolute humidity sensor).

ABSOLUTE HUMIDITY SENSOR CIRCUIT

(1) Structure of Absolute Humidity Sensor

The absolute humidity sensor includes two thermistors as shown in the illustration. One thermistor is housed in the closed vessel filled with dry air while another in the open vessel. Each sensor is provided with the protective cover made of metal mesh to be protected from the external airflow.

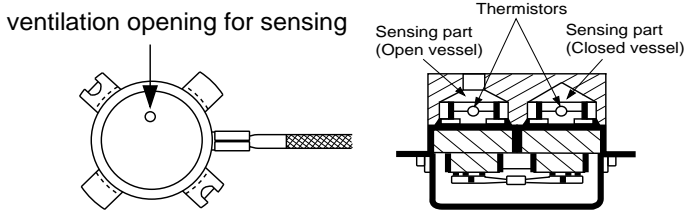

(2) Operational Principle of Absolute Humidity Sensor

The figure below shows the basic structure of an absolute humidity sensor. A bridge circuit is formed by two thermistors and two resistors (R1 and R2).

The output of the bridge circuit is to be amplified by the operational amplifier.

Each thermistor is supplied with a current to keep it heated at about 150°C (302°F), the resultant heat is dissipated in the air and if the two thermistors are placed in different humidity conditions they show different degrees of heat conductivity leading to a potential difference between them causing an output voltage from the bridge circuit, the intensity of which is increased as the absolute humidity of the air increases. Since the output is very minute, it is amplified by the operational amplifier.

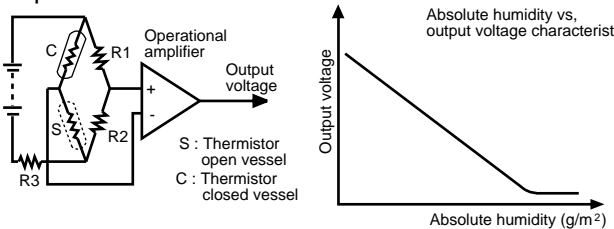

(3) Detector Circuit of Absolute Humidity Sensor Circuit

This detector circuit is used to detect the output voltage of the absolute humidity circuit to allow the LSI to control sensor cooking of the unit. When the unit is set in the sensor cooking mode, a 16 seconds clearing cycle occurs. Then the detector circuit starts to function and the LSI observes the initial voltage available at its AN6 terminal.

With this voltage given, the switches SW1 to SW5 in the LSI are turned on in such a way as to change the resistance values in parallel with R50-1. Changing the resistance values results in that there is the same potential at both F-3 terminal of the absolute humidity sensor and AN7 terminal of the LSI. The voltage of AN6 terminal will indicate about -2.5V. This initial balancing is set up about 16 seconds after the unit is put in the Sensor Cooking mode. As the sensor cooking proceeds,

the food is heated to generate moisture by which the resistance balance of the bridge circuit is deviated to increase the voltage available at AN6 terminal of the LSI. Then the LSI observes that voltage at AN6 terminal and compares it with its initial value, and when the comparison rate reaches the preset value (fixed for each menu to be cooked), the LSI causes the unit to stop sensor cooking; thereafter, the unit goes in the next operation automatically.

After 16 seconds of operation in the sensor cook mode, the LSI detects the initial voltage at AN6. If the absolute humidity sensor is open or shorted, the circuit can not be balanced for initial voltage comparisons. This will result in the word "error" on the display and the cooking operation is stopped.

1) Absolute humidity sensor circuit

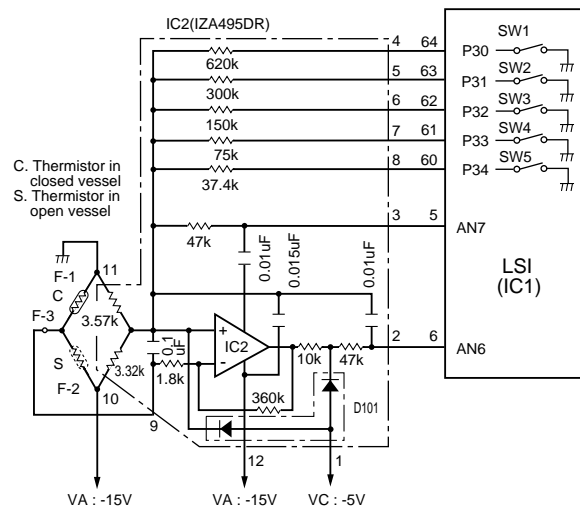

COMPONENT REPLACEMENT AND ADJUSTMENT PROCEDURE

WARNING AGAINST HIGH VOLTAGE:

Microwave ovens contain circuitry capable of producing very high voltage and current, contact with following parts may result in severe, possibly fatal, electric shock.

(Example)

High Voltage Capacitor, Power Transformer, Magnetron, High Voltage Rectifier Assembly, High Voltage Harness etc..

WARNING: Avoid possible exposure to microwave energy. Please follow the instructions below before operating the oven.

1. Disconnect the power supply cord.
2. Visually check the door and cavity face plate for damage (dents, cracks, signs of arcing etc.).

Carry out any remedial work that is necessary before operating the oven.

Do not operate the oven if any of the following conditions exist;

1. Door does not close firmly.
2. Door hinge, support or latch hook is damaged.
3. The door gasket or seal is damaged.

4. The door is bent or warped.
5. There are defective parts in the door interlock system.
6. There are defective parts in the microwave generating and transmission assembly.
7. There is visible damage to the oven.

Do not operate the oven:

1. Without the RF gasket (Magnetron).
2. If the wave guide or oven cavity are not intact.
3. If the door is not closed.
4. If the outer case (cabinet) is not fitted.

WARNING FOR WIRING

To prevent an electric shock, take the following precautions.

1. Before wiring,
 - 1) Disconnect the power supply cord.
 - 2) Open the door block it open.
 - 3) Discharge the high voltage capacitor and wait for 60 seconds.
2. Don't let the wire leads touch to the following parts;
 - 1) High voltage parts:
Magnetron, High voltage transformer, High voltage capacitor and High voltage rectifier assembly.
 - 2) Hot parts:
Oven lamp, Magnetron, High voltage transformer and Oven cavity.

- 3) Sharp edge:
Bottom plate, Oven cavity, Waveguide flange, Chassis support and other metallic plate.
- 4) Movable parts (to prevent a fault)
Fan blade, Fan motor, Switch, Switch lever, Open button.
3. Do not catch the wire leads in the outer case cabinet.
4. Insert the positive lock connector until its pin is locked and make sure that the wire leads do not come off even if the wire leads are pulled.
5. To prevent an error function, connect the wire leads correctly, referring to the Pictorial Diagram.

Please refer to 'OVEN PARTS, CABINET PARTS, CONTROL PANAL PARTS, DOOR PARTS', when carrying out any of the following removal procedures:

HOOD FAN MOTOR, HOOD DUCT, OVEN LAMP SOCKET AND AH. SENSOR REMOVAL

1. Disconnect the power supply cord and remove the oven from wall and remove outer case. (Refer to procedure of "Removal of Oven from Wall" and "Outer case Removal")
2. Open the door and block it open.
3. Discharge high voltage capacitor.
4. Disconnect the 6-pin connector of the hood fan motor from the main wire harness located at the right edge of the hood duct and release the snap band from the hood duct.
5. Remove the hood fan motor from the hood duct by lifting it up.
6. Now, the hood fan motor is free.
7. Disconnect the connector CN-F from the control unit.
8. Remove one (1) screw holding the hood duct to the oven cavity front plate.
9. Release the 6-pin connector and the 3-pin connector of the main harness A from the hood duct.
10. Disconnect the wire leads from the fan motor and chassis support, and release the wire leads from holes of the hood duct.
11. Remove the two (2) unit mounting screws from the chassis support (right side) and the hood duct (left side).
12. Remove the one (1) screw holding the chassis support.
13. Remove the chassis support.
14. Remove the hood duct from the oven cavity by lifting it up.

15. Screw the oven lamp off from the lamp socket.
16. Remove the lamp socket from the lamp angle.
17. Pull the wire leads from the oven lamp socket by pushing the terminal hole of the oven lamp socket with a small flat type screw driver.
18. Now, the oven lamp socket is free.
19. Release the harness of the AH sensor assembly from three (3) wire holders of the hood duct.
20. Remove two (2) screws holding the AH sensor assembly to the hood duct.
21. Now, the AH sensor assembly is free.

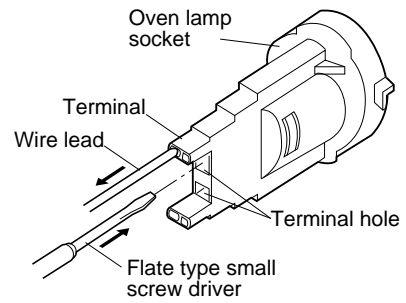

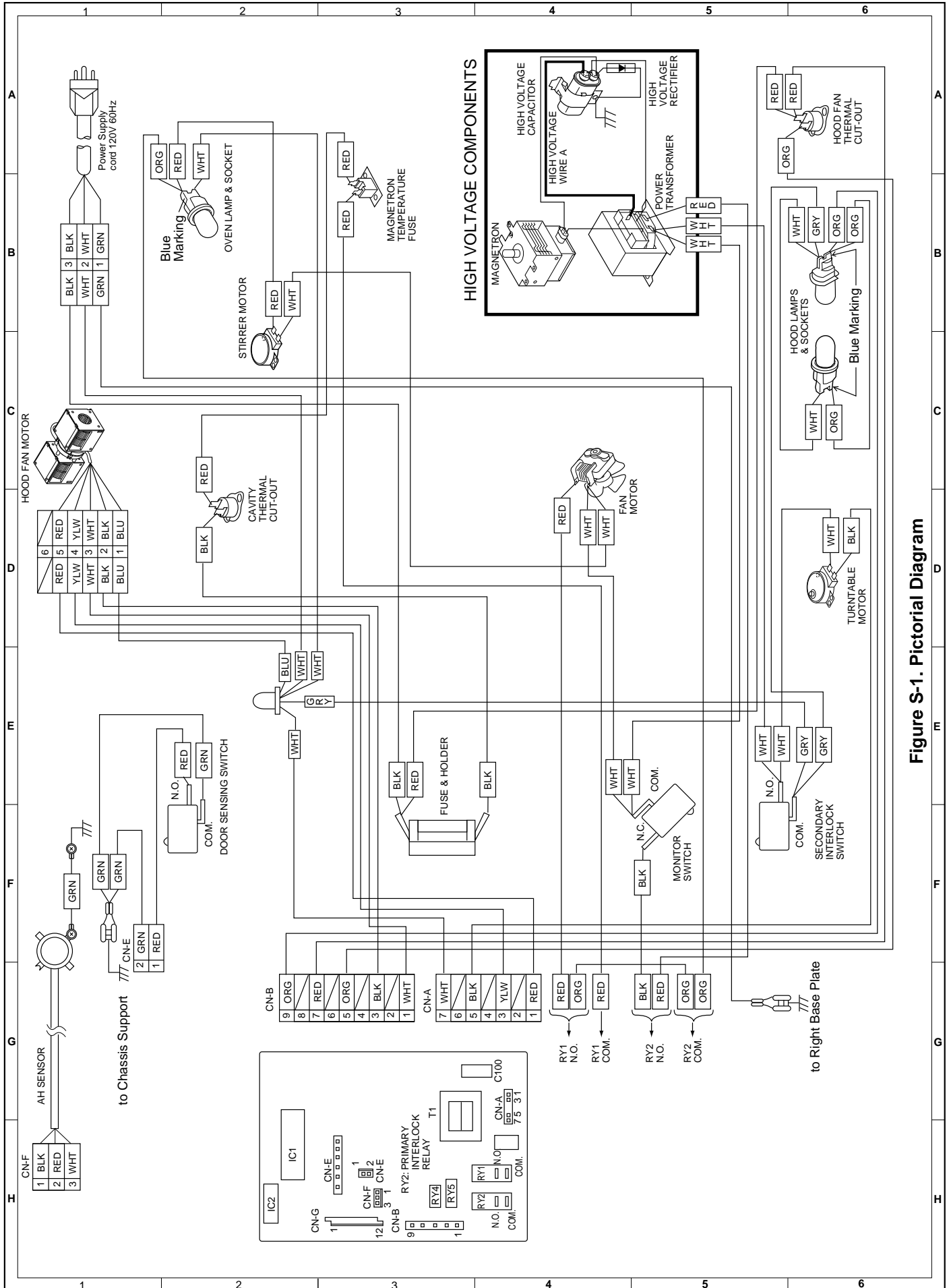

Figure S-1. Pictorial Diagram

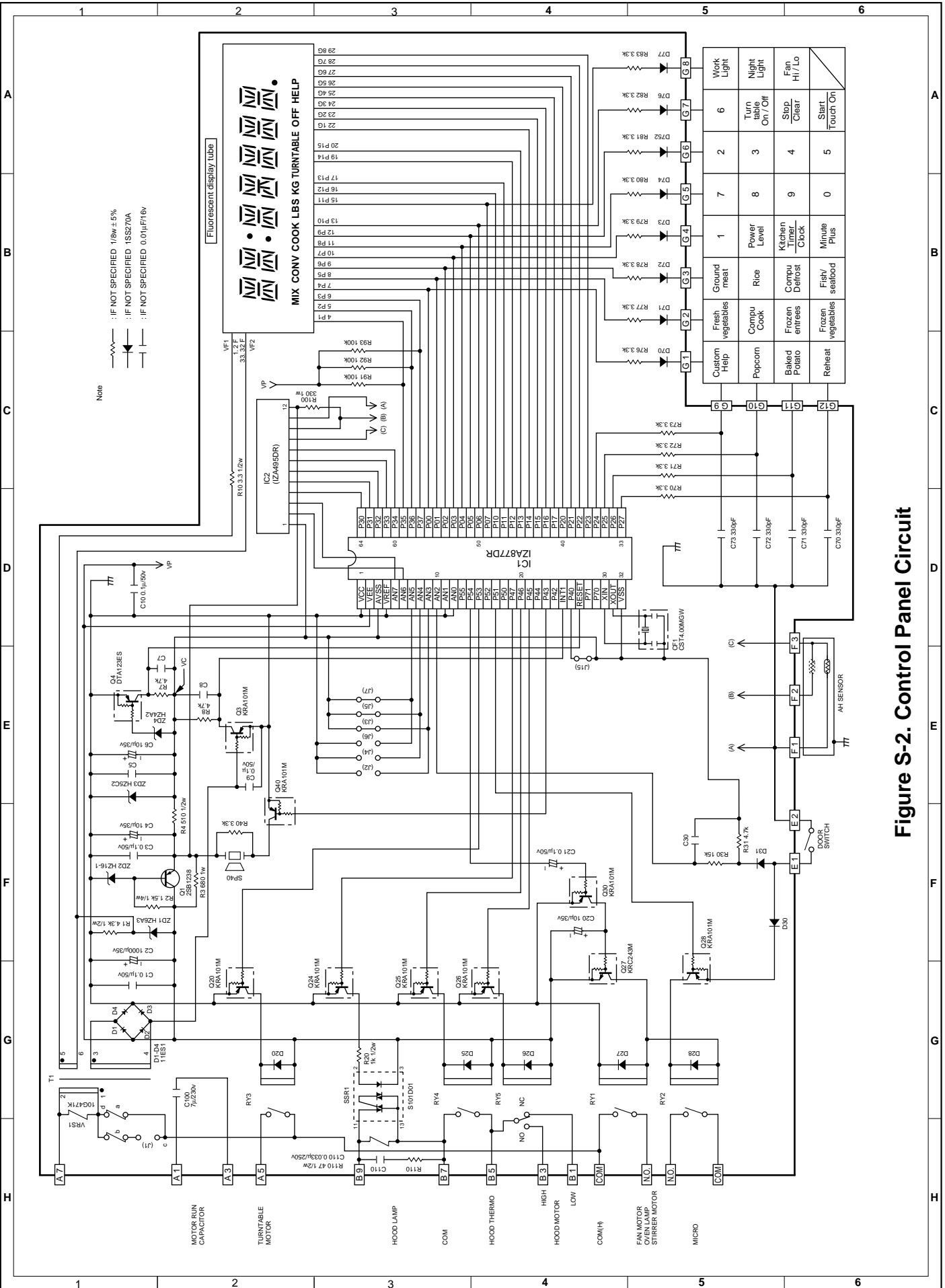

Figure S-2. Control Panel Circuit

PARTS LIST

**Note: The parts marked "Δ" may cause undue microwave exposure.
The parts marked "*" are used in voltage more than 250V.**

"§" MARK: PARTS DELIVERY SECTION

REF. NO.	PART NO.	§	DESCRIPTION	Q'TY	CODE
ELECTRIC PARTS					
* 1- 1	FH-DZB012MRY0	M	High voltage rectifier assembly	1	AK
* 1- 2	RC-QZA173WRE0	M	High voltage capacitor	1	AR
1- 3	QFS-TA013WRE0	M	Temperature fuse 150°C (Magnetron)	1	AG
1- 4	RMOTDA182WRE0	M	Turntable motor	1	AQ
1- 5	RMOTDA214WRE0	M	Stirrer motor	1	AQ
1- 6	RTHM-B005MRE0	M	Thermal cut-out N.O. 60°C (Hood Fan)	1	AG
* 1- 7	RTRN-B055MRE0	M	Power transformer	1	BE
Δ* 1- 8	RV-MZA280WRE0	M	Magnetron	1	BD
1- 9	QFSHDB003MRE0	M	Fuse holder	1	AD
1-10	QSW-MA110WRE0	M	Secondary interlock and door sensing switches	2	AE
1-11	FFS-BA016/KIT	M	Monitor switch with fuse assembly	1	AF
1-12	FACCDB011MRE0	M	Power supply cord	1	AP
1-13	QSOCLB006MRE0	M	Oven lamp socket	3	AE
1-14	FMOTEA366WRK0	M	Hood fan motor	1	BE
1-15	RMOTEA346WRE0	M	Fan motor	1	AR
1-16	RLMPTA071WRE0	M	Oven lamp	3	AG
1-17	RTHM-A080WRE0	M	Thermal cut-out 145°C (Cavity)	1	AG
1-18	FDTCTA191WRK0	M	AH sensor	1	AQ

CABINET PARTS

2- 1	LSTY-B021MRP0	M	Rear stay	1	AF
2- 2	PDIF-B018MRF0	M	Hood exhaust louver [R-1490]	1	AT
2- 2	PDIF-B019MRF0	M	Hood exhaust louver [R-1491]	1	AT
2- 2	PDIF-B020MRF0	M	Hood exhaust louver [R-1492]	1	AT
2- 3	GDAl-B045MRP0	M	Right base plate	1	AM
2- 4	PCUSUB040MRP0	M	Base cover cushion	1	AA
2- 5	GCABUB084MRP0	M	Outer case cabinet [R-1490]	1	BA
2- 5	GCABUB085MRP0	M	Outer case cabinet [R-1491]	1	BB
2- 5	GCABUB086MRP0	M	Outer case cabinet [R-1492]	1	BC
2- 6	TMAPCB052MRR0	M	Schematic diagram	1	AB
2- 7	FANGKB009MRY0	M	Hood lamp glass assembly [R-1490]	1	AN
2- 7	FANGKB010MRY0	M	Hood lamp glass assembly [R-1491]	1	AM
2- 7	FANGKB011MRY0	M	Hood lamp glass assembly [R-1492]	1	AM
2-7-1	LANGQB016MRP0	M	Hood lamp glass angle [R-1490]	1	AG
2-7-1	LANGQB020MRP0	M	Hood lamp glass angle [R-1491]	1	AG
2-7-1	LANGQB027MRP0	M	Hood lamp glass angle [R-1492]	1	AG
2-7-2	PGLSPB004MRE0	M	Hood lamp glass	1	AH
2- 8	PCOVPB064MRt0	M	Base cover [R-1490]	1	AY
2- 8	PCOVPB066MRt0	M	Base cover [R-1491]	1	AY
2- 8	PCOVPB067MRt0	M	Base cover [R-1492]	1	AY

CONTROL PANEL PARTS

3- 1	DPWFBF083MRU0	M	Control unit	1	BL
3- 1A	QCNCMA447DRE0	M	4-pin connector CN-A	1	AA
3- 1B	QCNCMA448DRE0	M	5-pin connector CN-B	1	AA
3- 1C	QCNCMA275DRE0	J	2-pin connector CN-E	1	AB
3- 1D	QCNCMA237DRE0	J	3-pin connector CN-F	1	AD
3- 1E	QCNCWA030DRE0	J	12-pin connector CN-G	1	AE
3- 1F	RV-KXB004MRE0	M	Fluorescent display tube	1	AS
3- 1G	PTPEHB010MRE0	M	Tape 2mm	1	AB
C1	RC-KZA087DRE0	J	Capacitor 0.1 uF 50V	1	AB
C2	VCEAB31VW108M	J	Capacitor 1000 uF 35V	1	AF
C3	RC-KZA087DRE0	J	Capacitor 0.1 uF 50V	1	AB
C4	VCEAB31VW106M	J	Capacitor 10 uF 35V	1	AB
C5	VCKYD11CY103N	J	Capacitor 0.01 uF 16V	1	AH
C6	VCEAB31VW106M	J	Capacitor 10 uF 35V	1	AB
C7-8	VCKYD11CY103N	J	Capacitor 0.01 uF 16V	2	AH
C9-10	RC-KZA087DRE0	J	Capacitor 0.1 uF 50V	2	AB
C20	VCEAB31VW106M	J	Capacitor 10 uF 35V	1	AB
C21	VCEAB31HW104M	J	Capacitor 0.1 uF 50V	1	AM
C30	VCKYD11CY103N	J	Capacitor 0.01 uF 16V	1	AH
C70-73	VCKYD11HB331K	J	Capacitor 330 pF 50V	4	AA
C100	RC-QZB014MRE0	M	Capacitor 7 uF 230V	1	AK
C110	RC-QZB019MRE0	M	Capacitor 0.033 uF 250V	1	AC
CF1	RCRS-A010DRE0	J	Ceramic resonator (CST4.00MGW)	1	AD
D1-4	VHD11ES1///-1	J	Diode (11ES1)	4	AB

REF. NO.	PART NO.	§	DESCRIPTION	Q'TY	CODE
D20	VHD1SS270A/-1	J	Diode (1SS270A)	1	AA
D25-28	VHD1SS270A/-1	J	Diode (1SS270A)	4	AA
D30-31	VHD1SS270A/-1	J	Diode (1SS270A)	2	AA
D70-77	VHD1SS270A/-1	J	Diode (1SS270A)	8	AA
IC1	RH-IZA877DRE0	J	LSI	1	AP
IC2	RH-IZA495DRE0	J	IC	1	AL
Q1	VS2SB1238//-3	J	Transistor (2SB1238)	1	AA
Q3	VSKRA101M//-3	J	Transistor (KRA101M)	1	AB
Q4	VSDTA123ES/-3	J	Transistor (DTA123ES)	1	AA
Q20	VSKRA101M//-3	J	Transistor (KRA101M)	1	AB
Q24-26	VSKRA101M//-3	J	Transistor (KRA101M)	3	AB
Q27	VSKRC243M//-3	J	Transistor (KRC243M)	1	AB
Q28	VSKRA101M//-3	J	Transistor (KRA101M)	1	AB
Q30	VSKRA101M//-3	J	Transistor (KRA101M)	1	AB
R1	VRD-B12HF432J	J	Resistor 4.3k ohm 1/2W	1	AH
R2	VRD-B12EF152J	J	Resistor 1.5k ohm 1/4W	1	AA
R3	VRS-B13AA681J	J	Resistor 680 ohm 1W	1	AA
R4	VRD-B12HF511J	J	Resistor 510 ohm 1/2W	1	AB
R7-8	VRD-B12EF472J	J	Resistor 4.7k ohm 1/4W	2	AA
R10	VRD-B12HF3R3J	J	Resistor 3.3 ohm 1/2W	1	AH
R20	VRD-B12HF102J	J	Resistor 1k ohm 1/2W	1	AA
R30	VRD-B12EF153J	J	Resistor 15k ohm 1/4W	1	AA
R31	VRD-B12EF472J	J	Resistor 4.7k ohm 1/4W	1	AA
R40	VRD-B12EF332J	J	Resistor 3.3k ohm 1/4W	1	AA
R70-73	VRD-B12EF332J	J	Resistor 3.3k ohm 1/4W	4	AA
R76-83	VRD-B12EF332J	J	Resistor 3.3k ohm 1/4W	8	AA
R91-93	VRD-B12EF104J	J	Resistor 100k ohm 1/4W	3	AA
R100	VRS-B13AA331J	J	Resistor 330 ohm 1W	1	AA
R110	VRS-A12HA470J	J	Resistor 47 ohm 1/2W	1	AH
RY1-2	RRLY-A113DRE0	M	Relay (DU24D1-1PR(M))	2	AG
RY3-4	RRLY-A080DRE0	J	Relay (OJ-SH-124LM)	2	AG
RY5	RRLY-A112DRE0	M	Relay (VE24HSE-K)	1	AH
SSR1	RH-SZA009DRE0	M	Solid state relay	1	AG
SP40	RALM-A014DRE0	J	Buzzer (PKM22EPT)	1	AG
T1	RTRNPB014MRE0	M	Transformer	1	AM
VRS1	RH-VZA032DRE0	J	Varistor (10G471K)	1	AE
ZD1	VHEHZ6A3///-1	J	Zener diode (HZ6A-3)	1	AC
ZD2	VHEHZ161///-1	J	Zener diode (HZ16-1)	1	AA
ZD3	VHEHZ5C2///-1	J	Zener diode (HZ5C-2)	1	AA
ZD4	VHEHZ4A2///-1	J	Zener diode (HZ4A-2)	1	AA
3- 2	FPNLCB213MRK0	M	Control panel sub. assembly [R-1490]	1	AZ
3- 2	FPNLCB214MRK0	M	Control panel sub, assembly [R-1491]	1	AZ
3- 2	FPNLCB215MRK0	M	Control panel sub, assembly [R-1492]	1	AZ
3- 2-1	FUNTKB161MRE0	M	Key unit [R-1490]	1	AU
3- 2-1	FUNTKB162MRE0	M	Key unit [R-1491]	1	AU
3- 2-1	FUNTKB163MRE0	M	Key unit [R-1492]	1	AU
3- 2-2	GMADIB030MRF0	M	Display window	1	AF
3- 3	XEPSD30P10XS0	M	Screw; 3mm x 10mm	5	AB

OVEN PARTS

4- 1	FFTA-B003MRK0	M	Exhaust damper assembly	1	AH
4- 2	FROLPB024MRK0	M	Turntable support assembly	1	AK
4- 3	NTNT-A090WRE0	M	Turntable tray	1	AN
4- 4	LANGKB010MRF0	M	Capacitor holder	1	BB
4- 5	FCOVBP012MRY0	M	Stirrer cover assembly	1	AK
4- 6	FFAN-B006MRK0	M	Stirrer fan assembly	1	AL
4- 7	*****	M	Oven cavity (Not replaceable part)	1	--
4- 8	PPACGB014MRF0	M	Turntable motor packing	1	AA
4- 9	PHOK-B017MRF0	M	Latch hook	1	AG
4-10	LANGTB036MRP0	M	Unit mounting plate	1	AP
4-11	NFANPB001MRE0	M	Fan blade	1	AC
4-12	LBSHC0037WRE0	M	Cord bushing	1	AB
4-13	PCOVBP065MRP0	M	Oven lamp cover	1	AD
4-14	PDUC-B077MRP0	M	Hood intake duct	1	AG
4-15	PCUSUB039MRP0	M	Hood intake duct cushion	2	AA
4-16	PFILWB005MRP0	M	Lamp filter	1	AB
4-17	PSKR-B012MRP0	M	Magnetron air guide	1	AB
4-18	LANGTB040MRP0	M	Chassis support	2	AE
4-19	PDUC-B078MRF0	M	Hood duct	1	AX
4-20	PCUSUB043MRP0	M	Hood duct cushion	1	AB
4-21	LSTPPB031MRF0	M	Door stopper	1	AC
4-22	PCUSUB045MRP0	M	Cushion	1	AE
4-23	PCUSUB044MRP0	M	Sensor cushion	3	AB

REF. NO.	PART NO.	§	DESCRIPTION	Q'TY	CODE
4-24	PCUSUB034MRP0	M	Cab. cushion	1	AB

DOOR PARTS

Δ	5	CDORFB203MRK0	M	Door assembly [R-1490]	1	BD
Δ	5	CDORFB205MRK0	M	Door assembly [R-1491]	1	BE
Δ	5	CDORFB206MRK0	M	Door assembly [R-1492]	1	BE
Δ	5- 1	FDORFB060MRT0	M	Door panel assembly	1	AX
Δ	5- 2	FCOV-B125MRK0	M	Door frame assembly [R-1490]	1	AS
Δ	5- 2	FCOV-B127MRK0	M	Door frame assembly [R-1491]	1	AS
Δ	5- 2	FCOV-B128MRK0	M	Door frame assembly [R-1492]	1	AS
Δ	5-2-1	PGLSPB012MRE0	M	Front door glass [R-1490]	1	AQ
Δ	5-2-1	PGLSPB014MRR0	M	Front door glass [R-1491]	1	AQ
Δ	5-2-1	PGLSPB013MRR0	M	Front door glass [R-1492]	1	AQ
Δ	5-2-2	LSTPPB030MRF0	M	Latch head	1	AC
Δ	5-2-3	LSTPPB032MRF0	M	Glass stopper	1	AC
Δ	5-2-4	MSPRTA046WRE0	M	Latch spring	1	AB
Δ	5- 3	GCOVHB035MRF0	M	Choke cover	1	AG
Δ	5- 4	PSHEPB024MRE0	M	Sealer film	1	AF
Δ	5- 5	JHNDPB007MRF0	M	Door handle [R-1490]	1	AK
Δ	5- 5	JHNDPB008MRF0	M	Door handle [R-1491]	1	AK
Δ	5- 5	JHNDPB009MRF0	M	Door handle [R-1492]	1	AK
Δ	5- 6	XCPD40P08000	M	Screw : 4mm x 8mm	6	AA

MISCELLANEOUS

	6- 1	CFZK-B131MRK0	M	Installation material assembly	1	AM
	6-1-1	LBHC0040MRE0	M	Grommet	1	AC
	6-1-2	LX-BZ0195WRE0	M	Toggle screw	4	AC
	6-1-3	LX-MZ0001WRE0	M	Cord holder	1	AC
	6-1-4	XBRSD50P60000	M	Screw : 5mm x 60mm	2	AC
	6-1-5	XOTSD40P12000	M	Screw : 4mm x 12mm	1	AA
	6-1-6	XTSSD50P35000	M	Screw : 5mm x 35mm	6	AA
	6-1-7	XWHSD50-16300	M	Washer	2	AA
	6- 2	TINSEB177MRR0	M	Installation instruction	1	AB
	6- 3	TINSEB181MRR0	M	Operation manual	1	AD
	6- 4	TINSKB047MRR0	M	Top template	1	AC
	6- 5	TINSKB048MRR0	M	Wall template	1	AB
*	6- 6	QW-QZB023MRE0	M	High voltage wire A	1	AD
	6- 7	FW-VZB145MRE0	M	Main harness A	1	AU
	6- 8	TCAUAA025WRR0	M	Caution label	1	AA
	6- 9	TCAUAB015MRR0	M	Monitor caution label	1	AA
	6-10	TCAUAB005MRR0	M	DHHS caution label	1	AB
	6-11	FW-VZB149MRE0	M	Stop switch harness	1	AM
	6-12	PFIL-B004MRE0	M	Chacoal filter	1	AH
	6-13	PFIL-B002MRE0	M	Grease filter	1	AF
	6-14	PCLIC0020MRE0	M	Canoe clip	1	AA
	6-15	TLAB-B033MRR0	M	Menu label	1	AB
	6-16	QW-QZB008MRE0	M	Sensor grounding wire	1	AC

SCREWS,NUTS AND WASHERS

	7- 1	XCPD40P08000	M	Screw : 4mm x 8mm	3	AA
	7- 2	XOTSF40P12000	M	Screw : 4mm x 12mm [R-1490]	4	AB
	7- 2	XOTSE40P12000	M	Screw : 4mm x 12mm [R-1491]	4	AA
	7- 2	XOTSD40P12000	M	Screw : 4mm x 12mm [R-1492]	4	AA
	7- 3	XOTSD40P12000	M	Screw : 4mm x 12mm	24	AA
	7- 4	XBTS40P08000	M	Screw : 4mm x 8mm	2	AA
	7- 5	LX-CZA038WRE0	M	Special screw	4	AA
	7- 6	LX-CZ0052WRE0	M	Special screw	2	AA
	7- 7	LX-BZ0081YBE0	M	Screw : 4mm x 8mm	5	AA
	7- 8	XCPD30P08000	M	Screw : 4mm x 8mm	4	AA
	7- 9	LX-BZB012MRE0	M	Unit mounting screw	2	AD
	7-10	XCBSD30P08000	M	Screw : 4mm x 8mm	4	AA

HOW TO ORDER REPLACEMENT PARTS

To have your order filled promptly and correctly, please furnish the following information.

1. MODEL NUMBER 2. REF. NO. 3. PART NO. 4. DESCRIPTION

Order Parts from the authorized SHARP parts Distributor for your area.

Defective parts requiring return should be returned as indicated in the Service Policy.

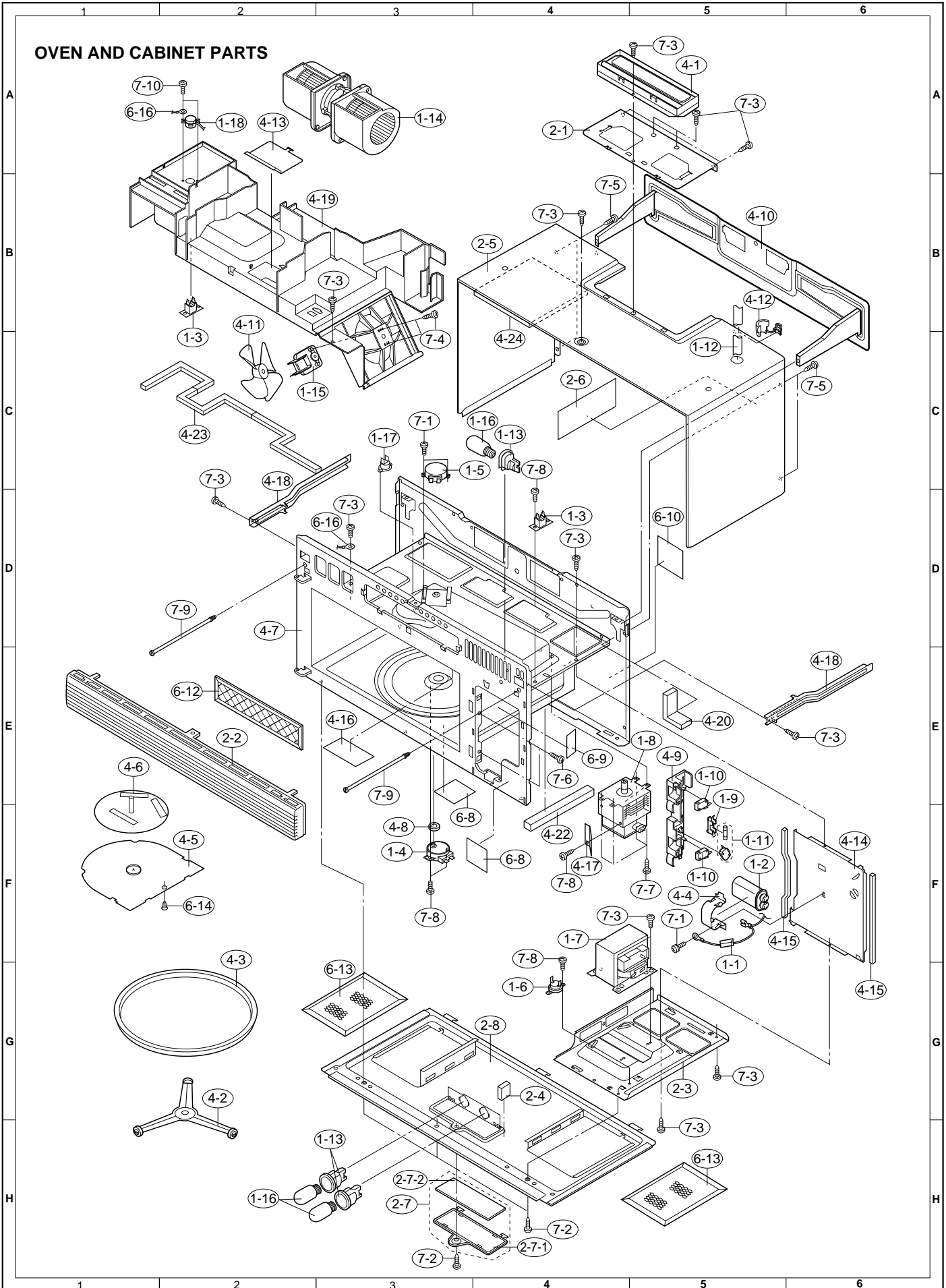

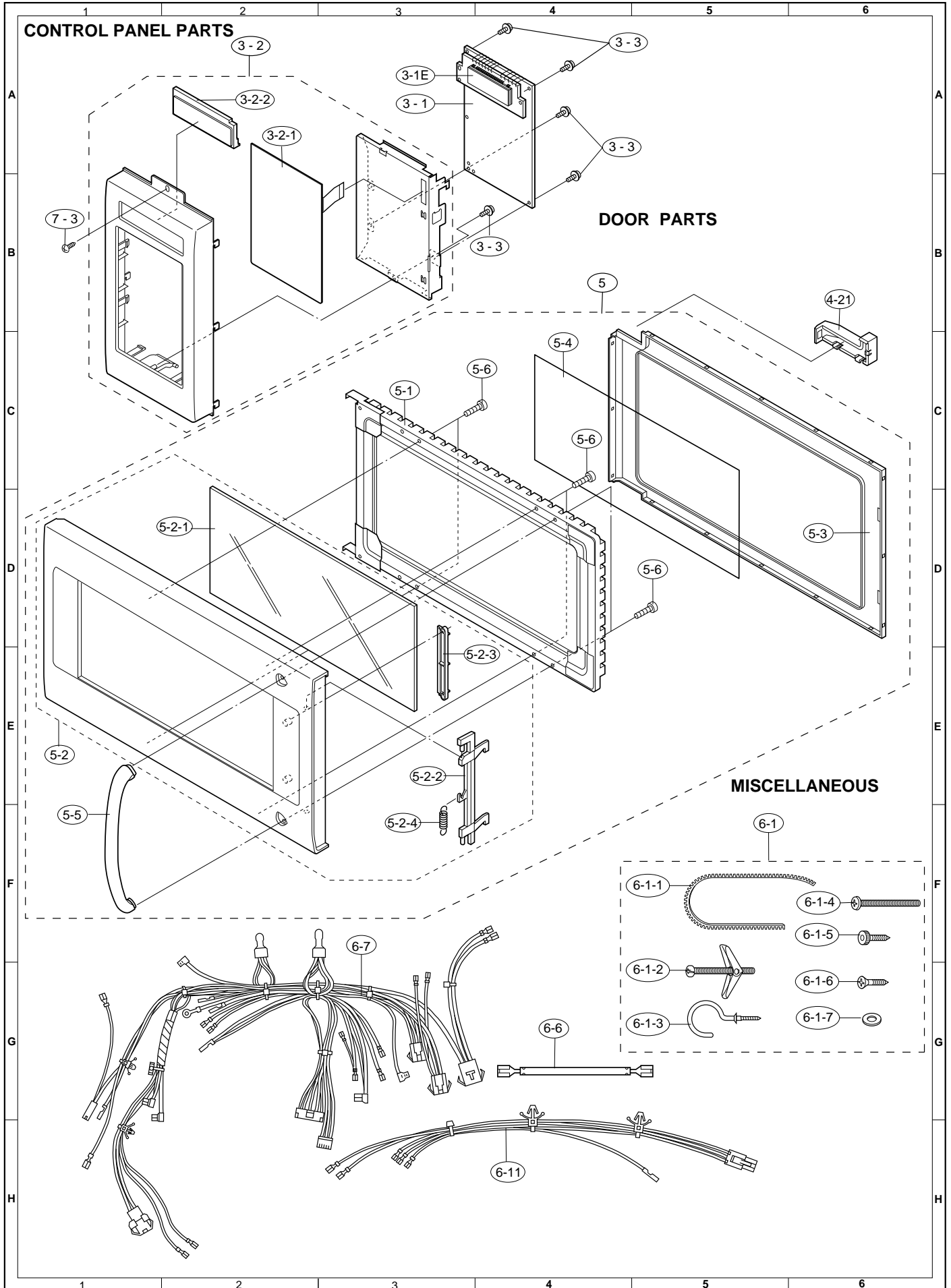

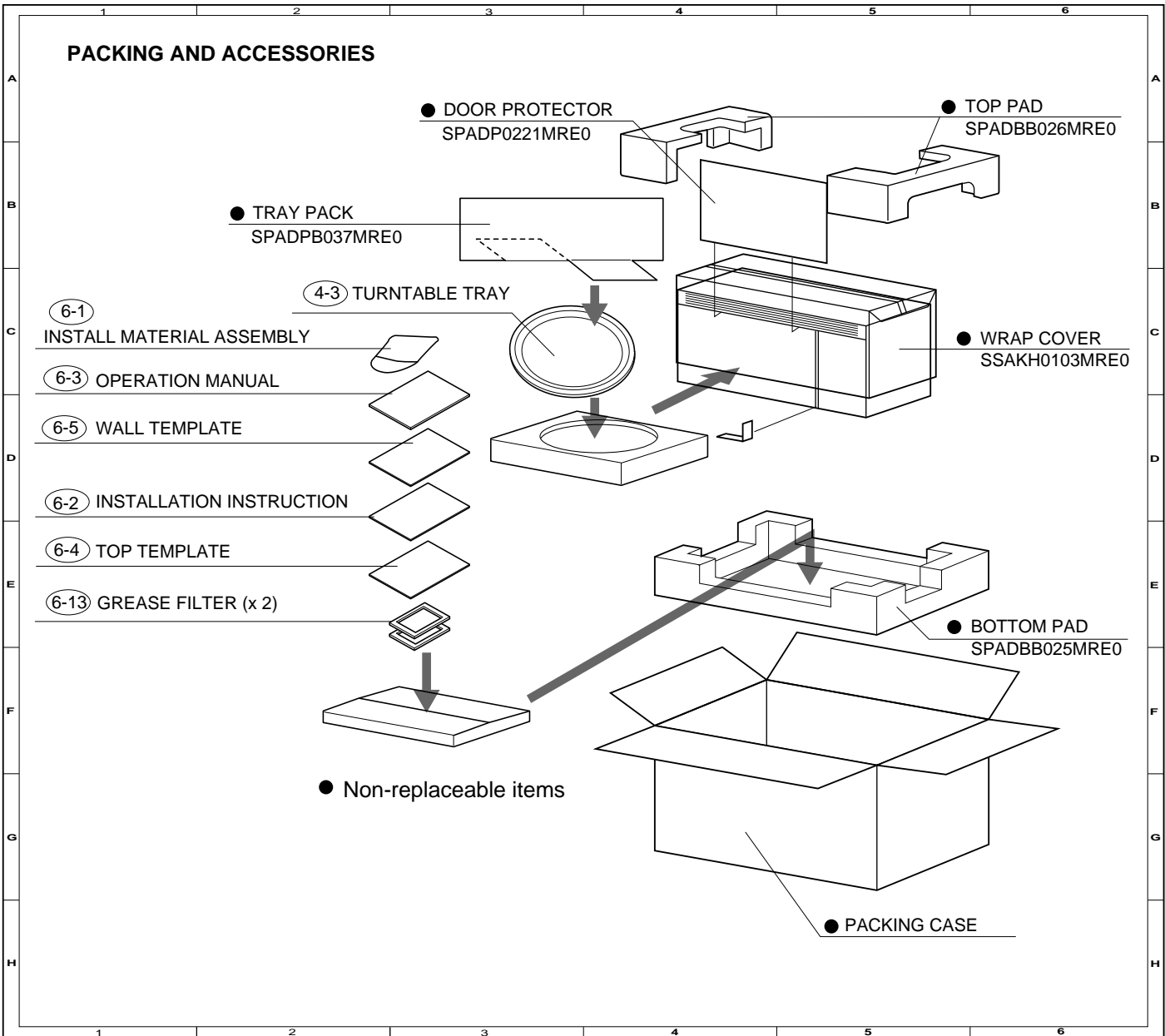

SHARP

COPYRIGHT © 1998 BY SHARP CORPORATION

ALL RIGHTS RESERVED.

No part of this publication may be reproduced, stored in retrieval systems, or transmitted in any form or by any means, electronic, mechanical, photocopying, recording, or otherwise, without prior written permission of the publisher.