

SHARP SERVICE MANUAL

S1651CVP09LX/T

PORTABLE AIR CONDITIONER

MODELS CV-P09LX CV-P10LC

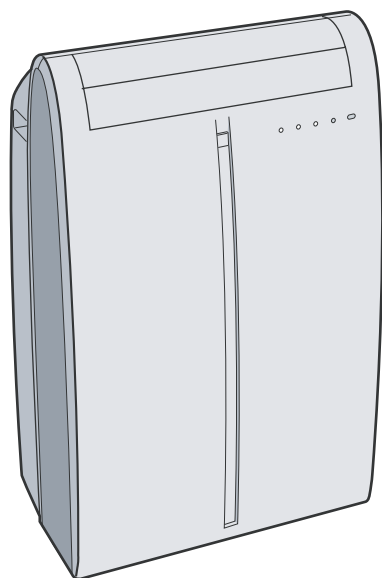

In the interests of user-safety (Required by safety regulations in some countries) the set should be restored to its original condition and only parts identical to those specified should be used.

CONTENTS

CHAPTER 1. PRODUCT SPECIFICATION

- [1] SPECIFICATION..... 1-1
- [2] ELECTRICAL PARTS 1-1
- [3] WIRING DIAGRAM 1-2
- [4] EXTERNAL DIMENSION..... 1-2
- [5] PART NAMES 1-3

CHAPTER 2. DISASSEMBLING PROCEDURE

- [1] PROCEDURE FOR DISASSEMBLY 2-1
- [2] DISASSEMBLING THE CONTROL BOX..... 2-9

CHAPTER 3. EXPLANATION OF CIRCUIT AND OPERATION

- [1] ELECTRONIC CONTROL CIRCUIT DIAGRAM 3-1
- [2] PRINTED WIRING BOARD 3-2
- [3] FUNCTION..... 3-3
- [4] PERFORMANCE CURVES 3-6

CHAPTER 4. ATTENTION WHEN REPAIRING

- [1] HOW TO REPAIR REFRIGERATION4-1
- [2] ELECTRICAL COMPONENT TEST4-3

CHAPTER 5. TROUBLESHOOTING GUIDE

- [1] TROUBLESHOOTING5-1

REPLACEMENT PARTS LIST

Parts marked with "⚠" are important for maintaining the safety of the set. Be sure to replace these parts with specified ones for maintaining the safety and performance of the set.

CHAPTER 1. PRODUCT SPECIFICATION

[1] SPECIFICATION

MODEL		CV-P09LX	CV-P10LC
Cooling Capacity	BTU/h	9000	9500
Moisture Removal	Pint/h	2.5	

Electrical Data

Phase		Single	
Rated frequency	Hz	60	
Rated voltage	V	115	
Rated current	A	9.0	
Rated input	W	1010	
Power factor	%	98	
EER	BTU/Wh	8.9	9.4

Compressor

Type	(Hermetically sealed rotary type)
Model, Motor Output	44R211AE-AJS (805W)

REFRIGERANT SYSTEM

Evaporator	Louver fin, Grooved tube, 7mm, hair pin
Condenser	Louver fin, Grooved tube, 7mm, hair pin
Control O.D. x I.D x Length(mm) (Capillary Tube)	2.7 x 1.4 x 400
Refrigerant Volume R-22 (OZ) (Factory Charge)	12.5

NET DIMENSIONS

Width Height Depth	Inch (mm)	18.5" (470) x 32.3" (820) x 15.1" (383)
Net Weight	Lbs	84

GROSS DIMENSIONS

Width Height Depth	Inch (mm)	22.1" (561) x 35.8" (910) x 18.3" (465)
Gross Weight	Lbs	95

FAN SYSTEM

Indoor side (Evaporator)		Centrifugal fan
Outdoor side (Condenser)		Centrifugal fan
Air Flow rate (Indoor side)	CFM	High
		Med
		Low

OTHERS

Safety devices	Compressor : Overload relay Fan motor (IN/OUT) : Internal thermal fuse / Internal thermal protector
Air filter	Polypropylene net
Power cord length	ft 4.6
Power plug type	NEMA 5-15P

[2] ELECTRICAL PARTS

	CV-P09LX	CV-P10LC
Running capacitor	250V - 60μF	
Fan capacitor (IN/OUT)	250V - 6μF / 250V - 8μF	
Thermistor	10kΩ at 77°F (TH1), 4.431kΩ at 77°F (TH2, TH3)	
Fan motor (IN)	IBH-884-512 (MLB180)	
Fan motor (OUT)	PFU040ZREA/SHP (MLB178)	
Overload relay	MRA99239L-9054 or B380-150B-141E	
Drain motor	ORM-1524K1 (M-A438)	

[3] WIRING DIAGRAM

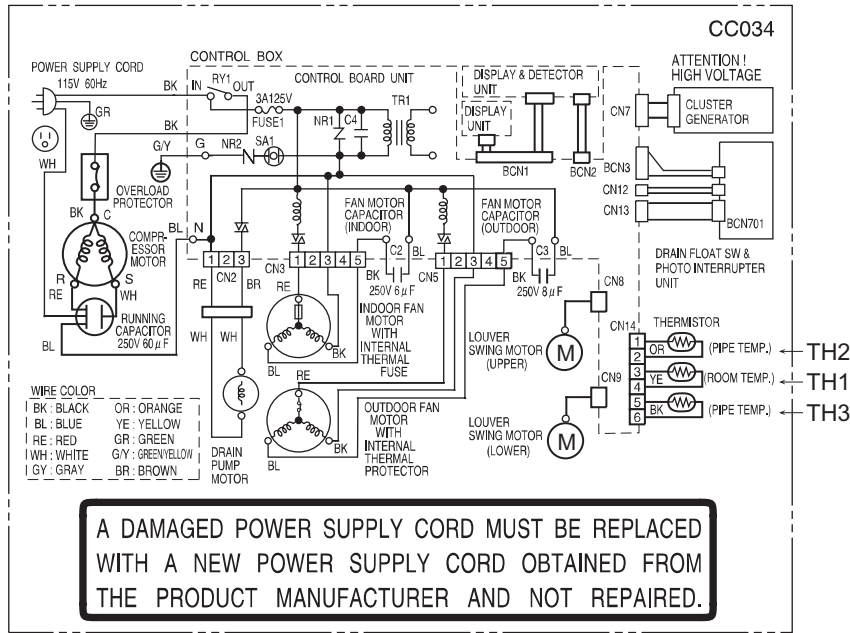

[4] EXTERNAL DIMENSION

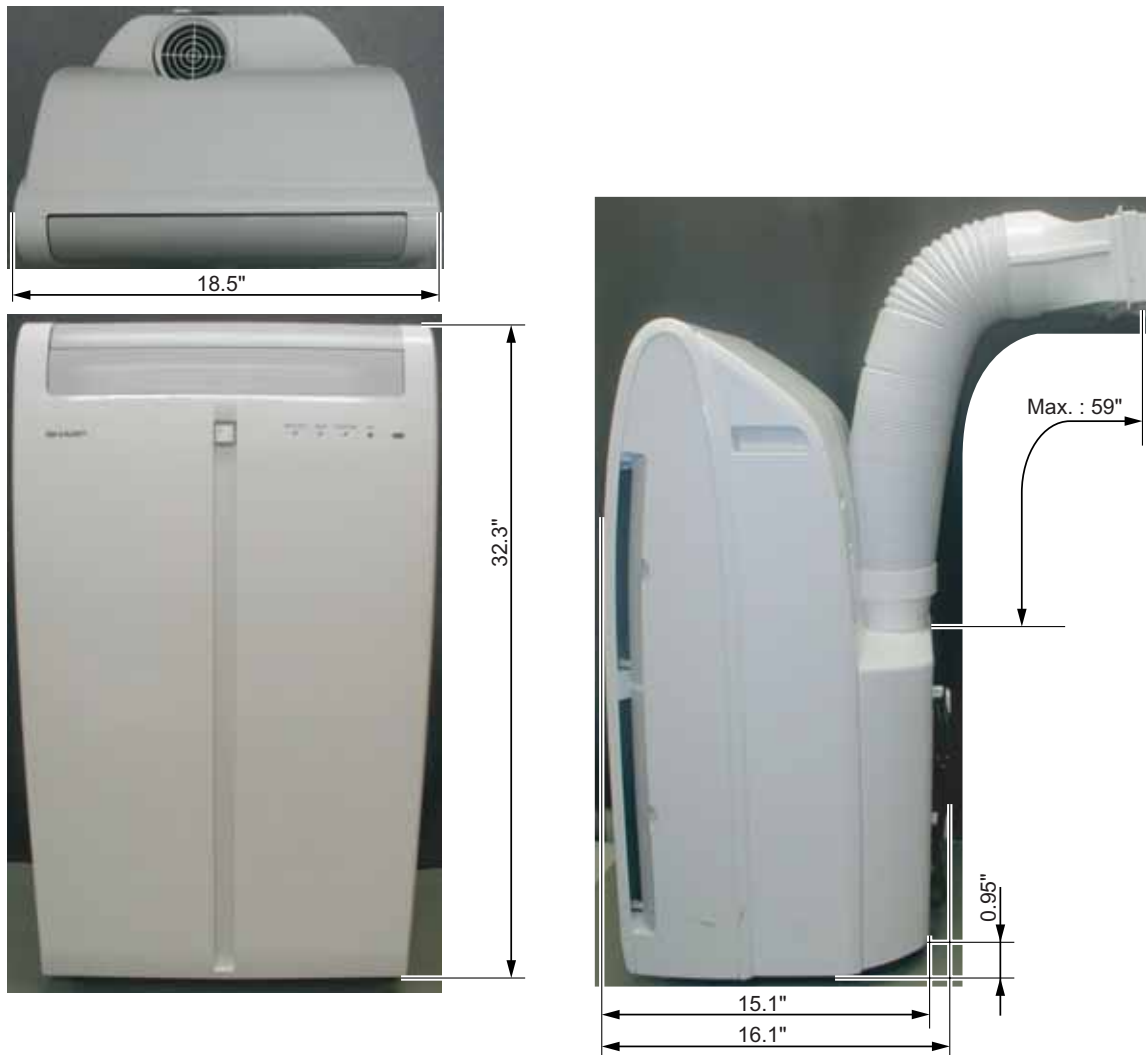

[5] PART NAMES

1. Front view

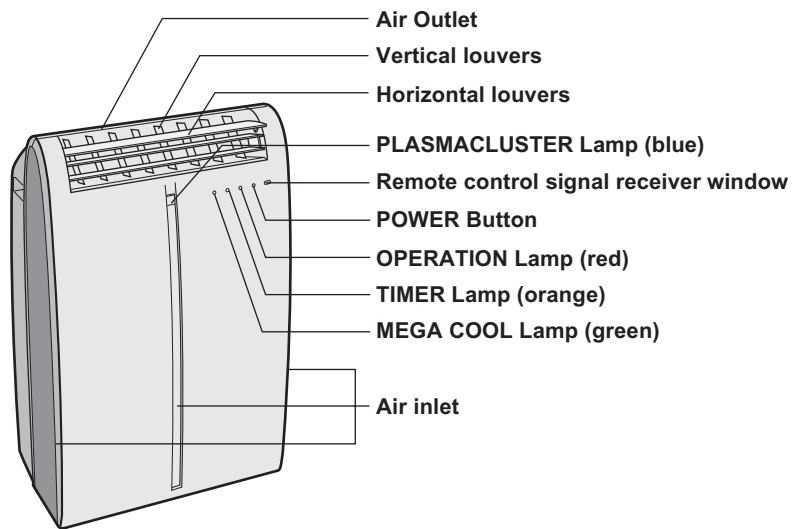

2. Rear view

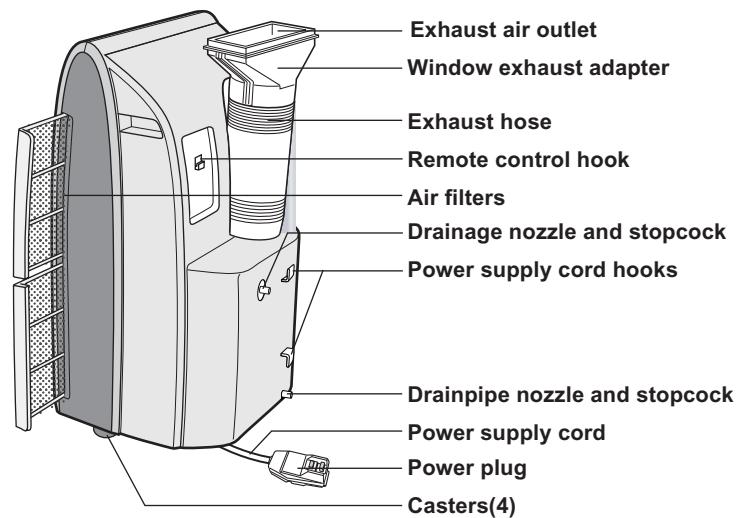

3. Remote control

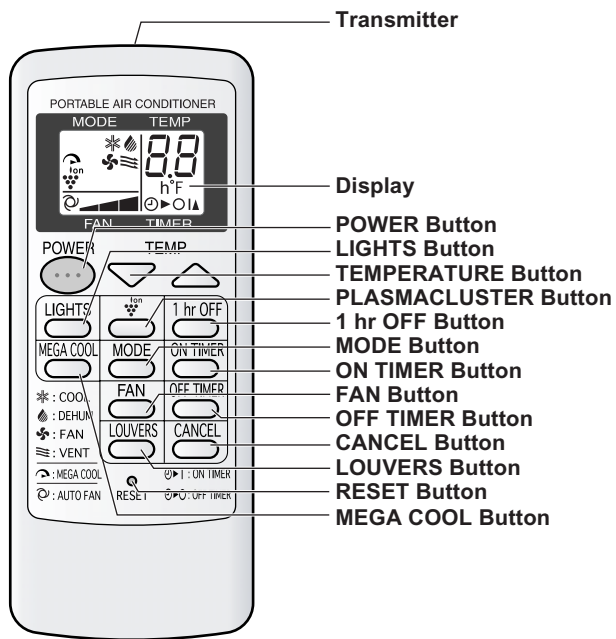

4. Remote control display

MODE SYMBOLS

- ☼ : COOL 🌫 : DEHUMIDIFICATION
- 🌀 : FAN ≡ : VENTILATION

MEGA COOL SYMBOL

PLASMACLUSTER SYMBOL

FAN SPEED SYMBOLS

- 🌀 : AUTO 📊 : Manual setting

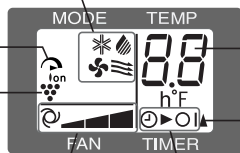

TEMPERATURE AND TIMER COUNT DOWN INDICATOR

TRANSMITTING SYMBOL

ON TIMER / OFF TIMER SYMBOL

CHAPTER 2. DISASSEMBLING PROCEDURE

[1] PROCEDURE FOR DISASSEMBLY

"ACTUAL UNITS MAY VARY SLIGHTLY FROM THOSE PICTURES BELOW"

CAUTION: • DISCONNECT THE PORTABLE TYPE ROOM AIR CONDITIONER FROM THE POWER SUPPLY BEFORE ANY SERVICE.

- DISCONNECT THE EXHAUST HOSE FROM THE UNIT BEFORE ANY SERVICE.(SEE OPERATION MANUAL "E-16")
- DRAINAGE SHOULD BE PERFORMED BEFORE ANY SERVICE.

(SEE "WHENEVER THE UNIT IS MOVED" OF OPERATION MANUAL "E-29")

1. Unscrew 2 screws holding the front panel on lower both ends.



2. Remove two air filters.



3. Open horizontal louvers, as shown in below figure.



4. Unhook 6 hooks of the front panel which is at both sides in an order from the lower position using flathead screw driver. <6 parts>



1) Insert flathead screw driver into the position shown in below figure. Then gently pry the driver to the arrow mark direction, to unhook the lower hooks (both sides).



2) Insert flathead screw driver into the position shown in below figure. Then gently pry the driver to the arrow mark direction, to unhook the middle hooks (both sides).



3) Insert flathead screw driver into the position shown in below figure. Then gently pry the driver to the arrow mark direction, to unhook the upper hooks (both sides).

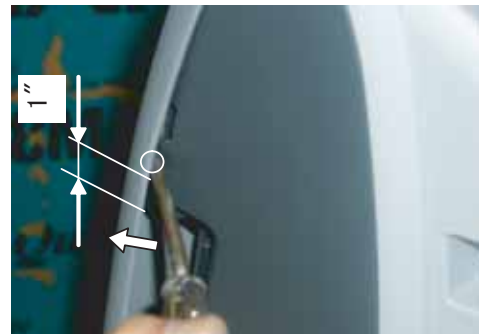

5. Push down the orifice (at position of illustration), as shown in below figure, to unhook 2 hooks of front panel.

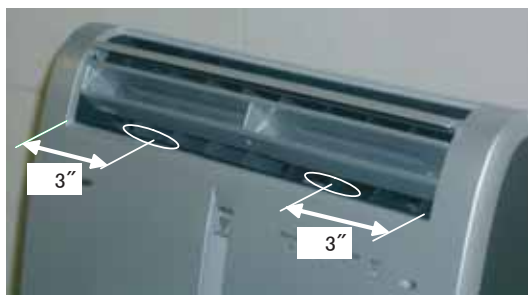

6. Remove the front panel by pulling it at the lower corner toward you as shown in a figure, and next lift it up and pull it toward you.



7. Unscrew 6 screws holding the side panel L and R. Remove side panel L and R.



8. Remove the stopcock from the drainpipe nozzle.



* Drain stopcock replacement

- Please check that the stopcock is fully inserted into the drainage nozzle and drainpipe nozzle when operating at cooling mode, and after drainage.
- Applying small amount of soapsuds to the stopcock will help it make easier, if it is difficult to fully insert the stopcock.

9. Unscrew 12 screws holding the cabinet.

6 screws are on each sides.

6 screws are on back side of unit.



CVP09LX

10.Remove the cabinet by lifting it up and pulling toward you as shown in below figure.



11. Unscrew 4 screws holding the control box cover.



12.Remove the control box cover, as shown in below figure.

CAUTION: DISCHARGE THE FAN MOTOR CAPACITOR AND RUNNING CAPACITOR BEFORE TOUCHING THESE CAPACITORS OR OTHER COMPONENTS OR WIRING.



13.Unscrew 2 screws holding the float switch ass'y.



Then move the float switch a little from bulkhead L.

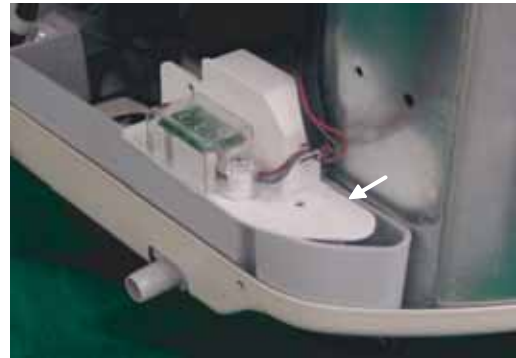

14.Unscrew 6 screws holding the bulkhead L.
Remove the wire from wire holder.(2 parts)



Then remove the bulkhead L by pulling it toward the arrow mark in below figure and next lift it up toward you.



15. Unscrew 7 screws holding the stay angle L.
Remove the stay angle L.

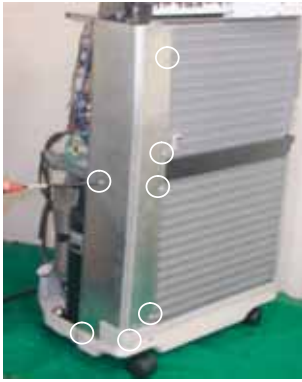

16. Unscrew 3 screws holding the led guide.
Remove the led guide.



17. Disconnect two louver motor connectors.
CAUTION: CONNECT THE CONNECTOR OF LOUVER MOTOR CORRECTLY WHEN RE-ASSEMBLYING.
White connector : Upper louver motor
Black connector : Lower louver motor



18. Unscrew 2 screws holding the cluster holder.
Remove the cluster holder.



19. Remove the plasmacluster unit and cluster cover.
Disconnect the connector of plasmacluster unit.



20. Unscrew 5 screws holding the top duct
Remove the top duct



21. Cut the fixing band holding the wire and tape. Then remove the tape.
CAUTION: KEEP THE TAPE IN CASE OF RE-ASSEMBLYING.



CVP09LX

22. Cut the fixing band holding the wires.(7 parts)

Disconnect 8 connectors.

CAUTION: CONNECT THE CONNECTORS OF FAN MOTOR ETC. CORRECTLY WHEN RE-ASSEMBLYING.

- CN6 : OUTDOOR FAN MOTOR(BLACK AND SMALL)
- CN4 : INDOOR FAN MOTOR(WHITE AND SMALL)
- CN3 : INDOOR FAN MOTOR(WHITE AND LARGE)
- CN5 : OUTDOOR FAN MOTOR(BLACK AND LARGE)
- CN13 : LEAD WIRE FOR FLOAT SWITCH ASS'Y(4P)



23. Cut the fixing band holding the wires.(1 part)



24. Cut the fixing band holding the wire and tape.

Then remove the tape.

CAUTION: KEEP THE TAPE IN CASE OF RE-ASSEMBLYING.

Then cut the fixing band holding the wires.

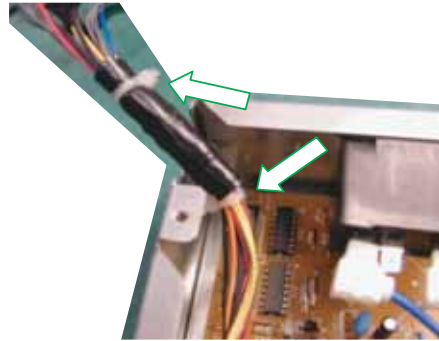

25. Disconnect the micro switch connector.

*Lower micro switch only.



26. Unscrew 3 screws holding the wire holders.



27. Remove wiring connectors of the compressor cord by using long-nose pliers.(3 parts)



CAUTION: DISCHARGE THE FAN MOTOR CAPACITOR AND RUNNING CAPACITOR BEFORE TOUCHING THESE CAPACITORS OR OTHER COMPONENTS OR WIRING.

28. Unscrew 2 screws holding the control box.
Remove the control box from the unit.



29. Unscrew 6 screws holding the casing cover.
Remove the casing cover from the unit.



30. Unscrew 4 screws holding the orifice.
Remove the orifice from the unit.



Then turn the band to the direction, as shown in below figure.
CAUTION: RETURN THE BAND TO THE ORIGINAL DIRECTION WHEN RE-ASSEMBLYING.



31. Move the band to the direction shown in below figure (approx. 11/16").

Then removed the drain hose B.



32. Unscrew the screw holding the lead wire.



33. Turn the band, as shown in below figure.

CAUTION: RETURN THE BAND TO THE ORIGINAL DIRECTION WHEN RE-ASSEMBLYING.

Move the band to the direction of the arrow (approx. 11/16"), and removed the drain hose A.

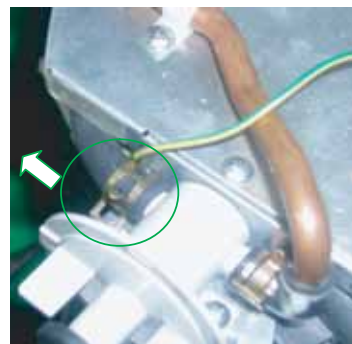

CVP09LX

34. Unscrew 4 screws holding the half plate.

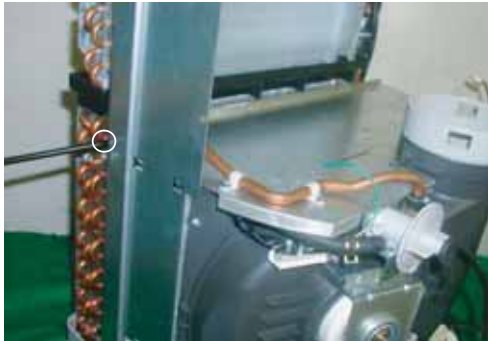

Then remove the half plate by lifting it up and pulling toward you as shown in below figure.



35. Unscrew 6 screws holding the out casing.
Remove the out casing from the unit.



36. Unscrew 6 screws holding the stay angle R.
Remove the stay angle R from the unit.



37. Unscrew 3 screws holding the drain pump ass'y.
Remove the drain pump ass'y from the unit.



38. Unfasten and remove the nut holding the terminal cover at the top of compressor.
Then remove the wiring connector of the compressor cord.



39. Unscrew the screw holding the centrifugal fan.
Remove the centrifugal fan.

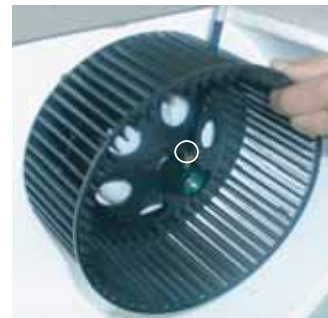

40. Unscrew 4 screws holding the motor cover and wire holder.

Remove the motor cover.

Then remove the fan motor.



41. Unscrew the screw holding the centrifugal fan.



42. Unscrew 5 screws holding the motor cover and wire holder.

Remove the motor cover.

Then remove the fan motor.

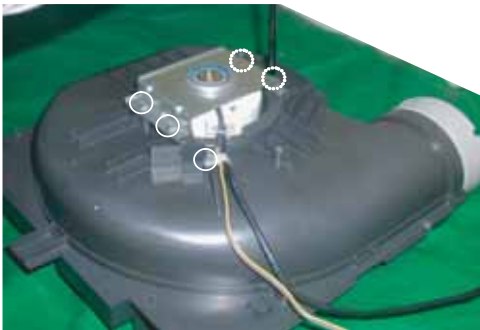

[2] DISASSEMBLING THE CONTROL BOX

CAUTION: DISCHARGE THE FAN MOTOR CAPACITOR AND RUNNING CAPACITOR BEFORE TOUCHING THESE CAPACITORS OR OTHER COMPONENTS OR WIRING.

1. Cut fixing bands holding the wires.(2 parts)



2. Remove 2 P.W.B.

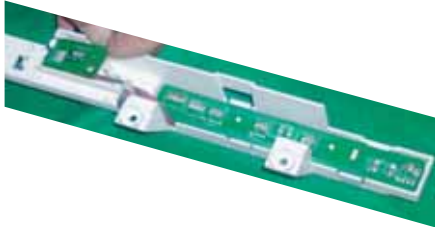

3. Cut fixing bands holding the wires.(2 parts)

Disconnect 6 connectors.

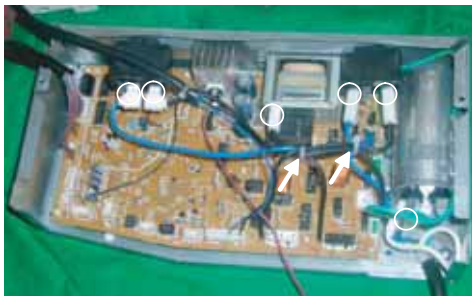

4. Unscrew 5 screws holding fan motor capacitor, transformer and lead wire (earth).

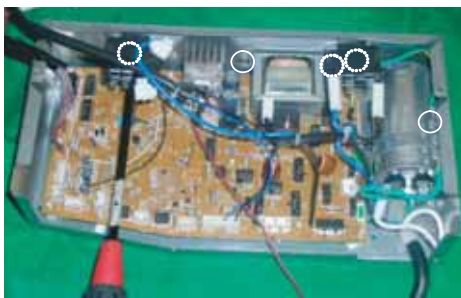

5. Remove the control board by unhooking 3 spacers.

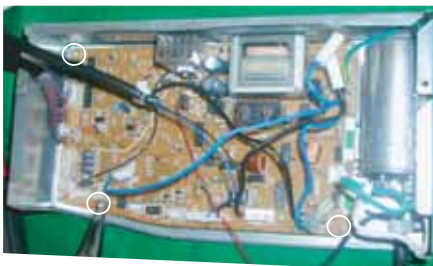

[2] PRINTED WIRING BOARD

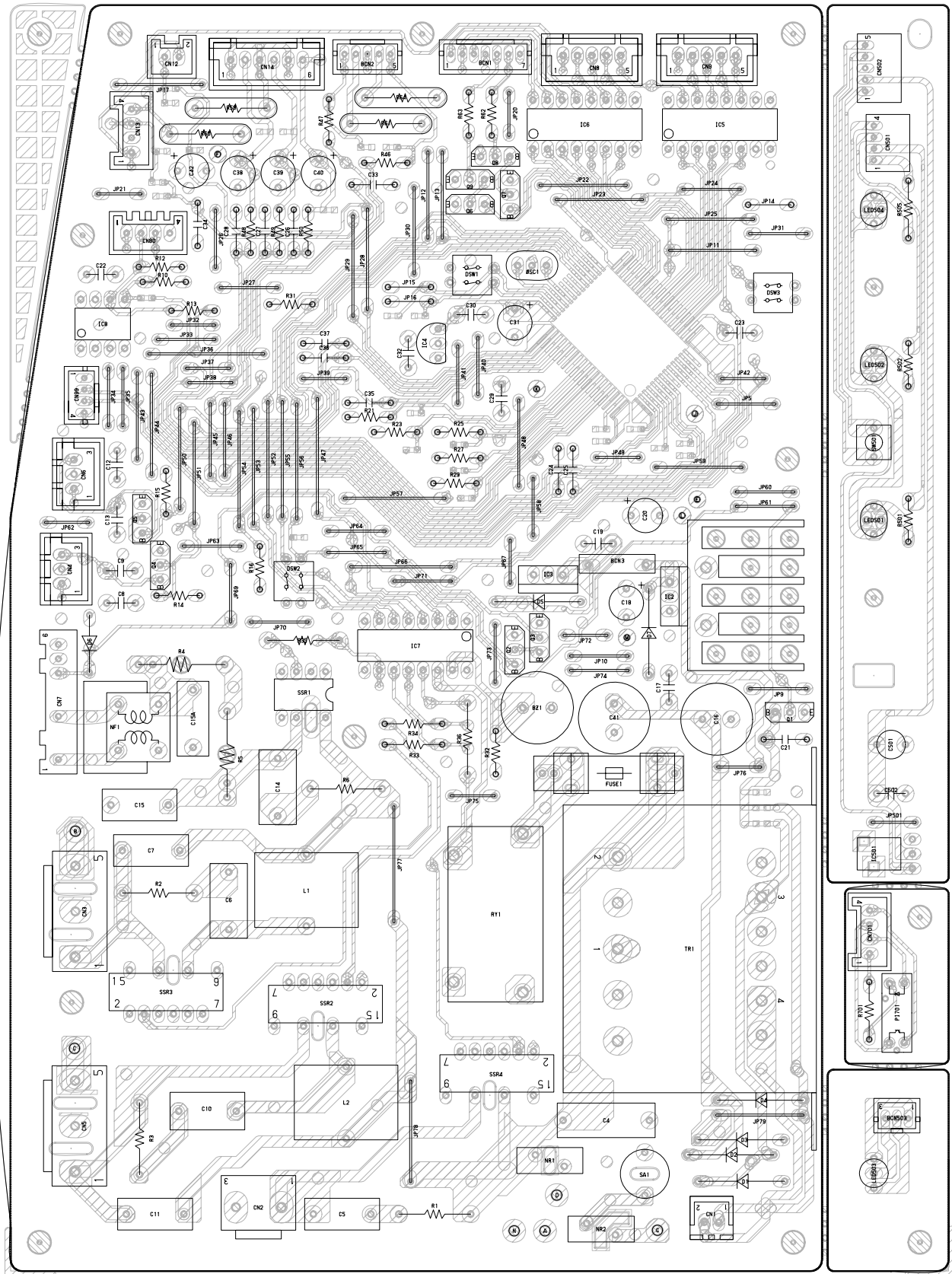

[3] FUNCTION

1. Cool Operation

In the "COOL" mode, the thermostat circuit is controlled by 3 thermostat lines(C1-C3).

When the difference between Room Temperature and Preset Temperature is in [2]-[4] area, compressor is driving or starts driving. If [1] area is detected, compressor will stop. And indoor fan speed is set as following speed.

Room Temperature—Preset Temperature

C1	0.9 / 2.7°F
C2	0 / 0.9°F
C3	-2.7 / -0.9°F

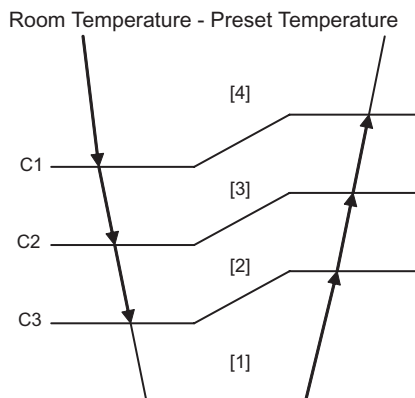

Indoor fan speed

Area	Customer Setting			
	L	M	H	AUTO
[4]	CL	CM	CH	CAH
[3]				CM
[2]				CAL
[1]				

2. Dehumidification Operation

In the "Dehumidification" Mode, compressor is controlled by room temperature. If it goes over D1 line and gets into the area [3], or if it lowers than D2 line and gets into the area [1], compressor will stop.

If the evaporator temperature is lower than D3 line, indoor fan speed will be DH and if the evaporator temperature is higher than D3 line, indoor fan speed will be DL when the room temperature is in area [2].

Room Temperature

D1	111.2 / 113.0°F
D2	50.0 / 51.8°F

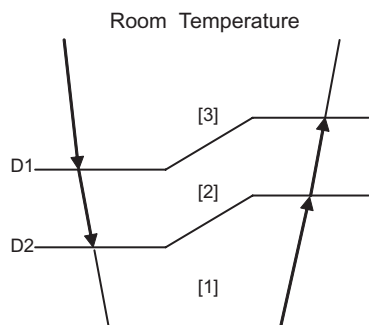

Indoor fan speed

Evaporator Temperature	Customer Setting	
	AUTO	
Lower than D3	DH	
Higher than D3	DL	

D3	53.6 / 60.8°F
----	---------------

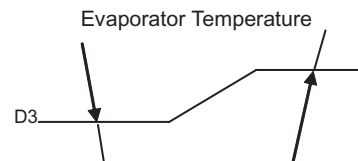

3. Fan Operation

In the "Fan" mode, compressor and outdoor fan doesn't operate. Indoor fan motor operates as follows.

Indoor fan speed

Customer Setting		
L	M	H
AL	AM	AH

4. Ventilating Operation

In the "Ventilation" mode, compressor and indoor fan doesn't operate. Outdoor fan motor operates as follows.

Indoor fan speed

Customer Setting		
L	M	H
600[rpm]	900[rpm]	1200[rpm]

5. Indoor Fan Speed

Fan speeds are given by the indoor fan motor, "DL"~"AH" which are available in the following operation mode.

In the "COOL" or "DRY" mode, indoor fan speed is different by condenser temperature.

Fan Speed	Setting		[rpm]	
DEHUM	DL	-	AUTO	400 ~ 500
	DH	-	AUTO	500 ~ 600
COOL	CL	COOL SOFT	-	420 ~ 520
	CAL	-	AUTO	500 ~ 600
	WET	-	-	570 ~ 670
	CM	COOL LOW	AUTO	570 ~ 670
	CAH	-	AUTO	650 ~ 750
FAN ONLY	CH	COOL HIGH	-	720 ~ 820
	AL	FAN ONLY	-	520
	AM	FAN ONLY	-	640
	AH	FAN ONLY	-	750

6. Overheating protection system

If the condenser temperature goes over 136.4°F during the cooling or dry operation, outdoor fan speed will rise to prevent the overloading of the compressor and restrain the rise in high pressure, and If it lowers than 134.6°F, outdoor fan speed will return.

If the condenser temperature goes over 158.0°F during the cooling or dry operation, compressor will stop and if it lowers than 149.0°F, compressor will restart after 3 minutes.

7. Freeze preventive

When the indoor pipe temperature falls below 32.0°F during cool operation or dry operation, the compressor is turned off. And if the indoor pipe temperature rises exceeds 39.2°F after 3 minutes, the compressor will restart.

8. Timer

8.1. OFF TIMER

Set the OFF-TIMER.

The unit will turn off automatically according to your setting. Timer duration can be set by 0.5 hours to maximum 12 hours. Up to 9.5 hours, you can set by 0.5hours increments and from 10 to 12 hours, by 1 hour increment.

8.2. ON TIMER

Set the ON-TIMER.

The unit will turn on automatically according to your setting. Timer duration can be set by 0.5 hours to maximum 12 hours. Up to 9.5 hours, you can set by 0.5hours increments and from 10 to 12 hours, by 1 hour increment.

8.3. ONE-HOUR TIMER

When ONE-HOUR timer is set, the unit turns off automatically after one hour. The one hour timer operation has priority over other time operation, such as the TIMER ON and TIMER OFF. If the ONE-HOUR TIMER button is pressed again during operation, the unit will operate additionally for another one hour.

11. Diagnostic program

When indoor fan motor is out of order or compressor lock or abnormal water level occurs, the compressor, indoor fan motor, outdoor fan motor, and louver are all stopped and the operation LED(red) turns on or off synchronously with the timing of the timer LED. When the thermistor for room temperature or pipe temperature is open or short state, the operation LED turns on or off synchronously with the timing of the timer LED by pushing continuously for more than 5 seconds "AUX." button during suspension of operation.

Timer LED		<p>The diagram shows a square wave for the Timer LED. The ON state has a pulse width of 1 second, and the OFF state has a pulse width of 4 seconds. The cycle repeats.</p>
Operation LED	Indoor fan motor	<p>The diagram shows a square wave for the Indoor fan motor. The ON state has a pulse width of 1 second, and the OFF state has a pulse width of 4 seconds. The cycle repeats.</p>
	Outdoor fan motor	<p>The diagram shows a square wave for the Outdoor fan motor. The ON state has a pulse width of 1 second, and the OFF state has a pulse width of 4 seconds. The cycle repeats.</p>
	Thermistor short state	<p>The diagram shows a square wave for the Thermistor short state. The ON state has a pulse width of 1 second, and the OFF state has a pulse width of 4 seconds. The cycle repeats.</p>
	Thermistor open state	<p>The diagram shows a square wave for the Thermistor open state. The ON state has a pulse width of 1 second, and the OFF state has a pulse width of 4 seconds. The cycle repeats.</p>

12. Drain Pump

When drainage is accumulated the float switch becomes close condition and the microcomputer detects this for 1 minute and cause to operate drain pump. If it has passed for 3 minutes since the microcomputer detects an error by photo interrupter circuit, Compressor will stop and ALL LED will blink.

9. POWER Button

9.1. Test Run

If the "POWER" button on the unit is pressed for 5 seconds or more during operation, cool test operation starts. The operation LED (red) flickers during test run. Continuous compressor on operation is performed.

During Test-Run mode, pump is always ON.

9.2. Aux Operation

If the "POWER" button on the unit is pressed during operation OFF, cooling operation starts.

Then setting Temperature will be is automatically set.

During Aux mode, pump will be ON for 1 minute since start.

10. Test mode

Keep pushing the "POWER." buttons and supply the power, the system will go to the test mode. In this mode, the output of operation is switched by pushing the "POWER." button in the unit or the "OI" button in the remote controller. Normal outputs are shown in "Self Check Mode Table"

13. Plasmacluster

Whenever an indoor machine receives the signal of the plasma cluster from remote control during air conditioner operation, the operation mode regarding at the plasmacluster changes in the order of the following.

Clean mode → OFF

14. SELF-CHECK MODE

STEP	LED								P.I. Power Supply	Plasmacluster	Pump	Compressor	Eva Fan	Cond Fan	Louver (Upper Side)				Louver (Lower Side)							
	RED		YELLOW		GREEN		BLUE								A	B	C	D	A	B	C	D				
0	Room Temp		Eva Temp		Cond Temp		Test Input		X	X	X	X	X	X	X	X	X	X	X	X	X	X	X	X	X	
	44.6~107.6°F	O	28.4~113.0°F	O	28.4~113.0°F	O	P37 = H	O																		~44.6°F, 107.6°F~
1	Power On Start Select		Function Select A		Function Select B		X		X	X	O	X	X	X	O	X	O	X	O	X	O	X	O	X	O	X
	P44 = H	O	P45 = H	O	P46 = H	O																				
	P44 = L	X	P45 = L	X	P46 = L	X																				
2	E2PROM		Wireless		Cond Fan RPM Input		O		X	O	X	X	X	X	Speed 1	X	O	X	O	X	O	X	O	X	O	X
	OK	O	P40 = H	O	OK	O																				
	NG	X	P40 = L	X	NG	X																				
3	Photo Interrupter		Float SW (L)		Eva Fan RPM Input		X		O	O	O	X	CL	Speed 2	OPEN				X	X	X	X				
	P64 = H	X	P63 = H	O	OK	O																				
	P64 = L	O	P63 = L	X	NG	X																				
4	Photo Interrupter		Float SW (L)		Sweat		Auto Restart Select		X	X	X	X	CM	Speed 3	OPEN				OPEN							
	P64 = H	X	P63 = H	O	P41 = H	O	P34 = H	O																		
	P64 = L	O	P63 = L	X	P41 = L	X	P34 = L	X																		
5	X		X		O		X		X	X	O	O	CH	Speed 4	X	X	X	X	X	X	X	X	X	X	X	X
6	X		X		X		O		X	X	X	X	AL	VL	X	X	X	X	X	X	X	X	X	X	X	X
7	X		O		O		O		X	X	O	X	AM	VM	X	X	X	X	X	X	X	X	X	X	X	X
8	X		O		O		O		X	X	X	X	AH	VH	X	X	X	X	X	X	X	X	X	X	X	X
9	X		O		O		O		X	X	O	X	Mega	VH	X	X	X	X	X	X	X	X	X	X	X	X
10	X		O		O		O		X	X	X	X	X	X	X	X	X	X	X	X	X	X	X	X	X	CLOSE
11	X		O		O		O		X	X	O	X	X	X	X	X	X	X	X	X	X	X	X	X	X	CLOSE

[4] PERFORMANCE CURVES

NOTE: 1) Use this data only as a guide to check the running condition.

2) The running conditions of this data is as follows.

Remote control setting High cool, 64°F

Drain pump OFF

Exhaust hose Shortest

3) This data will be changed by operation conditions such as: a drain pump operation or an exhaust hose configuration.

Especially, pump operation will decrease the line current and the power input value significantly.

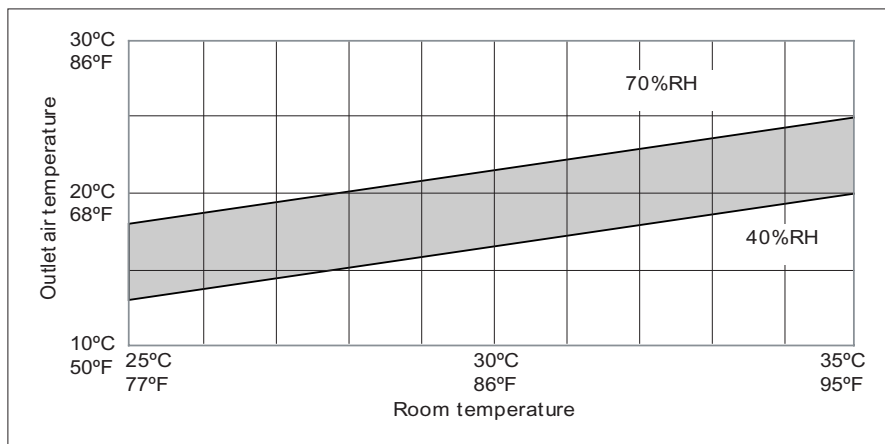
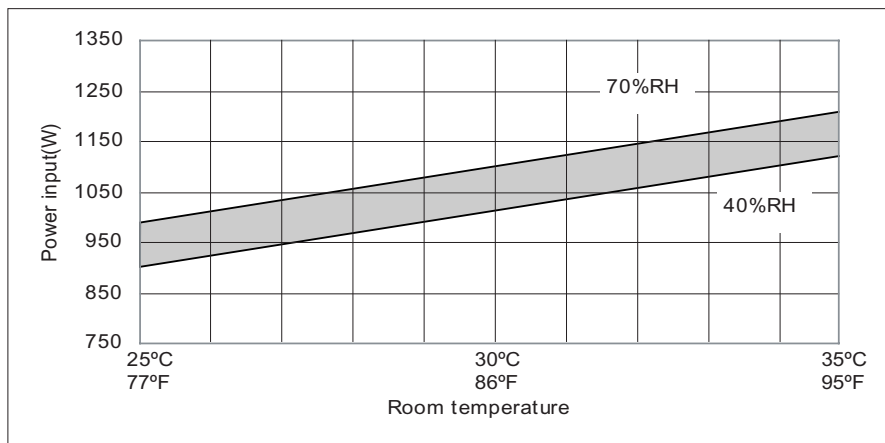
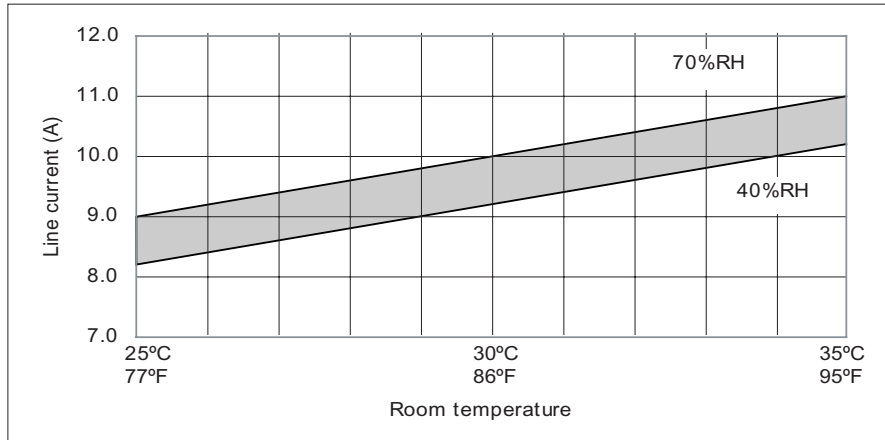

CHAPTER 4. ATTENTION WHEN REPAIRING

[1] HOW TO REPAIR REFRIGERATION

Before sealed system work can be performed a refrigerant recovery EPA and LOCALLY approved certification is required, additionally, EPA and LOCALLY approved refrigerant recovery equipment is required.

1. Sealed system repair

Sealed system repairs should be properly diagnosed before entering into a repair of the system.

It is important to follow proper procedures when doing a system repair for safety reasons and that the repair will result in a restoration of the system to proper factory standards.

2. Safety reminders

- 1) Do not heat any system component with an open flame for any reason.
- 2) Do not solder until you are sure that all refrigerant has been removed from the system.
- 3) Do not heat the charging cylinder with an open flame. Use warm water only and do not exceed 125°F (not too hot to keep your hand in.)
- 4) Do not over fill any charging cylinders, as they could explode when over filled.
- 5) Use proper wrenches.
- 6) Use safety goggles when working with refrigerants.
- 7) Keep a fire extinguisher within easy reach.
- 8) Watch flame direction when soldering so as not to burn clothing, wiring or other components.
- 9) Solder in a well ventilated area. If a high concentration of freon is present, an open flame will create phosgene gas which can be harmful.

3. Proper soldering

Joint clearances should be maintained so that the brazing alloy will flow between the closely mated surfaces rather than forming large fillets.

This films make the strongest joints, capillary attraction also work best with close tolerance.

The best clearance is between 0.01" to 0.03", the amount of lap will be approximately 3/8" depending on the swaging tool used.

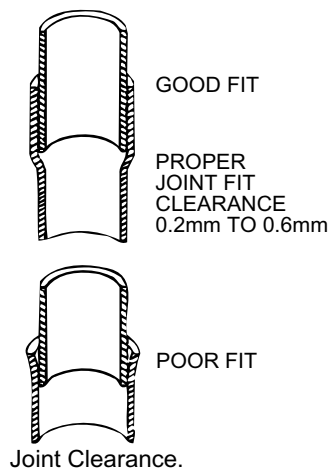

4. Cleaning tubing

To make a sound, leak tight joint, the brazing alloy when raised to brazing temperature, must wet and flow freely over the entire surface of the tubing in the joint area.

To assure this, the tubing surfaces must be free of all dirt, grease, oil and oxides otherwise the alloy will not wet and flow properly over any surface with these elements present. Cleaning can be done with an abrasive cloth or steel wool. Never blow into the tubing because this will introduce a lot of moisture into the system. Open tubing joints should be covered if exposed for long periods of time.

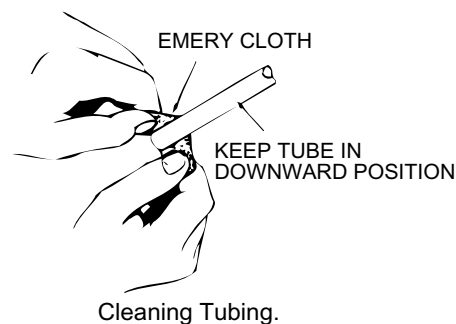

5. Proper fluxing

Flux is necessary when using silver solder; it is not required when using silfos on copper to copper joints.

To do a good job the flux should cover the tube surface completely. Be careful not to introduce any flux inside the tubing.

Fluxing should be done after the tubing is mated together and just before brazing is done. Do not allow it to dry out.

When brazing, the flux should become entirely liquid and clear, like water. The temperature will be at 1100°F and only a little more heat will allow the alloy to flow freely into the joint.

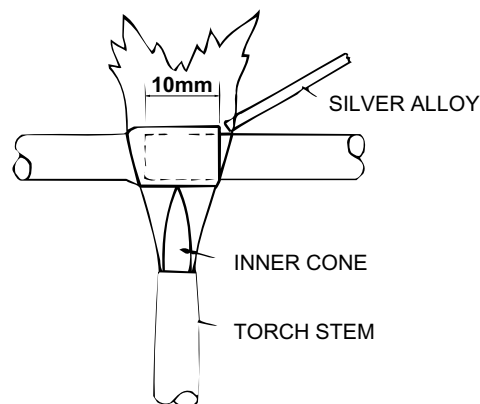

6. Heating the tubing

Direct the torch flame so that the larger tube receives most of the heat. Silver solder flows at 1200°F and silfos flows at 1300°F.

Heat all around the tubing.

The flame is composed of two cones, a smaller inner cone (pale blue) in calor and a much larger outer cone. The hottest part of the flame is at the tip of the inner cone. The flame should be directed at the joint with the tip of the cone just touching the surface of the tubing.

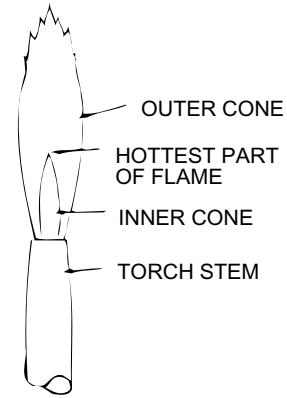

Composition of Torch Flame.

7. Dehydrating sealed system

Many servicers feel that since air conditioners run with evaporator temperatures above 33°F, moisture will not present a problem. Nothing is further from the truth. Oxygen in moisture plus the heat produced during compression will react with the refrigerant oil to produce harmful acids in the system which will break down motor winding insulation, create sludge and pit component parts, reducing efficiency of the air conditioner and shortening the life of compressors.

There it becomes mandatory that good dehydrating practices be adhered to at all times.

Proper hook up procedures as shown in Figure 5 must be used in order to pull and good vacuum from the system.

The use of a good vacuum pump is very important so that the boiling point of any water in the system will be lowered to a point where it will vaporize and be expelled from the system in the form of vapor.

7.1. Type of evacuation methods

1. **Piston Type Compressor** No good.

System parts must be above 110°F.

2. **Rotary Vacuum Pump** Disadvantages.

Low CFMC. 4 oil gets dirty.

3. **Single State Vacuum Pump** will not clean oil.

Oil must be changed often.

4. **Two Stage Vacuum Pump** will reach 50 microns.

First stage is below atmospheric pressure.

Moisture is removed into second stage which works up to atmospheric pressure thus keeping oil clean.

Manometer cannot be read to 1/2 mm. Micron gauge reads from 25,400 microns to 0.

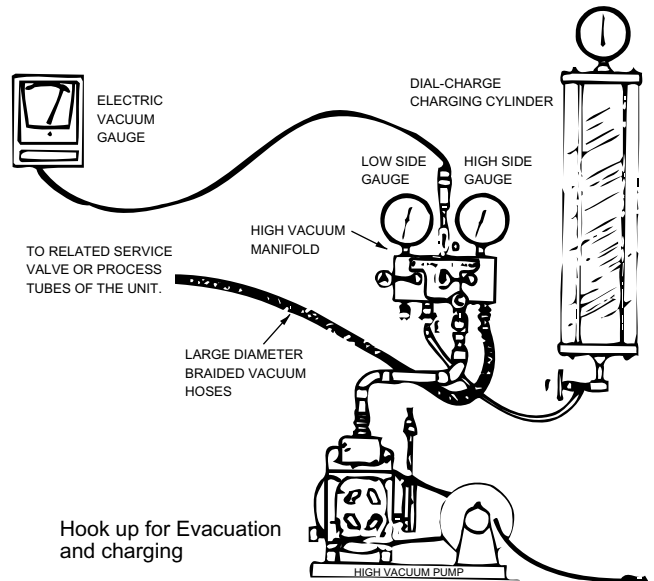

Hook up for Evacuation and charging

It becomes clear that good equipment and maintained properly must be used in order to remove air and moisture from the system.

When a vacuum of 1,000 to 500 microns is reached, block off the vacuum pump from the system.

This is done by closing the value between the pump and system. If the micron gauge does not increase above 1,000, the system is free of moisture and no leak exists. If the micron gauge increases to higher levels moisture or a leak exists.

8. Leaks

Several methods are used to detect leaks in systems.

- **Electronic Leak Detectors** are very sensitive and are able to detect leaks down to 1/2 ounce per year.

A good electronic leak detector is generally far better in locating very small leaks.

- **Halide Torch** be sure the room is free from refrigerant vapours. Watch the flame for the slightest change in color.

A very faint green indicates a small leak. The flame will be unmistakably changed to green or purple when large leaks are encountered. To simplify leak detection pressurize the system to approximately 75 lbs.

Some leaks can be located by a visual inspection of the system components and solder joints and if oil is found at any given location it generally is a sign that a leak exists at that point due to the fact that flame does carry oil with it travels through the system.

- **Soap Bubbles**

Liquid detergents can sometimes assist in finding small leaks by brushing detergent on the suspect area and watching for bubbles. Before applying detergent be sure that the system is pressurized.

Tap line devices are permissible for diagnosis only they are not suitable when evacuating the system. After the diagnosis has been made they must be removed so that the system will be restored to a hermetically sealed condition.

[2] ELECTRICAL COMPONENT TEST

RUNNING CAPACITOR AND FAN CAPACITOR

NOTE: DISCHARGE THE RUNNING CAPACITOR AND FAN CAPACITOR BEFORE TOUCHING CAPACITOR OR WIRING.

- 1) Discharge capacitor by shorting terminals.
- 2) Take the wires off the capacitor terminals.
- 3) Set the selector switch of a volt-ohm-meter (or a tester) on the resistance range.
- 4) Connect the probes to the capacitor terminals and watch the indicator swing.

The indicator does not swing at all Open.

The indicator swings but does not return Shorted.

The indicator swings, then returns a moment later Good.

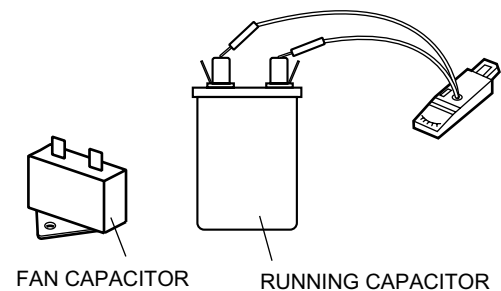

1. Insulation test

Check the resistance between the terminals and case.

Reading must be more than 10MΩ at DC 500V.

2. Overload relay

Check continuity between terminals with volt-ohm-meter.

3. Insulation test

Check resistance between terminals and the relay case.

Reading must be more than 10MΩ at DC 500V.

4. Compressor

- 1) Take the wires off compressor terminals.
- 2) Set selector switch of volt-ohm-meter on the resistance range.
- 3) Put the probes on the terminals of the compressor and check continuity between each terminal.

5. Insulation test

Check the resistance between the terminals and the copper tube.

Reading must be more than 10MΩ at DC 500V.

CHAPTER 5. TROUBLESHOOTING GUIDE

[1] TROUBLESHOOTING

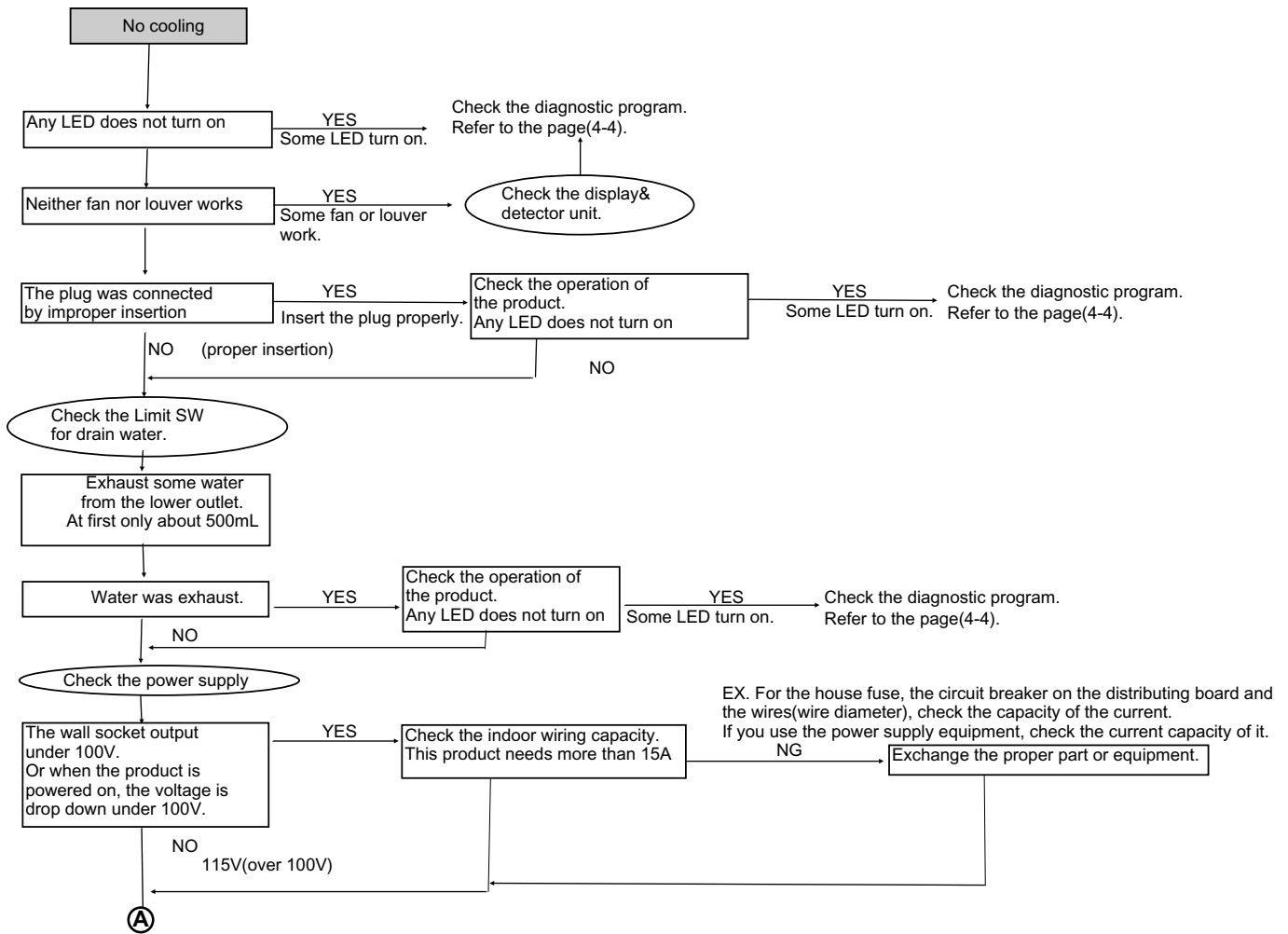

Checking for LCDI

Pull the LCDI out from the wall socket. And remove the LCDI from product.

Push the reset button on the LCDI.(If the LCDI is tripped itself before, you must push the reset button to bring back the common state.)

Put the LCDI into the wall socket.(Check the output of the power supply cord) → under 100V NG(out of order)
115V(over 100V)

Push the test button on the LCDI.
(If the LCDI is tripped itself by this action, the LCDI is working normally.) → The LCDI did NOT trip. The output is 115V(over 100V.) NG(out of order)
115V-->0V

Push the reset button on the LCDI to bring back the common state. → The LCDI output voltage is 0V . NG(out of order)
0V-->115V(or receptacle output voltage)
While the reset button is pushed ,the power supply cord output is 0V.
When you release the button, the output will be 115V.

OK

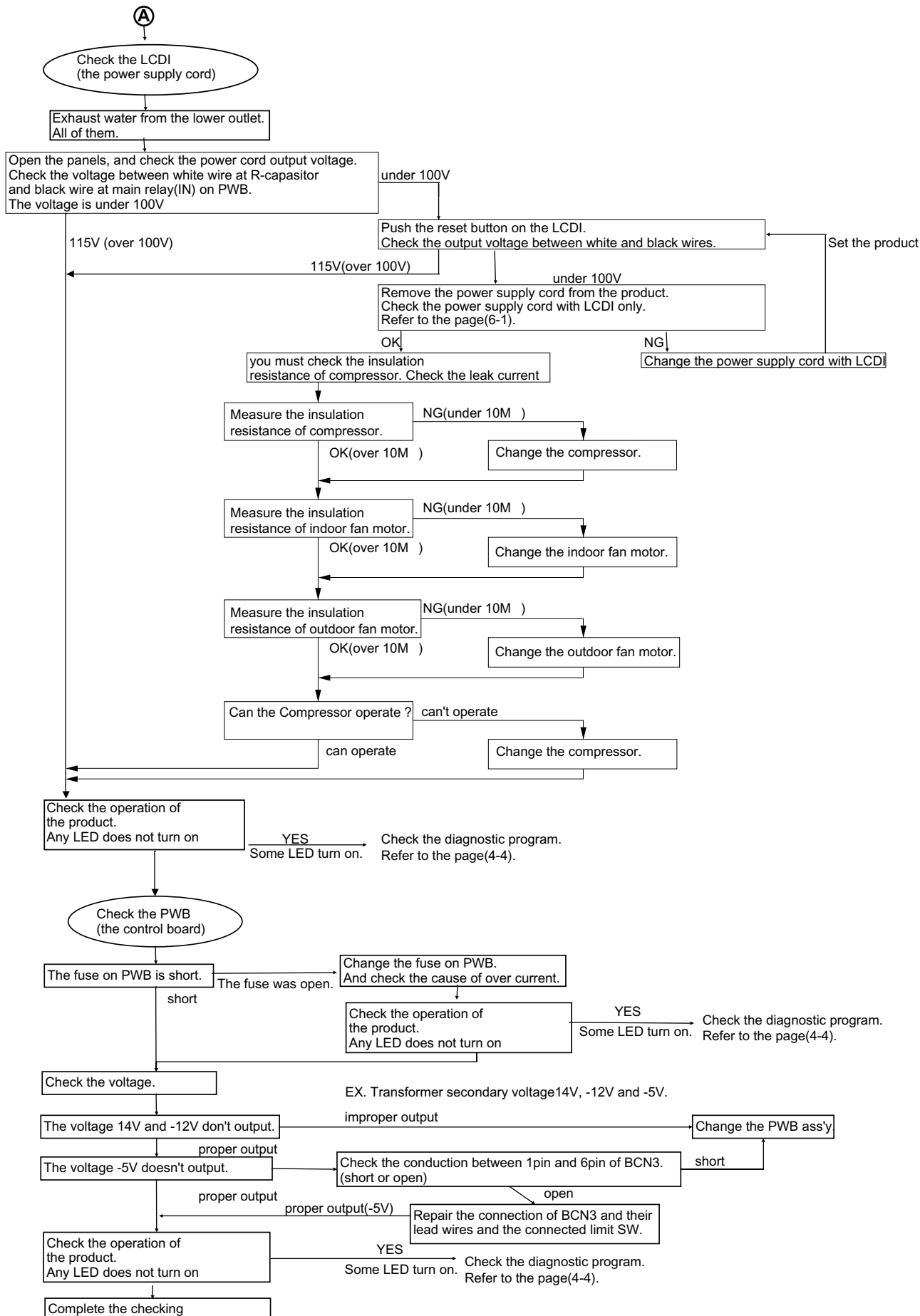

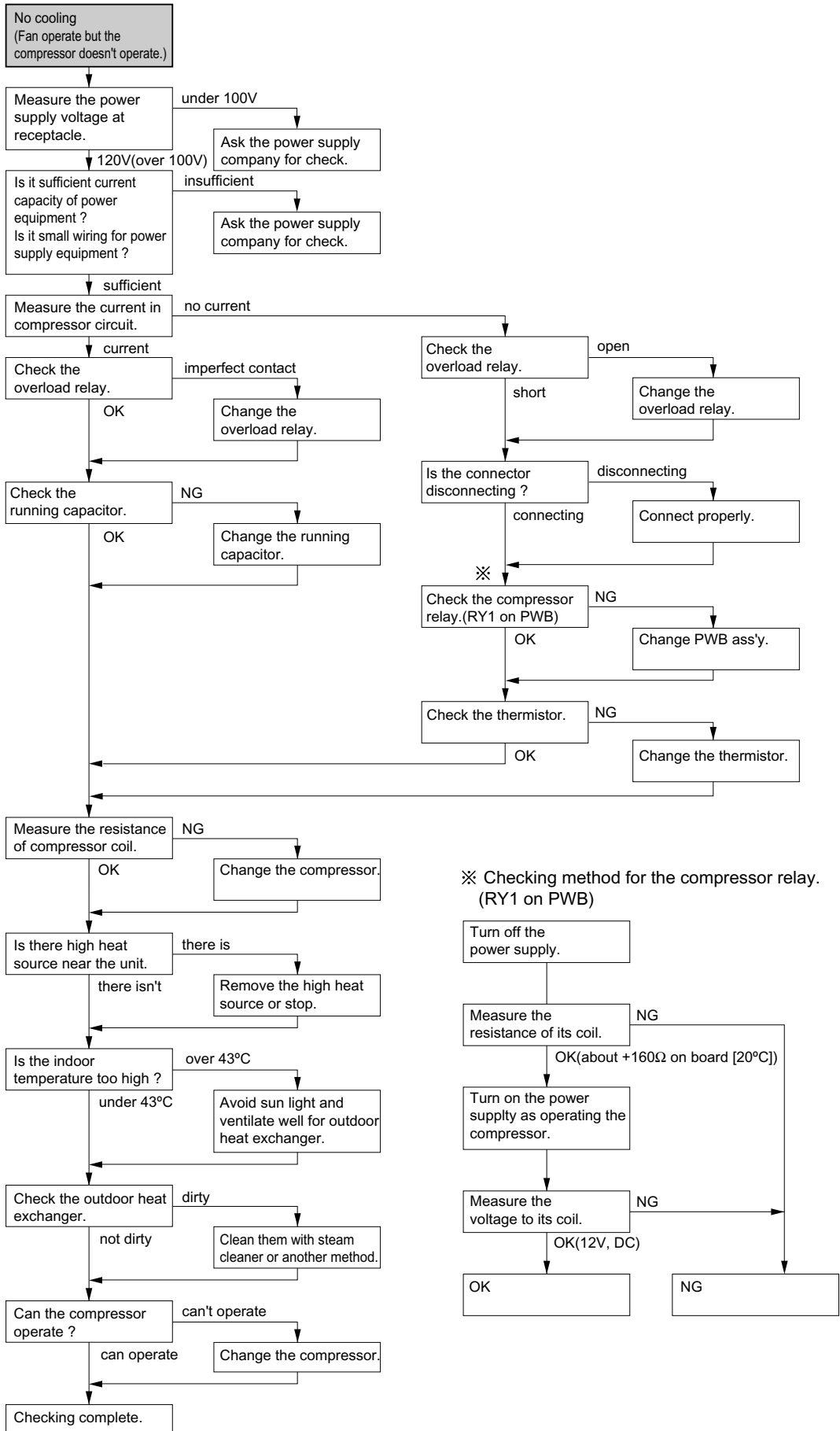

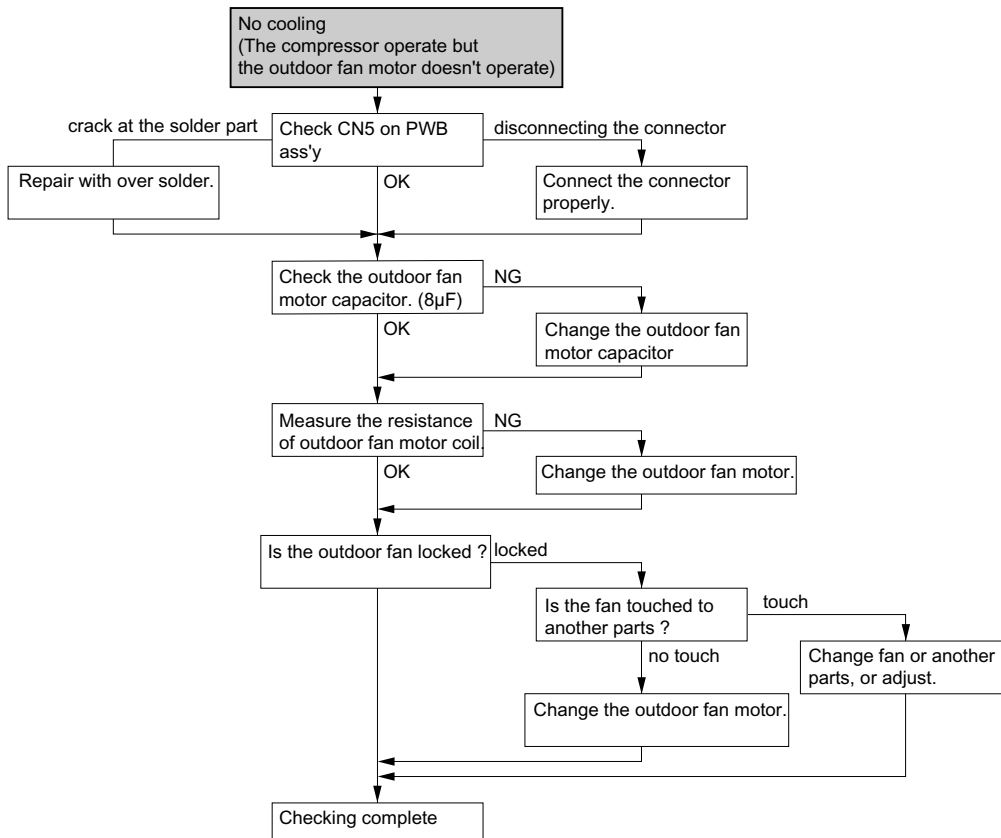
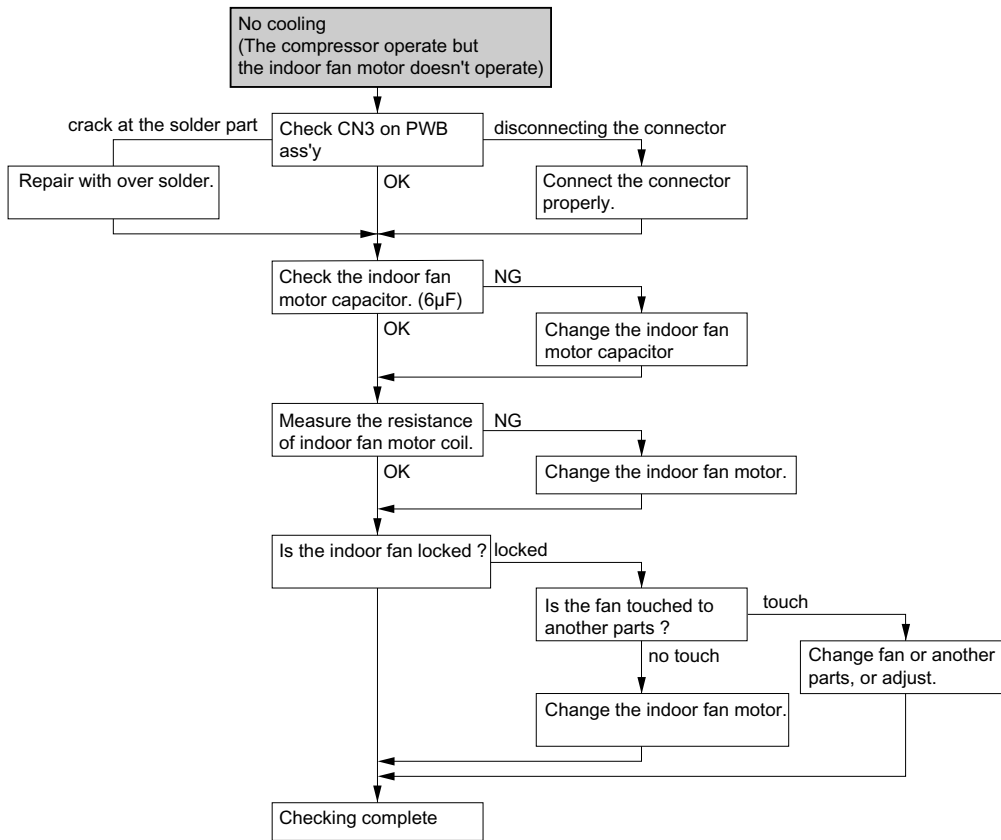

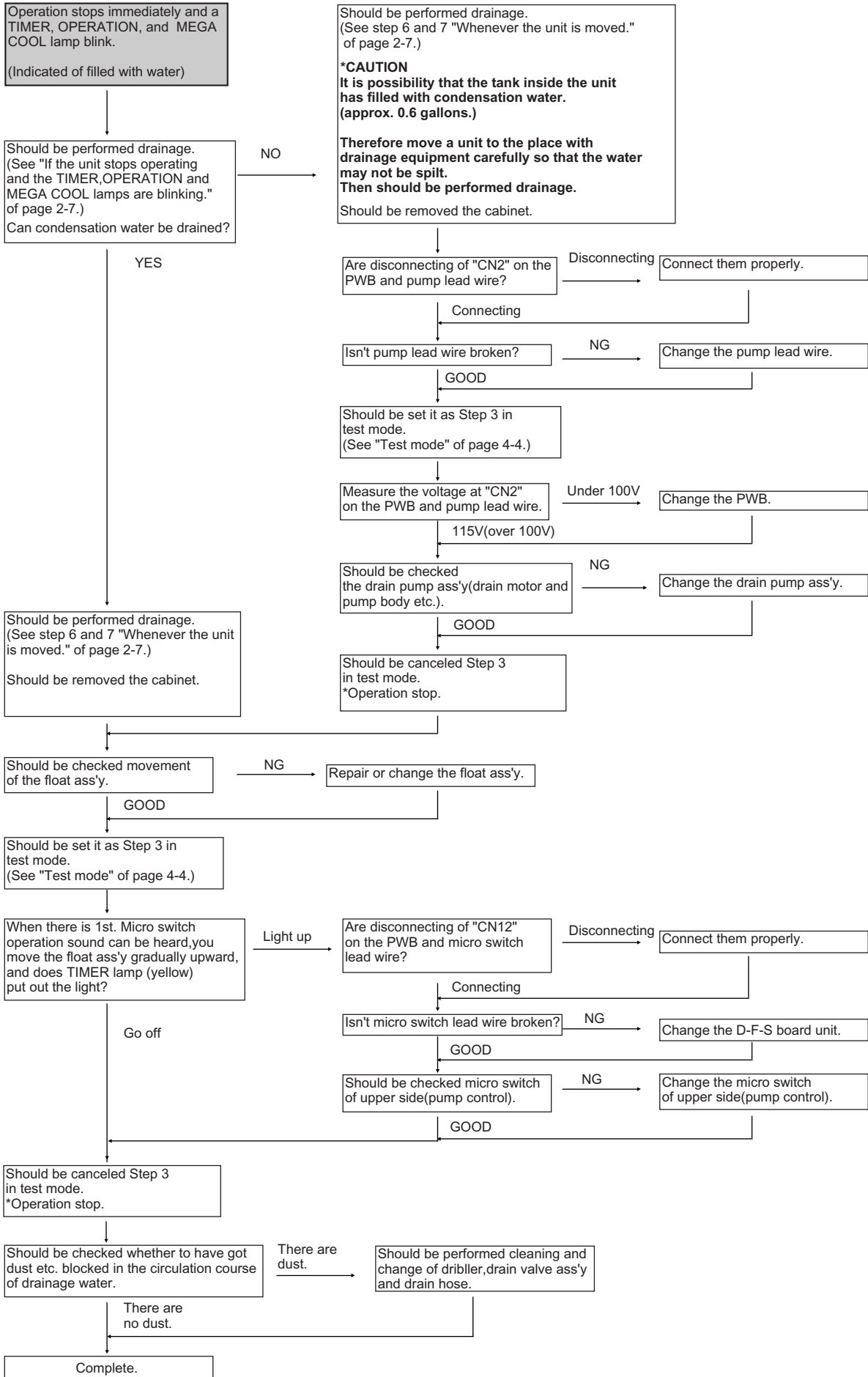

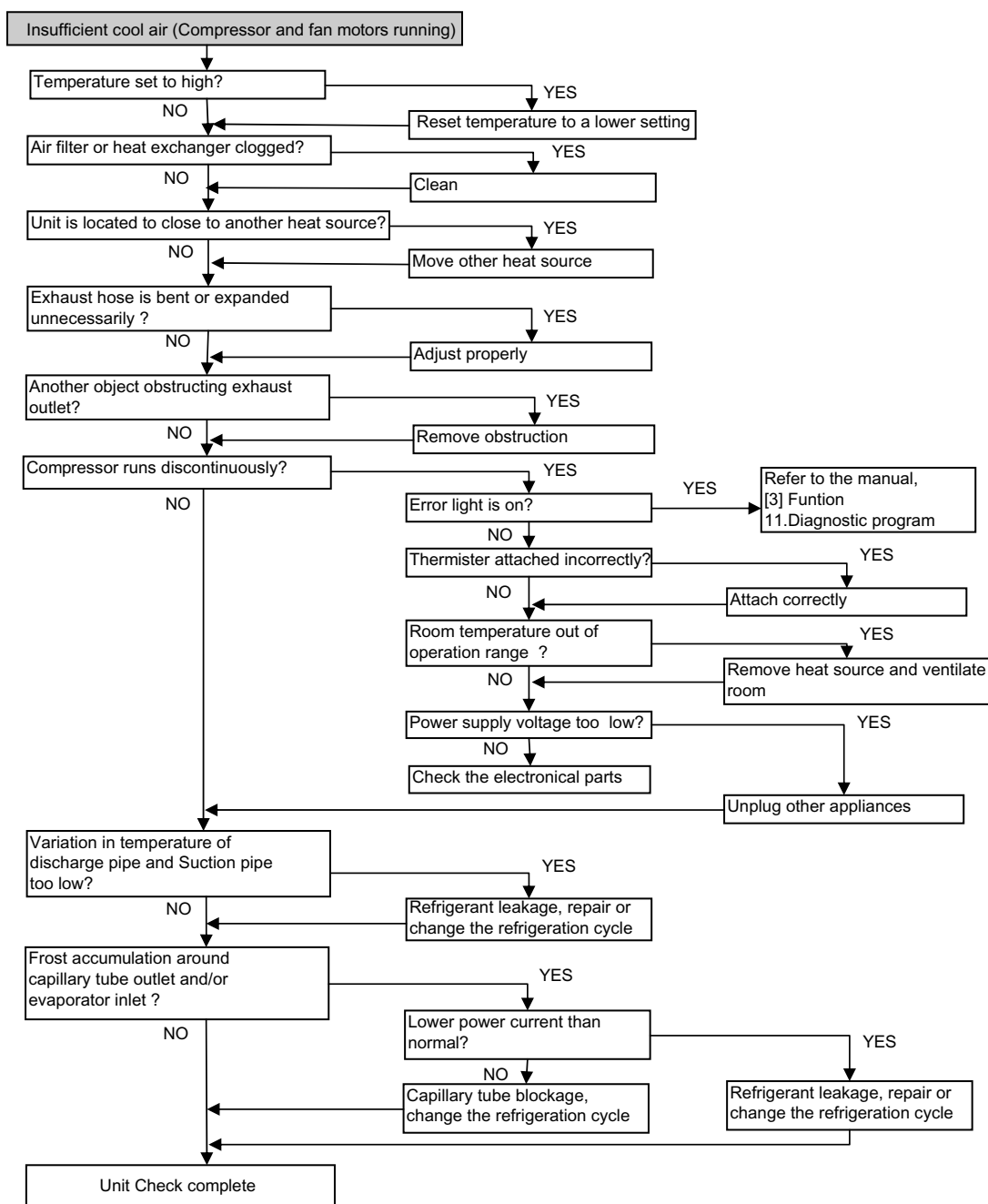
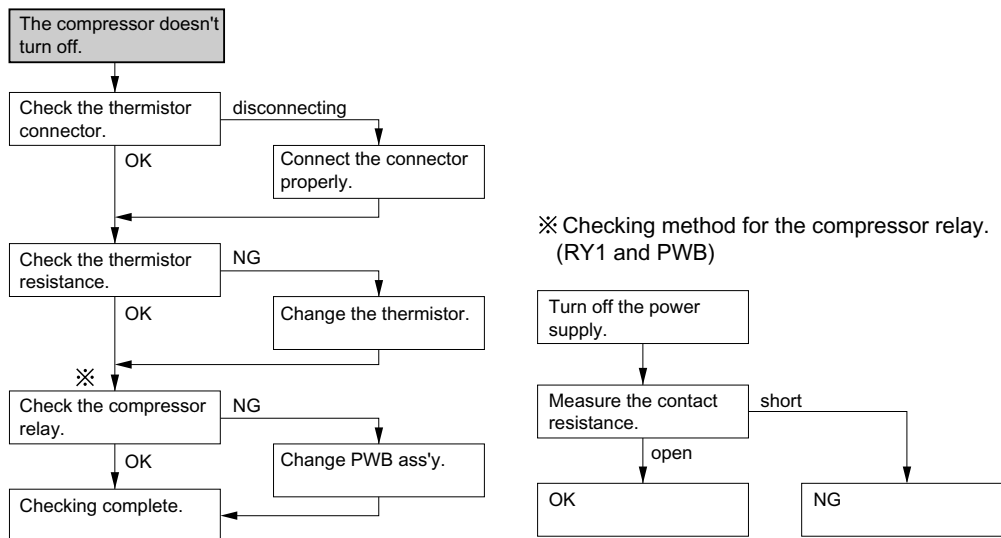

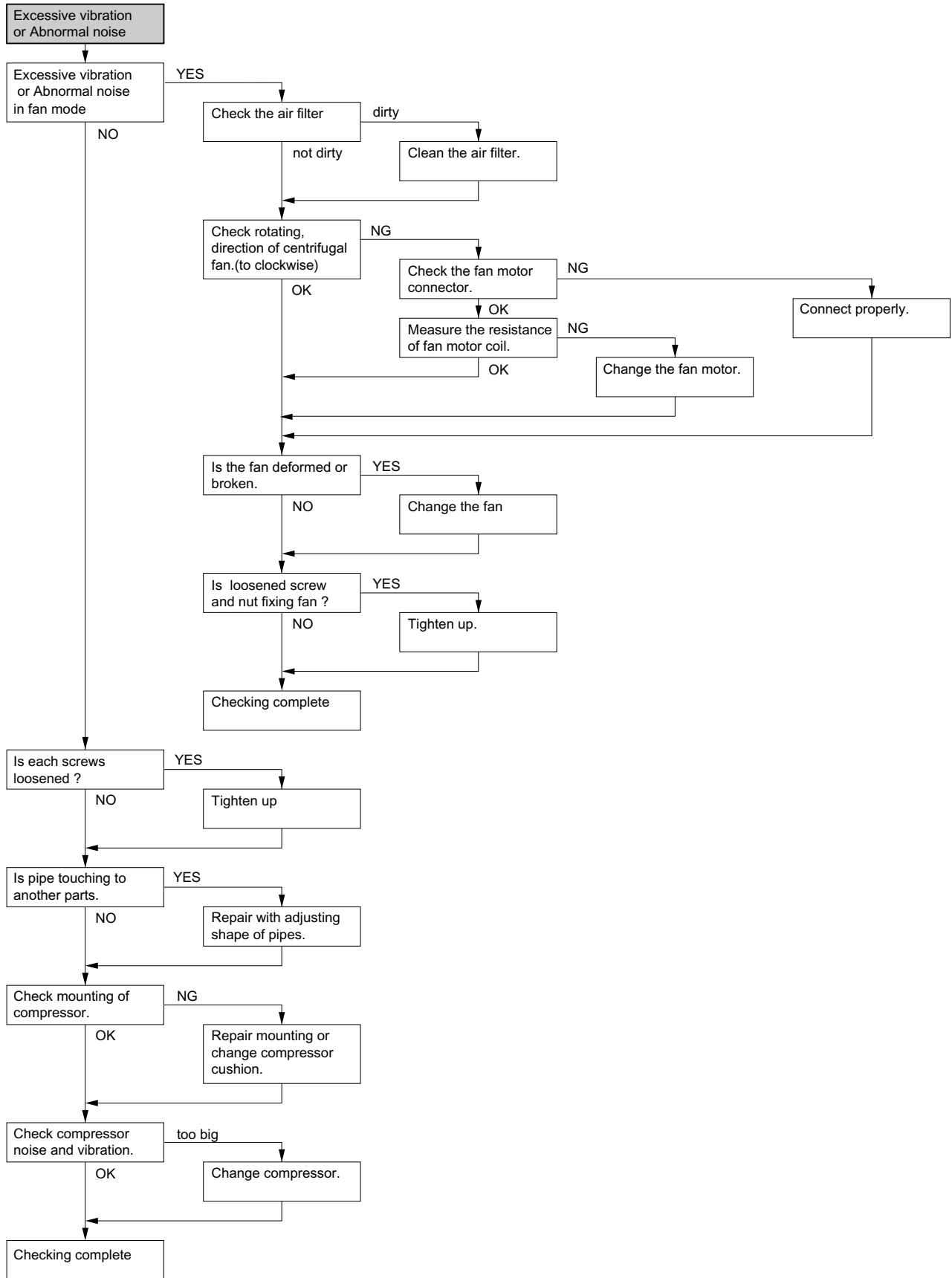

REPLACEMENT PARTS LIST

PORTABLE AIR CONDITIONER

MODELS **CV-P09LX**
CV-P10LC

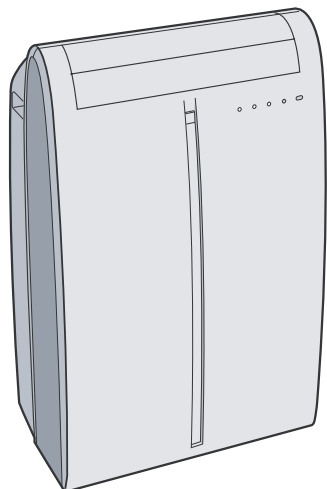

CONTENTS

- | | |
|----------------------------------|----------------------------------|
| [1] CV-P09LX (Outside parts) | [8] CV-P10LC (Inside parts) |
| [2] CV-P09LX (Inside parts) | [9] CV-P10LC (Control box parts) |
| [3] CV-P09LX (Control box parts) | [10] CV-P10LC (Cycle parts) |
| [4] CV-P09LX (Cycle parts) | [11] CV-P10LC (Accessory parts) |
| [5] CV-P09LX (Accessory parts) | [12] CV-P10LC (Packing parts) |
| [6] CV-P09LX (Packing parts) | ■ INDEX |
| [7] CV-P10LC (Outside parts) | |

"HOW TO ORDER REPLACEMENT PARTS"

To have your order filled promptly and correctly, please furnish the following information.

- | | |
|-----------------|----------------|
| 1. MODEL NUMBER | 2. REF. No. |
| 3. PART NO. | 4. DESCRIPTION |

MARK: SPARE PARTS-DELIVERY SECTION

For U.S.A. only

Contact your nearest SHARP Parts Distributor to order.

For location of SHARP Parts Distributor,
Please call Toll-Free;
1-800-BE-SHARP

Parts marked with "▲" are important for maintaining the safety of the set. Be sure to replace these parts with specified ones for maintaining the safety and performance of the set.

SHARP CORPORATION

This document has been published to be used for after sales service only.
The contents are subject to change without notice.

[1] CV-P09LX (Outside parts)

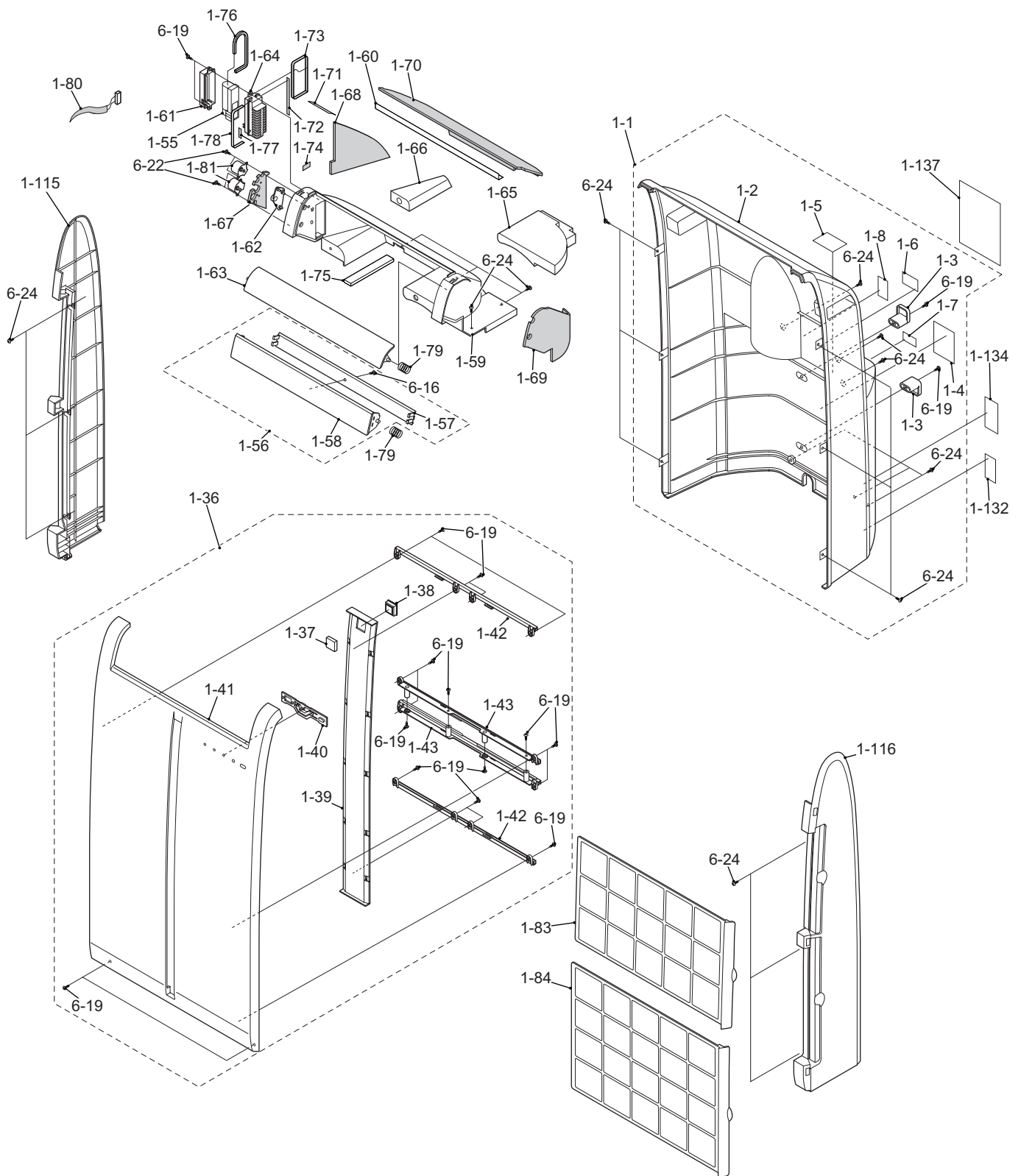

NO.	PARTS CODE	PRICE RANK	NEW MARK	PART RANK	DESCRIPTION
[1] CV-P09LX (Outside parts)					
1-1	CCAB-A421JBKZ	BH			Cabinet ass'y
1-2	GCAB-A292JBFA	BL			Cabinet
1-3	LHLD-A735JBFA	AD			Cord holder
1-4	TLAB-C990JBRZ	AF			Caution label
1-5	TLAB-C973JBRZ	AF			Caution label
1-6	TLAB-C974JBRZ	AF			Label
1-7	TLAB-C975JBRZ	AF			Label
1-8	TLAB-C976JBRZ	AF			Caution label
1-36	CPNL-A553JBKZ	BH			Front panel ass'y
1-37	HBDG-A002KKEA	AE			AI badge
1-38	HDEC-B192JBFA	AF			Cluster display
1-39	HPNL-A726JBFA	AW			Center panel
1-40	HPNL-A727JBFA	AZ			Display panel
1-41	HPNL-A815JBRA	BC			Front panel
1-42	PGID-A124JBFA	AF			Filter guide A
1-43	PGID-A125JBFA	AF			Filter guide B
1-55	CKITTA069AKKZ	BD			Plasmacluster unit
1-56	DLOV-A013JBKZ	AZ			H louver ass'y
1-57	MLOV-A413JBFA	AF			Horizontal louver C
1-58	MLOV-A412JBFA	AF			Horizontal louver B
1-59	GWAKPA173JBFA	BC			Top duct
1-60	LANG-A623JBPZ	AG			Top angle
1-61	LHLD-A737JBFA	AZ			Cluster holder
1-62	LSTP-A027JBFA	AM			Stopper
1-63	MLOV-A411JBFA	AF			Horizontal louver A
1-64	PCOV-B108JBFA	AZ			Cluster cover
1-65	PFPPFC769JBFZ	AF			Insulator A
1-66	PFPPFC770JBFZ	AF			Insulator B
1-67	PFPPFC771JBEZ	AF			Insulator C
1-68	PFPPFC772JBEZ	AF			Insulator D
1-69	PFPPFC773JBEZ	AF			Insulator E
1-70	PFPPFC774JBEZ	AF			Insulator F
1-71	PFPPFC775JBEZ	AF			Insulator G
1-72	PFPPFC830JBEZ	AC			Cl.cover insulator B
1-73	PFPPFC831JBEZ	AC			Cl.cover insulator D
1-74	PFPPFC832JBEZ	AC			Insulator H
1-75	PFPPFC862JBEZ	AC			Insulator I
1-76	PSEL-C876JBEZ	AC			Cluster insulator
1-77	PSEL-C877JBEZ	AC			Cl.cover insulator A
1-78	PSEL-C879JBEZ	AC			Cl.cover insulator C
1-79	PSPRCA018JBEZ	AF			Spring
1-80	QW-VZF419JBZZ	AF			Lead wire
1-81	RMOT-A061JBE0	AS			Louver motor
1-83	DFILMA001JBEA	AM			Ply filter A
1-84	DFILMA002JBEA	AM			Ply filter B
1-115	HPNL-A728JBFA	AW			Side panel L
1-116	HPNL-A729JBFA	AW			Side panel R
1-132	TLAB-C977JBRZ	AF			Caution label
1-134	TSPC-F428JBRZ	AK			Name badge
1-137	TLAB-C990JBRZ	AF			Caution label EN
6-16	XTPS730P10000	AC			Tapping screw
6-19	XTTS740P12000	AC			Tapping screw
6-22	XUPS740P08000	AC			Tapping screw
6-24	XTTS740P10000	AC			Tapping screw

NO.	PARTS CODE	PRICE RANK	NEW MARK	PART RANK	DESCRIPTION
[2] CV-P09LX (Inside parts)					
1-8	CCHS-A914JBKZ	AZ			Base pan ass'y
1-9	DCHS-A536JBTA	BB			Base pan ass'y
1-10	NKOM-A001JBEZ	AG			Caster
1-11	PGUM-A164JBEZ	AE			Motor cushion
1-12	PGUM-A165JBEZ	AE			Motor cushion B
1-13	PGUM-A166JBEZ	AE			Motor cushion C
1-14	CGUM-A001JBKZ				Drain plug
1-15	PSEL-C875JBEZ	AC			Insulator
1-16	PSRA-A172JBFA	AX			Drain tray
1-17	CKES-A162JBKZ	AT			Orifice ass'y
1-18	MJNT-A023JBFA	AF			Louver link
1-19	MLOV-A409JBFA	AF			Vertical louver A
1-20	MLOV-A410JBFA	AF			Vertical louver B
1-21	PFPFPC765JBEZ	AE			Evaporator insulator
1-22	PFPFPC826JBEZ	AC			Orifice insulator A
1-23	PFPFPC827JBEZ	AC			Orifice insulator B
1-24	PFPFPC828JBEZ	AC			Orifice insulator C
1-25	PFPFPC829JBEZ	AC			Orifice insulator D
1-26	PKESSA090JBFA	AX			Orifice
1-27	CPMP-A005JBKZ	AN			Drain pump ass'y
1-28	LBND-A042JBE0	AC			Wire fixing band
1-29	LBNDKA132JBEZ	AE			Band
1-34	PHOS-A045JBEZ	AM			Drain hose A
1-44	CVLV-A755JBKZ	BE			Drain valve ass'y
1-45	LANG-A615JBWZ	AK			Stay angle L
1-46	PCOV-B297JBEZ	AK			Cover F
1-48	LPLTMA210JBWZ	AQ			Bulkhead R
1-50	PCOV-B298JBEZ	AK			Cover R
1-51	LPLTMA211JBWZ	AQ			Bulkhead L
1-52	PCOV-B299JBEZ	AN			Cover
1-53	LPLTMA207JBWZ	AL			Half plate
1-54	PCOV-B300JBEZ	AN			Cover T
1-82	DANG-A049JBKZ	AZ			Stay angle L ass'y
1-85	DPLT-A074JBKZ	AV			Bulkhead R ass'y
1-86	DPLT-A075JBKZ	AX			Bulkhead L ass'y
1-87	DPLT-A076JBKZ	AZ			Half plate ass'y
1-88	CMOT-A439JBKZ	BL			Fan motor sub ass'y
1-89	NFANSA045JBFZ	AX			Centrifugal fan-OUT
1-90	LANG-A617JBWZ	AL			Motor cover
1-91	LHLDW0364JBE0	AA			Wire holder
1-92	LHLDW0370JBE0	AA			Wire holder
1-97	PKESSA092JBFA	AX			Out casing A
1-98	PKESSA093JBFA	AX			Out casing B
1-99	PKESSA094JBFA	AX			Out casing C
1-100	CMOT-A440JBKZ	BG			Fan motor sub ass'y
1-101	NFANSA049JBFZ	AV			Centrifugal fan-IN
1-102	LANG-A606JBFZ	AM			Fan motor angle
1-103	LANG-A614JBPZ	AK			Casing cover
1-104	LANG-A618JBPZ	AK			Motor cover IN
1-106	PKESSA091JBFZ	AX			In casing
1-107	DSW-MA003JBKZ	AS			Float switch ass'y
1-108	CFLO-A001JBKZ	AK			Float ass'y
1-111	LHLD-A739JBFA	AZ			SW stay
1-112	PCOV-B112JBFZ	AF			SW cover
1-113	PFLO-A006JBFZ	AE			Float C
1-114	QSW-MA009JBZZ	AL			Micro switch
1-117	LANG-A613JBWZ	AR			Stay angle R
1-121	LHLDWA042JBEZ	AE			Wire holder
1-122	LHLDW0366JBE0	AA			Wire holder
1-123	LHLDW0368JBE0	AA			Wire holder
2-18	PCOV-B105JBFZ	AG			LED guide
2-19	DPWBFA395JBKZ	AS			D-F-S board unit
2-21	PSHE-A230JBEZ	AF			Sheet
6-2	LX-BZA360JBEZ	AF			Special screw
6-3	LX-NZA316JBEZ	AF			Special nut
6-5	LX-WZA048JBEZ	AD			Washer
6-8	XCTS740P10000	AC			Tapping screw
6-9	XHTS740P08000	AC			Tap tight screw
6-15	XTPS723P14000	AC			Tapping screw
6-17	XTPS740P12000	AC			Tapping screw
6-19	XTTS740P12000	AC			Tapping screw
6-20	XTTS740P14000	AC			Tapping screw
6-21	XTTS740P16000	AC			Tapping screw
6-23	XWSS700-25000	AC			Spring washer
6-24	XTTS740P10000	AC			Tapping screw

[3] CV-P09LX (Control box parts)

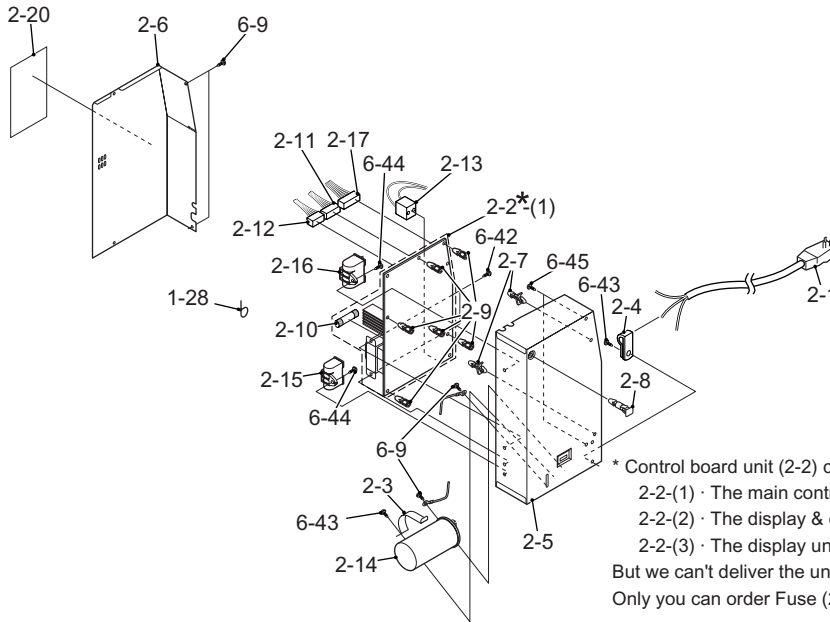

* Control board unit (2-2) consists of three units.
 2-2-(1) · The main control unit with Fuse (2-10).
 2-2-(2) · The display & detector unit.
 2-2-(3) · The display unit for the cluster.
 But we can't deliver the units separately.
 Only you can order Fuse (2-10).

NO.	PARTS CODE	PRICE RANK	NEW MARK	PART RANK	DESCRIPTION
[3] CV-P09LX (Control box parts)					
1-28	LBND-A042JBE0	AC			Wire fixing band
2-1	CACC-A030JBKZ	BM			Pack ass'y
2-2	DPWBFA484JBKZ	BT			Control board unit
2-3	LBNDKA130JBWZ	AK			Capacitor clamp
2-4	LHLDW0366JBE0	AA			Wire holder
2-5	PBOX-A450JBWZ	AS			Control box
2-6	PCOV-B126JBWZ	AP			Control box cover
2-7	PSPA-A146JBE0	AC			Spacer
2-8	PSPA-A177JBZZ	AE			PWB spacer
2-9	PSPA-A178JBZZ	AE			PWB spacer
2-10	QFS-AA048JBE0	AB			Fuse
2-11	QW-VZF465JBZZ				Lead wire
2-12	QW-VZF466JBZZ				Lead wire
2-13	QW-VZE999JBZZ	AK			Lead wire
2-14	RC-HZA484JBZZ	AY			Running capacitor
2-15	RC-HZA509JBZZ	AP			Fan motor capacitor
2-16	RC-HZA529JBZZ	AR			Fan motor capacitor
2-17	RH-HXA047JBZZ	AV			Thermistor
2-20	TLABCC034JBRZ	AD			Wiring diagram
6-9	XHTS740P08000	AC			Tap tight screw (for earth leads & Control box)
6-42	XJTS740P08000	AC			Tap tight screw (for the transformer)
6-43	XJTS740P10000	AC			Tap tight screw (for Running capacitor & Wire holder)
6-44	XJTS740P12000	AC			Tap tight screw (for Fan motor capacitor)
6-45	XTPS740P10000	AC			Tapping screw (for Control box ass'y)

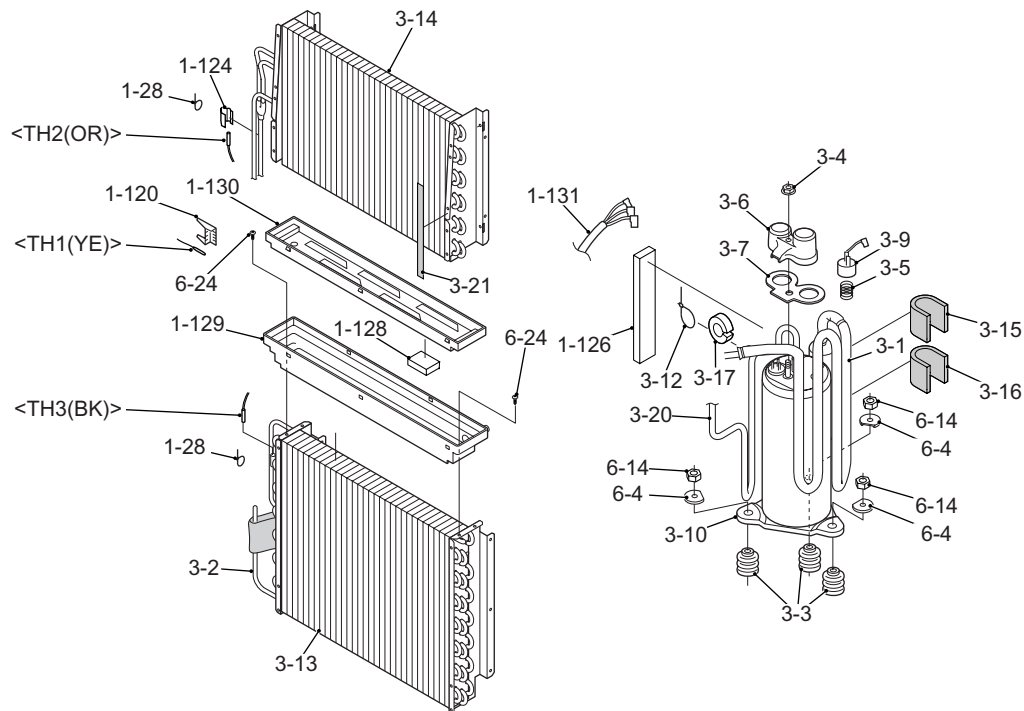
[4] CV-P09LX (Cycle parts)

NO.	PARTS CODE	PRICE RANK	NEW MARK	PART RANK	DESCRIPTION
[4] CV-P09LX (Cycle parts)					
1-28	LBND-A042JBE0	AC			Wire fixing band
1-120	LHLD-A315JBF0	AE			Thermistor holder
1-124	MSPR-A027JBE0	AB			Thermistor spring
1-126	PCOV-B154JBEZ	AG			Cover M
1-128	PSEL-C882JBEZ	AC			Drain pan insulator
1-129	PSRA-A174JBFZ	AZ			Dribbler
1-130	PSRA-A173JBFZ	AX			Drain pan
1-131	QW-IZA083JBZZ	AP			Comp wiring
3-1	CPIPCA929JBKZ	AX			Suction tube ass'y
3-2	DCPY-A340JBKZ	AR			Capillary tube ass'y
3-3	GLEG-A103JBE0	AG			Compressor cushion
3-4	LX-NZA148JBE0	AD			Frang nut
3-5	MSPR-A114JBE0	AF			Protector spring
3-6	PCOV-A371JBE0	AF			Terminal cover
3-7	PSEL-B160JBE0	AH			Terminal gasket
3-9	RHOG-A233JBEZ	AU			Overload relay
3-10	PCMPRA468JBEZ	CA			Compressor
3-12	LBND-A046JBE0	AE			Wire fixing band
3-13	PCON-A569JBEZ	BT			Condenser
3-14	PEVA-A586JBEZ	BQ			Evaporator
3-15	PFPFPC834JBEZ	AD			Insulator A
3-16	PFPFPC835JBEZ	AD			Insulator B
3-17	PGUM-A113JBE0	AH			Damper rubber
3-20	PPIPCH210JB1Z	AP			Discharge tube
3-21	PSEL-C880JBEZ	AC			Eva insulator
6-4	LX-WZA047JBEZ	AC			Comp.washer
6-14	XNES780-65000	AC			Nut
6-24	XTTS740P10000	AC			Tapping screw

[5] CV-P09LX (Accessory parts)

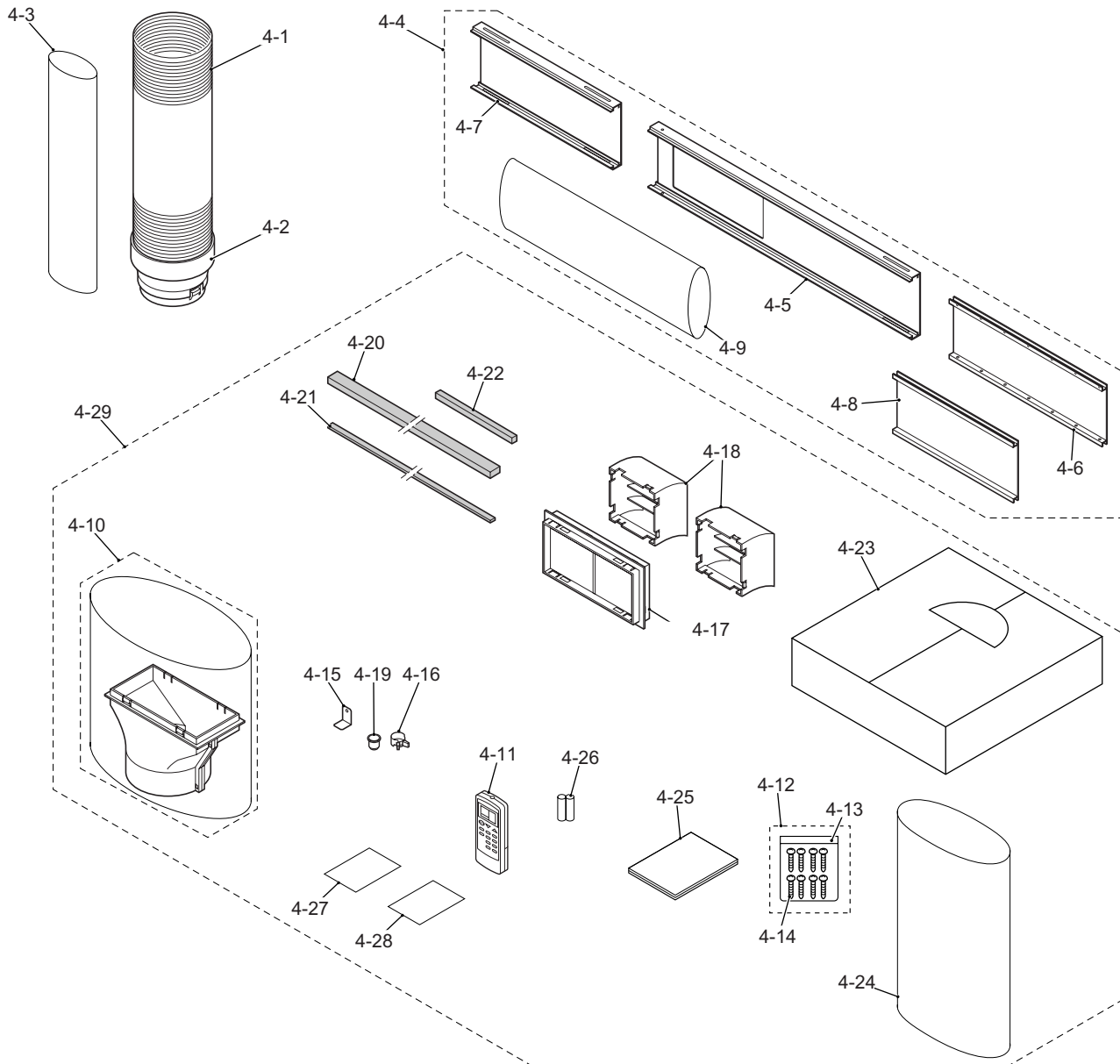

NO.	PARTS CODE	PRICE RANK	NEW MARK	PART RANK	DESCRIPTION
[5] CV-P09LX (Accessory parts)					
4-1	PDUC-A011JBFA	AZ			Duct hose
4-2	PJNT-A007JBFA	AH			Connector C
4-3	SSAKAA109JBEZ	AE			Bag
4-4	CPNL-A518JBKZ	BD			Window panel ass'y
4-5	PPNLCA011JBFA	AW			Window panel A
4-6	PPNLCA012JBFA	AP			Window panel B
4-7	PPNLCA013JBFA	AP			Window panel C
4-8	PPNLCA014JBFA	AL			Panel cover
4-9	SSAKAA111JBEZ	AE			Bag
4-10	CJNT-A001JBKZ	AZ			Connector ass'y
4-11	CRMC-A663JBEZ	AY			Remote controller
4-12	DX-BZA049JBKZ	AS			Screw kit
4-13	SSAKAA018YDE0	AB			Bag
4-14	XMP5740P25000	AC			Wood screw
4-15	LANG-A616JBTA	AK			Panel angle
4-16	LBNDKA136JBEZ	AF			Band 5/8
4-17	LHLD-A740JBFA	AQ			Holder
4-18	PCOV-B115JBFA	AG			Cover
4-19	PGUMMA347JBEZ	AE			Drain joint
4-20	PSEL-A931JBE0	AH			Window insulator
4-21	PSEL-C848JBEZ	AD			Panel insulator
4-22	PSEL-C881JBEZ	AC			Panel insulator
4-23	SPAKCB932JBEZ	AH			Accessory case
4-24	SSAKHA149YDE0	AC			Bag

NO.	PARTS CODE	PRICE RANK	NEW MARK	PART RANK	DESCRIPTION
[5] CV-P09LX (Accessory parts)					
4-25	TINSEA467JBRZ	AN			Operation manual
4-26	UBATUA027JBE0	AE			Battery pack
4-27	TLAB-C979JBRZ	AF			Caution label
4-28	TLAB-C989JBRZ	AF			Caution label FR
4-29	DFZK-B641JBKZ	BL			Accessory sub kit

[6] CV-P09LX (Packing parts)

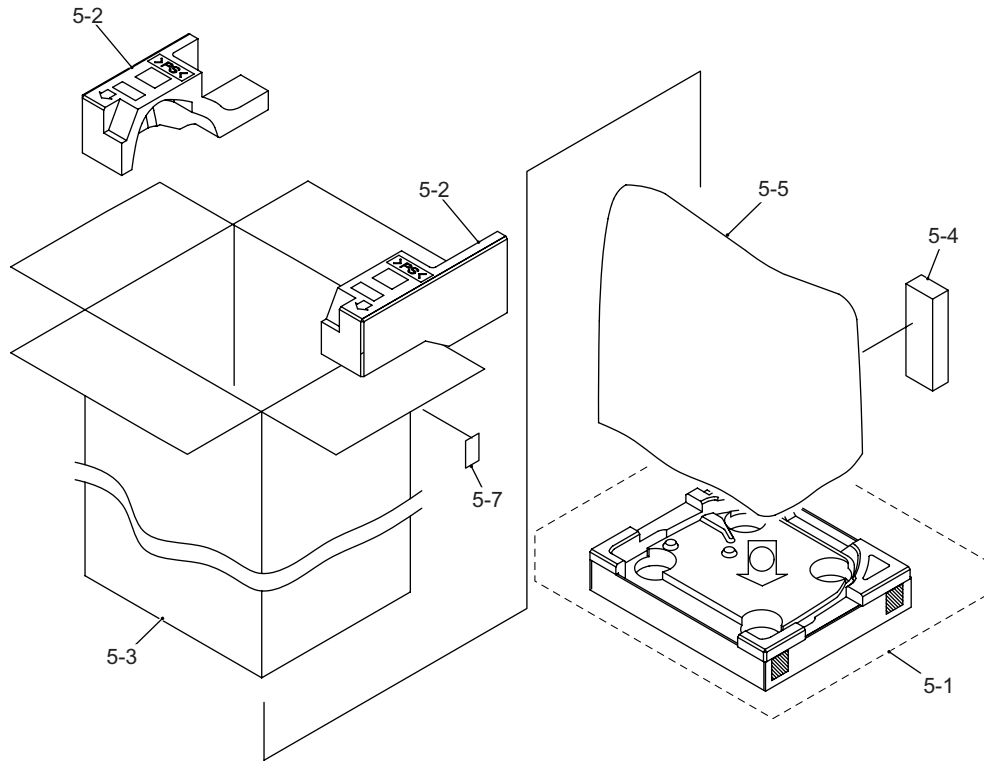

NO.	PARTS CODE	PRICE RANK	NEW MARK	PART RANK	DESCRIPTION
[6] CV-P09LX (Packing parts)					
5-1	CPADBA114JBKZ	AF			Bottom pad ass'y
5-2	CPADBA111JBKZ	AR			Top pad ass'y
5-3	DPAKCA005JBKZ	AZ			Packing case ass'y
5-4	SPADBA321JBEZ	AD			Pad
5-5	SSAKHA018JBEZ	AF			Bag
5-7	TLABKE115JBRZ	AF			Number card

[7] CV-P10LC (Outside parts)

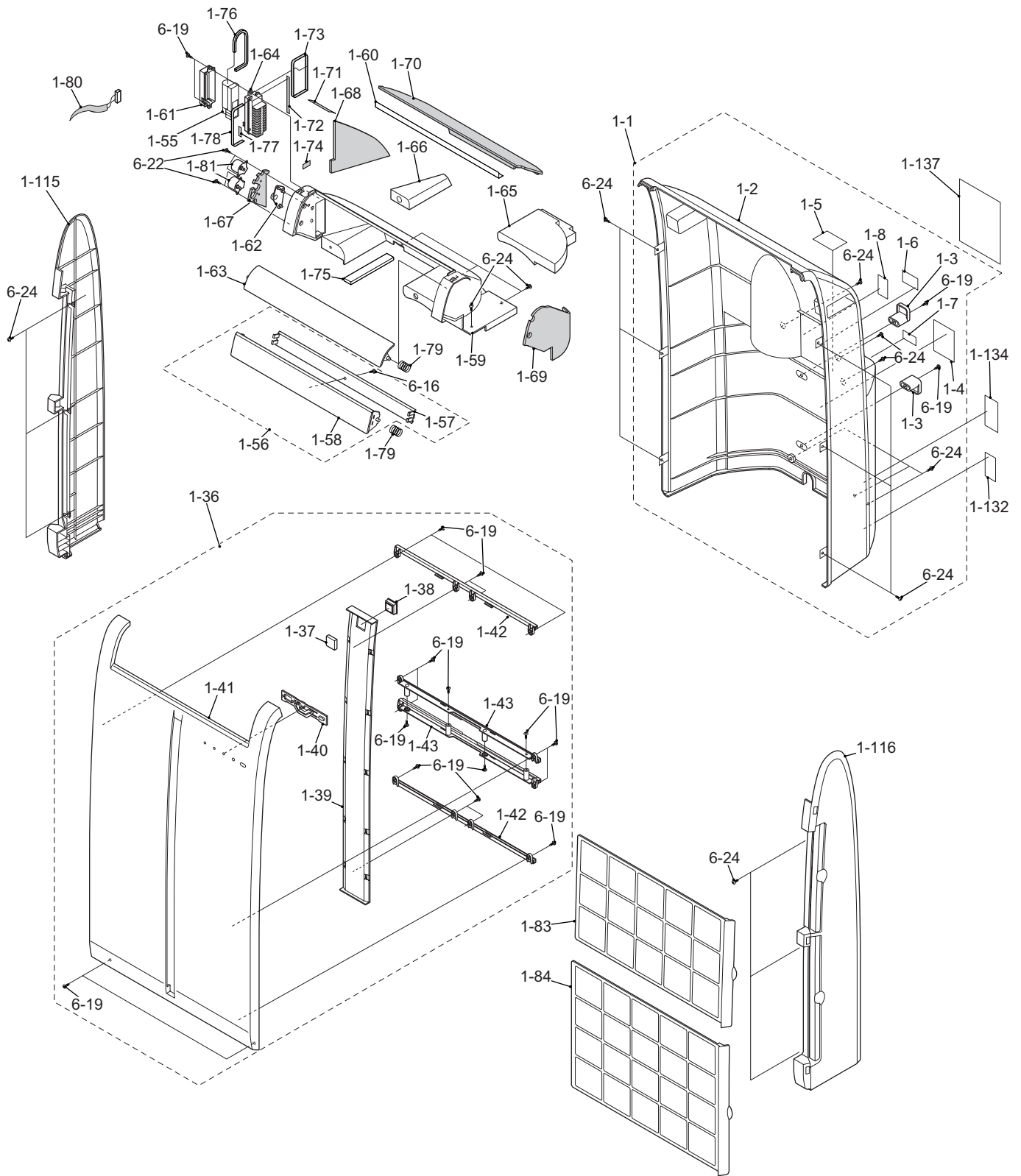

NO.	PARTS CODE	PRICE RANK	NEW MARK	PART RANK	DESCRIPTION
[7] CV-P10LC (Outside parts)					
1-1	CCAB-A422JBKZ	BH			Cabinet ass'y
1-2	GCAB-A292JBFC	BG			Cabinet
1-3	LHLD-A735JBFB	AD			Cord holder
1-4	TLAB-C990JBRZ	AF			Caution label
1-5	TLAB-C973JBRZ	AF			Caution label
1-6	TLAB-C974JBRZ	AF			Label
1-7	TLAB-C975JBRZ	AF			Label
1-8	TLAB-C976JBRZ	AF			Caution label
1-36	CPNL-A554JBKZ	BH			Front panel ass'y
1-37	HBDG-A002KKEA	AE			AI badge
1-38	HDEC-B192JBFA	AF			Cluster display
1-39	HPNL-A726JBFC	AR			Center panel
1-40	HPNL-A727JBFA	AZ			Display panel
1-41	HPNL-A815JBRB	BC			Front panel
1-42	PGID-A124JBFC	AK			Filter guide A
1-43	PGID-A125JBFC	AK			Filter guide B
1-55	CKITTA069AKKZ	BD			Plasmacluster unit
1-56	DLOV-A016JBKZ	AS			H louver ass'y
1-57	MLOV-A413JBFB	AK			Horizontal louver C
1-58	MLOV-A412JBFB	AN			Horizontal louver B
1-59	GWAKPA173JBFA	BC			Top duct
1-60	LANG-A623JBPZ	AG			Top angle
1-61	LHLD-A737JBFA	AZ			Cluster holder
1-62	LSTP-A027JBFA	AM			Stopper
1-63	MLOV-A411JBFB	AN			Horizontal louver A
1-64	PCOV-B108JBFA	AZ			Cluster cover
1-65	PFPPFC769JBFZ	AF			Insulator A
1-66	PFPPFC770JBFZ	AF			Insulator B
1-67	PFPPFC771JBEZ	AF			Insulator C
1-68	PFPPFC772JBEZ	AF			Insulator D
1-69	PFPPFC773JBEZ	AF			Insulator E
1-70	PFPPFC774JBEZ	AF			Insulator F
1-71	PFPPFC775JBEZ	AF			Insulator G
1-72	PFPPFC830JBEZ	AC			Cl.cover insulator B
1-73	PFPPFC831JBEZ	AC			Cl.cover insulator D
1-74	PFPPFC832JBEZ	AC			Insulator H
1-75	PFPPFC862JBEZ	AC			Insulator I
1-76	PSEL-C876JBEZ	AC			Cluster insulator
1-77	PSEL-C877JBEZ	AC			Cl.cover insulator A
1-78	PSEL-C879JBEZ	AC			Cl.cover insulator C
1-79	PSPRCA018JBEZ	AF			Spring
1-80	QW-VZF419JBZZ	AF			Lead wire
1-81	RMOT-A061JBE0	AS			Louver motor
1-83	DFILMA001JBEC	AR			Ply filter A
1-84	DFILMA002JBEC	AS			Ply filter B
1-115	HPNL-A728JBFC	AU			Side panel L
1-116	HPNL-A729JBFC	AU			Side panel R
1-132	TLAB-C977JBRZ	AF			Caution label
1-134	TSPC-F430JBRZ	AK			Name badge
1-137	TLAB-C990JBRZ	AF			Caution label EN
6-16	XTPS730P10000	AC			Tapping screw
6-19	XTTS740P12000	AC			Tapping screw
6-22	XUPS740P08000	AC			Tapping screw
6-24	XTTS740P10000	AC			Tapping screw

[8] CV-P10LC (Inside parts)

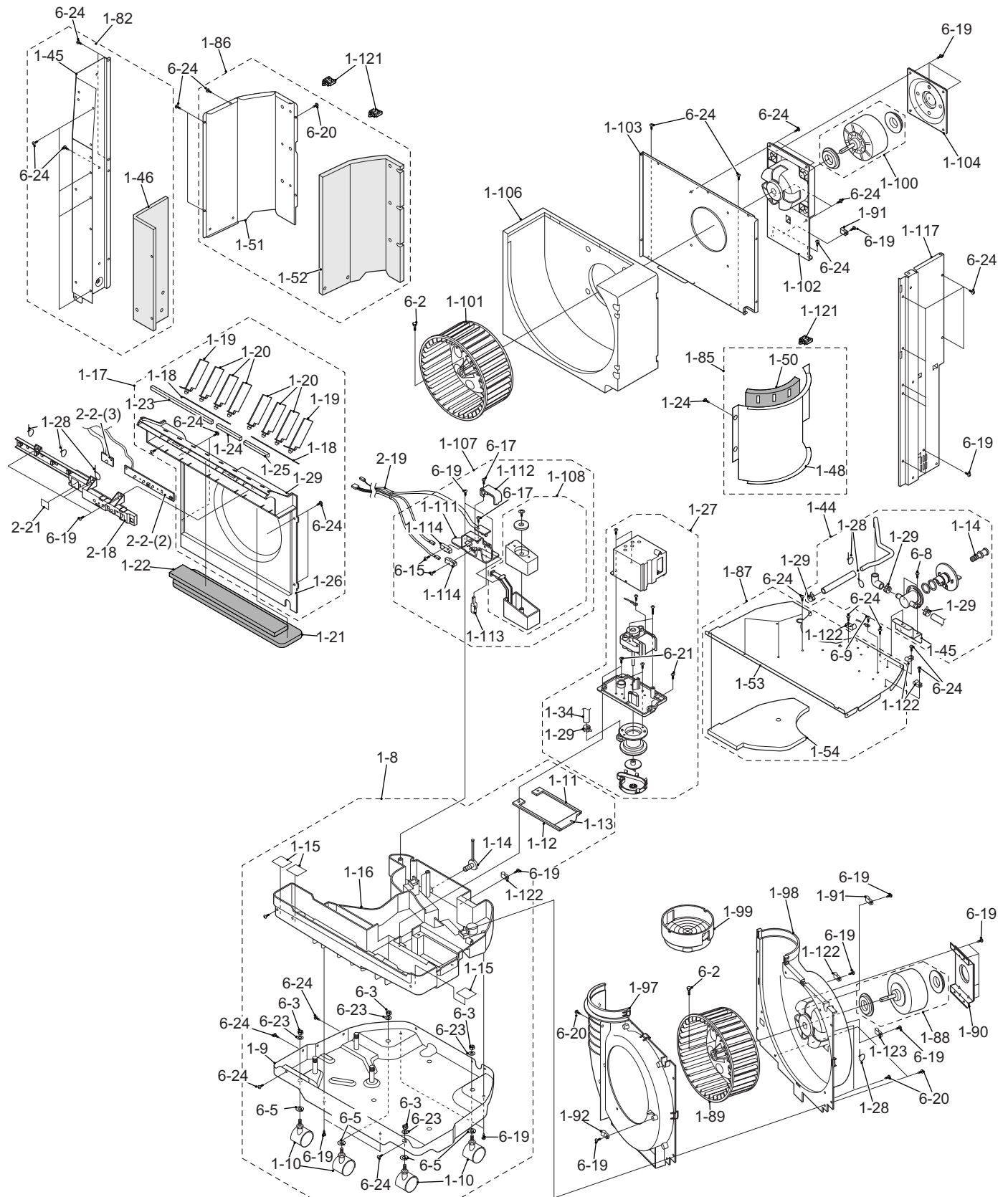

NO.	PARTS CODE	PRICE RANK	NEW MARK	PART RANK	DESCRIPTION
[8] CV-P10LC (Inside parts)					
1-8	CCHS-A914JBKZ	AZ			Base pan ass'y
1-9	DCHS-A536JBTA	BB			Base pan ass'y
1-10	NKOM-A001JBEZ	AG			Caster
1-11	PGUM-A164JBEZ	AE			Motor cushion
1-12	PGUM-A165JBEZ	AE			Motor cushion B
1-13	PGUM-A166JBEZ	AE			Motor cushion C
1-14	CGUM-A001JBKZ	--			Drain plug
1-15	PSEL-C875JBEZ	AC			Insulator
1-16	PSRA-A172JBFA	AX			Drain tray
1-17	CKES-A162JBKZ	AT			Orifice ass'y
1-18	MJNT-A023JBFA	AF			Louver link
1-19	MLOV-A409JBFA	AF			Vertical louver A
1-20	MLOV-A410JBFA	AF			Vertical louver B
1-21	PFPFPC765JBEZ	AE			Evaporator insulator
1-22	PFPFPC826JBEZ	AC			Orifice insulator A
1-23	PFPFPC827JBEZ	AC			Orifice insulator B
1-24	PFPFPC828JBEZ	AC			Orifice insulator C
1-25	PFPFPC829JBEZ	AC			Orifice insulator D
1-26	PKESSA090JBFA	AX			Orifice
1-27	CPMP-A005JBKZ	AN			Drain pump ass'y
1-28	LBND-A042JBE0	AC			Wire fixing band
1-29	LBNDKA132JBEZ	AE			Band
1-34	PHOS-A045JBEZ	AM			Drain hose A
1-44	CVLV-A755JBKZ	BE			Drain valve ass'y
1-45	LANG-A615JBWZ	AK			Stay angle L
1-46	PCOV-B297JBEZ	AK			Cover F
1-48	LPLTMA210JBWZ	AQ			Bulkhead R
1-50	PCOV-B298JBEZ	AK			Cover R
1-51	LPLTMA211JBWZ	AQ			Bulkhead L
1-52	PCOV-B299JBEZ	AN			Cover
1-53	LPLTMA207JBWZ	AL			Half plate
1-54	PCOV-B300JBEZ	AN			Cover T
1-82	DANG-A049JBKZ	AZ			Stay angle L ass'y
1-85	DPLT-A074JBKZ	AV			Bulkhead R ass'y
1-86	DPLT-A075JBKZ	AX			Bulkhead L ass'y
1-87	DPLT-A076JBKZ	AZ			Half plate ass'y
1-88	CMOT-A439JBKZ	BL			Fan motor sub ass'y
1-89	NFANSA045JBFZ	AX			Centrifugal fan-OUT
1-90	LANG-A617JBWZ	AL			Motor cover
1-91	LHLDW0364JBE0	AA			Wire holder
1-92	LHLDW0370JBE0	AA			Wire holder
1-97	PKESSA092JBFA	AX			Out casing A
1-98	PKESSA093JBFA	AX			Out casing B
1-99	PKESSA094JBFA	AX			Out casing C
1-100	CMOT-A440JBKZ	BG			Fan motor sub ass'y
1-101	NFANSA049JBFZ	AV			Centrifugal fan-IN
1-102	LANG-A606JBFZ	AM			Fan motor angle
1-103	LANG-A614JBPZ	AK			Casing cover
1-104	LANG-A618JBPZ	AK			Motor cover IN
1-106	PKESSA091JBFZ	AX			In casing
1-107	DSW-MA003JBKZ	AS			Float switch ass'y
1-108	CFLO-A001JBKZ	AK			Float ass'y
1-111	LHLD-A739JBFA	AZ			SW stay
1-112	PCOV-B112JBFZ	AF			SW cover
1-113	PFLO-A006JBFZ	AE			Float C
1-114	QSW-MA009JBZZ	AL			Micro switch
1-117	LANG-A613JBWZ	AR			Stay angle R
1-121	LHLDWA042JBEZ	AE			Wire holder
1-122	LHLDW0366JBE0	AA			Wire holder
1-123	LHLDW0368JBE0	AA			Wire holder
2-18	PCOV-B105JBFZ	AG			LED guide
2-19	DPWBFA395JBKZ	AS			D-F-S board unit
2-21	PSHE-A230JBEZ	AF			Sheet
6-2	LX-BZA360JBEZ	AF			Special screw
6-3	LX-NZA316JBEZ	AF			Special nut
6-5	LX-WZA048JBEZ	AD			Washer
6-8	XCTS740P10000	AC			Tapping screw
6-9	XHTS740P08000	AC			Tap tight screw
6-15	XTPS723P14000	AC			Tapping screw
6-17	XTPS740P12000	AC			Tapping screw
6-19	XTTS740P12000	AC			Tapping screw
6-20	XTTS740P14000	AC			Tapping screw
6-21	XTTS740P16000	AC			Tapping screw
6-23	XWSS700-25000	AC			Spring washer
6-24	XTTS740P10000	AC			Tapping screw

[9] CV-P10LC (Control box parts)

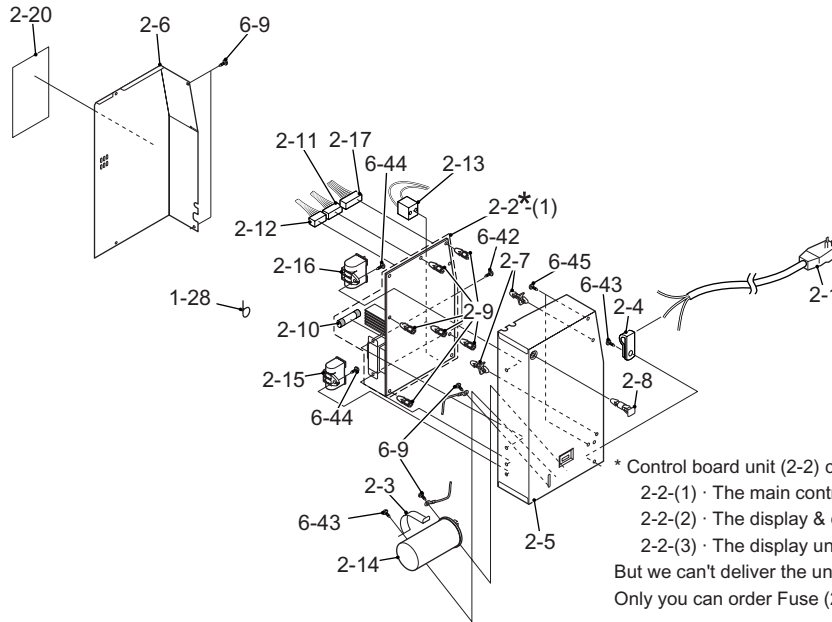

* Control board unit (2-2) consists of three units.
 2-2-(1) · The main control unit with Fuse (2-10).
 2-2-(2) · The display & detector unit.
 2-2-(3) · The display unit for the cluster.
 But we can't deliver the units separately.
 Only you can order Fuse (2-10).

NO.	PARTS CODE	PRICE RANK	NEW MARK	PART RANK	DESCRIPTION
[9] CV-P10LC (Control box parts)					
1-28	LBND-A042JBE0	AC			Wire fixing band
2-1	CACC-A030JBKZ	BM			Pack ass'y
2-2	DPWBFA484JBKZ	BT			Control board unit
2-3	LBNDKA130JBWZ	AK			Capacitor clamp
2-4	LHLDW0366JBE0	AA			Wire holder
2-5	PBOX-A450JBWZ	AS			Control box
2-6	PCOV-B126JBWZ	AP			Control box cover
2-7	PSPA-A146JBE0	AC			Spacer
2-8	PSPA-A177JBZZ	AE			PWB spacer
2-9	PSPA-A178JBZZ	AE			PWB spacer
2-10	QFS-AA048JBE0	AB			Fuse
2-11	QW-VZF465JBZZ	--			Lead wire
2-12	QW-VZF466JBZZ	--			Lead wire
2-13	QW-VZE999JBZZ	AK			Lead wire
2-14	RC-HZA484JBZZ	AY			Running capacitor
2-15	RC-HZA509JBZZ	AP			Fan motor capacitor
2-16	RC-HZA529JBZZ	AR			Fan motor capacitor
2-17	RH-HXA047JBZZ	AV			Thermistor
2-20	TLABCC034JBRZ	AD			Wiring diagram
6-9	XHTS740P08000	AC			Tap tight screw (for earth leads & Control box)
6-42	XJTS740P08000	AC			Tap tight screw (for the transformer)
6-43	XJTS740P10000	AC			Tap tight screw (for Running capacitor & Wire holder)
6-44	XJTS740P12000	AC			Tap tight screw (for Fan motor capacitor)
6-45	XTPS740P10000	AC			Tapping screw (for Control box ass'y)

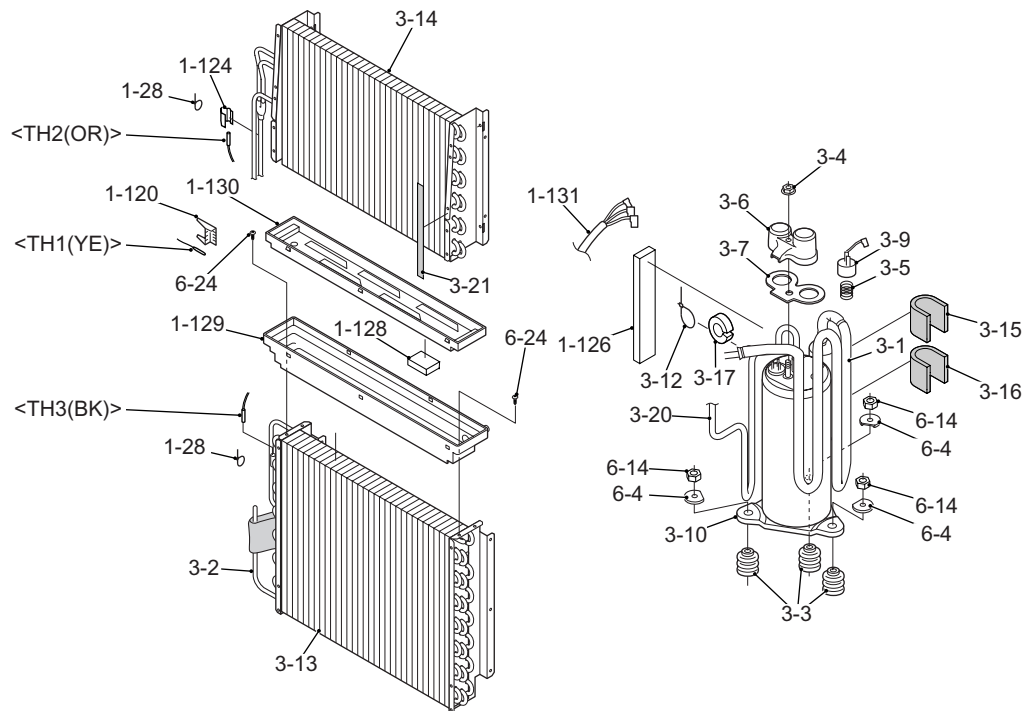
[10] CV-P10LC (Cycle parts)

NO.	PARTS CODE	PRICE RANK	NEW MARK	PART RANK	DESCRIPTION
[10] CV-P10LC (Cycle parts)					
1-28	LBND-A042JBE0	AC			Wire fixing band
1-120	LHLD-A315JBF0	AE			Thermistor holder
1-124	MSPR-A027JBE0	AB			Thermistor spring
1-126	PCOV-B154JBEZ	AG			Cover M
1-128	PSEL-C882JBEZ	AC			Drain pan insulator
1-129	PSRA-A174JBFZ	AZ			Dribbler
1-130	PSRA-A173JBFZ	AX			Drain pan
1-131	QW-IZA083JBZZ	AP			Comp wiring
3-1	CPIPCA929JBKZ	AX			Suction tube ass'y
3-2	DCPY-A340JBKZ	AR			Capillary tube ass'y
3-3	GLEG-A103JBE0	AG			Compressor cushion
3-4	LX-NZA148JBE0	AD			Frangle nut
3-5	MSPR-A114JBE0	AF			Protector spring
3-6	PCOV-A371JBE0	AF			Terminal cover
3-7	PSEL-B160JBE0	AH			Terminal gasket
3-9	RHOG-A233JBEZ	AU			Overload relay
3-10	PCMPRA468JBEZ	CA			Compressor
3-12	LBND-A046JBE0	AE			Wire fixing band
3-13	PCON-A569JBEZ	BT			Condenser
3-14	PEVA-A586JBEZ	BQ			Evaporator
3-15	PFPFPC834JBEZ	AD			Insulator A
3-16	PFPFPC835JBEZ	AD			Insulator B
3-17	PGUM-A113JBE0	AH			Damper rubber
3-20	PPIPCH210JB1Z	AP			Discharge tube
3-21	PSEL-C880JBEZ	AC			Eva insulator
6-4	LX-WZA047JBEZ	AC			Comp.washer
6-14	XNES780-65000	AC			Nut
6-24	XTTS740P10000	AC			Tapping screw

[11] CV-P10LC (Accessory parts)

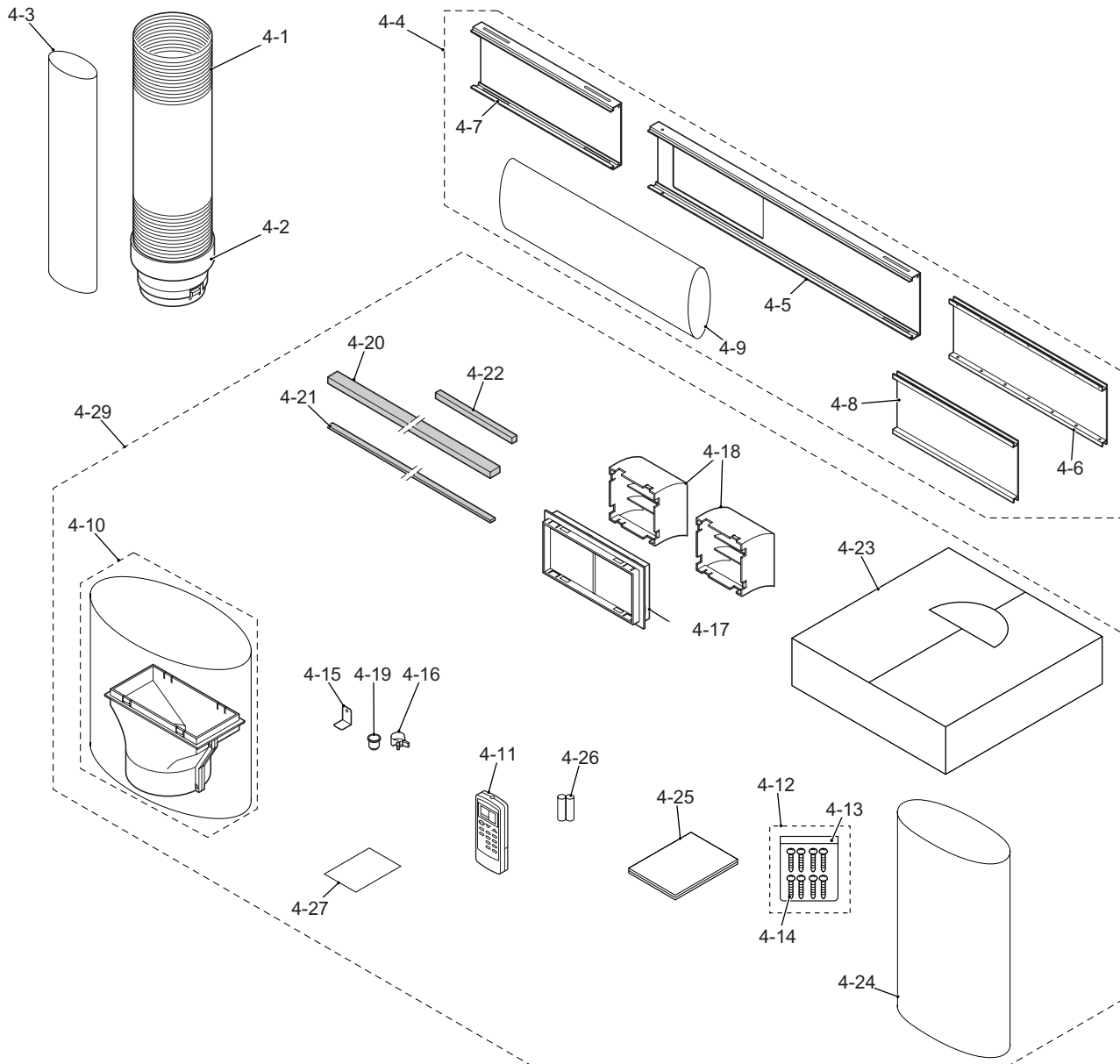

NO.	PARTS CODE	PRICE RANK	NEW MARK	PART RANK	DESCRIPTION
[11] CV-P10LC (Accessory parts)					
4-1	PDUC-A011JBFB	BC			Duct hose
4-2	PJNT-A007JBFB	AH			Connector C
4-3	SSAKAA109JBEZ	AE			Bag
4-4	CPNL-A528JBKZ	BD			Window panel ass'y
4-5	PPNLCA011JBEB	AW			Window panel A
4-6	PPNLCA012JBEB	AP			Window panel B
4-7	PPNLCA013JBEB	AP			Window panel C
4-8	PPNLCA014JBEB	AL			Panel cover
4-9	SSAKAA111JBEZ	AE			Bag
4-10	CJNT-A003JBKZ	AZ			Connector ass'y
4-11	CRMC-A705JBEZ	BC			Remote controller
4-12	DX-BZA049JBKZ	AS			Screw kit
4-13	SSAKAA018YDE0	AB			Bag
4-14	XMP5740P25000	AC			Wood screw
4-15	LANG-A616JBTA	AK			Panel angle
4-16	LBNDKA136JBEZ	AF			Band 5/8
4-17	LHLD-A740JBFA	AQ			Holder
4-18	PCOV-B115JBFA	AG			Cover
4-19	PGUMMA347JBEZ	AE			Drain joint
4-20	PSEL-A931JBE0	AH			Window insulator
4-21	PSEL-C848JBEZ	AD			Panel insulator
4-22	PSEL-C881JBEZ	AC			Panel insulator
4-23	SPAKCB932JBEZ	AH			Accessory case
4-24	SSAKHA149YDE0	AC			Bag

NO.	PARTS CODE	PRICE RANK	NEW MARK	PART RANK	DESCRIPTION
[11] CV-P10LC (Accessory parts)					
4-25	TINSEA467JBRZ	AN			Operation manual
4-26	UBATUA027JBE0	AE			Battery pack
4-27	TLAB-C979JBRZ	AF			Caution label
4-29	DFZK-B643JBKZ	BL			Accessory sub kit

[12] CV-P10LC (Packing parts)

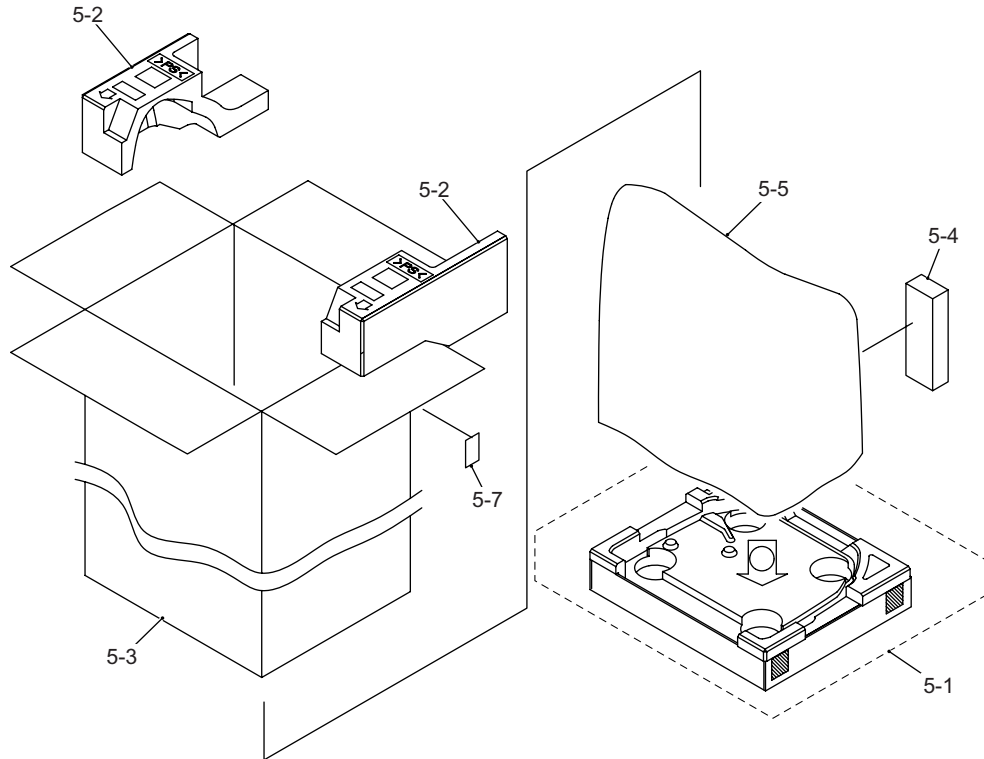

NO.	PARTS CODE	PRICE RANK	NEW MARK	PART RANK	DESCRIPTION
[12] CV-P10LC (Packing parts)					
5-1	CPADBA114JBKZ	AF			Bottom pad ass'y
5-2	CPADBA111JBKZ	AR			Top pad ass'y
5-3	DPAKCA007JBKZ	AZ			Packing case ass'y
5-4	SPADBA321JBEZ	AD			Pad
5-5	SSAKHA018JBEZ	AF			Bag
5-7	TLABKE117JBRZ	AF			Number card

INDEX

PARTS CODE	No.	PRICE RANK	NEW MARK	PART RANK
[C]				
CACC-A030JBKZ	3-2-1	BM		
"	9-2-1	BM		
CCAB-A421JBKZ	1-1-1	BH		
CCAB-A422JBKZ	7-1-1	BH		
CCHS-A914JBKZ	2-1-8	AZ		
"	8-1-8	AZ		
CFLO-A001JBKZ	2-1-108	AK		
"	8-1-108	AK		
CGUM-A001JBKZ	2-1-14	--		
"	8-1-14	--		
CJNT-A001JBKZ	5-4-10	AZ		
CJNT-A003JBKZ	11-4-10	AZ		
CKES-A162JBKZ	2-1-17	AT		
"	8-1-17	AT		
CKITTA069AKKZ	1-1-55	BD		
"	7-1-55	BD		
CMOT-A439JBKZ	2-1-88	BL		
"	8-1-88	BL		
CMOT-A440JBKZ	2-1-100	BG		
"	8-1-100	BG		
CPADBA111JBKZ	6-5-2	AR		
"	12-5-2	AR		
CPADBA114JBKZ	6-5-1	AF		
"	12-5-1	AF		
CPIPCA929JBKZ	4-3-1	AX		
"	10-3-1	AX		
CPMP-A005JBKZ	2-1-27	AN		
"	8-1-27	AN		
CPNL-A518JBKZ	5-4-4	BD		
CPNL-A528JBKZ	11-4-4	BD		
CPNL-A553JBKZ	1-1-36	BH		
CPNL-A554JBKZ	7-1-36	BH		
CRMC-A663JBEZ	5-4-11	AY		
CRMC-A705JBEZ	11-4-11	BC		
CVLV-A755JBKZ	2-1-44	BE		
"	8-1-44	BE		
[D]				
DANG-A049JBKZ	2-1-82	AZ		
"	8-1-82	AZ		
DCHS-A536JBTA	2-1-9	BB		
"	8-1-9	BB		
DCPY-A340JBKZ	4-3-2	AR		
"	10-3-2	AR		
DFILMA001JBEA	1-1-83	AM		
DFILMA001JBEC	7-1-83	AR		
DFILMA002JBEA	1-1-84	AM		
DFILMA002JBEC	7-1-84	AS		
DFZK-B641JBKZ	5-4-29	BL		
DFZK-B643JBKZ	11-4-29	BL		
DLOV-A013JBKZ	1-1-56	AZ		
DLOV-A016JBKZ	7-1-56	AS		
DPAKCA005JBKZ	6-5-3	AZ		
DPAKCA007JBKZ	12-5-3	AZ		
DPLT-A074JBKZ	2-1-85	AV		
"	8-1-85	AV		
DPLT-A075JBKZ	2-1-86	AX		
"	8-1-86	AX		
DPLT-A076JBKZ	2-1-87	AZ		
"	8-1-87	AZ		
DPWBFA395JBKZ	2-2-19	AS		
"	8-2-19	AS		
DPWBFA484JBKZ	3-2-2	BT		
"	9-2-2	BT		
DSW-MA003JBKZ	2-1-107	AS		
"	8-1-107	AS		
DX-BZA049JBKZ	5-4-12	AS		
"	11-4-12	AS		
[G]				
GCAB-A292JBFA	1-1-2	BL		
GCAB-A292JBFC	7-1-2	BG		
GLEG-A103JBE0	4-3-3	AG		
"	10-3-3	AG		
GWAKPA173JBFA	1-1-59	BC		
"	7-1-59	BC		
[H]				
HBDG-A002KKEA	1-1-37	AE		
"	7-1-37	AE		
HDEC-B192JBFA	1-1-38	AF		

PARTS CODE	No.	PRICE RANK	NEW MARK	PART RANK
"	7-1-38	AF		
HPNL-A726JBFA	1-1-39	AW		
HPNL-A726JBFC	7-1-39	AR		
HPNL-A727JBFA	1-1-40	AZ		
"	7-1-40	AZ		
HPNL-A728JBFA	1-1-115	AW		
HPNL-A728JBFC	7-1-115	AU		
HPNL-A729JBFA	1-1-116	AW		
HPNL-A729JBFC	7-1-116	AU		
HPNL-A815JBRA	1-1-41	BC		
HPNL-A815JBRB	7-1-41	BC		
[L]				
LANG-A606JBFBZ	2-1-102	AM		
"	8-1-102	AM		
LANG-A613JBWBZ	2-1-117	AR		
"	8-1-117	AR		
LANG-A614JBFBZ	2-1-103	AK		
"	8-1-103	AK		
LANG-A615JBWBZ	2-1-45	AK		
"	8-1-45	AK		
LANG-A616JBTA	5-4-15	AK		
"	11-4-15	AK		
LANG-A617JBWBZ	2-1-90	AL		
"	8-1-90	AL		
LANG-A618JBFBZ	2-1-104	AK		
"	8-1-104	AK		
LANG-A623JBFBZ	1-1-60	AG		
"	7-1-60	AG		
LBND-A042JBE0	2-1-28	AC		
"	3-1-28	AC		
"	4-1-28	AC		
"	8-1-28	AC		
"	9-1-28	AC		
"	10-1-28	AC		
LBND-A046JBE0	4-3-12	AE		
"	10-3-12	AE		
LBNDKA130JBWBZ	3-2-3	AK		
"	9-2-3	AK		
LBNDKA132JBEZ	2-1-29	AE		
"	8-1-29	AE		
LBNDKA136JBEZ	5-4-16	AF		
"	11-4-16	AF		
LHLD-A315JBFB0	4-1-120	AE		
"	10-1-120	AE		
LHLD-A735JBFA	1-1-3	AD		
LHLD-A735JBFB	7-1-3	AD		
LHLD-A737JBFA	1-1-61	AZ		
"	7-1-61	AZ		
LHLD-A739JBFA	2-1-111	AZ		
"	8-1-111	AZ		
LHLD-A740JBFA	5-4-17	AQ		
"	11-4-17	AQ		
LHLDW0364JBE0	2-1-91	AA		
"	8-1-91	AA		
LHLDW0366JBE0	2-1-122	AA		
"	3-2-4	AA		
"	8-1-122	AA		
"	9-2-4	AA		
LHLDW0368JBE0	2-1-123	AA		
"	8-1-123	AA		
LHLDW0370JBE0	2-1-92	AA		
"	8-1-92	AA		
LHLDWA042JBEZ	2-1-121	AE		
"	8-1-121	AE		
LPLTMA207JBWBZ	2-1-53	AL		
"	8-1-53	AL		
LPLTMA210JBWBZ	2-1-48	AQ		
"	8-1-48	AQ		
LPLTMA211JBWBZ	2-1-51	AQ		
"	8-1-51	AQ		
LSTP-A027JBFA	1-1-62	AM		
"	7-1-62	AM		
LX-BZA360JBEZ	2-6-2	AF		
"	8-6-2	AF		
LX-NZA148JBE0	4-3-4	AD		
"	10-3-4	AD		
LX-NZA316JBEZ	2-6-3	AF		
"	8-6-3	AF		
LX-WZA047JBEZ	4-6-4	AC		
"	10-6-4	AC		

PARTS CODE	No.	PRICE RANK	NEW MARK	PART RANK
LX-WZA048JBEZ	2-6-5	AD		
"	8-6-5	AD		
[M]				
MJNT-A023JBFA	2-1-18	AF		
"	8-1-18	AF		
MLOV-A409JBFA	2-1-19	AF		
"	8-1-19	AF		
MLOV-A410JBFA	2-1-20	AF		
"	8-1-20	AF		
MLOV-A411JBFA	1-1-63	AF		
MLOV-A411JBFB	7-1-63	AN		
MLOV-A412JBFA	1-1-58	AF		
MLOV-A412JBFB	7-1-58	AN		
MLOV-A413JBFA	1-1-57	AF		
MLOV-A413JBFB	7-1-57	AK		
MSPR-A027JBE0	4-1-124	AB		
"	10-1-124	AB		
MSPR-A114JBE0	4-3-5	AF		
"	10-3-5	AF		
[N]				
NFANSA045JBFZ	2-1-89	AX		
"	8-1-89	AX		
NFANSA049JBFZ	2-1-101	AV		
"	8-1-101	AV		
NKOM-A001JBEZ	2-1-10	AG		
"	8-1-10	AG		
[P]				
PBOX-A450JBWZ	3-2-5	AS		
"	9-2-5	AS		
PCMPRA468JBEZ	4-3-10	CA		
"	10-3-10	CA		
PCON-A569JBEZ	4-3-13	BT		
"	10-3-13	BT		
PCOV-A371JBE0	4-3-6	AF		
"	10-3-6	AF		
PCOV-B105JBFZ	2-2-18	AG		
"	8-2-18	AG		
PCOV-B108JBFA	1-1-64	AZ		
"	7-1-64	AZ		
PCOV-B112JBFZ	2-1-112	AF		
"	8-1-112	AF		
PCOV-B115JBFA	5-4-18	AG		
"	11-4-18	AG		
PCOV-B126JBWZ	3-2-6	AP		
"	9-2-6	AP		
PCOV-B154JBEZ	4-1-126	AG		
"	10-1-126	AG		
PCOV-B297JBEZ	2-1-46	AK		
"	8-1-46	AK		
PCOV-B298JBEZ	2-1-50	AK		
"	8-1-50	AK		
PCOV-B299JBEZ	2-1-52	AN		
"	8-1-52	AN		
PCOV-B300JBEZ	2-1-54	AN		
"	8-1-54	AN		
PDUC-A011JBFA	5-4-1	AZ		
PDUC-A011JBFB	11-4-1	BC		
PEVA-A586JBEZ	4-3-14	BQ		
"	10-3-14	BQ		
PFLO-A006JBFZ	2-1-113	AE		
"	8-1-113	AE		
PFPFPC765JBEZ	2-1-21	AE		
"	8-1-21	AE		
PFPFPC769JBFZ	1-1-65	AF		
"	7-1-65	AF		
PFPFPC770JBFZ	1-1-66	AF		
"	7-1-66	AF		
PFPFPC771JBEZ	1-1-67	AF		
"	7-1-67	AF		
PFPFPC772JBEZ	1-1-68	AF		
"	7-1-68	AF		
PFPFPC773JBEZ	1-1-69	AF		
"	7-1-69	AF		
PFPFPC774JBEZ	1-1-70	AF		
"	7-1-70	AF		
PFPFPC775JBEZ	1-1-71	AF		
"	7-1-71	AF		
PFPFPC826JBEZ	2-1-22	AC		
"	8-1-22	AC		
PFPFPC827JBEZ	2-1-23	AC		
"	8-1-23	AC		
PFPFPC828JBEZ	2-1-24	AC		

PARTS CODE	No.	PRICE RANK	NEW MARK	PART RANK
"	8-1-24	AC		
PFPFPC829JBEZ	2-1-25	AC		
"	8-1-25	AC		
PFPFPC830JBEZ	1-1-72	AC		
"	7-1-72	AC		
PFPFPC831JBEZ	1-1-73	AC		
"	7-1-73	AC		
PFPFPC832JBEZ	1-1-74	AC		
"	7-1-74	AC		
PFPFPC834JBEZ	4-3-15	AD		
"	10-3-15	AD		
PFPFPC835JBEZ	4-3-16	AD		
"	10-3-16	AD		
PFPFPC862JBEZ	1-1-75	AC		
"	7-1-75	AC		
PGID-A124JBFA	1-1-42	AF		
PGID-A124JBFC	7-1-42	AK		
PGID-A125JBFA	1-1-43	AF		
PGID-A125JBFC	7-1-43	AK		
PGUM-A113JBE0	4-3-17	AH		
"	10-3-17	AH		
PGUM-A164JBEZ	2-1-11	AE		
"	8-1-11	AE		
PGUM-A165JBEZ	2-1-12	AE		
"	8-1-12	AE		
PGUM-A166JBEZ	2-1-13	AE		
"	8-1-13	AE		
PGUMMA347JBEZ	5-4-19	AE		
"	11-4-19	AE		
PHOS-A045JBEZ	2-1-34	AM		
"	8-1-34	AM		
PJNT-A007JBFA	5-4-2	AH		
PJNT-A007JBFB	11-4-2	AH		
PKESSA090JBFA	2-1-26	AX		
"	8-1-26	AX		
PKESSA091JBFZ	2-1-106	AX		
"	8-1-106	AX		
PKESSA092JBFA	2-1-97	AX		
"	8-1-97	AX		
PKESSA093JBFA	2-1-98	AX		
"	8-1-98	AX		
PKESSA094JBFA	2-1-99	AX		
"	8-1-99	AX		
PPIPCH210JBIZ	4-3-20	AP		
"	10-3-20	AP		
PPNLCA011JBEA	5-4-5	AW		
PPNLCA011JBEB	11-4-5	AW		
PPNLCA012JBEA	5-4-6	AP		
PPNLCA012JBEB	11-4-6	AP		
PPNLCA013JBEA	5-4-7	AP		
PPNLCA013JBEB	11-4-7	AP		
PPNLCA014JBEA	5-4-8	AL		
PPNLCA014JBEB	11-4-8	AL		
PSEL-A931JBE0	5-4-20	AH		
"	11-4-20	AH		
PSEL-B160JBE0	4-3-7	AH		
"	10-3-7	AH		
PSEL-C848JBEZ	5-4-21	AD		
"	11-4-21	AD		
PSEL-C875JBEZ	2-1-15	AC		
"	8-1-15	AC		
PSEL-C876JBEZ	1-1-76	AC		
"	7-1-76	AC		
PSEL-C877JBEZ	1-1-77	AC		
"	7-1-77	AC		
PSEL-C879JBEZ	1-1-78	AC		
"	7-1-78	AC		
PSEL-C880JBEZ	4-3-21	AC		
"	10-3-21	AC		
PSEL-C881JBEZ	5-4-22	AC		
"	11-4-22	AC		
PSEL-C882JBEZ	4-1-128	AC		
"	10-1-128	AC		
PSHE-A230JBEZ	2-2-21	AF		
"	8-2-21	AF		
PSPA-A146JBE0	3-2-7	AC		
"	9-2-7	AC		
PSPA-A177JBZZ	3-2-8	AE		
"	9-2-8	AE		
PSPA-A178JBZZ	3-2-9	AE		
"	9-2-9	AE		
PSPRCA018JBEZ	1-1-79	AF		

CVP09LX

PARTS CODE	No.	PRICE RANK	NEW MARK	PART RANK
"	7-1-79	AF		
PSRA-A172JBFA	2-1-16	AX		
"	8-1-16	AX		
PSRA-A173JBFZ	4-1-130	AX		
"	10-1-130	AX		
PSRA-A174JBFZ	4-1-129	AZ		
"	10-1-129	AZ		
[Q]				
QFS-AA048JBE0	3-2-10	AB		
"	9-2-10	AB		
QSW-MA009JBZZ	2-1-114	AL		
"	8-1-114	AL		
QW-IZA083JBZZ	4-1-131	AP		
"	10-1-131	AP		
QW-VZE999JBZZ	3-2-13	AK		
"	9-2-13	AK		
QW-VZF419JBZZ	1-1-80	AF		
"	7-1-80	AF		
QW-VZF465JBZZ	3-2-11	--		
"	9-2-11	--		
QW-VZF466JBZZ	3-2-12	--		
"	9-2-12	--		
[R]				
RC-HZA484JBZZ	3-2-14	AY		
"	9-2-14	AY		
RC-HZA509JBZZ	3-2-15	AP		
"	9-2-15	AP		
RC-HZA529JBZZ	3-2-16	AR		
"	9-2-16	AR		
RH-HXA047JBZZ	3-2-17	AV		
"	9-2-17	AV		
RHOG-A233JBEZ	4-3-9	AU		
"	10-3-9	AU		
RMOT-A061JBE0	1-1-81	AS		
"	7-1-81	AS		
[S]				
SPADBA321JBEZ	6-5-4	AD		
"	12-5-4	AD		
SPAKCB932JBEZ	5-4-23	AH		
"	11-4-23	AH		
SSAKAA018YDE0	5-4-13	AB		
"	11-4-13	AB		
SSAKAA109JBEZ	5-4-3	AE		
"	11-4-3	AE		
SSAKAA111JBEZ	5-4-9	AE		
"	11-4-9	AE		
SSAKHA018JBEZ	6-5-5	AF		
"	12-5-5	AF		
SSAKHA149YDE0	5-4-24	AC		
"	11-4-24	AC		
[T]				
TINSEA467JBRZ	5-4-25	AN		
"	11-4-25	AN		
TLAB-C973JBRZ	1-1-5	AF		
"	7-1-5	AF		
TLAB-C974JBRZ	1-1-6	AF		
"	7-1-6	AF		
TLAB-C975JBRZ	1-1-7	AF		
"	7-1-7	AF		
TLAB-C976JBRZ	1-1-8	AF		
"	7-1-8	AF		
TLAB-C977JBRZ	1-1-132	AF		
"	7-1-132	AF		
TLAB-C979JBRZ	5-4-27	AF		
"	11-4-27	AF		
TLAB-C989JBRZ	5-4-28	AF		
TLAB-C990JBRZ	1-1-4	AF		
"	1-1-137	AF		
"	7-1-4	AF		
"	7-1-137	AF		
TLABCC034JBRZ	3-2-20	AD		
"	9-2-20	AD		
TLABKE115JBRZ	6-5-7	AF		
TLABKE117JBRZ	12-5-7	AF		
TSPC-F428JBRZ	1-1-134	AK		
TSPC-F430JBRZ	7-1-134	AK		
[U]				
UBATUA027JBE0	5-4-26	AE		
"	11-4-26	AE		
[X]				
XCTS740P10000	2-6-8	AC		
"	8-6-8	AC		

PARTS CODE	No.	PRICE RANK	NEW MARK	PART RANK
XHTS740P08000	2-6-9	AC		
"	3-6-9	AC		
"	8-6-9	AC		
"	9-6-9	AC		
XJTS740P08000	3-6-42	AC		
"	9-6-42	AC		
XJTS740P10000	3-6-43	AC		
"	9-6-43	AC		
XJTS740P12000	3-6-44	AC		
"	9-6-44	AC		
XMPS740P25000	5-4-14	AC		
"	11-4-14	AC		
XNES780-65000	4-6-14	AC		
"	10-6-14	AC		
XTPS723P14000	2-6-15	AC		
"	8-6-15	AC		
XTPS730P10000	1-6-16	AC		
"	7-6-16	AC		
XTPS740P10000	3-6-45	AC		
"	9-6-45	AC		
XTPS740P12000	2-6-17	AC		
"	8-6-17	AC		
XTTS740P10000	1-6-24	AC		
"	2-6-24	AC		
"	4-6-24	AC		
"	7-6-24	AC		
"	8-6-24	AC		
"	10-6-24	AC		
XTTS740P12000	1-6-19	AC		
"	2-6-19	AC		
"	7-6-19	AC		
"	8-6-19	AC		
XTTS740P14000	2-6-20	AC		
"	8-6-20	AC		
XTTS740P16000	2-6-21	AC		
"	8-6-21	AC		
XUPS740P08000	1-6-22	AC		
"	7-6-22	AC		
XWSS700-25000	2-6-23	AC		
"	8-6-23	AC		

MEMO

SHARP

COPYRIGHT © 2006 BY SHARP CORPORATION

ALL RIGHTS RESERVED.

No part of this publication may be reproduced, stored in retrieval systems, or transmitted in any form or by any means, electronic, mechanical, photocopying, recording, or otherwise, without prior written permission of the publisher.

SHARP CORPORATION
Appliance Systems Group
Quality Assurance Department