

First in Cooking, Built to Last.

**southbend**

A MIDDLEBY COMPANY

**IMPORTANT FOR FUTURE REFERENCE**

Please complete this information and retain this manual for the life of the equipment:

Model #: \_\_\_\_\_

Serial #: \_\_\_\_\_

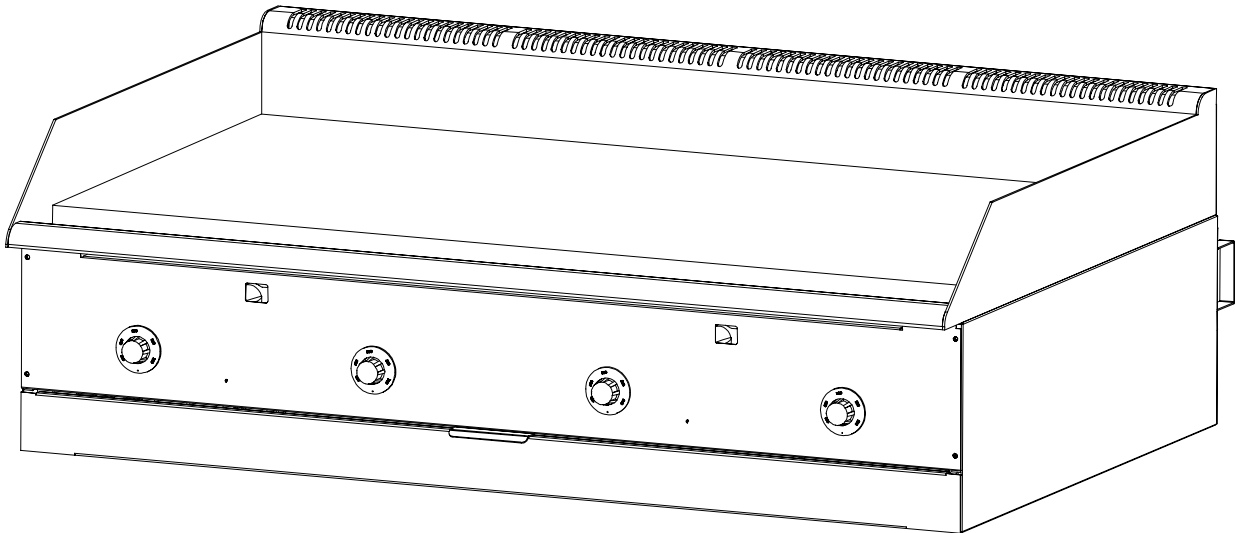
Date Purchased: \_\_\_\_\_

# OPERATOR'S MANUAL

# Counter Griddle

## Model Numbers

- |        |         |
|--------|---------|
| SGS-24 | SGS-24E |
| SGS-36 | SGS-36E |
| SGS-48 | SGS-48E |
| SGS-60 | SGS-60E |



Model SGS-48 Shown

**! WARNING**

Improper installation, adjustment, alteration, service or maintenance can cause property damage, injury or death. Read the installation, operating and maintenance instructions thoroughly before installing or servicing this equipment.

1100 Old Honeycutt Road, Fuquay-Varina, NC 27526  
(800) 348-2558 or (919) 552-9161 • FAX (800) 348-2558 or (919) 552-9798



# SAFETY PRECAUTIONS

Before installing and operating this equipment, be sure everyone involved in its operation is fully trained and aware of precautions. Accidents and problems can be caused by failure to follow fundamental rules and precautions.

The following symbols, found throughout this manual, alert you to potentially dangerous conditions to the operator, service personnel, or to the equipment.



This symbol warns of immediate hazards that will result in severe injury or death.



This symbol refers to a potential hazard or unsafe practice that could result in injury or death.



This symbol refers to a potential hazard or unsafe practice that could result in injury, product damage, or property damage.



This symbol refers to information that needs special attention or must be fully understood, even though not dangerous.

## **WARNING** **FIRE HAZARD** **FOR YOUR SAFETY**

Do not store or use gasoline or other flammable vapors and liquids in the vicinity of this or any other appliance.

Keep area around appliances free and clear of combustibles.

Purchaser of equipment must post in a prominent location, detailed instructions to be followed in the event the operator smells gas. Obtain the instructions from the local gas supplier.

## **WARNING**

Asphyxiation can result from improper ventilation. Do not obstruct the flow of combustion and ventilation air to and from your cooking equipment.

## **NOTICE**

Be sure this Operator's Manual and important papers are given to the proper authority to retain for future reference.

## **NOTICE**

This product is intended for commercial use only. NOT FOR HOUSEHOLD USE.

Congratulations! You have purchased one of the finest pieces of commercial cooking equipment on the market.

You will find that your new equipment, like all Southbend equipment, has been designed and manufactured to meet the toughest standards in the industry. Each piece of Southbend equipment is carefully engineered and designs are verified through laboratory tests and field installations. With proper care and field maintenance, you will experience years of reliable, trouble-free operation. **For best results, read this manual carefully.**

RETAIN THIS MANUAL FOR FUTURE REFERENCE.

## Table of Contents

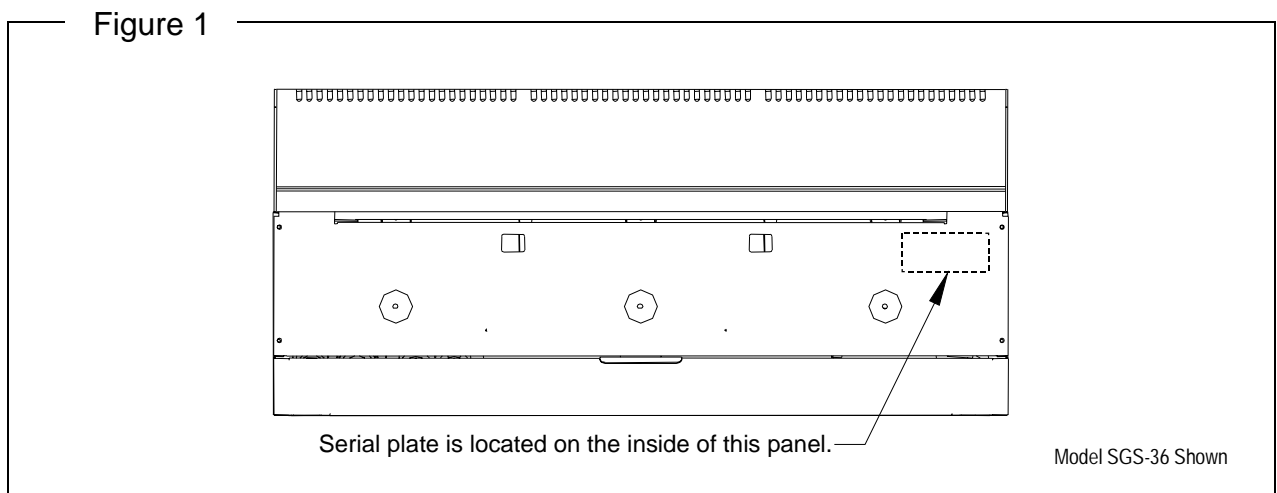
Specifications.....	4
Installation.....	7
Operation.....	19
Cleaning.....	21
Adjustments.....	22
Troubleshooting.....	26
Parts.....	27

Read these instructions carefully before attempting installation. Installation and initial startup should be performed by a qualified installer. Unless the installation instructions for this product are followed by a qualified service technician (a person experienced in and knowledgeable with the installation of commercial gas an/or electric cooking equipment) then the terms and conditions on the Manufacturer's Limited Warranty will be rendered void and no warranty of any kind shall apply.

In the event you have questions concerning the installation, use, care, or service of the product, write to:

Technical Service Department  
 Southbend  
 1100 Old Honeycutt Road  
 Fuquay-Varina, North Carolina 27526 USA

The serial plate is located on the interior side of the upper front panel, as shown below:





# SPECIFICATIONS

## NOTICE

Installation must comply with *National Fuel Gas Code, ANSI Z223.1, Natural Gas Installation Code, CAN/CGA-B149.1*, or the *Propane Installation Code, CAN/CGA-B149.2*, as applicable.

Local codes regarding installation vary greatly from one area to another. The National Fire Protection Association, Inc. states in its NFPA 96 latest edition that local codes are the “authority having jurisdiction” when it comes to installation requirements for equipment. Therefore, installations should comply with all local codes.

Southbend reserves the right to change specifications and product design without notice. Such revisions do not entitle the buyer to corresponding changes, additions, or replacements for previously purchased equipment.

This product is intended for commercial use only, not for household use.

## GAS SUPPLY

The Serial Plate is located on the interior side of the upper front panel (see Figure 1 on page 3). It indicates the type of gas (propane or natural gas) the griddle is equipped to burn. All Southbend equipment is adjusted at the factory. Check type of gas on serial plate.

This appliance should be connected **ONLY** to the type of gas for which it is configured.

An adequate gas supply is imperative. Undersized or low pressure lines will restrict the volume of gas required for satisfactory performance. Fluctuations of more than 25% on natural gas or 10% on propane gas will create problems and affect burner operating characteristics. A 1/8" pressure tap is located on the manifold to measure the manifold pressure.

No segment of the gas supply line to the griddle should be smaller than the inside diameter of the inlet connector of the griddle (3/4" NPT).

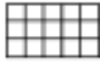
Purge the supply line to clean out dust, dirt, or other foreign matter before connecting the line to the griddle.

All pipe joints and connections must be tested thoroughly for gas leaks. Use only soapy water for testing on all gases. **NEVER** use an open flame to check for gas leaks. All connections must be checked for leaks after the griddle has been put into operation. Test pressure should not exceed 14" W.C.

## CAUTION

*THIS APPLIANCE AND ITS INDIVIDUAL SHUTOFF VALVE MUST BE DISCONNECTED FROM THE GAS SUPPLY PIPING SYSTEM DURING ANY PRESSURE TESTING OF THAT SYSTEM AT TEST PRESSURES IN EXCESS OF 1/2 PSIG (3.45 kPa).*

*THIS APPLIANCE MUST BE ISOLATED FROM THE GAS SUPPLY PIPING SYSTEM BY CLOSING ITS INDIVIDUAL MANUAL SHUTOFF VALVE DURING ANY PRESSURE TESTING OF THE GAS SUPPLY PIPING SYSTEM AT TEST PRESSURES EQUAL TO OR LESS THAN 1/2 PSIG (3.45 kPa).*



## CLEARANCES

### **WARNING**

There must be adequate clearance between griddles and adjacent construction. Clearance in the front must also be provided for servicing and for operation.

Minimum clearances from COMBUSTIBLE construction are 12" on sides, 8" on rear, and 4" on bottom (order the countertop legs or floor stand).

Minimum clearances from NON-COMBUSTIBLE construction is 0" on sides, 2" on rear (the 2" deep stand-offs on the rear may be against a wall), and 0" on the bottom.

## VENTILATION

### **WARNING**

Improper ventilation can result in personal injury or death. Ventilation which fails to properly remove flue products can cause headaches, drowsiness, nausea, or could result in death.

All griddles must be installed in such a manner that the flow of combustion and ventilation air are not obstructed. Provisions for adequate air supply must be provided. Do not obstruct the rear of the griddle as combustion air enters through this area.

### **NOTICE**

Proper ventilation is the owner's responsibility. Any problem due to improper ventilation will not be covered by the warranty.

Air for combustion enters the rear of the griddle. The exhaust flue runs along the top rear edge.

Southbend recommends that a ventilation canopy extend 6" past the edges of the griddle and be located 6'6" above the floor.

If a wall exhaust fan is installed in the wall behind the griddle, it should be at least two feet above the top of the flue opening along the back edge of the griddle.

To avoid a negative pressure condition, return air must be brought into the room to replenish the air being removed by the ventilation exhaust fan. **RETURN-AIR FANS MUST NOT BLOW DOWN INTO THE GRIDDLE FLUE (ALONG THE TOP REAR EDGE OF THE GRIDDLE), NOR DIRECTLY ONTO THE GRIDDLE SURFACE.**

Ventilation filters should be installed at an angle of 45° or more from the horizontal. This prevents dripping grease and facilitates collecting the run-off grease in a drip pan, usually installed with a filter.

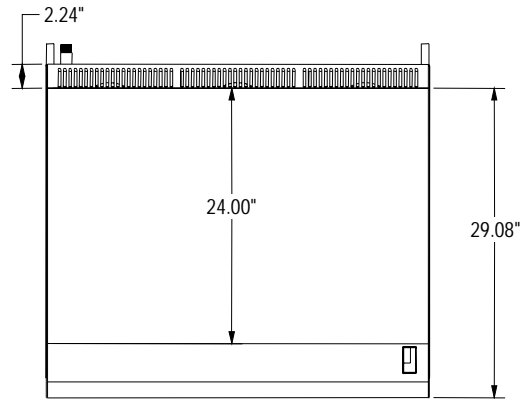
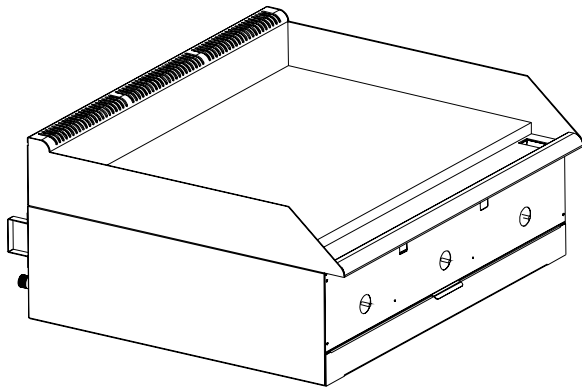
Be sure to inspect and clean the ventilation system according to the ventilation equipment manufacturer's instructions.

In case of unsatisfactory performance on any appliance, check the appliance with the ventilation exhaust fan in the "OFF" position. Do this only long enough to check equipment performance. Then turn the fan back on and let it run to remove any exhaust that may have accumulated during the test.

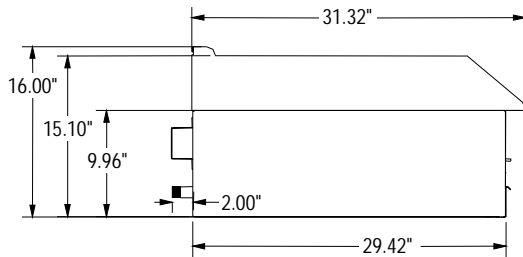


Figure 2

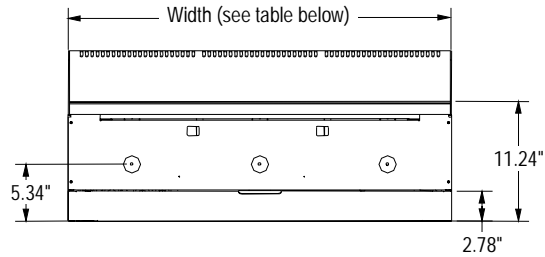
DIMENSIONS



Top View



Side View



Front View

Model	Width	Number and Size of Burners	Total BTU	Crate Size	Crated Weight
SGS-24 & SGS-24E	24"	2 @ 30,000	60,000	31"W x 39"D x 24"H	305 lbs.
SGS-36 & SGS-36E	36"	3 @ 30,000	90,000	55"W x 39"D x 24"H	445 lbs.
SGS-48 & SGS-48E	48"	4 @ 30,000	120,000	55"W x 39"D x 24"H	545 lbs.
SGS-60 & SGS-60E	60"	5 @ 30,000	150,000	67"W x 39"D x 24"H	705 lbs.

CONSTRUCTION

The front, sides, and 5" riser are all stainless steel. The rear and bottom panels are aluminized steel. The reinforced double-wall sides are fully insulated.

The griddle surface is high-carbon, 1" thick, polished steel plated with trivalent chromium. The chrome plate has an emissivity rating of approximately 0.08.

Each foot of griddle width is heated by a U-shaped burner controlled by a thermostatic gas valve for independent temperature control. Each pilot is equipped with a flame failure safety device.

The base of a 60" griddle consists of the base of a 24" griddle and a 36" griddle connected together, spanned by a 60" griddle surface with one grease duct and one grease drawer.



# INSTALLATION

## NOTICE

Installation must comply with *National Fuel Gas Code, ANSI Z223.1, Natural Gas Installation Code, CAN/CGA-B149.1*, or the *Propane Installation Code, CAN/CGA-B149.2*, as applicable.

These installation procedures must be followed by qualified personnel or warranty will be void.

Local codes regarding installation vary greatly from one area to another. The National Fire Protection Association, Inc. states in its NFPA 96 latest edition that local codes are the "authority having jurisdiction" when it comes to installation requirements for equipment. Therefore, installations should comply with all local codes.

INSTALLATION

## Step 1: Unpack

### IMMEDIATELY INSPECT FOR SHIPPING DAMAGE

All containers should be examined for damage before and during unloading. The freight carrier has assumed responsibility for its safe transit and delivery. If damaged equipment is received, either apparent or concealed, a claim must be made with the delivering carrier.

Apparent damage or loss must be noted on the freight bill at the time of delivery. The freight bill must then be signed by the carrier representative (Driver). If the bill is not signed, the carrier may refuse the claim. The carrier can supply the necessary forms.

A request for inspection must be made to the carrier within 15 days if there is concealed damage or loss that is not apparent until after the equipment is uncrated. The carrier should arrange an inspection. Be certain to hold all contents plus all packing material.

1. Uncrate carefully. Report any hidden damage to the freight carrier IMMEDIATELY.
2. Do not remove any tags or labels until griddle is installed and working properly.

## Step 2: Attach Countertop Legs, Mount on Counter, or Mount on Stand

The counter griddle can be mounted in several ways:

To mount it on short, countertop legs, go to Step 2a on page 8.

To mount it directly on a countertop, go to Step 2b on page 9.

To mount it on an insulated base on a countertop, go to Step 2c on page 10.

To mount it on a stand that rests on the floor, go either to Step 2d on page 11 (for 24", 36", and 48" models) or to Step 2e on page 13 (for a 60" model).



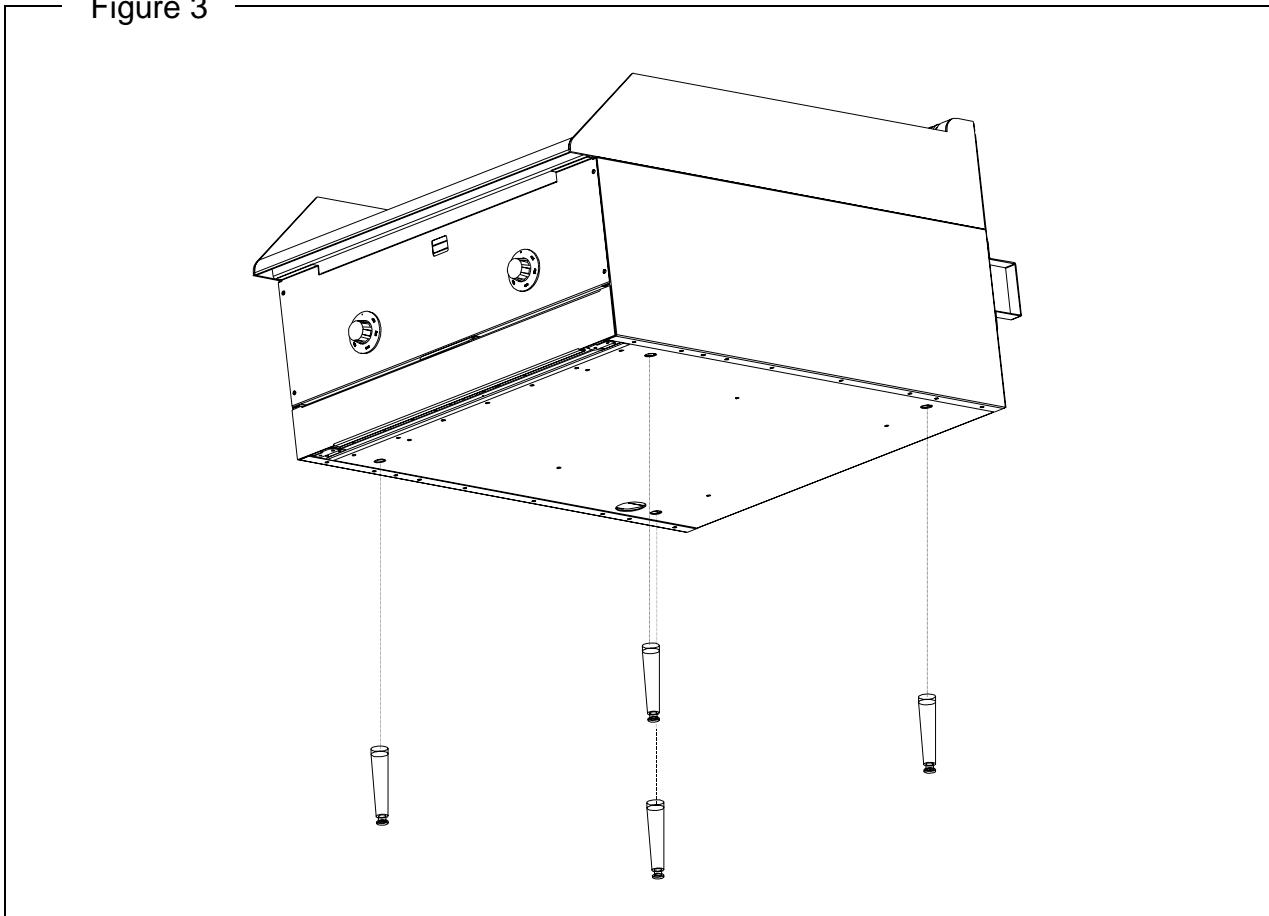
INSTALLATION

## Step 2a: Installation on Countertop Legs

To install the griddle using countertop legs, do the following:

1. Locate the box of four legs shipped with the griddle (if countertop legs were ordered).
2. Raise the griddle about 6" so that the legs can be screwed into the bottom near the corners. Lift the griddle only from the ends, never from the middle! Support the lifted griddle so that it will not fall while you are attaching the legs.
3. Screw the four legs into the threaded holes located on the bottom of the griddle near each corner (as shown in Figure 3 below).
4. Gently lower the griddle onto the counter. Level the griddle surface by screwing one or more of the legs in or out.
5. Go on to Step 4 on page 16.

Figure 3



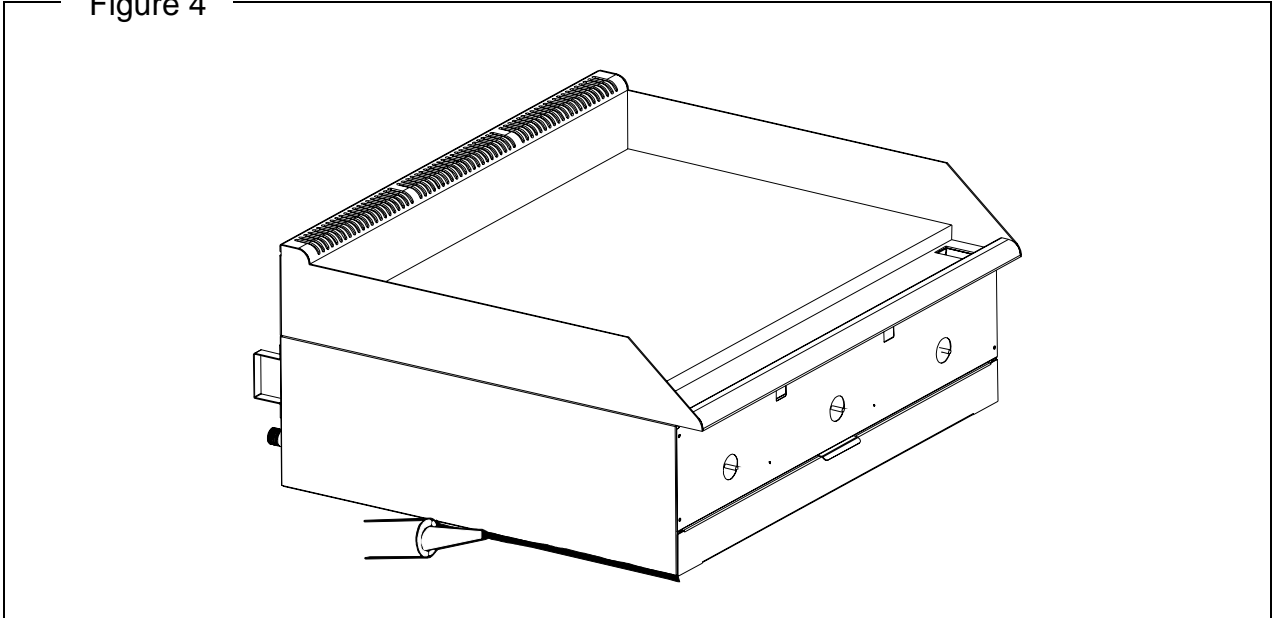


## Step 2b: Installation Directly on a Non-Combustible Countertop Surface

The griddle may be installed directly onto a flat NON-COMBUSTIBLE surface, as follows:

1. Place the griddle in the position that it will be used. Lift the griddle only from the ends, never from the middle!
2. Connect the gas supply (see Step 4 on page 16), then return to this procedure.
3. Check that the griddle is in the position you want it to be in.
4. Seal the griddle to the countertop using G.E. or Dow Corning RTV, or the equivalent (as shown in Figure 4 below). Consult local codes for exact requirements. A small bead of RTV around all four bottom edges should be adequate. Open the front door to seal along the front edge of the frame.
5. Go on to Step 5 on page 17.

Figure 4



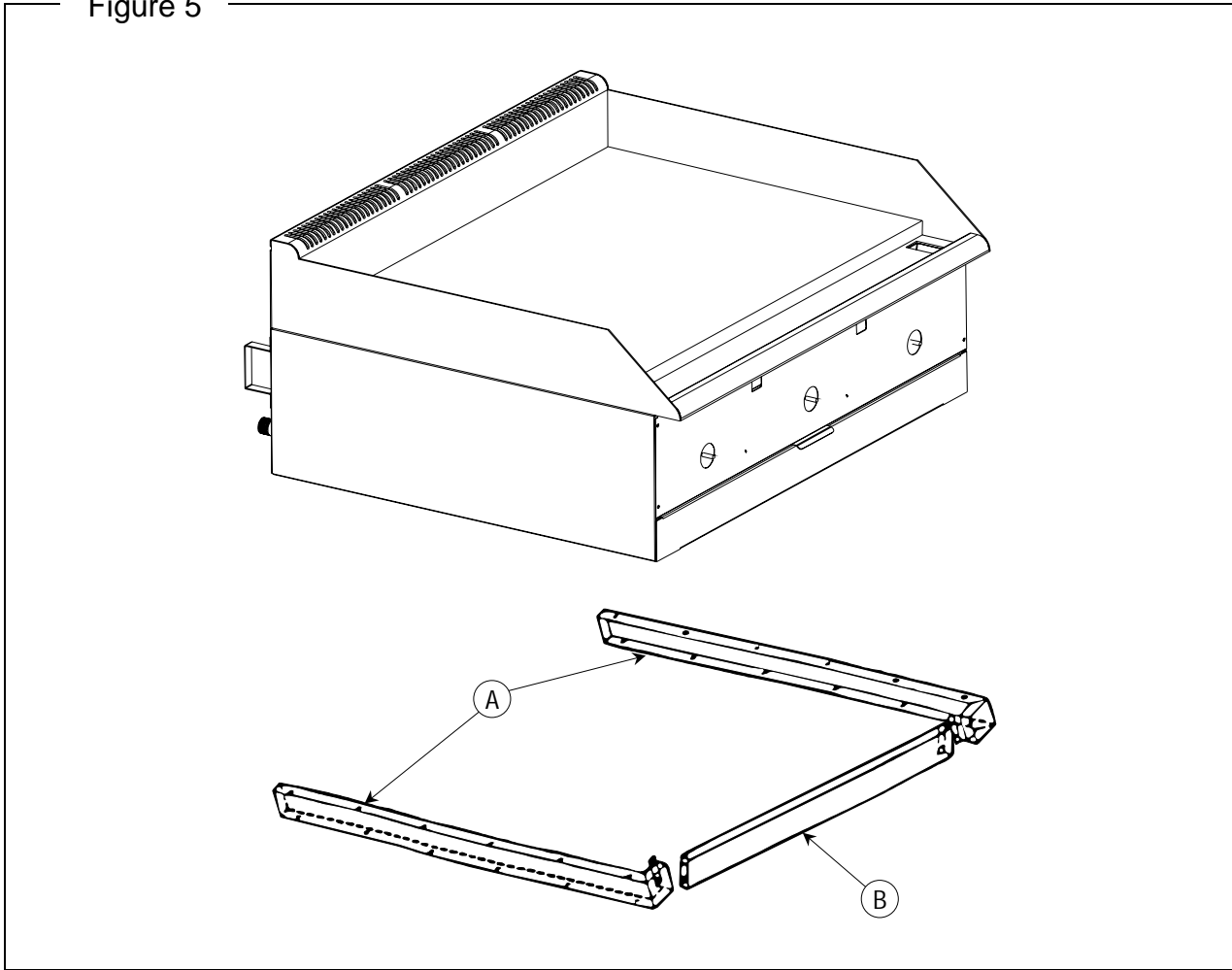


### Step 2c: Installation on Insulated Base

The griddle may be installed onto a flat NON-COMBUSTIBLE (but heat sensitive) surface using the optional insulated base, as follows:

1. Attach the side pieces of the insulated base (items "A" in Figure 5 below) to the front piece (item "B") using the four sheet metal screws provided.
2. Position the insulated base on the surface where you want the griddle to be located.
3. Position the griddle on top of the insulated base. Lift the griddle only from the ends, never from the middle!
4. Go on to Step 4 on page 16.

Figure 5



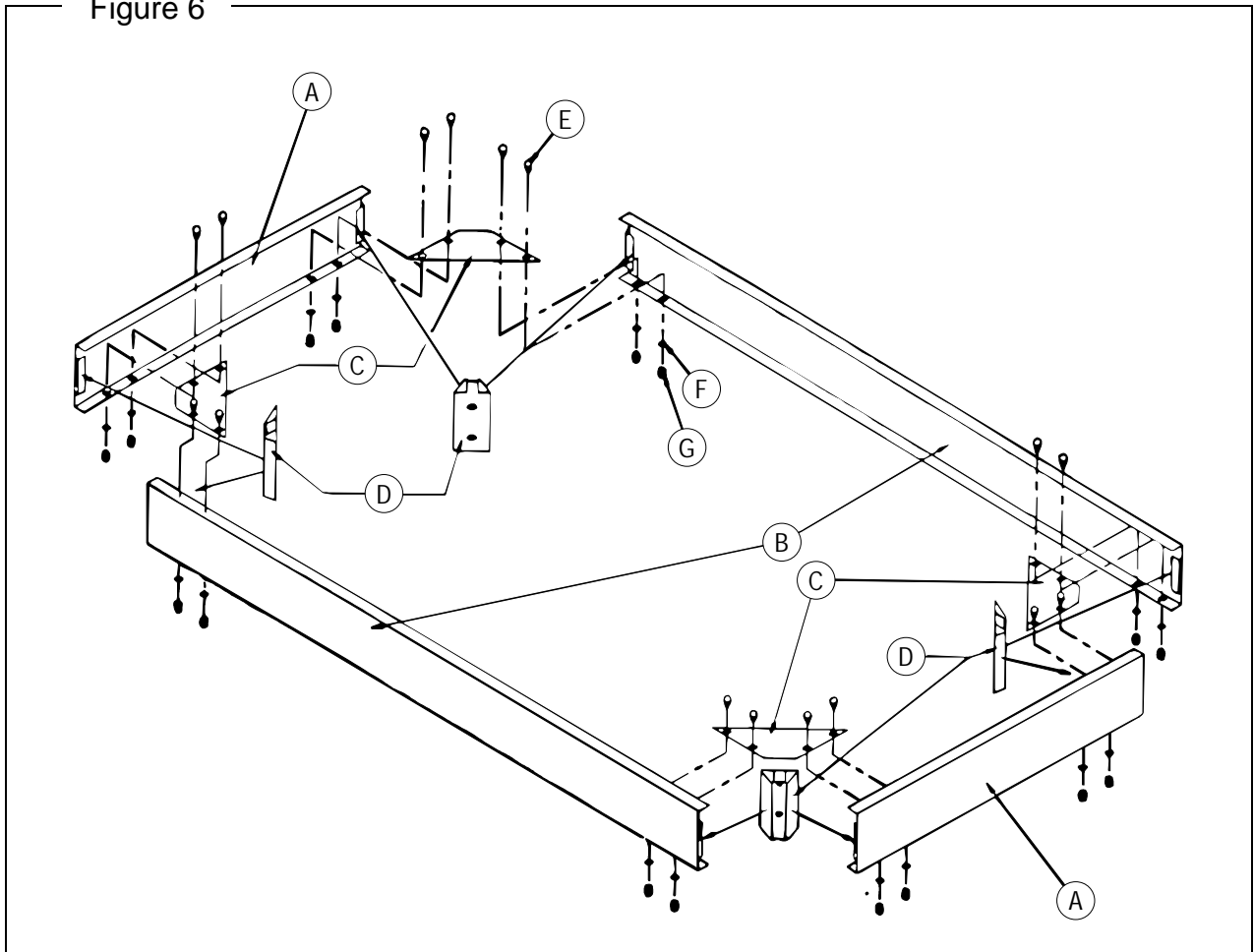


## Step 2d: Installation on Floor Stand (24", 36", and 48" Models)

The 24", 36", and 48" griddles may be installed on top of an optional floor stand (for 60" griddles, go to Step 2e on page 13). The floor stand is shipped in a separate crate and must be assembled, as follows:

1. Position the bottom-brace pieces on a flat surface, as shown in Figure 6 below. There are two bottom-side braces (items "A"), a bottom-front brace (item "B"), and an identical bottom-rear brace (item "B").
2. Position a corner brace (item "C") in each corner, matching the pre-punched holes on the lower inside flange of the bottom braces.
3. Position a leg bracket (item "D") into each corner. Be sure that the bracket flanges are engaged into the open hem of the bottom braces.
4. Use the sixteen 1/2"-long hex head bolts (items "E"), lock washers (items "F"), and acorn nuts (items "G") to bolt the corner braces to the bottom braces. Only hand-tighten for now.
5. Check that the leg brackets are in the proper position, and that the outside corners are square.

Figure 6

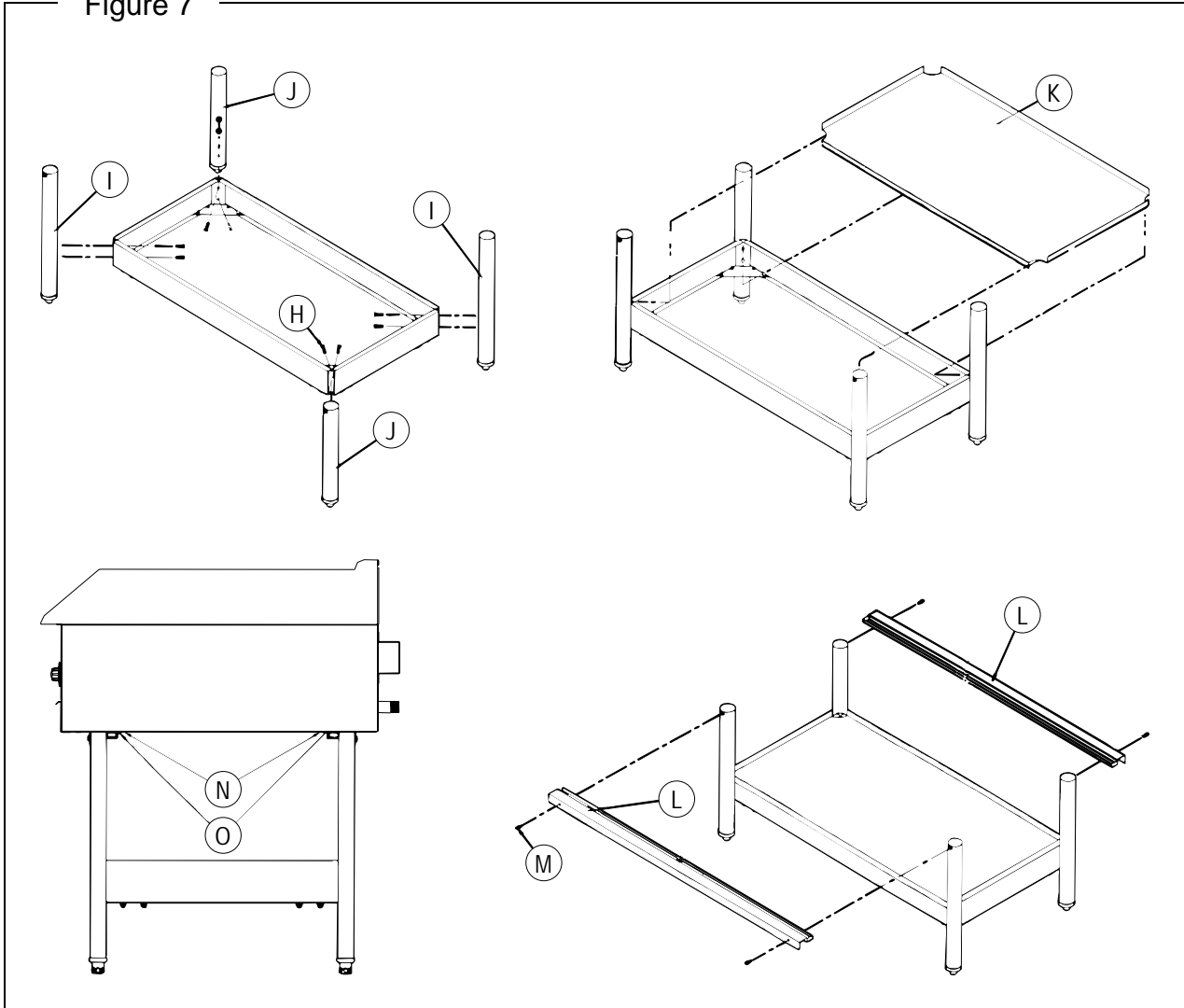


6. Use the eight 1-1/2" hex bolts (items "H" in Figure 7) to attach the two left-legs (items "I") and the two right-legs (items "J"). "Left" and "right" are as seen from the front or rear of the stand. Be sure that the small threaded-insert near the top of each leg faces either the front or the rear of the stand, not a side. Insert the bolts through the leg brackets and into the legs. Only hand-tighten the bolts for now.



Figure 7

INSTALLATION



7. Check the partially assembled stand to make sure that the legs are straight and that all corners are square. Now tighten all bolts, but do not over tighten.
8. If legs with casters were ordered, lift the stand and screw the caster assemblies into the bottom of the legs. The two casters with wheel-locks go on the front legs. **After the stand is assembled, be sure to connect the required restraint to protect the flexible gas connection (see Step 3 on page 15).**
9. If the optional shelf was ordered (item "K"), position it on top of the bottom braces. The down-flange edge of the shelf should be on the front side of the stand. The shelf simply rests on the bottom braces (it is not bolted or screwed to the braces).
10. Position the front and rear top supports (items "L") over the legs. The pre-drilled holes should face the outside of the stand to line up with the threaded-insert holes near the top of the legs. Use the four 5/8" hex-head bolts (items "M") to secure the top supports to the legs.
11. Attach the angle support brackets (item "N", shipped with the griddle) to the bottom of the of the griddle using #10x1/2" sheet metal screws (item "O", also shipped with the griddle).
12. Place the griddle on top of the stand, making sure that the angle brackets that you just installed on the bottom of the griddle are inserted into the front and rear top supports. No additional bolts or screws are required. **Lift the griddle only at the ends, never in the middle!**
13. Go on to Step 4 on page 16.

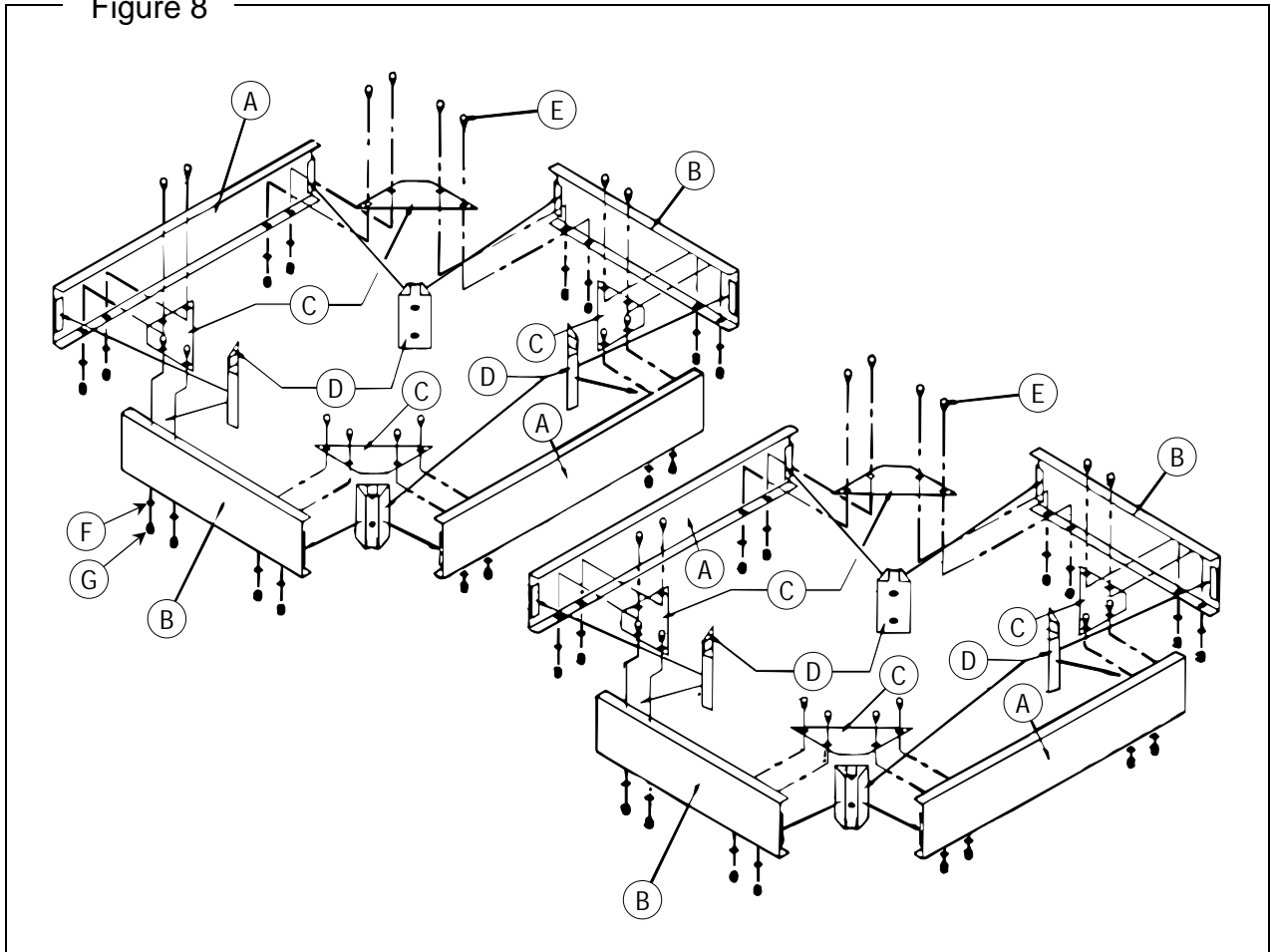


## Step 2e: Installation on Floor Stand (60" Models)

A 60" griddle may be installed on top of an optional floor stand (for 24", 36", and 48" griddles, go to Step 2d on page 11). The floor stand is shipped in a separate crate and must be assembled, as follows:

1. Position the bottom-brace pieces on a flat surface, as shown in Figure 8 below. There are four bottom-side braces (items "A"), and four front/rear bottom-braces (items "B").
2. Position a corner brace (item "C") in each interior corner, matching the pre-punched holes on the lower inside flange of the bottom braces.
3. Position the six leg brackets (item "D"); one in each corner of the stand, one front-center, and one rear-center, as shown in Figure 8. Be sure that the bracket flanges are engaged into the open hem of the bottom braces.
4. Use the thirty-two 1/2"-long hex head bolts (items "E"), lock washers (items "F"), and acorn nuts (items "G") to bolt the corner braces to the bottom braces. Only hand-tighten for now.
5. Check that the leg brackets are in the proper position, and that the outside corners are square.

Figure 8

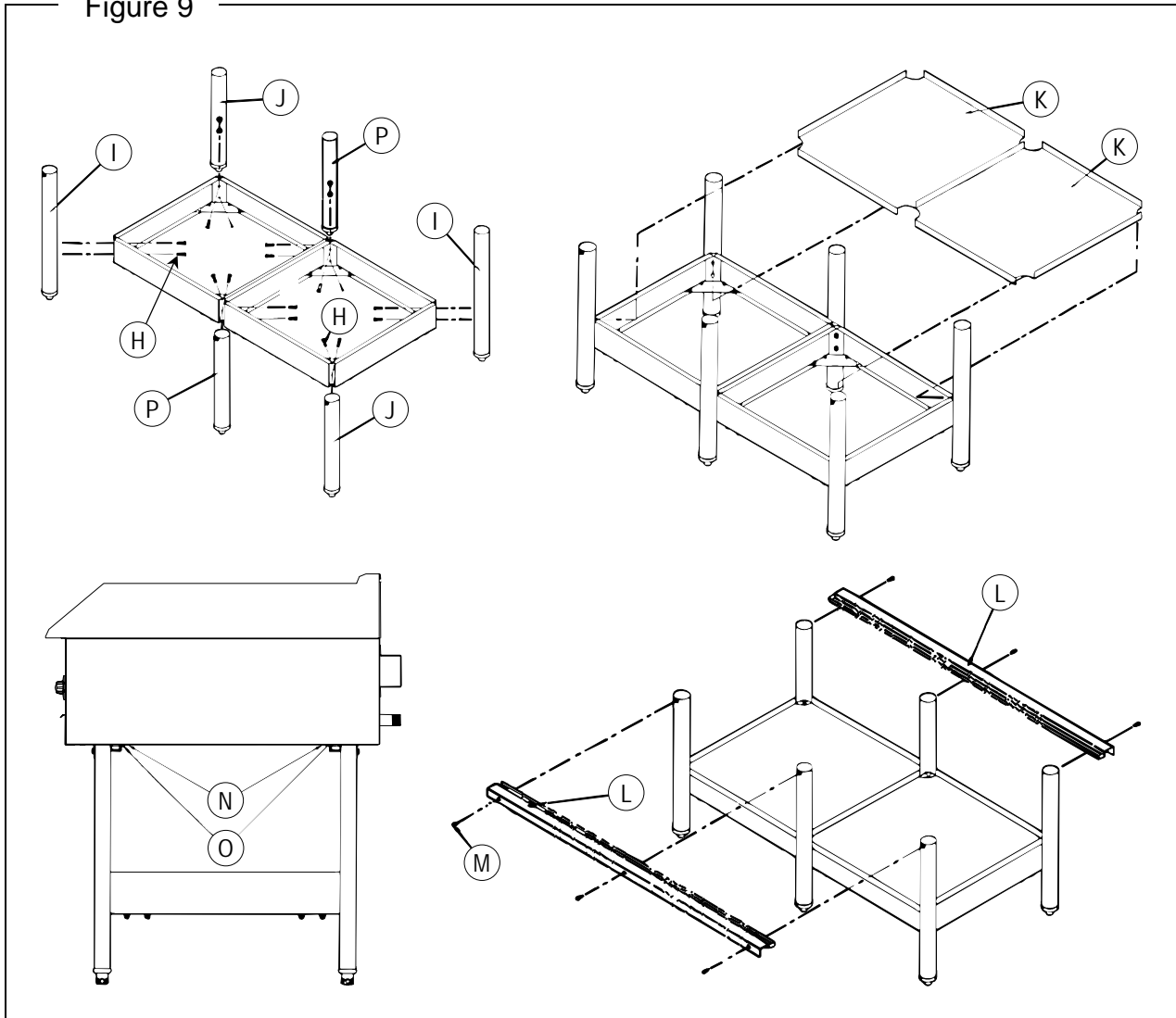


6. Use the twelve 1-1/2" hex bolts (items "H" in Figure 9) to attach the two left-legs (items "I"), the two right-legs (items "J"), and the two center-legs (items "P"). "Left" and "right" are as seen from the front or rear of the stand. Be sure that the small threaded-insert near the top of each leg faces either the front or the rear of the stand, not a side. Insert the bolts through the leg brackets and into the legs. Only hand-tighten the bolts for now.



Figure 9

INSTALLATION



7. Check the partially assembled stand to make sure that the legs are straight and that all corners are square. Now tighten all bolts, but do not over tighten.
8. If legs with casters were ordered, lift the stand and screw the caster assemblies into the bottom of the legs. The two casters with wheel-locks go on the front corner legs. **After the stand is assembled, connect the required restraint to protect the flexible gas connection (see Step 3 on page 15).**
9. If the optional shelves were ordered (items "K"), position them on top of the bottom braces. The down-flange edge of each shelf should be on the front side of the stand. The shelves simply rest on the bottom braces (they are not bolted or screwed to the braces).
10. Position the front and rear top supports (items "L") over the legs. The pre-drilled holes should face the outside of the stand to line up with the threaded-insert holes near the top of the legs. Use the six 5/8" hex-head bolts (items "M") to secure the top supports to the legs.
11. Attach the angle support brackets (item "N", shipped with the griddle) to the bottom of the of the griddle using #10x1/2" sheet metal screws (item "O", also shipped with the griddle).
12. Place the griddle on top of the stand, making sure that the angle brackets that you just installed on the bottom of the griddle are inserted into the front and rear top supports. No additional bolts or screws are required. **Lift the griddle only at the ends, never in the middle!**
13. Go on to Step 4 on page 16.



### Step 3: Attach Restraint for Griddles Mounted on Casters

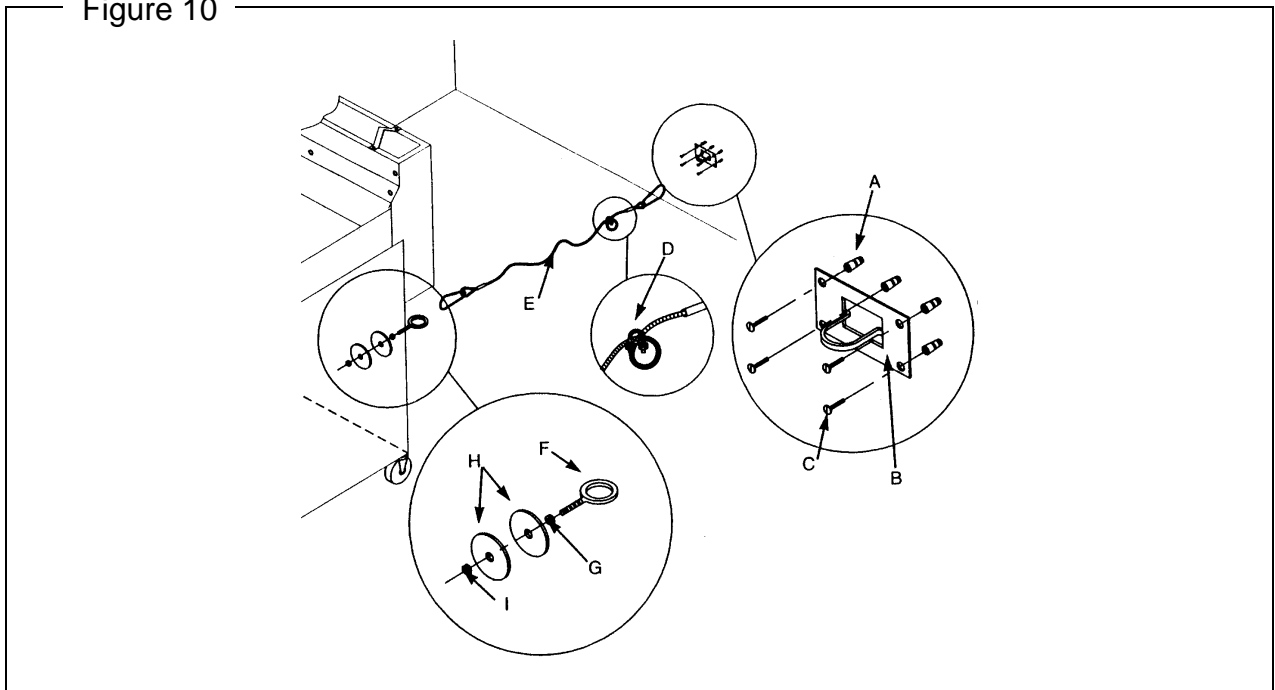
#### NOTICE

For an appliance equipped with casters, (1) the installation shall be made with a connector that complies with the *Standard for Connectors for Movable Gas Appliances, ANSI Z21.69* or *Connectors for Moveable Gas Appliances, CAN/CGA-6.16*, and a quick-disconnect device that complies with the *Standard for Quick-Disconnect Devices for Use With Gas Fuel, ANSI Z21.41*, or *Quick Disconnect Devices for Use with Gas Fuel, CAN1-6.9*, (2) adequate means must be provided to limit the movement of the appliance without depending on the connector and the quick-disconnect device or its associated piping to limit the appliance movement and (3) the restraining means should be attached to a frame member on the back of the griddle.

Griddles mounted on a stand with casters or other movable surface must be equipped with a restraining means to prevent accidental stress on the flexible gas connection.

1. Secure the restraining-device bracket (item "B" in the following illustration) to a wall stud located as close as possible to the appliance connector inlet and outlet connections. Use four #12 screws (items "C") and plastic anchors (items "A") if necessary.
2. Install eye-bolt (item "F") to a frame member on the rear of the counter griddle. After checking carefully behind the frame member for adequate clearance, drill a 1/4" hole through the frame member.
3. Thread hex nut (item "G") and slide the washer (item "H") onto the eye-bolt. Insert the eye-bolt through the 1/4" drilled hole and secure with a washer (item "H") and nylon lock nut (item "I").
4. Using the spring-loaded snap hooks, attach the restraining device to the bracket and the eye-bolt.
5. Using the cable clamp (item "D"), adjust the restraining device extended length to prevent over-bending or kinking of the appliance connector.

Figure 10



**Note:** For griddles not equipped with flame safety devices, be sure all valves are turned off prior to disconnecting. After reconnecting, be sure all valves are turned off and all pilots are lit.



## Step 4: Connect Gas Supply

The serial plate is located interior side of the control panel (see Figure 1 on page 3). It indicates the type of gas the griddle is equipped to burn. All Southbend equipment is adjusted at the factory. Check type of gas on serial plate. This appliance should be connected **ONLY** to the type of gas for which it is equipped.

If the griddle is being installed at over 2,000 feet altitude and that information was not specified when ordered, contact the appropriate authorized Southbend Service Representative or the Southbend Service Department. Failure to install with proper orifice sizing will result in poor performance and may void the warranty.

These models are design-certified for operation on natural or propane gases. For natural gas, the convertible regulator shipped with the griddle is set to deliver a 4" W.C. pressure to the manifold. For propane gas, it is set to deliver 10" W.C.

An adequate gas supply is imperative. Undersized or low pressure lines will restrict the volume of gas required for satisfactory performance. Fluctuations of more than 25% on natural gas or 10% on propane gas will create problems and affect burner operating characteristics. A 1/8" pressure tap is located on the manifold to measure pressure.

Purge the supply line to clean out dust, dirt, or other foreign matter before connecting the line to the griddle.

Use pipe joint compound that is suitable for use with LP gas on all threaded connections.

### CAUTION

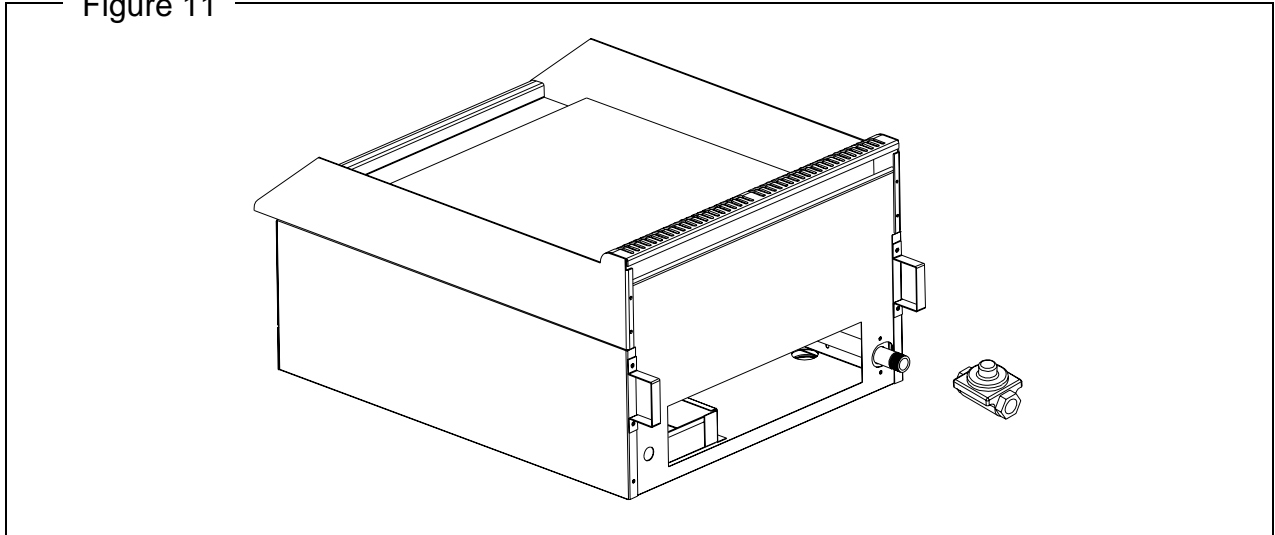
ALL PIPE JOINTS AND CONNECTIONS MUST BE TESTED THOROUGHLY FOR GAS LEAKS. USE ONLY SOAPY WATER FOR TESTING ON ALL GASES. NEVER USE AN OPEN FLAME TO CHECK FOR GAS LEAKS. ALL CONNECTIONS MUST BE CHECKED FOR LEAKS AFTER THE GRIDDLE HAS BEEN PUT INTO OPERATION. TEST PRESSURE SHOULD NOT EXCEED 14" W.C.

To connect the gas supply, do the following:

1. Check that the gas supply to the piping that will be connected to the griddle is shut off.
2. Check that the manual shut-off valve inside the front panel door of the griddle is closed (60" models have two shut-off valves).
3. Check that all control knobs on the griddle are turned "OFF."
4. Attach the pressure regulator shipped with the griddle to the 3/4" NPT gas inlet connector located on the rear of the griddle (see Figure 11 below). Be sure that the regulator is connected so that the gas flow is in the same direction as the arrow on the bottom of the regulator.
5. Connect the vent line from the pressure regulator to the outdoors in accordance with local codes or, in the absence of local codes, with the *National Fuel Gas Code, ANSI Z223.1, Natural Gas Installation Code, CAN/CGA-B149.1, or the Propane Installation Code, CAN/CGA-B149.2*, as applicable.
6. Connect the gas inlet of the pressure regulator to the building's supply system. No segment of the gas supply connection to the griddle should be smaller than 3/4" NPT. Standard pipe fittings are required.
7. Turn on gas supply.
8. Check for leaks using soapy water.



Figure 11



### Step 5: Final Positioning, Clearance Check, and Ventilation Check

1. Position the griddle where it will be operated.
2. Check that the griddle surface is level. The length of each leg is adjustable by screwing the bottom portion of the leg in or out. The griddle must be level for proper operation!
3. Check for adequate clearances around the griddle (see page 5).
4. Check for adequate ventilation (see page 5).

### Step 6: Check Pilot and Burner Operation

All griddles are adjusted at the factory. However, pilot heights, burner air shutters, and thermostatic valves should be checked at installation and adjusted if necessary. Do the following:

1. Turn main gas supply "ON".
2. Check the manifold gas pressure using the procedure on page 22.
3. Follow the procedure on page 20 to light the pilots.
4. Check (and, if necessary, adjust) the pilot flame heights using the procedure on page 23.
5. Follow the procedure on page 19 to light the burners. Set the control knobs to only low temperatures for now.
6. Check (and, if necessary, adjust) the burner air shutters using the procedure on page 23.

### Step 7: Condition Griddle Surface

New griddles should be carefully tempered and cared for in order to avoid possible damage. To break in a new griddle, do the following:

1. Wipe the griddle surface clean.
2. Light all the griddle burners and turn them to 200°F for one hour. Then gradually bring each griddle up to frying temperature.
3. Spread three or four ounces of beef suet, or as a substitute, baking soda, to season it. Never allow water on a hot griddle and never wash it with soap and water.



## Step 8: Check Griddle Temperature

Check (and, if necessary, adjust) the thermostatic valves that control the griddle's surface temperature. Follow the procedure on page 24.

INSTALLATION



# OPERATION

**⚠ DANGER  
EXPLOSION HAZARD**

Purchaser of equipment must post in a prominent location, detailed instructions to be followed in the event the operator smells gas. Obtain the instructions from the local gas supplier.

**⚠ CAUTION**

To eliminate gas build up which could result in an explosion, in the event of main burner ignition failure a five minute purge period must be observed prior to re-establishing ignition source.

**⚠ CAUTION**

Pilots, when out, do not interrupt the flow of gas to the burners. Consequently, it is the responsibility of the operator to check the ignition of the burners, immediately after burner valve has been turned "ON". Should ignition fail after 10 seconds, turn off burners, wait 5 minutes, and then try again.

**⚠ WARNING**

UNDER NO CIRCUMSTANCES IS THE GRIDDLE TO BE USED FOR HEATING STOCK POTS. SUCH USE AUTOMATICALLY VOIDS THE WARRANTY.

NEVER COOL THE GRIDDLE BY APPLYING ICE OR WATER TO THE GRIDDLE SURFACE. DAMAGE DUE TO MISUSE IS NOT COVERED BY THE WARRANTY.

DO NOT STRIKE THE GRIDDLE SURFACE WITH THE EDGE OF COOKING IMPLEMENTS TO CLEAN THE IMPLEMENTS. SUCH ACTION WILL CUT AND PIT THE GRIDDLE PLATE, LEAVING IT ROUGH AND HARD TO CLEAN.

ALWAYS HEAT THE GRIDDLE SLOWLY. DO NOT HEAT THE GRIDDLE ABOVE 550°F.

OPERATION

## GRIDDLE OPERATION

Each 12"-wide griddle section has a thermostatic-control knob on the front panel that directly controls the flow of gas, and so the heat. Turn the knob clockwise to increase the heat; turn it counterclockwise to reduce the heat.

The griddle will take approximately 13 minutes to heat to 350°F.

Do not waste gas or abuse equipment by leaving control knobs set at a high temperature if not required. During idle periods, set control knobs to low temperature settings to keep griddle warm.

After each period of use, allow the griddle surface to cool normally. At the end of each day's use, turn all control knobs to the "OFF" position. After the griddle has cooled, coat the griddle surface with a light film of cooking oil to protect the surface from moisture.



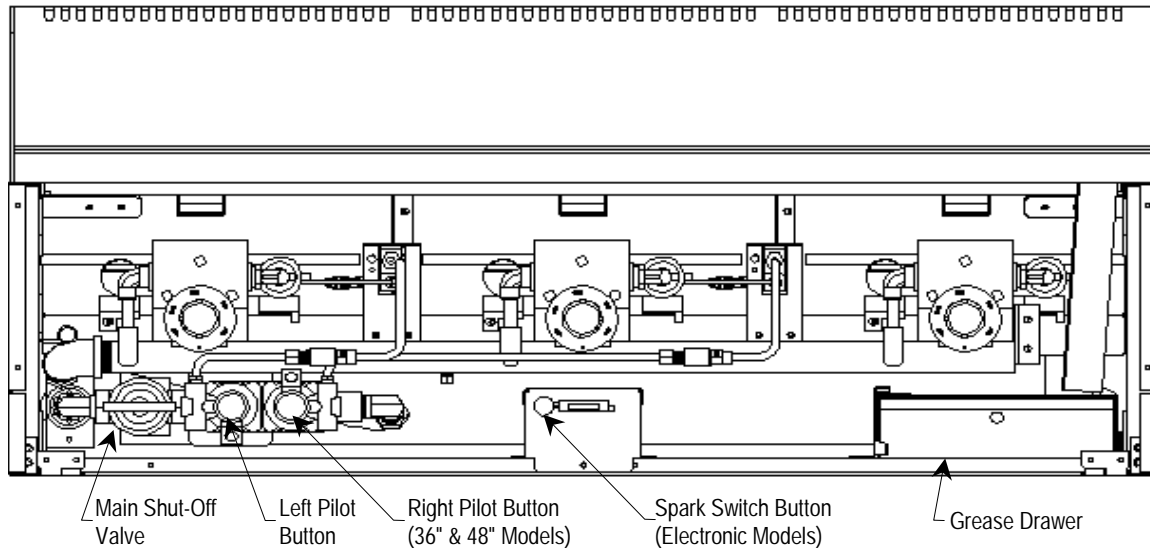
### LIGHTING THE PILOTS

If one or more of the burners does not ignite, check that the pilot(s) are lit. The controls for the pilots are located on the front of the griddle, behind the lower front panel door (see Figure 12 on page 20). To light the pilot(s), do the following:

1. Turn all griddle-thermostat controls to the "OFF" position.
2. Open the grease/control door at the bottom of the front of the griddle.
3. Turn the main shut-off valve to the "ON" position (if it is not already ON).
4. For each pilot, press and hold the red pilot button and light the pilot (either with a match, or, on models with electronic ignition, by pressing the electronic ignition button to generate a spark). Continue to hold the pilot button for 45 seconds, or until the pilot remains lit. Note that 24" models have one pilot, 36" & 48" models have two pilots, and 60" models have three pilots (one pilot and one shut-off valve in one burner compartment, and two pilots and one shut-off valve in a second burner compartment). Note that the left pilot must be lit before the right pilot can be lit.
5. If a pilot is extinguished or the gas supply is interrupted, wait five minutes and repeat the above steps.
6. Turn all griddle thermostat controls to the "ON" position to check that the pilots will ignite the burners.

Figure 12

This drawing shows a Model SGS-36 with the front panels removed so you can see the interior parts.



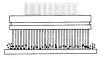
**Note:** 24" models have one pilot, 36" & 48" models have two pilots, and 60" models have three pilots (and two shut-off valves).

### OVERNIGHT SHUTDOWN

To shut down the griddle for overnight, turn all the burner control knobs to the "OFF" position to turn the burners off. The pilots will remain lit.

### EXTENDED-PERIOD SHUTDOWN

To shut down the griddle for an extended period (or before disconnecting the gas supply), turn all the burner control gas knobs "OFF," then turn the main gas supply valve(s) to "OFF" (see Figure 12 above).



# CLEANING

Southbend equipment is constructed with the best quality materials and is designed to provide durable service when properly maintained. To expect the best performance, your equipment must be maintained in good condition and cleaned daily. Naturally, the frequency and extent of cleaning depends on the amount and degree of usage.

**Daily:**

- A. Remove, empty, and clean grease drawers.
- B. Clean griddle drain chutes.

**Monthly:**

- A. Clean around burner air mixers and orifices if lint has accumulated.
- B. Visually assure proper pilot operation.

## CARE OF GRIDDLE SURFACE

Never allow water on a hot griddle and never wash it with soap and water.

Use a Norton Alundum Griddle Brick to clean the griddle. Always remember to heat griddle slowly because quick heat may cause costly damage. Griddle plates cannot be guaranteed against damage due to carelessness. Never place utensils on griddle. Do not overheat griddle above 550°F, as this will cause warpage or breakage.

Do not use any type of steel wool. Small particles may be left on the surface and get into food products. Do not clean spatula by hitting the edge on the griddle plate. Such action will only cut and pit the griddle plate, leaving it rough and hard to clean.

## CARE OF STAINLESS STEEL SURFACES

To remove normal dirt, grease and product residue from stainless steel that operates at LOW temperature, use ordinary soap and water (with or without detergent) applied with a sponge or cloth. Dry thoroughly with a clean cloth.

To remove grease and food splatter, or condensed vapors, that have BAKED on the equipment, apply cleanser to a damp cloth or sponge and rub cleanser on the metal in the direction of the polishing lines on the metal. Rubbing cleanser, as gently as possible, in the direction of the polished lines will not mar the finish of the stainless steel. NEVER RUB WITH A CIRCULAR MOTION. Soil and burnt deposits which do not respond to the above procedure can usually be removed by rubbing the surface with SCOTCH-BRITE scouring pads or STAINLESS scouring pads. DO NOT USE ORDINARY STEEL WOOL, as any particles left on the surface will rust and further spoil the appearance of the finish. NEVER USE A WIRE BRUSH, STEEL SCOURING PADS (EXCEPT STAINLESS), SCRAPER, FILE OR OTHER STEEL TOOLS. Surfaces which are marred collect dirt more rapidly and become more difficult to clean. Marring also increases the possibility of corrosive attack. Refinishing may then be required.

“Heat tint” is a darkened area that can appear on a stainless steel surface where the area has been subjected to excessive heat. These darkened areas are caused by thickening of the protective surface of the stainless steel and are not harmful. Heat tint can normally be removed by the foregoing, but tint which does not respond to this procedure calls for a vigorous scouring in the direction of the polish lines, using SCOTCH-BRITE scouring pads or a STAINLESS scouring pad in combination with a powered cleanser. Heat tint action may be lessened by not applying, or by reducing heat to equipment during slack periods.



# ADJUSTMENTS

## WARNING

ADJUSTMENTS AND SERVICE WORK MAY BE PERFORMED ONLY BY A QUALIFIED TECHNICIAN WHO IS EXPERIENCED IN, AND KNOWLEDGEABLE WITH, THE OPERATION OF COMMERCIAL COOKING EQUIPMENT. HOWEVER, TO ASSURE YOUR CONFIDENCE, CONTACT YOUR AUTHORIZED SERVICE AGENCY FOR RELIABLE SERVICE, DEPENDABLE ADVICE OR OTHER ASSISTANCE, AND FOR GENUINE FACTORY PARTS.

## NOTICE

The warranty will be void and the manufacturer relieved of all responsibility if...

- (A) Service work is performed by other than a qualified technician, or
- (B) Other than genuine Southbend replacement parts are installed.

ADJUSTMENTS

Before making any adjustment, make sure the griddle is connected to the type of gas for which it is equipped. That information is on the serial plate, which is located on the inside of the control panel (see Figure 1 on page 3).

## MANIFOLD GAS PRESSURE CHECK

The pressure regulator is connected to the griddle's gas connection, outside the rear left corner of the griddle. The pressure regulator is factory set at 4" W.C. for natural gas and 10" W.C. for propane. To check the manifold pressure, do the following:

1. Turn all burner valves to "OFF" position.
2. Turn main gas valve to entire griddle off.
3. Remove front panel and locate 1/8" plug in manifold. (Note that a 60" model has two burner compartments, and so has two manifolds.)
4. Remove plug and install a fitting appropriate to connect a manometer.
5. Turn on main gas to griddle and light pilots (the procedure is described on page 20).
6. Turn all burners to full "ON" position and read manometer.
7. If manometer does not read 4" W.C. for natural gas (or 10" W.C. for propane gas), check the incoming gas line for proper pressure.
8. Remove manometer fitting and replace plug in manifold.
9. Replace front panel.
10. Turn on main gas to griddle and light pilots.

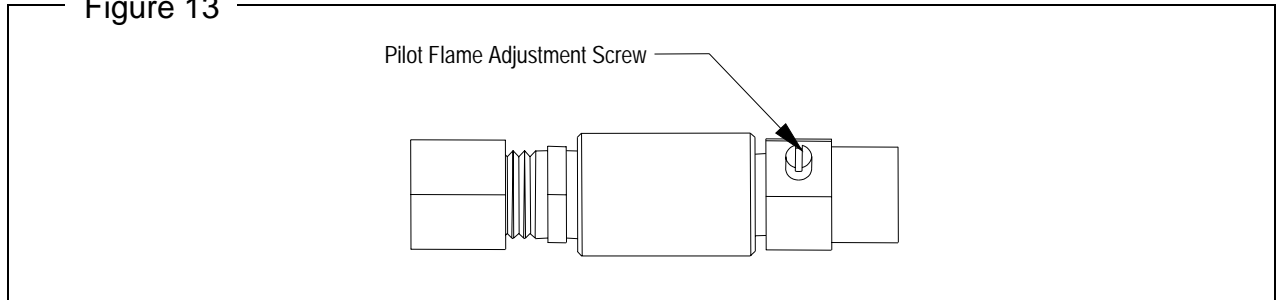


## PILOT FLAME ADJUSTMENT

The pilots are adjusted at the factory. If later the pilots are over-adjusted to the point where the flame is leaving its port, or "blowing off," the result is an unstable condition in which the pilot may extinguish. If necessary, adjust each burner's pilot using the following procedure:

1. Open the door on the lower front of the griddle, remove the thermostat knobs, and remove the control panel by removing the screws holding it in place.
2. If necessary, light the pilot (the procedure is described on page 20).
3. Locate the pilot adjustment valve (see Figure 13 below). Turn the pilot adjustment screw to the right to increase the size of the pilot flame, or to the left to decrease the size of the pilot flame. The flame should be about 1/2" high and cover the thermocouple tip.
4. Repeat Step 3 for each pilot (24" models have one pilot, 36" & 48" models have two pilots, and 60" models have three pilots).
5. Replace the control panel and knobs.

Figure 13



ADJUSTMENTS

## BURNER FLAME ADJUSTMENT

The burners are adjusted at the factory. If necessary to adjust the burner flames, do the following for each burner:

1. Turn the burner's control knob to the full ON position.
2. If the griddle was cold, wait 5 minutes before adjusting the burner flame.
3. Loosen the set screw that holds the sheet-metal air shutter in place.
4. If the burner flame is blowing or lifting off the burner ports, close the air shutter until a stable flame is obtained. If instead the flame is yellow-tipping, open the air shutter until a stable flame is obtained.
5. Tighten the set screw that holds the sheet-metal air shutter in place.
6. Repeat Steps 1 through 5 for each burner (24" models have two burners, 36" models have three burners, 48" models have four burners, and 60" models have five burners).

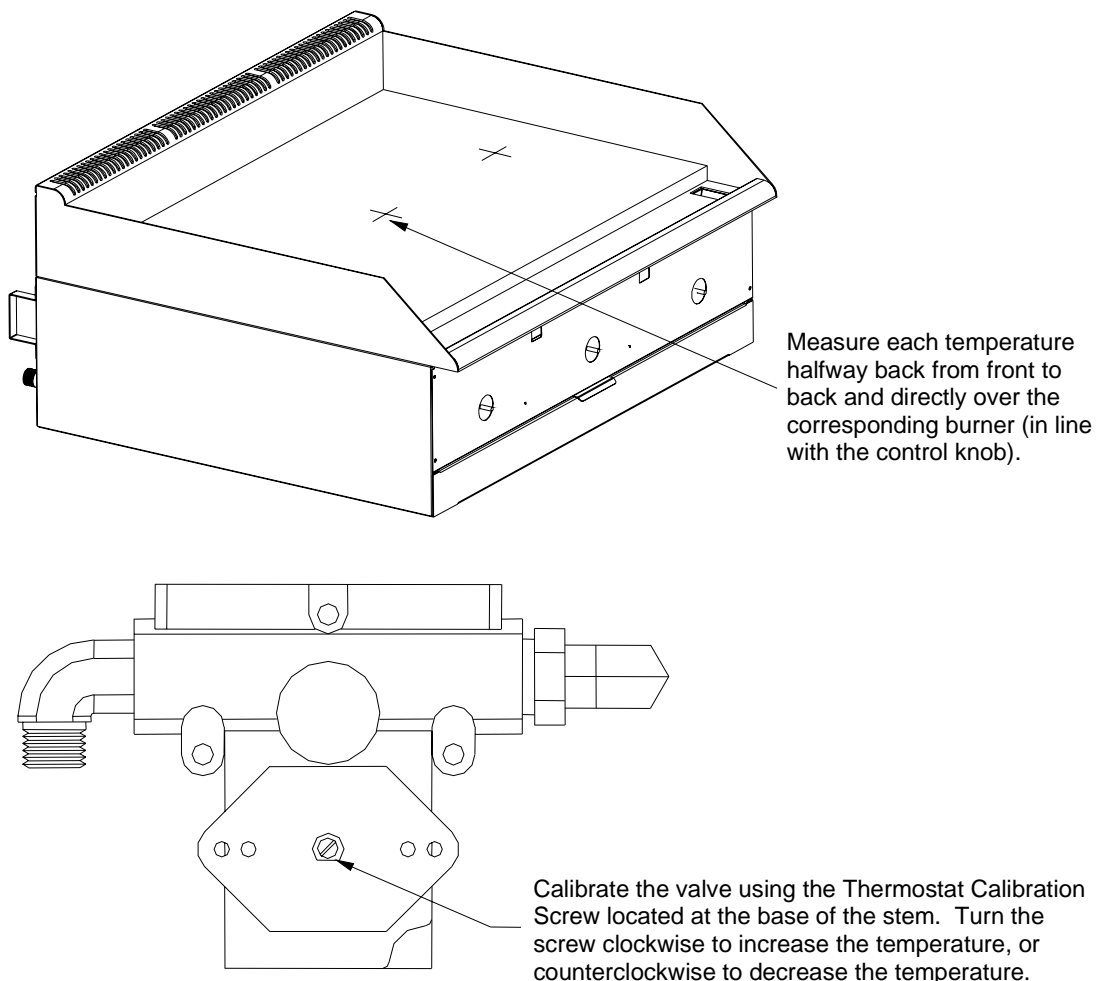


## THERMOSTAT ADJUSTMENT

Each burner's control knob operates a snap-action thermostatic valve that was adjusted at the factory. If the griddle surface temperature is different from the thermostat dial setting, adjust the valve using the following procedure:

1. Turn all the control knobs to the 300°F.
2. Wait 30 minutes (or 1 hour if the griddle was cold).
3. Place a reliable thermometer or test-instrument thermocouple (able to register 300°F) halfway back from the front to the back of the griddle and directly over a burner (in line with the burner's control knob, see Figure 14 below). Check the temperature over each burner every five minutes until the temperature over each burner stabilizes and does not change by more than 30°F between two consecutive measurements.
4. If the temperature over any burner is not within 30°F of the knob setting (300°F), adjust the corresponding thermostatic valve. To do so, remove the knobs and control panel, adjust the calibration screw on the thermostatic valve (see Figure 14 below), replace the knobs and control panel, then repeat Step 3.

Figure 14



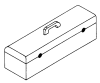
ADJUSTMENTS



## CONVERSION FROM ONE TYPE OF GAS TO ANOTHER

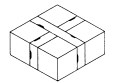
Each griddle is shipped equipped for use with either natural gas or LP gas (propane). To convert a griddle from one type of gas to another, do the following:

1. Remove the front panel by removing the knobs and screws on the front.
2. For each burner, replace the orifice with the type appropriate for the type of gas that will be used (see parts list on page 30). For special gas mixtures, and for altitudes above 2,000 feet, consult factory for appropriate orifice sizes.
3. For each pilot, replace the pilot assembly (item 20 in the parts list on page 30; 24" models have one pilot, 36" & 48" models have two pilots, and 60" models have three pilots).
4. Re-install the front panel.
5. Remove the hex-threaded plug from the pressure regulator (on the rear of the griddle). Inside is a removable insert. Pull the insert out, turn it around, and put it back in so that the end facing you has the letters corresponding to the type of gas that will be used ("NAT" or "LP"). Re-attach the hex-threaded plug.
6. Check the manifold pressure (the procedure is on page 22).



# TROUBLESHOOTING

<b>Problem</b>	<b>Look for -</b>
Griddle will not heat up	<ul style="list-style-type: none"><li>- Main gas supply to griddle is "OFF"</li><li>- Pilot(s) not lit</li><li>- Defective thermostat(s)</li><li>- Clogged orifice or burner ports</li></ul>
Burners produce excessive carbon deposits	<ul style="list-style-type: none"><li>- Incorrect gas type or orifice size</li><li>- Incorrect supply pressure</li><li>- Incorrect burner air mixer adjustment</li><li>- Burner orifice out of alignment with burner</li><li>- Incorrect orifices</li></ul>
Pilot produces excessive carbon deposits	<ul style="list-style-type: none"><li>- Pilot gas not adjusted properly</li><li>- Incorrect pilot orifice</li></ul>
Pilot will not stay lit	<ul style="list-style-type: none"><li>- Pilot not adjusted properly</li><li>- Clogged or dirty orifice</li><li>- Draft condition</li><li>- Improper ventilation system</li><li>- Air in gas line</li><li>- Valve end of thermocouple corroded or loose</li><li>- Pilot shield needs to be moved closer to pilot</li><li>- Improper gas pressure</li><li>- Incorrect gas supply size (not enough volume)</li><li>- Defective thermocouple</li></ul>
Electronic ignition module (on models so equipped) will not generate a spark	<ul style="list-style-type: none"><li>- Dead battery in ignition module</li><li>- Defective spark module</li></ul>



# PARTS

**NOTICE**

INSTALLATION OF OTHER THAN GENUINE SOUTHBEND PARTS WILL VOID THE WARRANTY ON THIS EQUIPMENT.

The serial plate is located inside of the control panel on the front of the griddle (see Figure 1 on page 3).

Replacement parts may be ordered either through a Southbend Authorized Parts Distributor or a Southbend Authorized Service Agency.

When ordering parts, please supply the Model Number, Serial Number, Part Number, and Description.

For parts not listed, consult a Southbend Authorized Parts Distributor or Southbend Authorized Service Agency. Consult the Southbend Authorized Parts/Service Distributor list for the Authorized Parts supplier in your area. If this list is not available, call Southbend at 1-800-348-2558 to obtain this list.

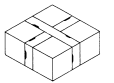
Except where the a part number is explicitly associated with a particular model number, all parts listed are used by all the models covered by this manual: SGS-24, SGS-24E, SGS-36, SGS-36E, SGS-48, SGS-48E, SGS-60, and SGS-60E. (An “E” suffix on a model number indicates that the model is equipped with electronic ignition for lighting the pilots.)

<b>Index of Parts Diagrams</b>	
Page Number	Description
28	Chassis Parts
30	Gas System Parts
32	Floor Stand Parts for 24", 36", and 48" Width Griddles
34	Floor Stand Parts for 60" Width Griddles
36	Countertop Legs and Insulated-Base Parts



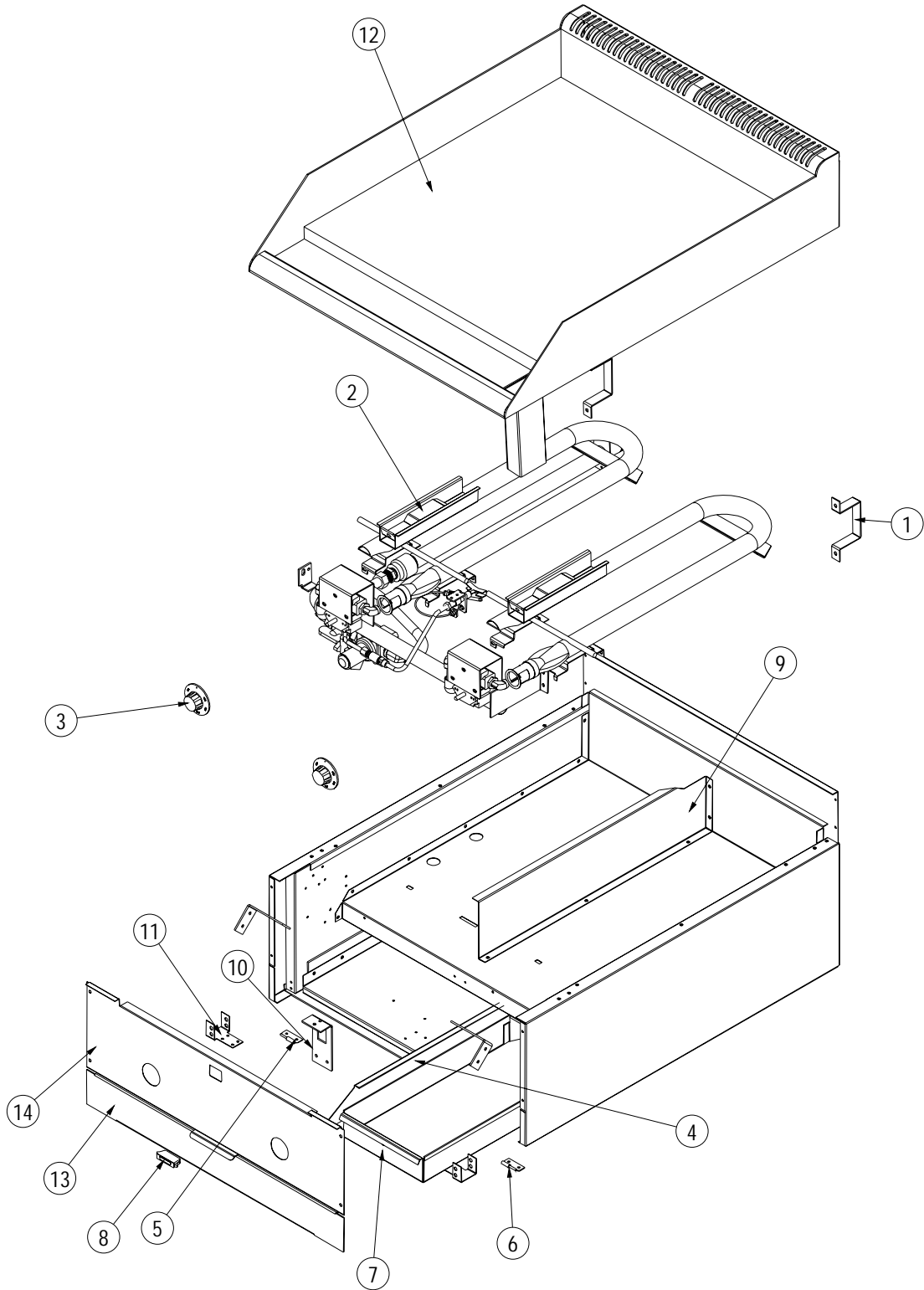
<b>Chassis Parts</b>						
See drawing on following page.						
Key	Part Number	Quantity for Griddle Width*				Description
		24"	36"	48"	60"	
1	<a href="#">1180299</a>	2	2	2	2	Bracket, standoff
2	<a href="#">1182583</a>	2	3	4	5	Bulb cover weld assembly
3	<a href="#">1182586</a>	2	3	4	5	Knob
4	<a href="#">1182588</a>	1	1	1	1	Drawer guide
5	<a href="#">1182591</a>	1	1	1	2	Hinge, male, right
6	<a href="#">1182592</a>	1	1	1	2	Hinge, male, left
7	<a href="#">1182604</a>	1	1	1	1	Grease drawer weld assembly
8	<a href="#">1182637</a>	1	1	1	2	Catch, magnetic
9	<a href="#">1182554</a>	1	2	3	3	Burner divider
10	<a href="#">1182557</a>	2	3	4	5	Pilot assembly bracket
11	1182558	2	2	2	4	Hinge bracket
12	<a href="#">1182611</a>	1	-	-	-	Smooth-griddle weld assembly, 24" **
	<a href="#">1182608</a>	-	1	-	-	Smooth-griddle weld assembly, 36" **
	<a href="#">1182609</a>	-	-	1	-	Smooth-griddle weld assembly, 48" **
	<a href="#">1182605</a>	-	-	-	1	Smooth-griddle weld assembly, 60" **
13	<a href="#">1182612</a>	1	-	-	1	Door weld assembly, 24"
	<a href="#">1182620</a>	-	1	-	1	Door weld assembly, 36"
	<a href="#">1182624</a>	-	-	1	-	Door weld assembly, 48"
14	<a href="#">1182618</a>	1	-	-	1	Control panel, 24"
	<a href="#">1182552</a>	-	1	-	1	Control panel, 36"
	<a href="#">1182627</a>	-	-	1	-	Control panel, 48"
***	<a href="#">1180145</a>	1	-	-	1	Polypanel, 24"
	1182631	-	1	-	1	Polypanel, 36"
	<a href="#">1182632</a>	-	-	1	-	Polypanel, 48"

\* Griddle width is 24" for models SGS-24/24E, 36" for models SGS-36/36E, 48" for models SGS-48/48E, and 60" for models SGS-60/60E.  
 \*\* Contact Southbend to obtain part numbers for optional grooved-griddle assemblies.  
 \*\*\* Not shown on drawing.



### Chassis Parts

See parts list on previous page. Model SGS-24 is shown.

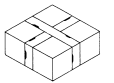


PARTS



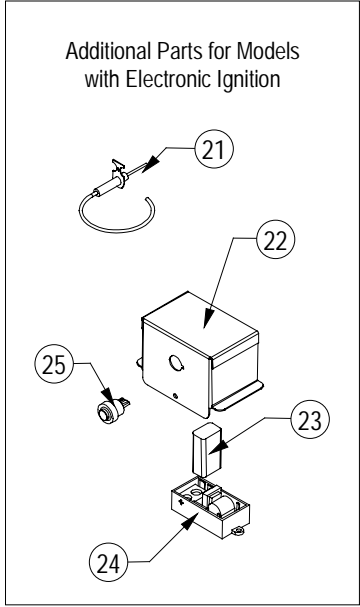
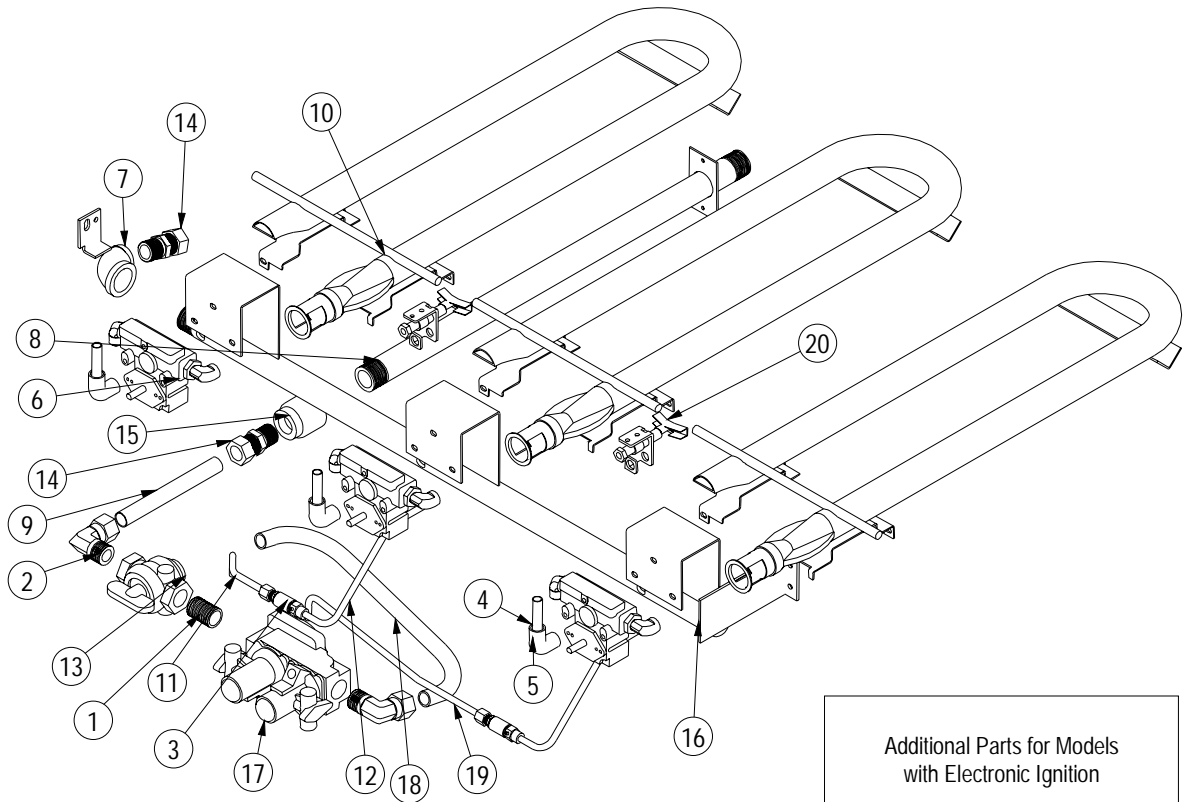
<b>Gas System Parts</b>						
See drawing on following page.						
Key	Part Number	Quantity for Griddle Width*				Description
		24"	36"	48"	60"	
1	<a href="#">1146806</a>	1	1	1	2	Nipple, pipe, close, black, 1/2"
2	<a href="#">1160008</a>	1	1	1	2	Elbow, brass
3	<a href="#">1164085</a>	1	2	2	3	Valve assembly, pilot
4	<a href="#">1166150</a>	2	3	4	5	Male elbow
5	<a href="#">1181499</a>	2	3	4	5	Tubing, 3/8 x 1.750
6	<a href="#">1182553</a>	2	3	4	5	Valve assembly, thermostat
7	<a href="#">1182562</a>	1	1	1	2	Elbow bracket weld assembly
8	<a href="#">1182564</a>	1	1	1	2	Supply pipe bracket weld assembly
9	1182566	1	1	1	2	Tube, 5/8" supply
10	1182610	2	3	4	5	Burner assembly
11	1182639	1	1	1	2	Pilot tube left
12	<a href="#">1182640</a>	1	2	2	3	Pilot tube extension
13	1-5771	1	1	1	2	Valve, shut off, 1/2"
14	<a href="#">P9158</a>	2	2	2	4	Connector, brass, 68C-10-8
15	<a href="#">P5244-4</a>	1	1	1	2	Pipe reducer
16	<a href="#">1182574</a>	1	-	-	1	24" manifold weld assembly
	<a href="#">1182560</a>	-	1	-	1	36" manifold weld assembly
	<a href="#">1182571</a>	-	-	1	-	48" manifold weld assembly
17	<a href="#">1182594</a>	1	-	-	1	Safety valve, single
	<a href="#">1182567</a>	-	1	1	1	Safety valve, dual
18	<a href="#">1182633</a>	1	-	-	1	Tube, loop to safety, single
	<a href="#">1182638</a>	-	1	1	1	Tube, loop to safety, dual
19	<a href="#">1182641</a>	-	1	-	1	Tube, pilot 36" right
	<a href="#">1182642</a>	-	-	1	-	Tube, pilot 48" right
20	<a href="#">1182628</a>	1	2	2	3	Pilot assembly (NAT gas)
	<a href="#">1182635</a>	1	2	2	3	Pilot assembly (LP gas)
21	<a href="#">1182709</a>	1	2	2	3	Electrode **
22	<a href="#">1182707</a>	1	1	1	1	Cover, electronic ignition **
23	1182705	1	1	1	1	Battery, 9V **
24	<a href="#">1182706</a>	1	1	1	1	Module, spark **
25	<a href="#">1182704</a>	1	1	1	1	Switch, ignition **
***	<a href="#">1057200</a>	2	3	4	5	Orifice fitting
***	<a href="#">1008732</a>	2	3	4	5	Orifice NAT gas
***	<a href="#">1008752</a>	2	3	4	5	Orifice LP gas
***	<a href="#">1178815</a>	1	1	1	1	Pressure regulator, LP/NAT
***	<a href="#">1182648</a>	-	-	-	1	Tube, rear, gas supply, 60" only

\* Griddle width is 24" for models SGS-24/24E, 36" for models SGS-36/36E, 48" for models SGS-48/48E, and 60" for models SGS-60/60E.  
\*\* Only for models with electronic ignition (models SGS-24E, SGS-36E, SGS-48E, and SGS60E)  
\*\*\* Not shown on drawing.



### Gas System Parts

See parts list on previous page. Model SGS-36 is shown.



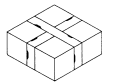
**Floor Stand Parts for 24", 36", and 48" Width Griddles**

See drawing on following page.

Key	Part Number for Griddle Width*			Qty	Description
	24"	36"	48"		
1	1173709	1173709	1173709	2	Bottom brace, left & right sides
2	1173710	1173723	1173724	2	Bottom brace, front & rear
3	1173707	1173707	1173707	4	Leg bracket
4	1173706	1173706	1173706	4	Corner brace
5	1146500	1146500	1146500	16	1/4" lock washer
6	1146200	1146200	1146200	16	1/4" - 20 x 1/2 hex head bolt
7	1164827	1164827	1164827	16	1/4 - 20 acorn nut
8	1146203	1146203	1146203	8	1/4 - 20 x 1-1/4 hex head bolt
9	1173721	1173720	1173722	2	Front & rear top support
10	1146518	1146518	1146518	4	1/4 - 20 x 5/8 hex head bolt
11	1173590	1173590	1173590	2	Left leg assembly
	1173592	1173592	1173592	2	Left leg assembly for use with casters
12	1173589	1173589	1173589	2	Right leg assembly
	1173591	1173591	1173591	2	Right leg assembly for use with casters
13	1173717	1173718	1173719	1	Shelf (optional)
14	1173725	1173726	1173727	2	Mount angle
15	1146304	1146304	1146304	4	#10 x 1/2 sheet metal screw
**	1174264	1174264	1174264	2	Caster with lock (for front legs)
**	1174263	1174263	1174263	2	Caster without lock (for rear legs)
**	1174265	1174265	1174265	1	Caster package (two casters with lock, two casters without lock)

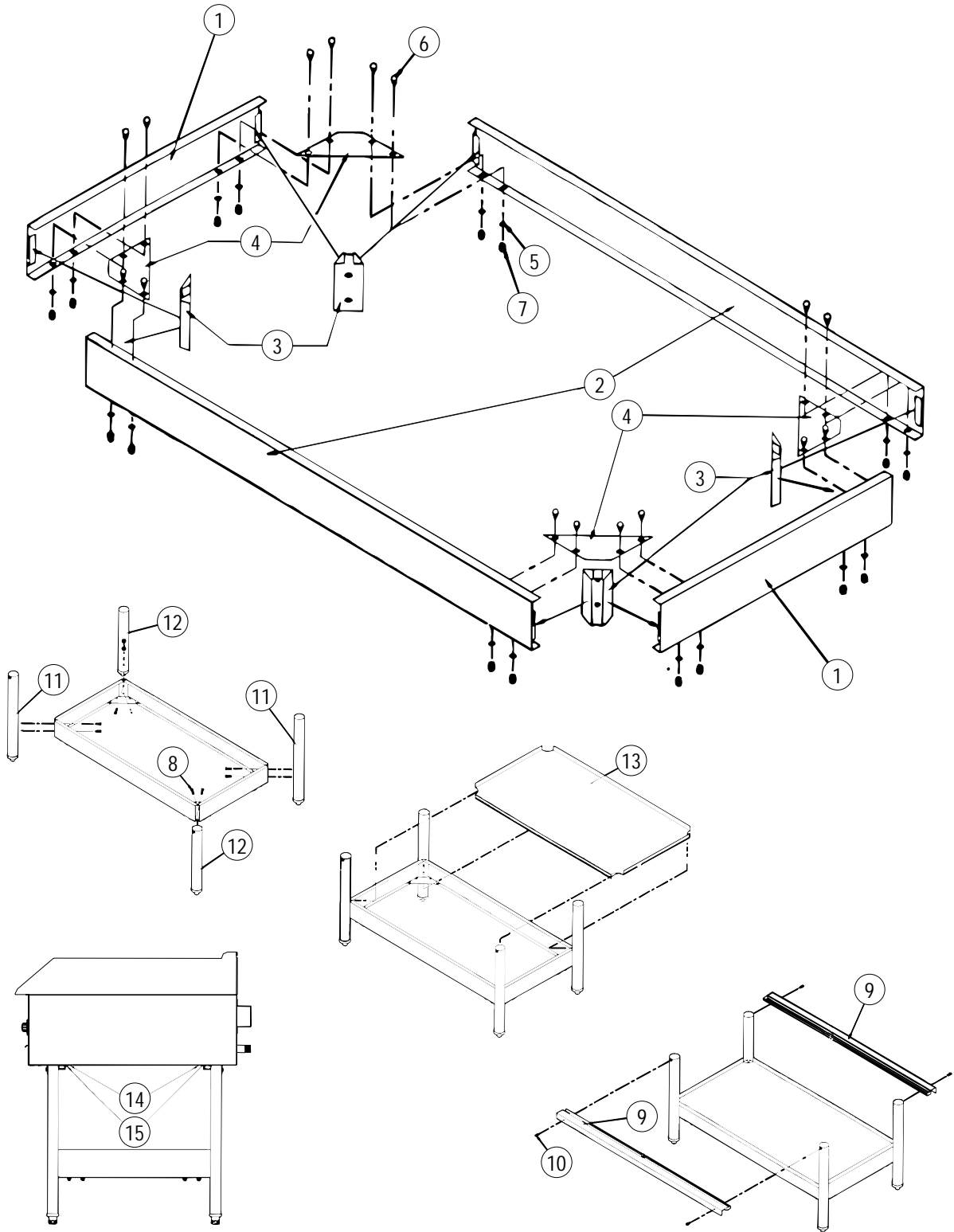
\* Griddle width is 24" for models SGS-24/24E, 36" for models SGS-36/36E, and 48" for models SGS-48/48E.

\*\* Not shown on drawing.



### Floor Stand Parts for 24", 36", and 48" Width Griddles

See parts list on previous page. Model SGS-36 is shown.



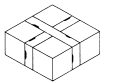
PARTS

**Floor Stand Parts for 60" Width Griddles**

See drawing on following page.

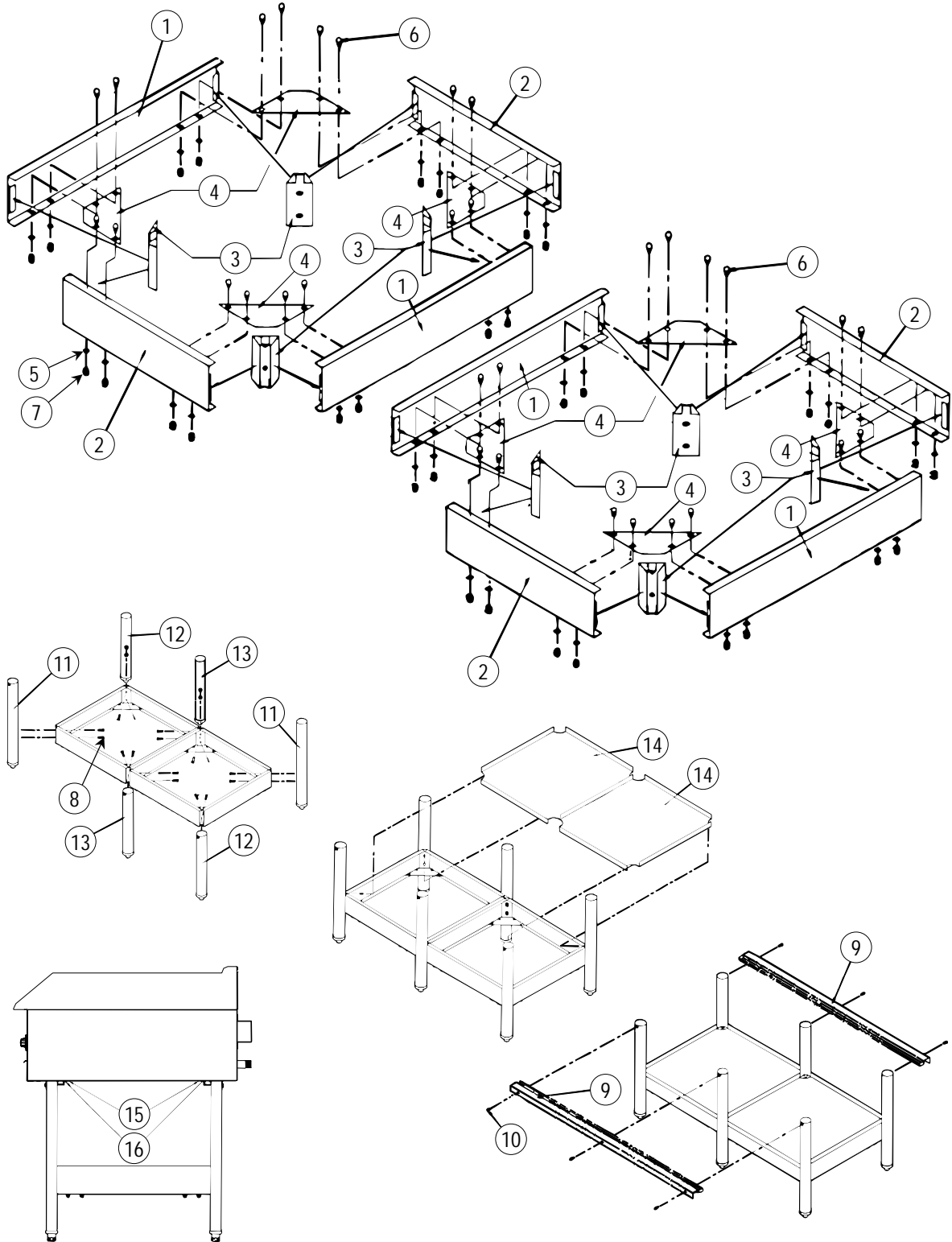
Key	Part Number	Qty	Description
1	<a href="#">1173709</a>	4	Bottom brace, left & right sides
2	<a href="#">1173728</a>	4	Bottom brace, front & rear
3	<a href="#">1173707</a>	8	Leg bracket
4	<a href="#">1173706</a>	8	Corner brace
5	<a href="#">1146500</a>	32	1/4" lock washer
6	<a href="#">1146200</a>	32	1/4" - 20 x 1/2 hex head bolt
7	<a href="#">1164827</a>	32	1/4 - 20 acorn nut
8	<a href="#">1146203</a>	16	1/4 - 20 x 1-1/4 hex head bolt
9	<a href="#">1173879</a>	2	Front & rear top support
10	<a href="#">1146518</a>	6	1/4 - 20 x 5/8 hex head bolt
11	<a href="#">1173590</a>	2	Left leg assembly
	<a href="#">1173592</a>	2	Left leg assembly for use with casters
12	<a href="#">1173589</a>	2	Right leg assembly
	<a href="#">1173591</a>	2	Right leg assembly for use with casters
13	<a href="#">1173731</a>	2	Center leg assembly
	<a href="#">1173732</a>	2	Center leg assembly for use with casters
14	<a href="#">1173881</a>	2	Shelf (optional)
15	<a href="#">1173733</a>	2	Mount angle
16	<a href="#">1146304</a>	6	#10 x 1/2 sheet metal screw
*	<a href="#">1174264</a>	2	Caster with lock (for front corner legs)
*	<a href="#">1174263</a>	4	Caster without lock (for front-center and rear legs)
*	<a href="#">1173708</a>	1	Caster package (two casters with lock, four casters without lock)

\* Not shown on drawing.

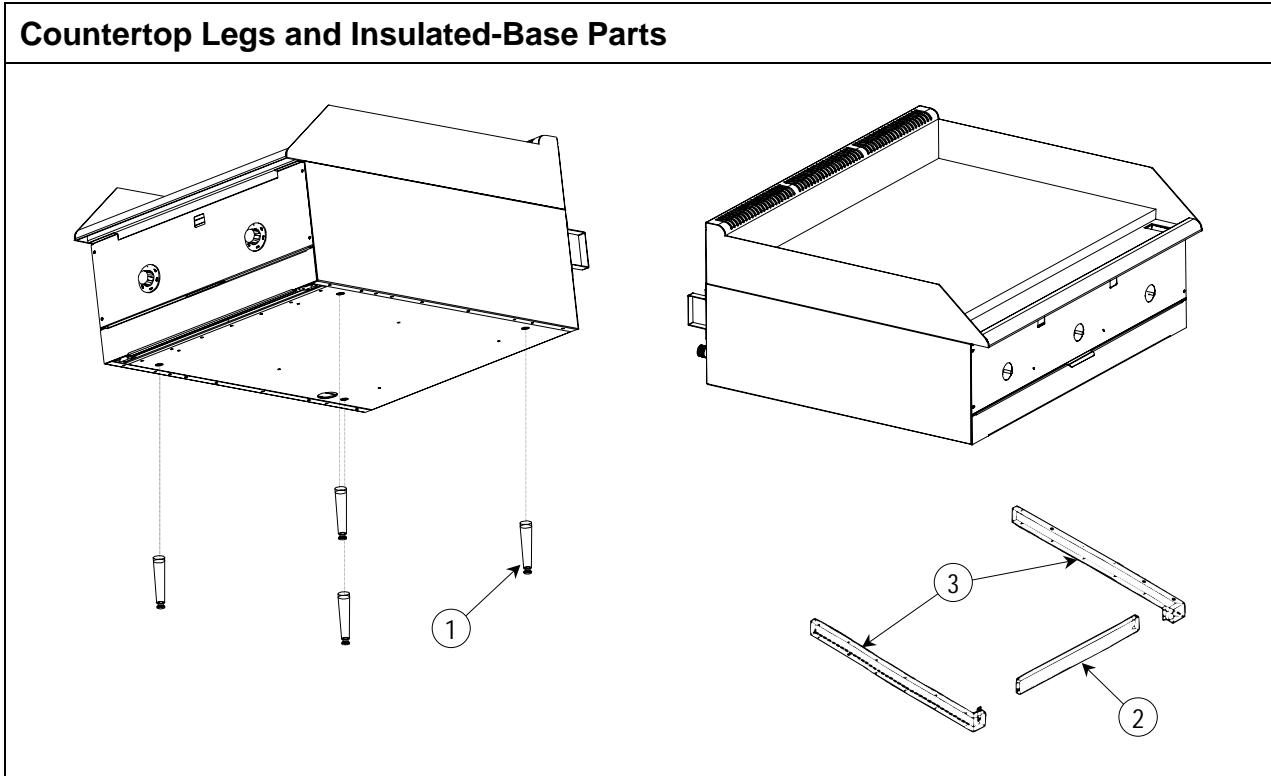
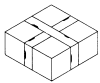


### Floor Stand Parts for 60" Width Griddles

See parts list on previous page. Model SGS-60 is shown.



PARTS



Key	Part Number for Griddle Width*				Qty	Description
	24"	36"	48"	60"		
1	1163561	1163561	1163561	1163561	4	4" leg (single)
	1172857	1172857	1172857	1172857	1	4" leg (set of 4)
2	1173884	1173885	1173886	1173887	1	Insulator front piece
3	1173883	1173883	1173883	1173883	2	Insulator side piece
**	1146304	1146304	1146304	1146304	4	Screw #10 x 1/2 truss head
**	1173888	1173889	1173890	1173891	1	Insulator base assembly (1 front, 2 sides, and 4 screws)

\* Griddle width is 24" for models SGS-24/24E, 36" for models SGS-36/36E, 48" for models SGS-48/48E, and 60" for models SGS-60/60E.  
 \*\* Not shown on drawing.

COUNTER GRIDDLE

# COUNTER GRIDDLE

A product with the Southbend name incorporates the best in durability and low maintenance. We all recognize, however, that replacement parts and occasional professional service may be necessary to extend the useful life of this unit. When service is needed, contact a Southbend Authorized Service Agency, or your dealer. To avoid confusion, always refer to the model number, serial number, and type of your unit.



Southbend  
1100 Old Honeycutt Road, Fuquay-Varina, NC 27526  
(800) 348-2558 or (919) 552-9161 • FAX (800) 348-2558 or (919) 552-9798