



# S E R V E R

SERVE BETTER™

## Twin Food Server

MODEL:  
TWIN FS-4

	COMPLETE	BASE ONLY
120V USA	81200	80360
120V SOUP WARMER	87635	87636
120V CUSTOM	87566	87636
120V (4 QT INSETS)	81199	80360
120V CUSTOM	87652	87653
230V CONT. EUROPE	81240	80370
230V AUSTRALIA	81470	80380
230V UNITED KINGDOM	84870	84790

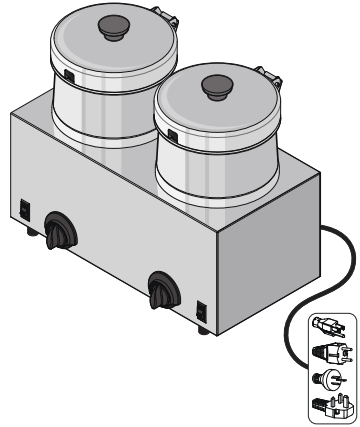

## Triple Food Server

MODEL:  
TRIPLE FS-4

	COMPLETE	BASE ONLY
120V USA	85900	85910
120V SOUP WARMER	87646	87647
120V CUSTOM	87622	87623

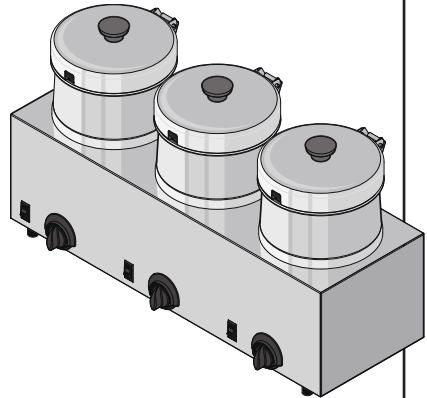

## Thank You

...for purchasing our Food Warmer to keep your chili, gravy, pulled meats, sauce and soup at the perfect temperature from the first serving to the last.

QUICKLY HEAT TO SAFE SERVING TEMPERATURE

# SAFETY



## WARNING- ELECTRICAL SHOCK COULD OCCUR

This unit must be earthed or grounded.

This requires all three prongs (terminals) on cord plug to be plugged into power source.



According to food and safety regulations, most foods must be stored and/or served at certain temperatures or they could become hazardous. Check with local food and safety regulators for specific guidelines.

**Be aware of the product you are serving and the temperature the product is required to maintain. Server Products, Inc. can not be responsible for the serving of potentially hazardous product.**

# PARTS

## PARTS MAY VARY DEPENDING ON UNIT

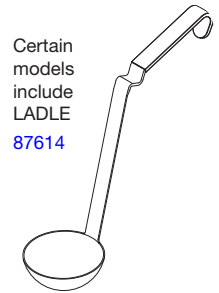
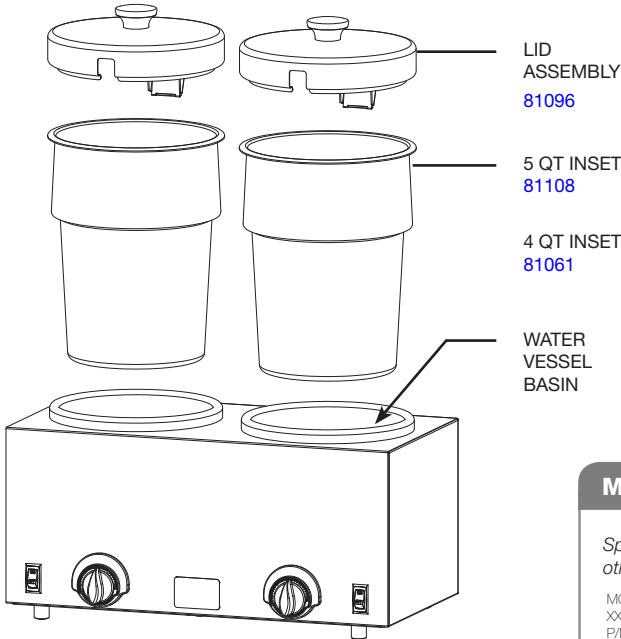

Certain models include LADLE 87614

BASE  
(see cover for part number)

## MODEL NUMBER

Specific model, P/N (part number) and other identification are labeled on base:

MODEL  
XXXX  
P/N  
#####



SERIES  
##X ##X

For additional details about your unit, visit [www.Server-Products.com](http://www.Server-Products.com)

Enter your P/N into the search bar.



# UNIT SET-UP

**WASH ALL PARTS PROPERLY BEFORE EVERY USE.** See page 6.

## 1 FILL WATER VESSEL BASINS

- Fill 2.5 cups (20 oz) of water up to water level line inside each basin.
- Do not overfill.



2.5 Cups Water = 0.59 Liter

**TIP:** Check water levels throughout the holding period to ensure even heating. Filtered water is recommended to deter corrosion.

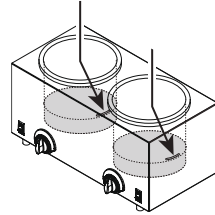

## 2 PUT INSETS INTO WATER VESSEL BASINS

- Product being served must always be inside insets.

**Never place food directly into water vessel basins of unit.**

**TIP:** Simplify change-outs with an additional inset and lid.

Order item #81111 for 5 Qt Inset & Lid or item #81050 for 4 Qt Inset & Lid

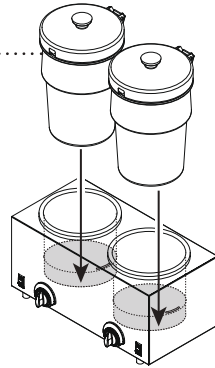

## 3 PLUG CORD into power source.

## 4 PRESS SWITCHES to the "ON" position.

## 5 SET THERMOSTAT KNOBS

to food manufacturer's recommended serving temperature(s).

- Pull knobs out to turn and adjust.
- Push knobs in to lock.
- Dial indicators use increments of 5° F.
- Thermostat ranges are 75°—210° F. (24°—99° C)
- To heat unit faster, thermostats may TEMPORARILY be rotated to maximum.

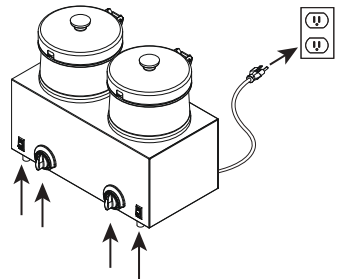

## REETHERMALIZATION

**Rethermalization** of food products is achieved by this appliance when it elevates the food product temperature from a refrigerated 40°F (4°C) to a safe serving temperature of 165°F (74°C) within a period of 2 hours.

### 1 PRE-HEAT UNIT

for at least 5 minutes with:

- Correct amount of water in basin.
- Lid closed.
- Thermostat knob set at maximum setting.

### 2 ADD FOOD PRODUCT

- Put food container into the water vessel basin.
- Maximum capacity of food product is 3 quarts (96 oz./12 cups). Do not overflow.

### 3 MAINTAIN SAFE HOT FOOD HOLDING

- After food reaches safe serving temperature of 165°F (74°C), maintain product temperature at or above 150°F (66°C).
- Adjust controller if needed to avoid overheating food.

## HOT FOOD HOLDING

**Hot Food Holding** is achieved with this appliance when it maintains a food product temperature at or above 150°F (66°C), in all locations throughout the product, for a minimum of 2 hours, even if any lid, cover, or pump is removed. The lid, cover, or pump is recommended to help maintain product temperature.

### 1 PRE-HEAT UNIT

for at least 5 minutes with:

- Correct amount of water in basin.
- Lid closed.
- Thermostat knob set at maximum setting.

### 2 ADD FOOD PRODUCT

- Put food which has already been preheated to 150°F (66°C) into container in water vessel basin.
- Maximum capacity of food product is 3 quarts (96 oz./12 cups). Do not overflow.

### MONITOR FOOD CLOSELY FOR FOOD SAFETY.

The United States Public Health Service recommends that hot food be held at a minimum of 140°F (60°C) to help prevent bacteria growth.

### COLD FOOD IS NOT TO BE ADDED TO THE UNIT FOR RETHERMALIZATION WHILE HOT FOOD IS BEING HELD.



NSF International and ANSI (American National Standards Institute) list this unit as a "Rethermalization and Hot Food Holding unit (Standard 4)."

## CARE OF STAINLESS STEEL

This warmer and accessories are constructed of stainless steel— one of the best materials for food serving and storage.

If you notice corrosion beginning on any stainless steel surface, you may need to change the cleansing agent, sanitizing agent, or the cleaning procedures you are using.

- A mildly abrasive nylon or brass brush may be used to remove any stubborn food or mineral deposits on interior surfaces of unit.
- Fully rinsing and drying all parts can help prevent corrosion. Elements and minerals in tap water can accumulate on stainless steel parts and create corrosion.
- Do not use abrasive, caustic or ammonia based cleansers.
- Do not use products containing acids, alkalines, chlorine, or salt. These agents can corrode stainless steel.
- Do not use metal scrapers or cleaning pads that could scratch surfaces.

# UNIT TAKE-DOWN

**1 PRESS SWITCHES** to the “OFF” position.

**2 UNPLUG CORD**



**CAUTION- HOT**  
Allow unit to cool before continuing.

**3 REMOVE INSETS FROM WATER VESSEL BASINS**

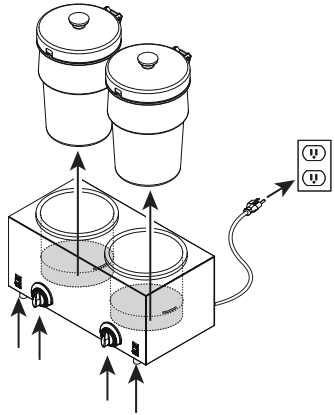

**4 EMPTY WATER FROM WATER VESSEL BASINS**  
after each use.

**TIP:** Remember to **empty** the water each day rather than **add**—

**This will greatly extend the life of your warmer.**

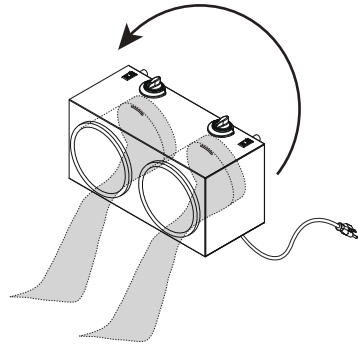

**5 DRY**  
thoroughly with a soft dry cloth.

*Proper drying after each use helps maintain the stainless steel.*

# CLEANING

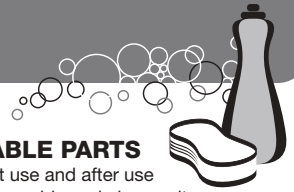

## WARNING- ELECTRICAL SHOCK COULD OCCUR

- Electrical components of unit could be damaged from water exposure or any liquid.
- Never immerse unit into water or any liquid.
- Never use any water jet or pressure sprayer on unit.
- Ensure unit is "OFF" and unplugged.

## CAUTION- HOT

Allow unit to cool before cleaning.



- 1 WASH REMOVABLE PARTS**
  - Before first use and after use daily, disassemble and clean unit.
  - Ensure unit is "OFF" and unplugged.
  - Wash with dishwashing soap and hot water.
- 2 RINSE** fully with clear water.
- 3 SANITIZE** all parts according to local sanitization requirements. All parts in contact with food must be sanitized.
- 4 DRY** all parts fully with a clean soft cloth.
- 5 CLEAN EXTERNAL SURFACES**
  - Wipe daily with a clean damp cloth.
  - Dry with a clean soft cloth.
  - Glass and surface cleaners approved for use in food contact areas may be used.

# WIRING SERIES 13C | TRIPLE FS-4

UNITS **85910**, **87647**, **87623** | 120V | USA

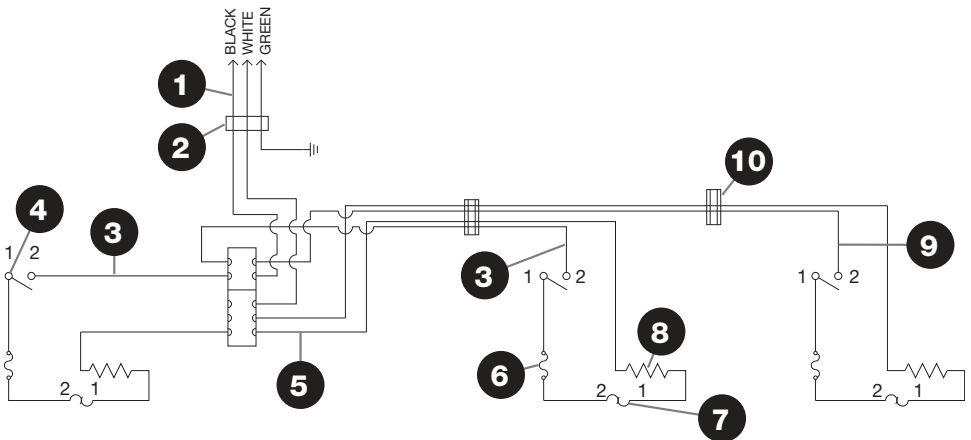

- |                                |                               |
|--------------------------------|-------------------------------|
| <b>1</b> Cord Assembly         | <b>6</b> Thermal Cutout       |
| <b>2</b> Bushing/Strain Relief | <b>7</b> Thermostat           |
| <b>3</b> Wire Asm, Black, 8"   | <b>8</b> 500W Heating Element |
| <b>4</b> Rocker Switch         | <b>9</b> Wire Asm, Black, 15" |
| <b>5</b> Terminal Block        | <b>10</b> Bushing, 9/16 Hole  |

# WIRING SERIES 13C | TWIN FS-4

**UNITS 80360, 87636, 87653**  
**120V | USA**

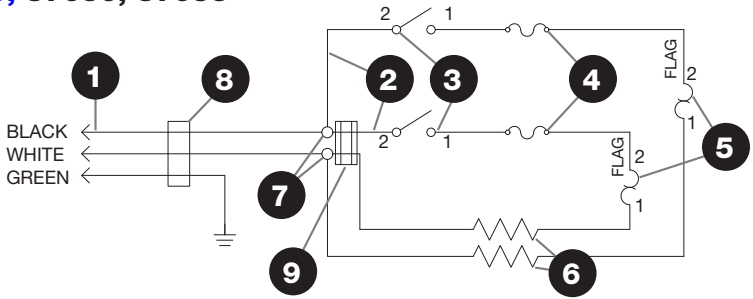

- 1** Cord Assembly
- 2** Wire Assembly
- 3** Rocker Switch
- 4** Thermal Cutout
- 5** Thermostat
- 6** 500W Heating Element
- 7** Wire Nut
- 8** Bushing/Strain Relief
- 9** Bushing, 5/16 Hole

**UNITS 80370, 80380, 84790 | 230V | CONT. EUROPE, AU, UK**

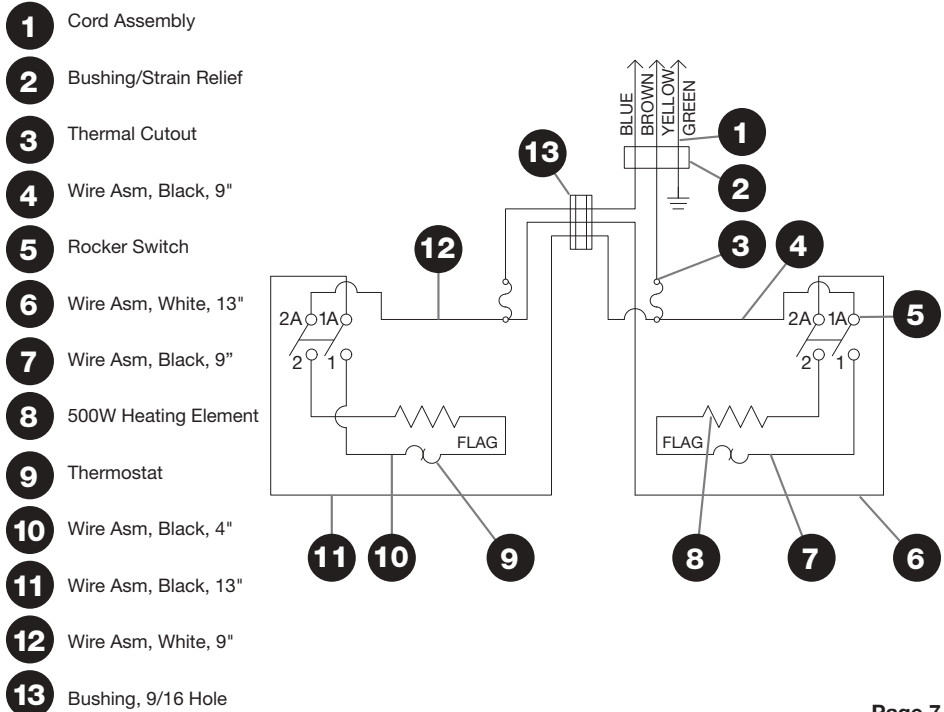

- 1** Cord Assembly
- 2** Bushing/Strain Relief
- 3** Thermal Cutout
- 4** Wire Asm, Black, 9"
- 5** Rocker Switch
- 6** Wire Asm, White, 13"
- 7** Wire Asm, Black, 9"
- 8** 500W Heating Element
- 9** Thermostat
- 10** Wire Asm, Black, 4"
- 11** Wire Asm, Black, 13"
- 12** Wire Asm, White, 9"
- 13** Bushing, 9/16 Hole

# TROUBLESHOOTING

## UNIT DOES NOT HEAT?

- Ensure cord is securely plugged in.
- Ensure power is available from source.
- Ensure unit is on.
- Ensure thermostat knob is set correctly.
- Ensure that the correct amount of water is in basin.
- Do not allow any of the electrical components to get wet. Moisture may cause the unit to trip breaker or GCFI. If moisture is suspected, discontinue use. Allow unit to fully air dry.

## PREVENT PITTING ON INSIDE SURFACE OF VESSEL

- Empty water from water vessel basin each day.
- Thoroughly dry basin each day.
- If possible, use filtered water to fill vessel basin.

## SERVER PRODUCTS LIMITED WARRANTY

**2**  
YEAR  
WARRANTY



Server Products equipment is backed by a two-year limited warranty against defects in materials and workmanship.

For complete warranty information go to:

[www.Server-Products.com](http://www.Server-Products.com)

## GENERAL SERVICE, REPAIR OR RETURNS

Before sending any item to Server Products for service, repair, or return, contact Server Products customer service to request a **Return Authorization Number**. Merchandise must be sent to Server Products with this number. Service is extremely prompt. Typically, units are repaired and ship out within 48 hours of receipt.

Merchandise being returned for credit must be in new and unused condition and not more than 90 days old and will be subject to a 20% restocking charge. Electrical parts (thermostats, heating elements, etc.) are not returnable.

**Servicing Cord:** Specific tools are required for safe and proper power supply cord removal and installation. If cord must be replaced, only a representative of the OEM (original equipment manufacturer) or a qualified technician may replace cord. Cord must meet code designation H05 RN-F requirements.

## GRAPHIC TEMPLATES

Would you like to add branding or imagery onto your warmer?

Templates are available for download. Please visit:  
[server-products/Graphics-01803.pdf](http://server-products/Graphics-01803.pdf)

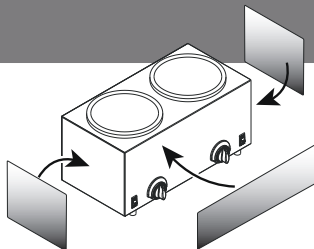

## NEED HELP?

### Server Products Inc.

3601 Pleasant Hill Road  
Richfield, WI 53076 USA



**262.628.5600 | 800.558.8722**



**SPSALES@SERVER-PRODUCTS.COM**

Please be prepared with your **Model, Part and Series Numbers**. This information and other important data is located on the base of the unit.