



S E R V E R

SERVE BETTER™



Maximo Sauce Dispensing Unit

MODEL: SPPG



**Chocolate
Maximo Unit**

88369



**Caramel
Maximo Unit**

88371



**White Chocolate
Maximo Unit**

88381

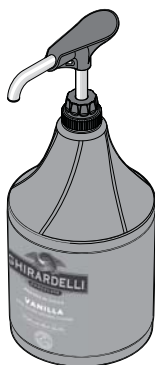

**Vanilla
Maximo Unit**

89235

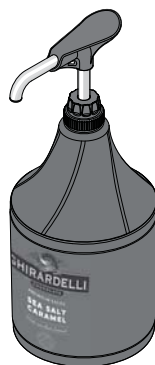

**Sea Salt Caramel
Maximo Unit**

89244

Thank You

...for purchasing your Maximo Sauce Dispensing Unit. This efficient, environmentally-friendly system delivers precise portions and is a reliable alternative to the constant expense of disposable pumps.

CONSISTENT PORTIONS—SERVE BETTER

*Ghirardelli Maximo
Sauce Dispensing
System Video Directions:*



SAFETY



According to food and safety regulations, most foods must be stored and/or served at certain temperatures or they could become hazardous. Check with local food and safety regulators for specific guidelines.

Be aware of the product you are serving and the temperature the product is required to maintain. Server Products, Inc. cannot be responsible for the serving of potentially hazardous product.

IMPORTANT

Clean, rinse, sanitize, and dry parts daily or regularly to comply with local sanitization requirements.



NSF International listed.

SEE SEPARATE PUMP MANUAL FOR IMPORTANT INSTRUCTIONS.

SYSTEM PARTS

**BP-1
1/2 OZ PUMP
88388**

*Pump is preset to deliver 1/2 fl oz portions.
(A large gaging collar is attached to head assembly.)*

**HEAD ASSEMBLY
88386**

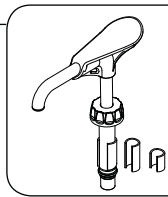

SPRING



CYLINDER ASSEMBLY

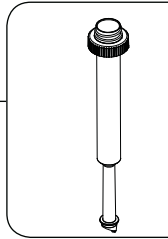

GAGING COLLAR(S)

Add to head assembly to reduce portion size.

Collar(s) Used	Portion Result
None	1 fl oz
Medium	3/4 fl oz
Large	1/2 fl oz
Medium + Large	1/4 fl oz

LID-

- Chocolate 88352
- Caramel 88367
- White Chocolate 88368
- Vanilla 89238
- Sea Salt Caramel 89241

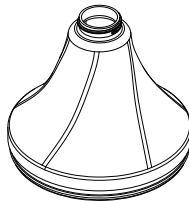

BASE-

- Chocolate 88376
- Caramel 88377
- White Chocolate 88379
- Vanilla 89237
- Sea Salt Caramel 89243



**FOOD EQUIPMENT LUBRICANT
40179**

**11" BRUSH
82049**

**21" BRUSH
84257**

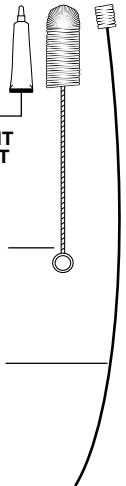

**SCRAPER
87022**

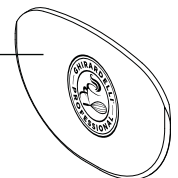

ASSEMBLY



PRACTICE SAFETY. WASH ALL PARTS PROPERLY BEFORE USE. See page 6.

SEE SEPARATE PUMP MANUAL FOR PUMP ASSEMBLY INSTRUCTIONS.

1 ATTACH PUMP TO LID

Screw pump cap onto lid threading to secure.

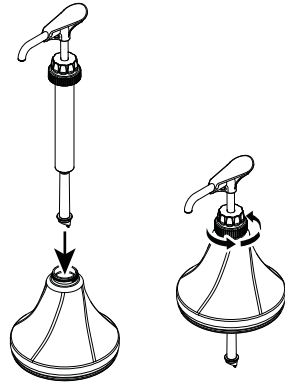

2 ATTACH PUMP TO POUCH

- Place sauce pouch on countertop with pouch fitment circle facing upward.
- Position pump connector directly over center of pouch fitment.
- Press pump connector down to pierce through film in pouch fitment.
- Pump connector is fully engaged when top surface of pouch fitment touches pump connector rim.

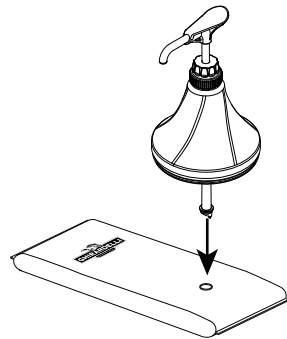

3 INSERT PUMP, LID & POUCH COMBINATION INTO BASE

Loosely fold pouch around bottom of pump while inserting into base.

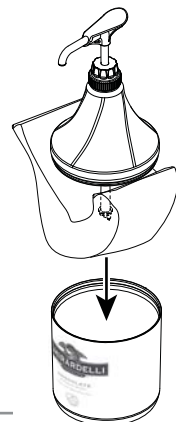

4**PUSH LID DOWN**

onto base.
Snap into position to secure.

**5****PRIME PUMP**

Press pump several times until sauce
is dispensed.



MAXIMIZE POUCH EVACUATION

**WHEN SAUCE POUCH SEEMS EMPTY
(AFTER PUMPING), USE POUCH SCRAPER.**

1

**REMOVE PUMP, LID &
POUCH COMBINATION
FROM BASE**

2

STRETCH POUCH FLAT
on countertop.

3

USE SCRAPER
to push sauce towards pump and
maximize evacuation from pouch.

4

**RETURN PUMP, LID &
POUCH FOR OPERATION**

5

**DISPENSE UNTIL ALL
REMAINING SAUCE
IS EVACUATED FROM
POUCH**

Completely empty pouch may
be discarded.

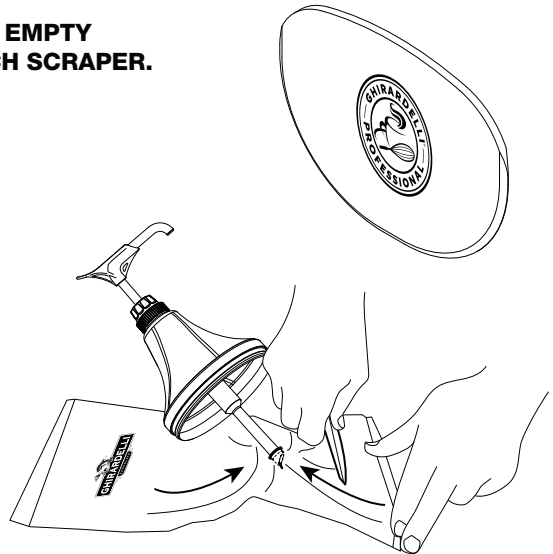

UNIT TAKE-DOWN

- 1 REMOVE PUMP, LID & POUCH**
from shroud.

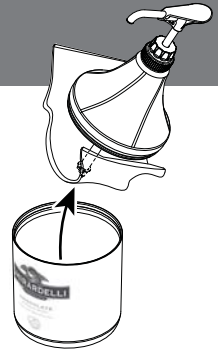

- 2 REMOVE POUCH**
from pump.
Completely empty pouch
may be discarded.

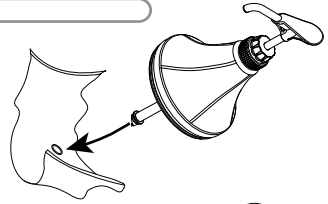

- 3 REMOVE PUMP**
from lid. Loosen cap from
lid threads to release.

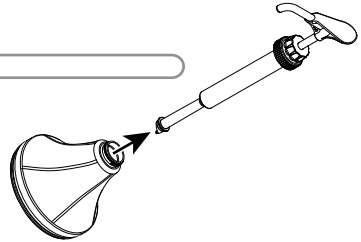

- 4 DISASSEMBLE & CLEAN PUMP**
See separate Pump Manual.

CLEANING

**SEE SEPARATE PUMP MANUAL
FOR PUMP INSTRUCTIONS.**



YES!

**Use dishwashing
soap and hot water
to clean lid and base.**

DO NOT IMMERSE BASE IN WATER

- A general purpose, nonabrasive cleaner may be used on hard to remove deposits.
- Do not use abrasive, caustic or ammonia based cleansers.
- Do not use cleansing agents with high concentrations of acid, alkaline or chlorine.
- Do not use metal scrapers or cleaning pads that could scratch surfaces.

TROUBLESHOOTING

PRODUCT OOZES OUT FROM LOCKING COLLAR?

- Ensure that the **cap** is securely snapped into place below all the threading on the cylinder.

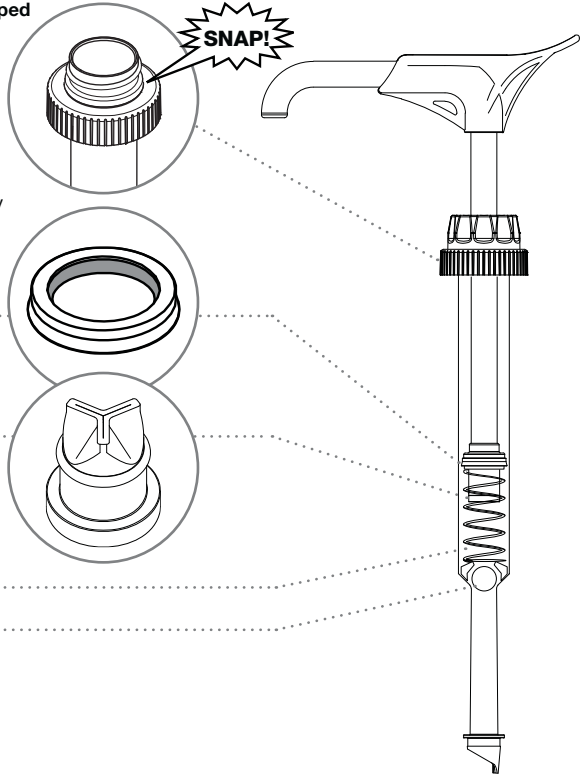

INCONSISTENT PORTIONS?

- Clean pump.
- Ensure product container is not empty and has **enough product** to pump.
- Ensure unit is **assembled correctly**.
TIP: Seal has a slight taper...
Install with flat side towards top, flared side down.
- Ensure **pinch valve** is installed correctly...
TIP: Squeeze the pinch valve open before installation to ensure it isn't stuck shut.
- Ensure that the **spring** is functional. Replace broken spring if necessary.
- Ensure that the **stainless steel ball** is snapped in place below tabs.

SERVER PRODUCTS LIMITED WARRANTY

2
YEAR
WARRANTY



Server Products equipment is backed by a two-year limited warranty against defects in materials and workmanship.

For complete warranty information go to:

www.Server-Products.com

GENERAL SERVICE, REPAIR OR RETURNS

Before sending any item to Server Products for service, repair, or return, contact Server Products customer service to request a **Return Authorization Number**. Merchandise must be sent to Server Products with this number. Service is extremely prompt. Typically, units are repaired and ship out within 48 hours of receipt.

Merchandise being returned for credit must be in new and unused condition and not more than 90 days old and will be subject to a 20% restocking charge.

NEED HELP?

Server Products Inc.

3601 Pleasant Hill Road
Richfield, WI 53076 USA



262.628.5600 | 800.558.8722



SPSALES@SERVER-PRODUCTS.COM

Please be prepared with your **Series Number** and **Description** located on the unit.

Please refer to page 3 for individual **Part Numbers**.