



S E R V E R

SERVE BETTER™



## French's Express

MODEL: RE

Used with pouches up to  
1½ gallons with 16mm fitments.

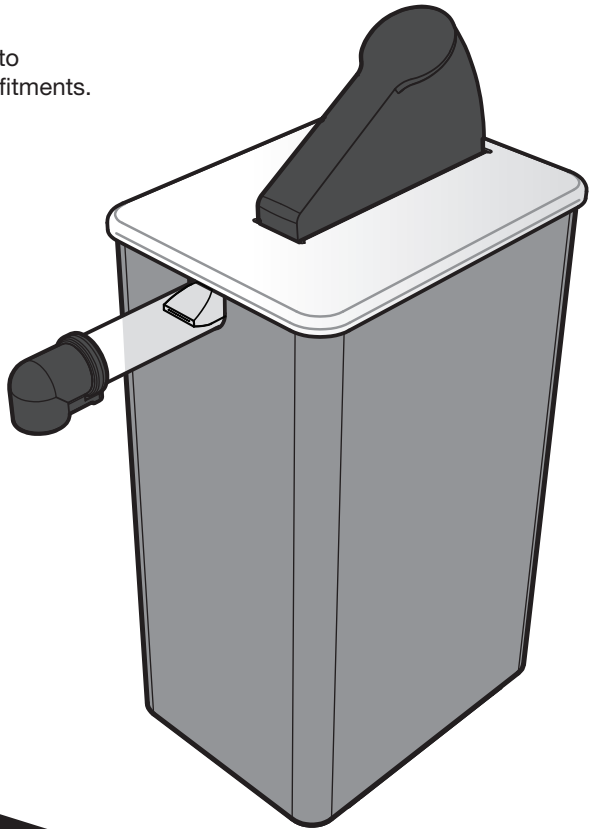
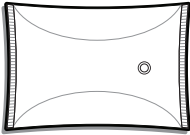

### **Thank You**

...for purchasing our Server Express™ Pouched Condiment Dispenser. This portion controlled unit is sealed and sanitary, achieves excellent evacuation and has only a few parts for easy clean-up.

SIMPLIFY CONDIMENT MANAGEMENT — GO POUCHED

# PARTS

## COMPLETE UNITS:

Cattlemen's BBQ Sauce  
**07622**

French's Honey Mustard Dipping Sauce  
**07675**

Frank's Red Hot Buffalo Wings Sauce  
CANADA  
**07721**

Cattlemen's BBQ Sauce  
CANADA  
**07722**

French's Classic Yellow Mustard  
CANADA  
**07724**

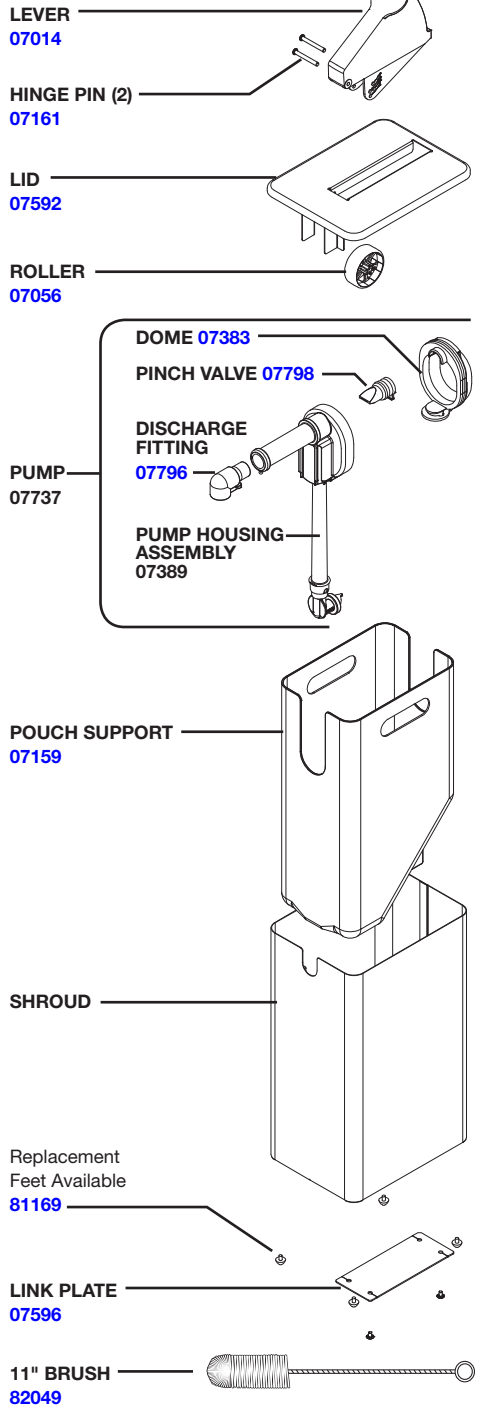

# SAFETY



According to food and safety regulations, most foods must be stored and/or served at certain temperatures or they could become hazardous. Check with local food and safety regulators for specific guidelines. Server Products, Inc. cannot be responsible for the serving of potentially hazardous product.

## IMPORTANT

**Clean, rinse, sanitize, and dry parts daily or regularly to comply with local sanitization requirements.**



NSF International lists this pump as:  
"Not acceptable for dispensing potentially hazardous foods."

ADA  
compliant

# LINKING MULTIPLE UNITS

Use supplied link plate and screws to link units together. Link plate is secured to bottom of each unit.

## 1 REMOVE LIDS, PUMPS AND POUCH SUPPORTS

from shrouds.

## 2 TURN SHROUDS UPSIDE DOWN

Align shrouds next to each other, facing the same way.

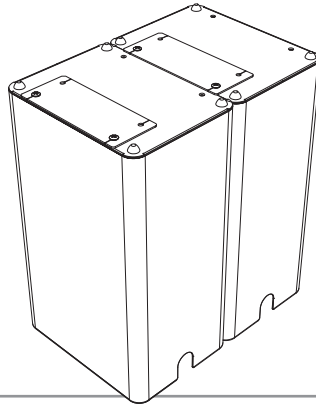

## 3 REMOVE THE TWO SCREWS

which secure the link plate to the bottom of each shroud.

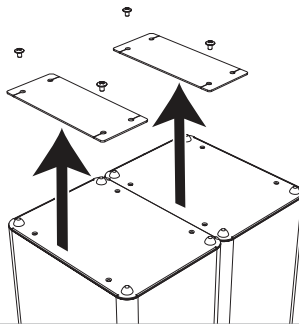

## 4 ALIGN THE FOUR HOLES

in link plate with the four holes in the pair of shrouds. **Only one plate is required to link together two units.**

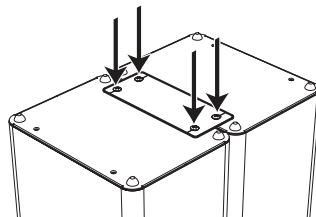

## 5 SECURE UNITS TOGETHER

Use all four screws to affix link plate to shrouds.

# PUMP ASSEMBLY

WASH ALL PARTS  
PROPERLY BEFORE USE. See page 7.

## 1 INSERT PINCH VALVE

into pump housing.

*TIP: Squeeze the pinch valve open before installation to ensure it isn't stuck shut.*

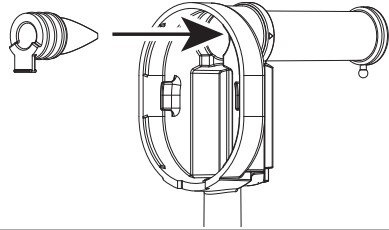

## 2 INSTALL DOME

Slide loop of dome up the housing tube.

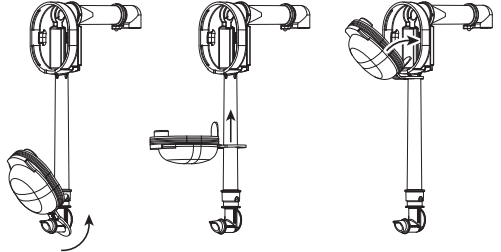

Press dome into housing fully.  
Ensure valve flap covers bottom opening.

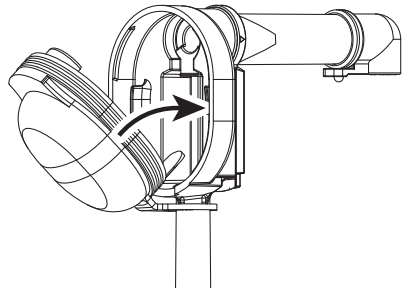

## 3 INSERT DISCHARGE FITTING

into pump housing discharge tube.  
Place loop of fitting around peg on end of discharge tube to secure.

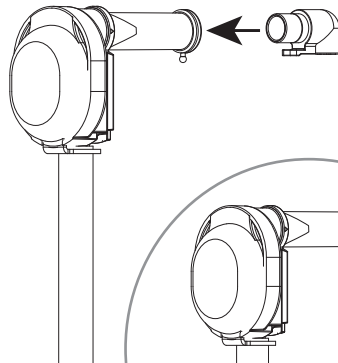

# UNIT SETUP

WASH ALL PARTS  
PROPERLY BEFORE USE. See page 7.

## 1 ATTACH POUCH TO PUMP

Firmly press piercing connector into center of pouch fitment.  
An audible click indicates a secure connection.

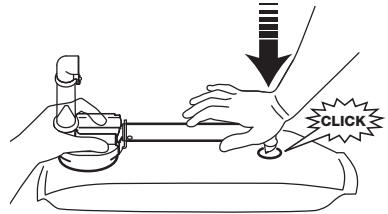

## 2 INSTALL PUMP

Slide pouch and pump into pouch support within shroud.  
Align pump guides into slots in shroud.

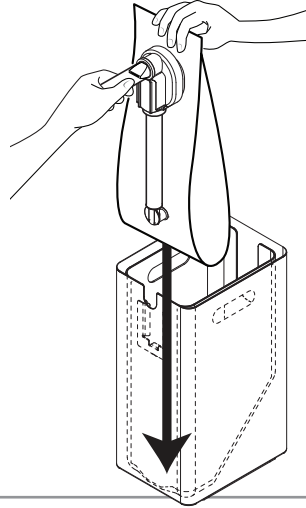

## 3 PLACE LID ON TOP

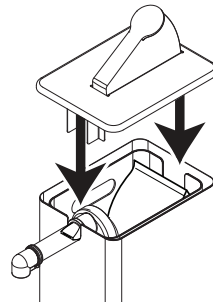

## 4 PRIME PUMP

Press lever several times until you see product in discharge tube.

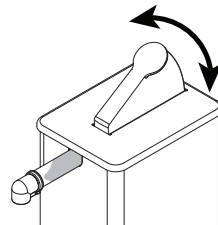

# PORTION CONTROL

**THE LID IS SET TO DELIVER 1 OZ PORTIONS.**

If lid reassembly is needed,  
or to specify a different portion size:

One hinge pin attaches lever to lid.

Second hinge pin attaches roller to lever.  
(Controls portion dispensed.)

Install hinge pin through center  
roller hole and desired portion  
hole on lever.

Pin snaps into place.

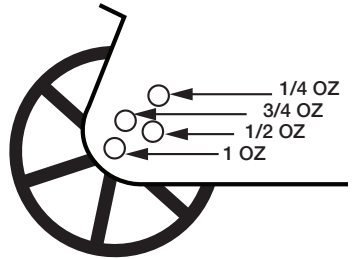
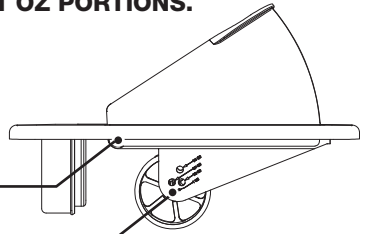

## TAKE-DOWN & DISASSEMBLY

**1 REMOVE LID**

**2 REMOVE PUMP & POUCH**

**3 DETACH PUMP FROM POUCH**

**4 FLUSH & RINSE PUMP**

Place lower end of pump into container of hot water. Pump until all remaining product is expelled and only water flows from discharge tube.

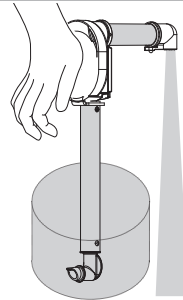

**5 DISASSEMBLE**

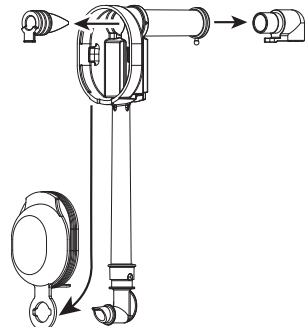

# CLEANING

## PUMP CLEANING

- 1 FLUSH & RINSE**  
all pump surfaces with hot water.  
Place lower end of pump into container of hot water and operate pump until all remaining product is expelled and only hot water is discharged.
- 2 DISASSEMBLE & CLEAN**  
all washable parts with soap and hot water.  
Use brush to clean any confined areas.
- 3 RINSE**  
fully with clear water.
- 4 SANITIZE**  
all parts according to local sanitization requirements. All parts in contact with food must be sanitized.
- 5 AIR DRY**  
all parts fully.



## YES!

### Use dishwashing soap, hot water and nylon brush

- Pump is dishwasher safe
- Do not use abrasive, caustic or ammonia based cleansers.
- Do not use cleansing agents with high concentrations of acid, alkaline or chlorine.
- Do not use metal scrapers or cleaning pads that could scratch surfaces.

## UNIT CLEANING

- External surfaces may be wiped clean with a clean damp cloth.
- Glass and surface cleaners approved for use in food contact areas may be used.
- Do not use abrasive, caustic or ammonia based cleansers.
- Do not use metal scrapers or cleaning pads that could scratch surfaces.

# CARE OF STAINLESS STEEL

This unit is constructed with stainless steel— one of the best materials for food serving and storage.

If you notice corrosion beginning on any stainless steel surface, you may need to change the cleansing agent, sanitizing agent, or the cleaning procedures you are using.

- A mildly abrasive nylon or brass brush may be used to remove any stubborn food or mineral deposits on interior surfaces of unit.
- Fully rinsing and drying all parts can help prevent corrosion. Elements and minerals in tap water can accumulate on stainless steel parts and create corrosion.
- Do not use products containing acids, alkalines, chlorine, or salt. These agents can corrode stainless steel.

# TROUBLESHOOTING

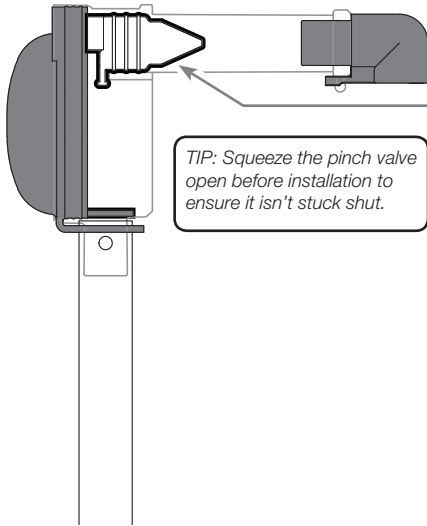

## DIFFICULT TO ATTACH PARTS?

- Wet parts with clean water to help fit.

## PRODUCT DOESN'T PUMP?

- Ensure pinch valve is inserted in housing.
- Ensure connector is snapped fully in place to fitment in pouch.
- Ensure pump is properly attached to pouch.
- Clean pump thoroughly.
- Ensure pump is properly installed into retaining slots inside front wall of shroud.

## DOMES POPS OFF?

- Clean thoroughly. Food residue could prevent a tight seal between dome and housing.
- Ensure dome edges are flush with housing.

## SERVER PRODUCTS LIMITED WARRANTY

**2**  
YEAR  
WARRANTY



Server Products equipment is backed by a two-year limited warranty against defects in materials and workmanship.

For complete warranty information go to:

[www.Server-Products.com](http://www.Server-Products.com)

## GENERAL SERVICE, REPAIR OR RETURNS

Before sending any item to Server Products for service, repair, or return, contact Server Products customer service to request a **Return Authorization Number**. Merchandise must be sent to Server Products with this number. Service is extremely prompt. Typically, units are repaired and ship out within 48 hours of receipt.

Merchandise being returned for credit must be in new and unused condition and not more than 90 days old and will be subject to a 20% restocking charge.

## NEED HELP?

### Server Products Inc.

3601 Pleasant Hill Road  
Richfield, WI 53076 USA



262.628.5600 | 800.558.8722



[SPSALES@SERVER-PRODUCTS.COM](mailto:SPSALES@SERVER-PRODUCTS.COM)

Please be prepared with your **Model, Part, Series Number** and **Description**.

This information is located on the base of the unit.

Individual **Part Numbers** listed on page 2.