



SERVER

SERVE BETTER™

01570-REVI_050712_ENGLISH SOLUTION™ PUMPS INSTRUCTION MANUAL

Go to server-products.com for translations and for each pump parts breakdowns

PARTS INCLUDED VARY DEPENDING ON PUMP

SOLUTION™ PUMP PARTS

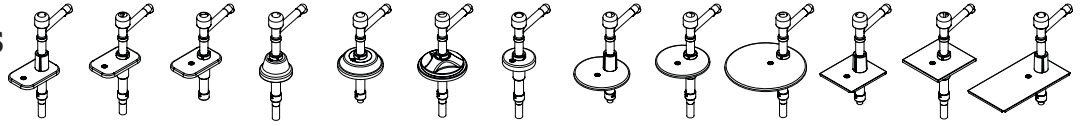

DISCHARGE FITTINGS

KNOB

DISCHARGE TUBE

LOCKING COLLARS

GAGING COLLARS

(Portion Control) Each collar added reduces portion served by .25 oz

BALL VALVE

PISTON

SEAL

SPRING

LIDS

CYLINDER

BALL VALVE

CONNECTORS

SUCTION TUBES

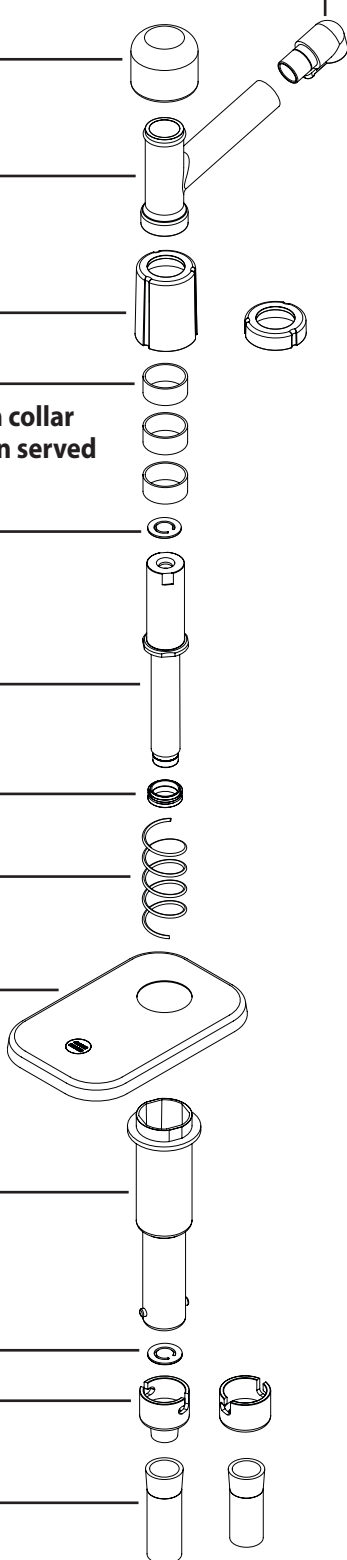

FOOD EQUIPMENT LUBRICANT 40179

BRUSH 82049 (1 1/4" D)

BRUSH 82526 (21")

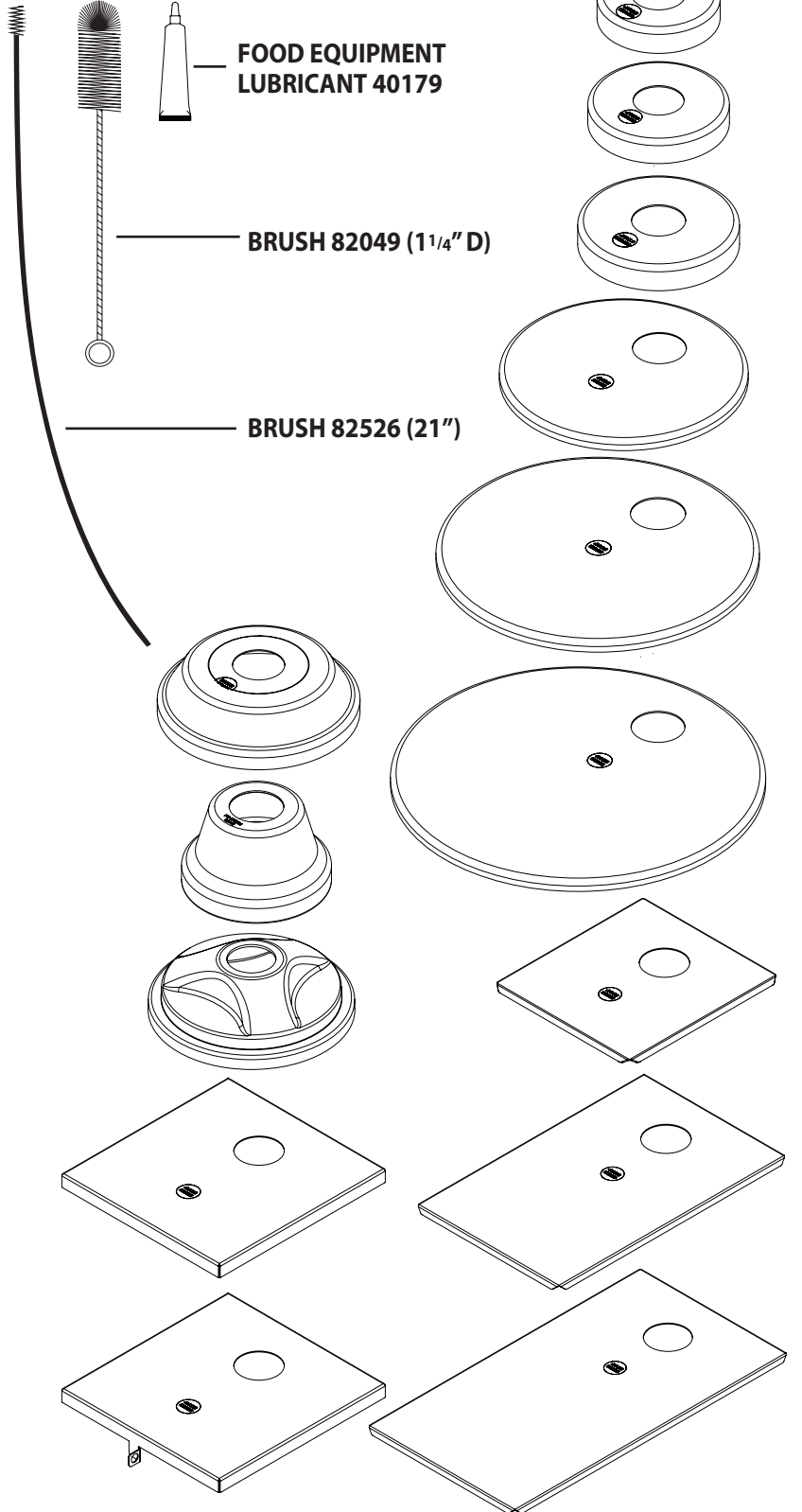

PUMP DISASSEMBLY

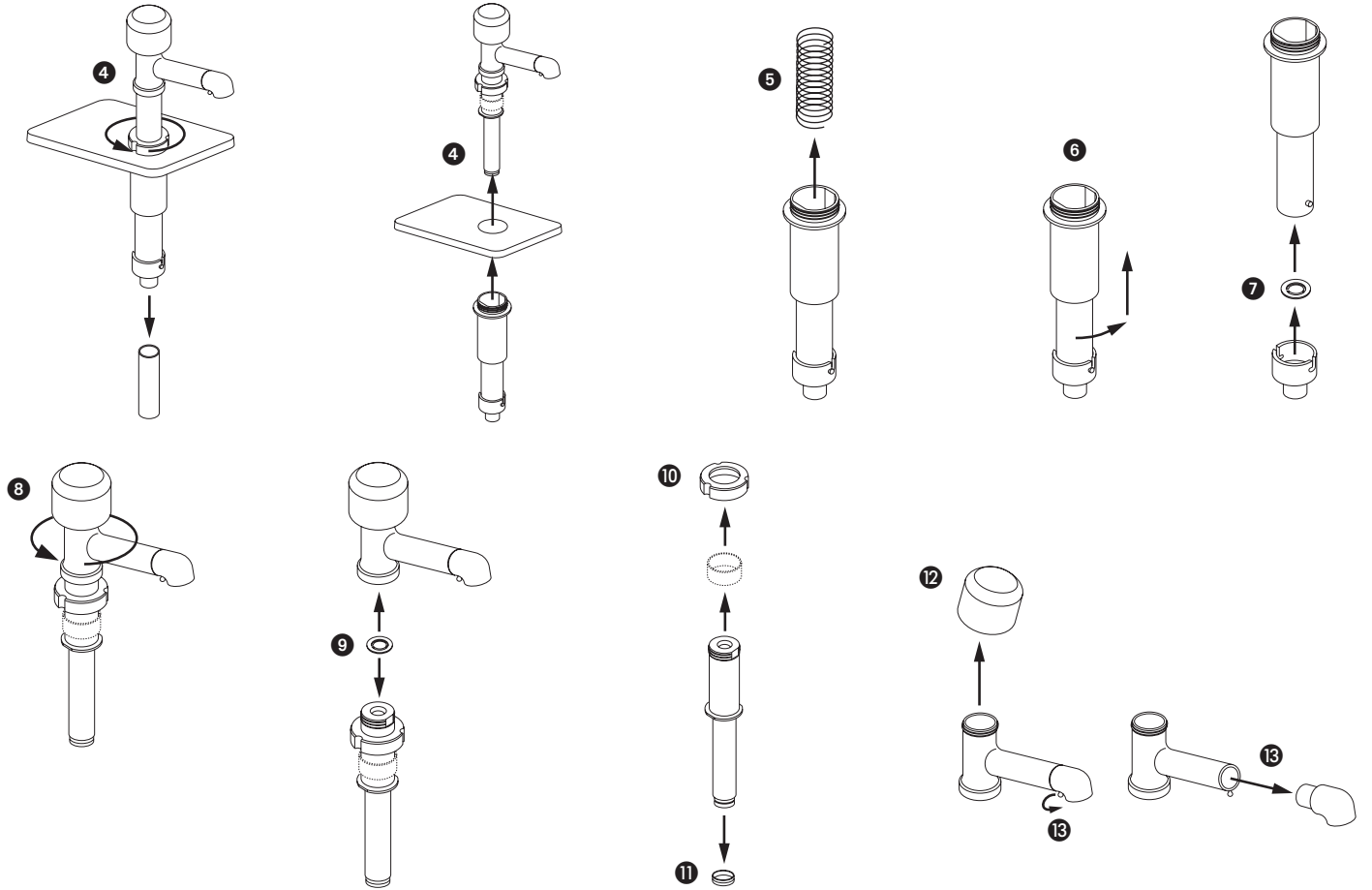

PUMP ASSEMBLY

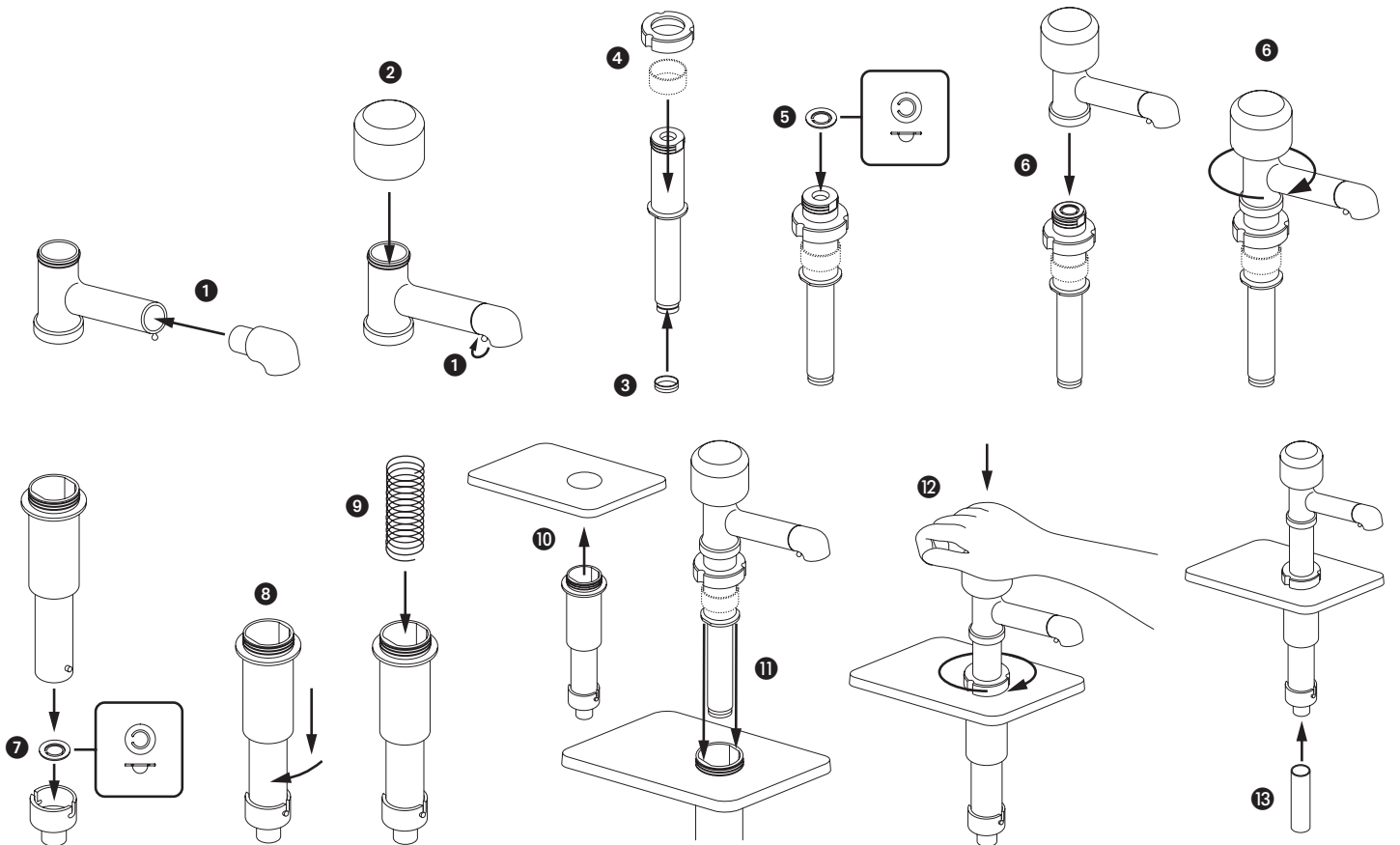

PUMP DISASSEMBLY

BEFORE FIRST USE AND AFTER USE DAILY, DISASSEMBLE AND CLEAN PUMP.

- 1 PUMP OUT ALL (IF ANY) REMAINING FOOD PRODUCT FROM INSIDE PUMP BODY.
- 2 WASH AND RINSE OFF OUTSIDE OF PUMP BODY.
- 3 FLUSH OUT AND RINSE THROUGH INSIDE OF PUMP.
 - Place lower end of pump into container full of water and operate pump until all (if any) remaining product is expelled and only warm water flows from discharge tube. Then remove pump from container of water to disassemble.
 - Use a container to collect small parts of pump to prevent any loss.
- 4 REMOVE PLUNGER ASSEMBLY AND LID FROM PUMP BODY BY TURNING LOCKING COLLAR COUNTERCLOCKWISE.
- 5 REMOVE SPRING FROM PUMP BODY.
- 6 REMOVE CYLINDER FROM CONNECTOR. PUSH CYLINDER INTO CONNECTOR TO COMPRESS BALL VALVE WHILE ROTATING CYLINDER COUNTERCLOCKWISE. ROTATE CYLINDER TO RELEASE PINS FROM SLOTS ON CONNECTOR.
- 7 REMOVE BALL VALVE FROM INSIDE CONNECTOR.
- 8 REMOVE DISCHARGE TUBE BODY FROM PISTON BY ROTATING DISCHARGE TUBE BODY COUNTERCLOCKWISE.
 - Be prepared for ball valve to fall loose when removing discharge tube body from piston.
- 9 REMOVE BALL VALVE FROM PISTON, IF REMAINING ON END OF PISTON.
- 10 REMOVE LOCKING COLLAR AND GAGING COLLAR(S), IF USED, FROM PISTON BY SLIDING THEM OFF.
- 11 REMOVE SEAL FROM END OF PISTON BY ROTATING AND PULLING OFF OF LIP ON PISTON.
- 12 REMOVE KNOB FROM DISCHARGE TUBE BODY BY PULLING KNOB AT AN ANGLE UNTIL KNOB FLANGES RELEASE FROM LIP ON DISCHARGE TUBE BODY.
- 13 REMOVE DISCHARGE FITTING FROM DISCHARGE TUBE BY RELEASING FITTING LOOP AND PULLING FITTING AWAY FROM DISCHARGE TUBE.
 - DO NOT USE FITTING LOOP ON DISCHARGE FITTING AS A PULL.

PUMP CLEANING

BEFORE FIRST USE AND AFTER USE DAILY, DISASSEMBLE AND CLEAN PUMP.

STAINLESS STEEL PARTS CAN CORRODE.

IT IS IMPORTANT TO CLEAN, RINSE, SANITIZE, AND DRY THESE PARTS DAILY AND PROPERLY. FAILURE TO COMPLY WITH ANY OF THESE INSTRUCTIONS MAY VOID UNIT WARRANTY.

- 1 SEE PUMP DISASSEMBLY.
- 2 WASH AND SCRUB ALL PARTS WITH DISHWASHING DETERGENT AND HOT WATER DAILY.
 - **Wash small parts in a pan or other container to prevent part loss.**
 - **Use supplied brushes to clean all confined areas. Maintain a clean and efficient pump by using the brushes supplied with pump to prevent product build up inside pump.**
 - Do not use abrasive cleansers, scrapers, steel pads, steel wool, or other cleaning tools that can scratch surfaces.
 - A general purpose, nonabrasive cleaner may be used on hard to remove food deposits.
 - Do not use cleansing agents with high concentrations of acid, alkaline or chlorine. These agents can corrode stainless steel.
 - Do not use ammonia to clean pump parts. Ammonia can damage plastic parts.
 - A nontoxic glass cleaner may be used for cleaning any stainless steel parts.
- 3 FULLY RINSE ALL PARTS THOROUGHLY WITH CLEAR WATER.
 - Fully rinsing all parts can help prevent corrosion.
- 4 DRY ALL STAINLESS STEEL PARTS WITH A CLEAN SOFT CLOTH.
 - Various elements and minerals, such as chlorides in tap water, can accumulate on stainless steel parts and create corrosion.
 - To prevent corrosion on any stainless steel parts, it is important to fully dry with a clean soft cloth regularly.
- 5 SANITIZE PARTS FOLLOWING YOUR LOCAL SANITIZATION REQUIREMENTS. ALL PARTS IN CONTACT WITH FOOD MUST BE SANITIZED.
 - Allow parts to fully air dry after sanitization.
 - Dishwasher safe.

PUMP ASSEMBLY

BEFORE FIRST USE AND AFTER USE DAILY, DISASSEMBLE AND CLEAN PUMP.

- 1 INSTALL DISCHARGE FITTING INTO DISCHARGE TUBE. SECURE DISCHARGE FITTING TO TUBE BY HOOKING FITTING LOOP AROUND PROJECTION ON END OF DISCHARGE TUBE.
- 2 INSTALL KNOB ONTO TOP OF DISCHARGE TUBE BODY BY PUSHING TOGETHER UNTIL KNOB SNAPS ONTO LIP OF DISCHARGE TUBE BODY.
- 3 INSTALL SEAL ONTO BOTTOM OF PISTON. SEAL IS SECURE WHEN IT SNAPS ONTO LIP AROUND BOTTOM OF PISTON.
- 4 INSTALL GAGING COLLAR(S), IF NEEDED, AND LOCKING COLLAR ONTO THREADED END OF PISTON BY SLIDING THEM ON. POSITION LOCKING COLLAR WITH THREADING INSIDE LOCKING COLLAR FACING SEAL AT BOTTOM OF PISTON.
- 5 INSTALL ONE OF THE BALL VALVES WITH BALL SIDE SEATED DOWN INTO OPENING IN TOP OF PISTON.
- 6 INSTALL BOTTOM OF DISCHARGE TUBE BODY ONTO THREADED TOP OF PISTON WITH BALL VALVE IN POSITION RESTING ON TOP OF PISTON. ROTATE DISCHARGE TUBE BODY CLOCKWISE UNTIL SECURE WITH PUMP TUBE ASSEMBLY.
- 7 INSTALL THE OTHER BALL VALVE WITH THE BALL SIDE SEATED DOWN INTO OPENING INSIDE CONNECTOR.
- 8 INSTALL BOTTOM END OF PUMP BODY, WITH PINS, INTO CONNECTOR WITH BALL VALVE IN POSITION RESTING INSIDE CONNECTOR. COMPRESS BALL VALVE SLIGHTLY AND ROTATE PUMP BODY INTO CONNECTOR UNTIL PINS SECURE INTO SLOTS IN CONNECTOR.
- 9 INSTALL SPRING INTO PUMP BODY.
- 10 INSTALL LID ONTO PUMP BODY BY ALIGNING LARGE HOLE IN LID TO REST ON THREADED LIP OF PUMP BODY ASSEMBLY.
- 11 INSTALL PLUNGER ASSEMBLY INTO PUMP BODY ASSEMBLY. COMPRESS PUMP AND ROTATE UNTIL FLATS ON PISTON ALIGN INTO POSITION WITH FLATS INSIDE CYLINDER.
- 12 WHILE COMPRESSING PUMP, ROTATE LOCKING COLLAR CLOCKWISE TO SECURE ONTO THREADING OF CYLINDER.
- 13 IF SUCTION TUBE IS INCLUDED, INSTALL ONTO BOTTOM OF CONNECTOR. THE SUCTION TUBE MAY BE CUT WITH SCISSORS TO THE NEEDED LENGTH.

PORTION CONTROL

After cleaning pump and during pump assembly, determine amount of product to be dispensed with each full stroke of pump. Gaging collars are included with pump to allow for changing of portion control.

- 1 INSTALL DESIRED NUMBER OF GAGING COLLARS ONTO THREADED TOP OF PUMP TUBE TO SET PORTION CONTROL.

- Each gaging collar added reduces portion per pump stroke by .25 ounces.

Portion desired per pump stroke	Number of Gaging Collars Needed	Illustration
1 Ounce	0	A
3/4 Ounce	1	B
1/2 Ounce	2	C
1/4 Ounce	3	D

- 2 COMPLETELY ASSEMBLE PUMP. SEE PUMP ASSEMBLY.

- 3 TEST PORTION CONTROL.

- Put pump in product container and operate pump several times until only product without air bubbles is delivered with each stroke of pump.
- Then measure amount of product being delivered through discharge tube with each stroke of pump to assure portion control is satisfactory.

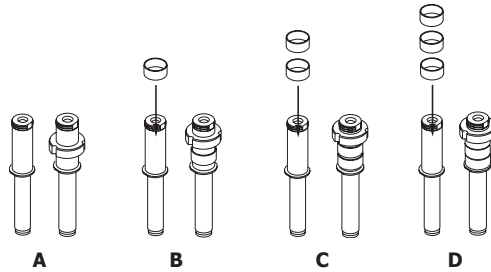

SAFETY GUIDELINES WHEN USING THIS PUMP:

According to food and safety regulations, most foods must be stored and/or served at certain temperatures or they could become hazardous. Check with your local food and safety regulators for specific guidelines.

Be aware of the product you are serving and the temperature the product is required to maintain. Server Products, Inc. can not be responsible for the serving of potentially hazardous product.

Stainless steel is one of the best materials for food serving and storage, but there are many products which can corrode it. If you notice corrosion beginning on any stainless steel surface, you may need to change the cleansing agent, sanitizing agent, or the cleaning procedures you are using.

- Products containing: acids, alkalines, chlorine, or salt can corrode stainless steel.
- Sauerkraut and Au Jus sauces corrode stainless steel. Server Products, Inc. regrets that we can not honor warranty claims on stainless steel parts that have been affected by sauerkraut or Aus Jus.

SERVER PRODUCTS LIMITED WARRANTY

All Server Products equipment is backed by a two-year limited warranty against defects in materials and workmanship. For complete warranty information go to: www.server-products.com

SCOPE OF WARRANTY

Server Products Inc. ("Server Products") warrants that, for a period of two (2) years from the date of purchase (the "Warranty Period"), the equipment manufactured by it will be free from defects in workmanship and materials provided the equipment is used in the manner and in the environment for which they were manufactured.

DISCLAIMERS AND LIMITATIONS

Other than as set forth above, Server Products specifically disclaims all express and implied warranties, including but not limited to, warranties of merchantability and/or fitness for a particular purpose or use.

This warranty does not extend to repairs or alterations undertaken without the prior written consent of Server Products or for goods that are misused, abused or neglected or if the goods are not properly stored, maintained, installed or operated.

Server Products shall not be liable for incidental, special, indirect, exemplary, punitive or consequential damages resulting from the use of the good or arising out of any breach of this warranty; including but not limited to damage to property or loss of profits or revenue.

CLAIMS ADMINISTRATION

All warranty claims must be made by calling our customer service department for a return authorization during the Warranty Period and any alleged defective unit must be returned to Server Products factory, freight prepaid.

Upon receipt of any defective unit, Server Products, at its option, may either: (i) replace any equipment proved to be defective, (ii) remedy or repair such defect or (iii) refund the purchase price of the defective equipment in the form of a credit applicable to future purchases. Server Products obligation and Buyer's sole remedy will be limited to these options. In the case of units or parts purchased by Server Products from a third-party supplier: Server Products' obligation and Buyer's sole remedy against Server Products or Server Products's suppliers shall not exceed the settlement which Server Products is able to obtain from its supplier.

TROUBLESHOOTING

PROBLEMS WITH PUMP OPERATION AND/OR FLOW:

- Clean pump.
- Replace cylinder if necessary.

PUMP DISPENSES LITTLE OR NO PRODUCT.

- Product may be too stiff or contain a solid that will not pass through pump.
- Install correct discharge fitting for product being pumped.

PRODUCT OOZES OUT AROUND LOCKING COLLAR.

- Be sure to compress pump and spring while aligning flats on piston with flats inside cylinder during assembly. Tighten locking collar with pump compressed.

PORTION CONTROL IS NOT CONSISTENT.

- Inspect gaging collar for any damage and/or proper installation.

PUMP PLUNGER DOES NOT RETURN TO TOP OF STROKE AFTER DISPENSING PRODUCT.

- Inspect spring for any damage. If bent or broken, spring may cause permanent damage to cylinder. Replace spring if necessary.

PUMP DRIPS.

- Clean discharge tube and discharge fitting with supplied cleaning brushes.
- Ensure product is not being heated by any external source(s) causing product to expand and drip from pump.

CHECK BALL VALVES AND SEAL FOR ANY DAMAGE.

REPLACE BALL VALVES AND SEAL IF NECESSARY.

- Make sure ball valves are installed correctly. Balls must be facing downward with flat of valve facing upward.

GENERAL SERVICE, REPAIR, OR RETURNS

Before sending any item to Server Products for service, repair, or return, contact Server Products customer service to request a **Return Authorization Number**. Merchandise must be sent to Server Products with this number.

Merchandise being returned for credit must be in new and unused condition and not more than 90 days old and will be subject to a 20% (percent) restocking charge. Electrical parts (thermostats, heating elements etc.) are not returnable.

Server Products maintains a fully staffed service department with highly skilled factory trained personnel. Service is extremely prompt. Under normal circumstances, a repaired unit is shipped out the day after it is received. Labor charges are reasonable.

SERVICE

Contact your dealer or Server Products Inc. customer service department for the following:

ORDERING REPLACEMENT PARTS

Be prepared to give this information:

- Model Letters/Name/Numbers
- Part Numbers- P/N
- Series Numbers/Letters
- Part Description

This information and other important data is stamped on the lid or cylinder of pumps or on the bottom or back side of every unit.

Server Products Inc.
3601 Pleasant Hill Road
Richfield, WI 53076 USA

262.628.5600

800.558.8722

262.628.5110

spsales@server-products.com

www.server-products.com