



# S E R V E R

SERVE BETTER™

## Single Dip Server

MODEL: DI-1

120V USA

**92000**

**92118 (CUSTOM)**

230V CONTINENTAL

EUROPE

**92010**

230V AUSTRALIA

**92070**

230V UNITED KINGDOM

**92230**

## Double Dip Server

MODEL: DI-2

120V USA

**92020**

230V CONTINENTAL

EUROPE

**92030**

230V AUSTRALIA

**92080**

230V UNITED KINGDOM

**92240**

## Triple Dip Server

MODEL: DI-3

120V USA

**92040**

230V CONTINENTAL

EUROPE

**92050**

230V AUSTRALIA

**92090**

230V UNITED KINGDOM

**92250**

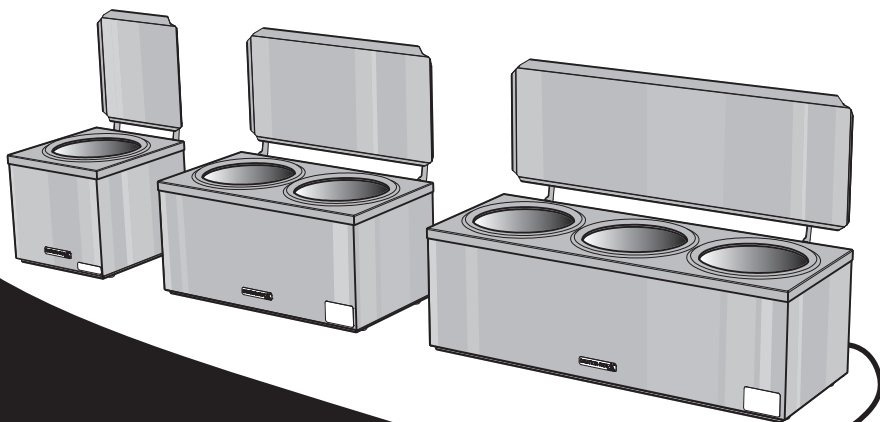

## Thank You

...for purchasing our specialty dip warmer.  
Menu additions are easy with dipped treats like soft  
serve ice cream, fresh fruit, cookies and waffle cones.

SERVE BETTER WITH CONE DIP

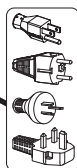

# SAFETY



## **WARNING- ELECTRICAL SHOCK COULD OCCUR**

This unit must be earthed or grounded.  
This requires all three prongs (terminals) on cord  
plug to be plugged into power source.



According to food and safety regulations, most foods must be stored and/or served at certain temperatures or they could become hazardous. Check with local food and safety regulators for specific guidelines.

**Be aware of the product you are serving and the temperature the product is required to maintain. Server Products, Inc. can not be responsible for the serving of potentially hazardous product.**



# USE

## **NOTICE**

### **DO NOT DRIP FOOD INTO KNOB AREA OR PLUG SIDE OF UNIT.**

This may damage the thermostat,  
resulting in intermittent heating.

## **DIP TEMPERATURE**

Refer to food manufacturer for recommended temperatures.

Monitor food temperature.

Unit is intended for use with cone dip and dessert products heated in temperature ranges from ambient to approximately 150° F.

Different serving models are available for toppings which require higher temperatures.

Please see page 8 for help ordering.

# PARTS

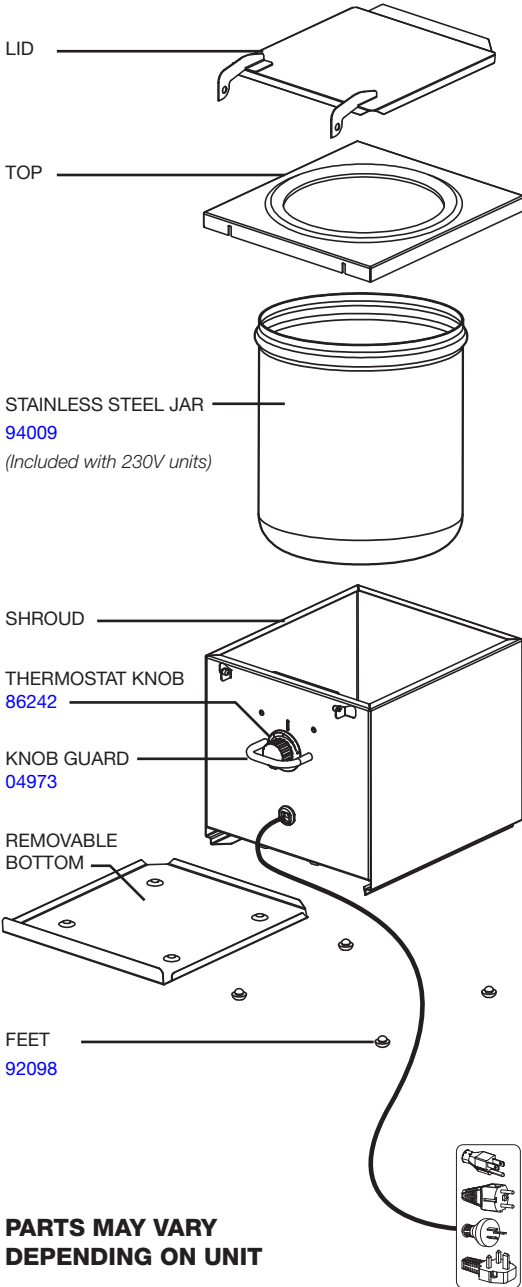

**PARTS MAY VARY  
DEPENDING ON UNIT**

## WANT ASSISTANCE?

Contact our customer service team at  
800.558.8722 or [spsales@server-products.com](mailto:spsales@server-products.com)

## LIDS

- DI-1: [92008](#)
- DI-2: [92026](#)
- DI-3: [92046](#)

## TOPS

- DI-1: [92115](#)
- DI-2: [92116](#)
- DI-3: [92117](#)

## REMOVABLE BOTTOMS

- DI-1: [92004](#)
- DI-2: [92024](#)
- DI-3: [92044](#)

## CORDS

- 120V USA
- 230V CONTINENTAL EUROPE
- 230V AUSTRALIA
- 230V UNITED KINGDOM

# UNIT SET-UP

WASH ALL PARTS PROPERLY  
BEFORE EVERY USE. See page 6.

## 1 INSERT REMOVABLE BOTTOM

into slot in base of shroud.

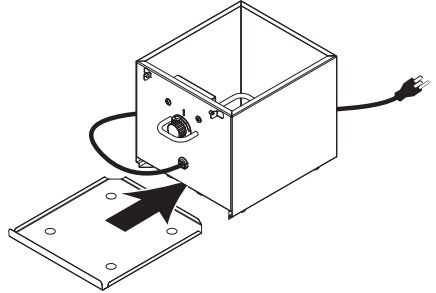

## 2 INSERT DIP CONTAINER

into shroud.

Position #10 can(s) or stainless steel jar(s)  
between bumps at bottom.

**TIP:** Stainless steel jars are  
available. Order item #94009.  
(Stainless steel jars are  
included with 230V units.)

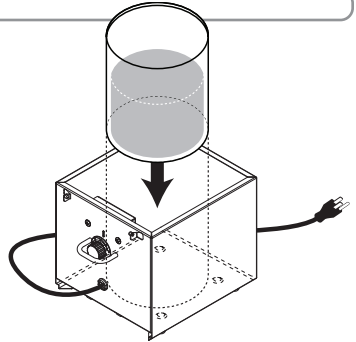

## 3 INSTALL TOP ONTO SHROUD

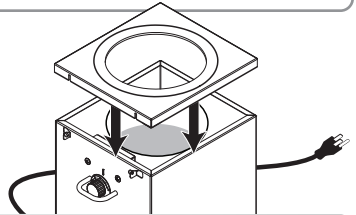

## 4 INSTALL LID ONTO SHROUD

Align lid hinge holes onto pivot pins  
on shroud.

Press lid hinges inward towards each other  
until pivot pins fit into hinge holes.

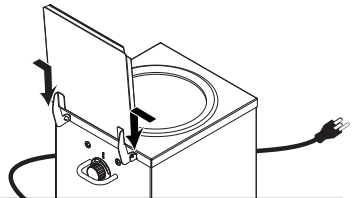

## 5 PLUG CORD into power source.

## 6 SET THERMOSTAT KNOB

to recommended serving temperature.

To heat unit faster, thermostat may  
TEMPORARILY be rotated to maximum.

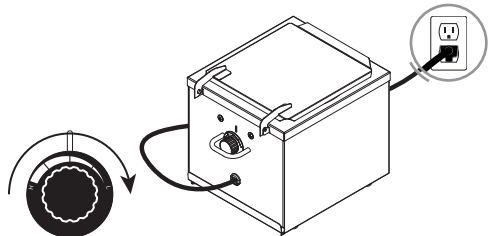

# UNIT TAKE-DOWN

## 1 ROTATE THERMOSTAT

to lowest setting.

## 2 UNPLUG CORD



## CAUTION- HOT

Allow unit to cool before continuing.

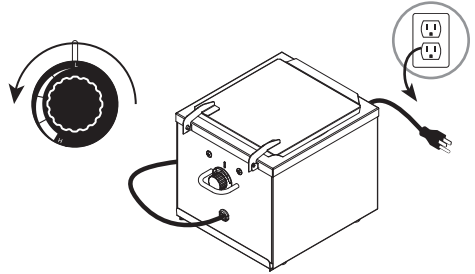

## 3 REMOVE TOP

from shroud.

**TIP:** Lid may remain attached. To detach lid for cleaning, press hinges inward towards each other until pivot pins are released from hinge holes.

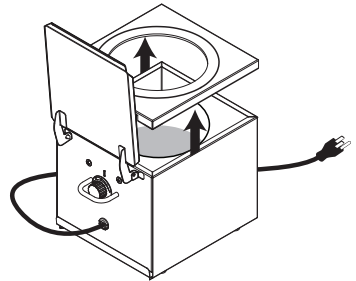

## 4 REMOVE DIP CONTAINER

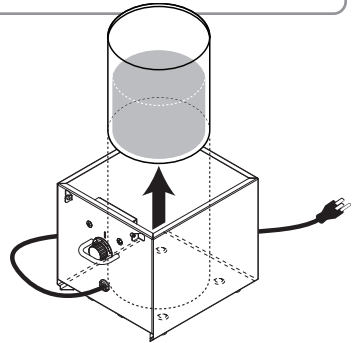

## 5 PULL REMOVABLE BOTTOM

out from slot at base of shroud.

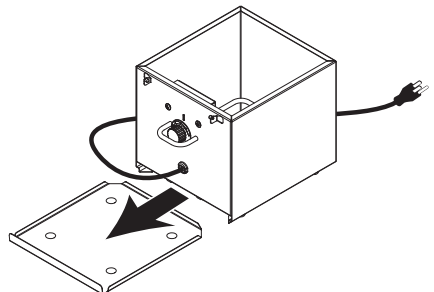

# CLEANING



## WARNING-

### ELECTRICAL SHOCK COULD OCCUR

- Electrical components of unit could be damaged from water exposure or any liquid.
- Never immerse unit into water or any liquid.
- Never use any water jet or pressure sprayer on unit.
- Ensure unit is unplugged.

## CAUTION- HOT

Allow unit to cool before cleaning.



## 1 WASH REMOVABLE PARTS

- Before first use and after use daily, disassemble and clean unit.
- Ensure unit is unplugged.
- Wash with dishwashing soap and hot water.

## 2 RINSE fully with clear water.

## 3 SANITIZE all parts according to local sanitization requirements. All parts in contact with food must be sanitized.

## 4 DRY all parts fully with a clean soft cloth.

## 5 CLEAN EXTERNAL SURFACES

- Wipe daily with a clean damp cloth.
- Dry with a clean soft cloth.
- Glass and surface cleaners approved for use in food contact areas may be used.

# CARE OF STAINLESS STEEL

This warmer and accessories are constructed of stainless steel — one of the best materials for food serving and storage.

If you notice corrosion beginning on any stainless steel surface, you may need to change the cleansing agent, sanitizing agent, or the cleaning procedures you are using.

- A mildly abrasive nylon or brass brush may be used to remove any stubborn food or mineral deposits on interior surfaces of unit.
- Fully rinsing and drying all parts can help prevent corrosion. Elements and minerals in tap water can accumulate on stainless steel parts and create corrosion.
- Do not use abrasive, caustic or ammonia based cleansers.
- Do not use products containing acids, alkalines, chlorine, or salt. These agents can corrode stainless steel.
- Do not use metal scrapers or cleaning pads that could scratch surfaces.

# WIRING

## 120V UNITS | USA

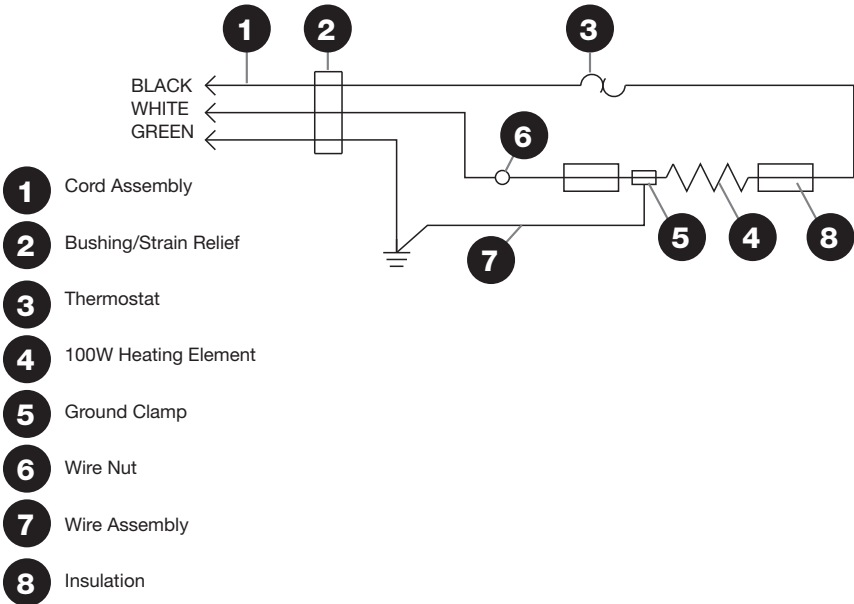

## 230V UNITS

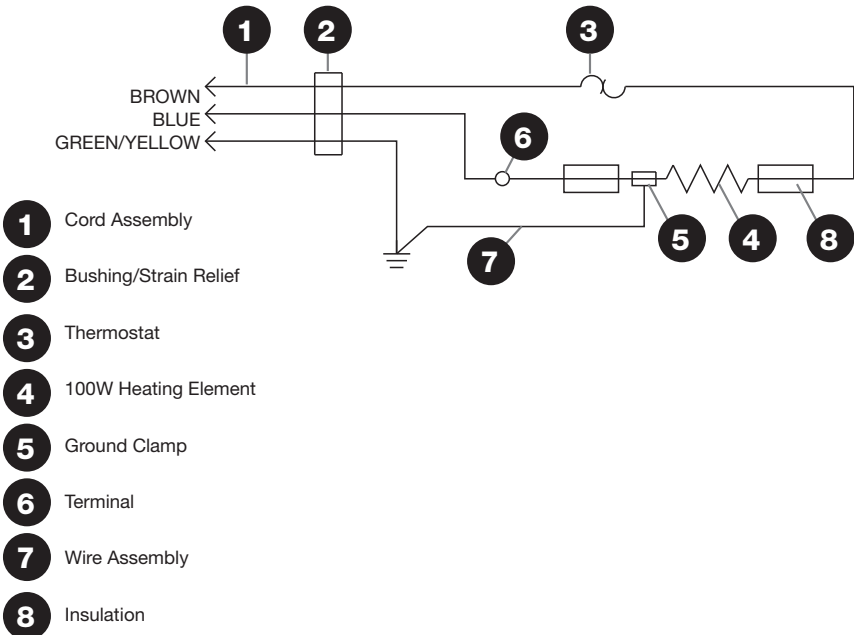

# TROUBLESHOOTING

## UNIT DOES NOT HEAT?

- Ensure cord is securely plugged in.
- Ensure power is available from source.
- Ensure unit is on.
- Ensure thermostat knob is set correctly.

## SERVER PRODUCTS LIMITED WARRANTY

**2** YEAR  
WARRANTY



Server Products equipment is backed by a two-year limited warranty against defects in materials and workmanship.

For complete warranty information go to:

[www.Server-Products.com](http://www.Server-Products.com)

## GENERAL SERVICE, REPAIR OR RETURNS

Before sending any item to Server Products for service, repair, or return, contact Server Products customer service to request a **Return Authorization Number**. Merchandise must be sent to Server Products with this number. Service is extremely prompt. Typically, units are repaired and ship out within 48 hours of receipt.

Merchandise being returned for credit must be in new and unused condition and not more than 90 days old and will be subject to a 20% restocking charge. Electrical parts (thermostats, heating elements, etc.) are not returnable.

**Service Cord:** Specific tools are required for safe and proper power supply cord removal and installation. If cord must be replaced, only a representative of the OEM (original equipment manufacturer) or a qualified technician may replace cord. Cord must meet code designation H05 RN-F requirements.

## HELP or ORDERING REPLACEMENT PARTS

### Server Products Inc.

3601 Pleasant Hill Road  
Richfield, WI 53076 USA



**262.628.5600 | 800.558.8722**



**SPSALES@SERVER-PRODUCTS.COM**

Please be prepared with your **Model, Part and Series Numbers**. This information and other important data is located on back of the unit.