



SERVER

SERVE BETTER™

# 01588-REVD\_100213\_ENGLISH PUMPS INSTRUCTION MANUAL

Go to [server-products.com](http://server-products.com) for translations and for each pump parts breakdowns

**PARTS INCLUDED VARY DEPENDING ON PUMP**

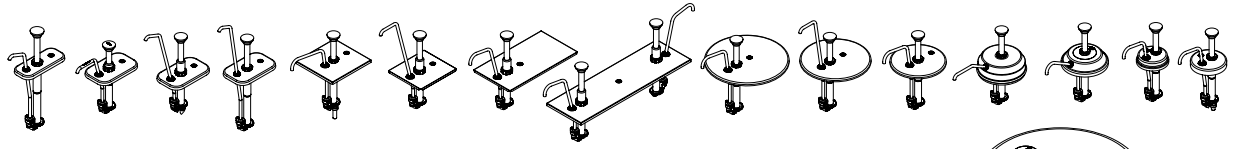

KNOBS

LOCKING COLLARS

GAGING COLLARS (Portion Control)

HEAD TUBES

HEAD INSERT

SPRINGS

WASHER

PISTONS

SEAL ASSEMBLY

DISCHARGE TUBES

DISCHARGE TUBE NUT

SEAL

SEAL O-RING

LIDS

CYLINDERS

ORIFICED PLUG (Viscosity Control)

DISCHARGE TUBE O-RING (1" D)

VALVE BODIES

SUCTION TUBE O-RING

SUCTION TUBE

Smaller gaging collar added will reduce portion served by .125 oz, larger by .25 oz

CYLINDER O-RING (1 5/16" D)

SILICONE GASKET

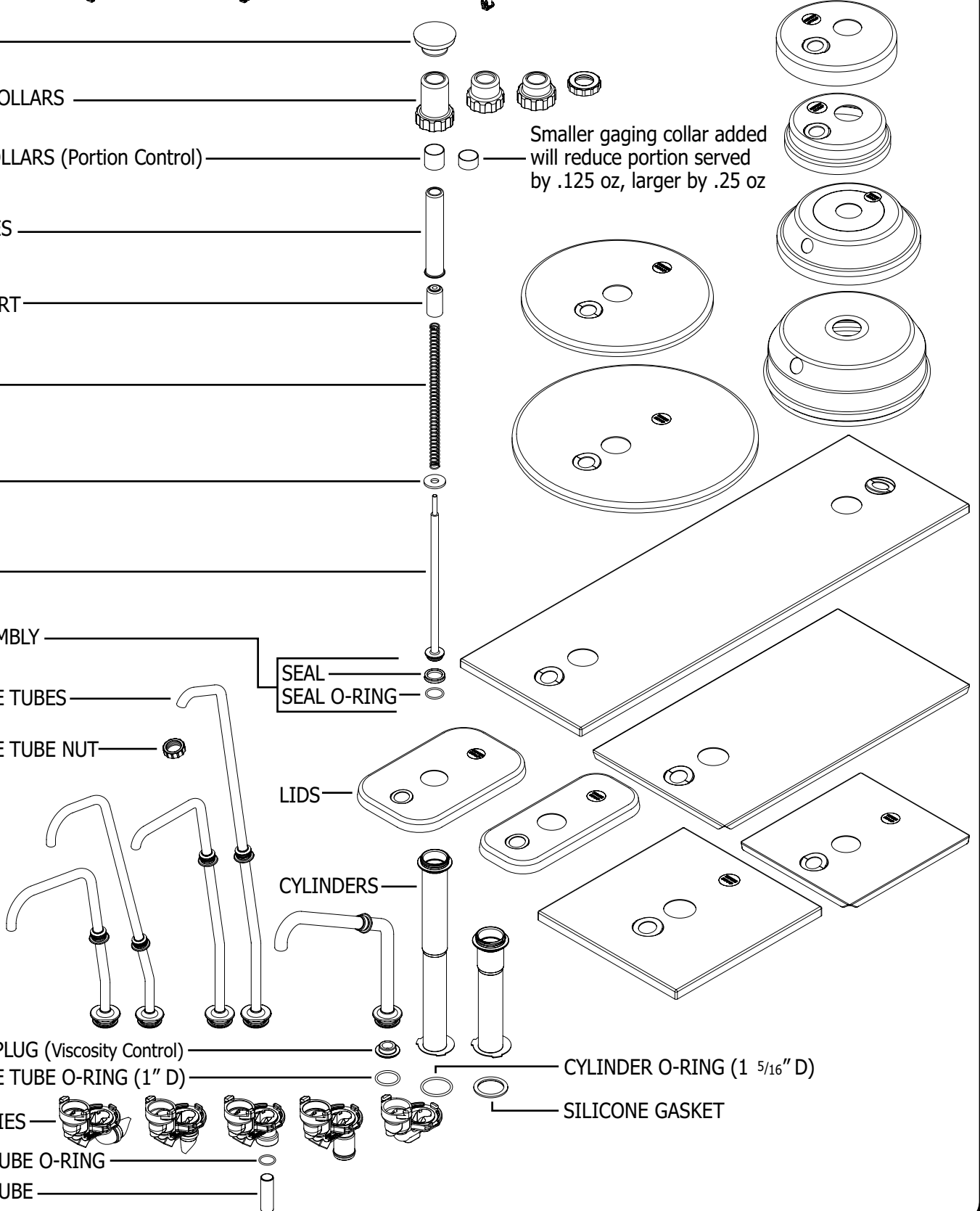

## CLEAN-IN-PLACE PROCEDURE FOR PUMPS

CLEAN-IN-PLACE IS A BASIC FOUR STEP PUMP FLUSHING PROCESS: CLEAN, RINSE, SANITIZE, AND RINSE.

### CLEAN:

- 1 PUMP OUT ALL (IF ANY) REMAINING FOOD PRODUCT FROM INSIDE PUMP.
- 2 WASH AND RINSE OFF OUTSIDE OF PUMP.
- 3 FLUSH OUT AND RINSE THROUGH INSIDE OF PUMP.
  - Place lower end of pump into container full of water and operate pump until all (if any) remaining product is expelled and only warm water flows from discharge tube.
- 4 MIX 5 ML (1 TSP) OF DISHWASHING DETERGENT (DAWN DISHWASHING LIQUID) WITH 1 QUART (.95 L) OF HOT TAP WATER (APPROXIMATELY 110°F/43°C).
- 5 PLACE LOWER END OF PUMP INTO THIS CLEANING MIXTURE AND REPEATEDLY OPERATE PUMP UNTIL ALL CLEANING MIXTURE IS PUMPED THROUGH PUMP.

### RINSE:

- 6 PLACE LOWER END OF PUMP INTO 2 CUPS (.5 L) OF HOT TAP WATER (APPROXIMATELY 110°F/43°C) AND REPEATEDLY OPERATE PUMP UNTIL ALL TAP WATER IS PUMPED THROUGH PUMP.

### SANITIZE:

- 7 MIX ONE 1 OZ (28.4 G) PACKET OF KAY-5 SANITIZER/CLEANER (EPA REG NO. 5389-15) WITH 2.5 GALLONS (9.5 L) OF TAP WATER (APPROXIMATELY ROOM TEMPERATURE).
- 8 PLACE LOWER END OF PUMP INTO THIS SANITIZING MIXTURE AND REPEATEDLY OPERATE PUMP UNTIL 1 QUART (.95 L) SANITIZING MIXTURE IS PUMPED THROUGH PUMP.

### RINSE:

- 9 PLACE LOWER END OF PUMP INTO 1 CUP (.24 L) OF HOT TAP WATER (APPROXIMATELY 110°F/43°C) AND REPEATEDLY OPERATE PUMP UNTIL ALL TAP WATER IS PUMPED THROUGH PUMP.

### CLEAN AND FLUSH PUMP WITH SOAP, SANITIZER, AND HOT WATER

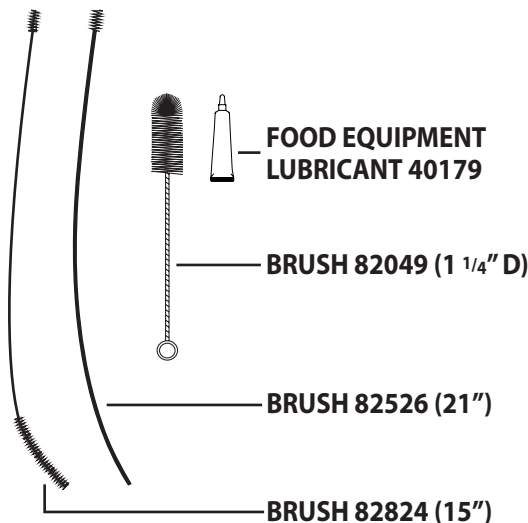
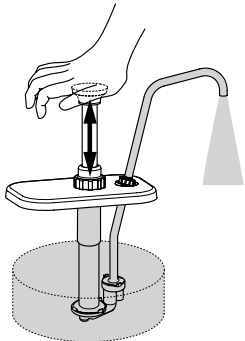

## PUMP DISASSEMBLY

BEFORE FIRST USE AND AFTER USE DAILY, DISASSEMBLE AND CLEAN PUMP.

- 1 PUMP OUT ALL (IF ANY) REMAINING FOOD PRODUCT FROM INSIDE PUMP.
- 2 WASH AND RINSE OFF OUTSIDE OF PUMP.
- 3 FLUSH OUT AND RINSE THROUGH INSIDE OF PUMP.
  - Place lower end of pump into container full of water and operate pump until all (if any) remaining product is expelled and only warm water flows from discharge tube. Then remove pump from container of water to disassemble.
  - Use a container to collect small parts of pump to prevent any loss.
- 4 REMOVE PLUNGER AND LID FROM PUMP CYLINDER BY TURNING LOCKING COLLAR AND DISCHARGE TUBE NUT COUNTERCLOCKWISE.
- 5 REMOVE CYLINDER AND DISCHARGE TUBE FROM VALVE BODY BY ROTATING COUNTERCLOCKWISE TO RELEASE FROM SLOTS IN VALVE BODY.
- 6 REMOVE LARGE O-RING OR SILICONE GASKET FROM VALVE BODY.
- 7 REMOVE SMALL O-RING FROM DISCHARGE TUBE.
  - Be careful not to damage o-ring when prying it off of discharge tube.
- 8 REMOVE KNOB FROM PLUNGER BY ROTATING COUNTERCLOCKWISE.
  - Firmly hold head tube towards piston head while unscrewing knob. Pressure on spring will release and push knob off rapidly.
- 9 REMOVE LOCKING COLLAR FROM HEAD TUBE.
  - Remove gaging collar(s), if used, from head tube by sliding them off.
- 10 REMOVE HEAD INSERT FROM INSIDE HEAD TUBE.
- 11 REMOVE SPRING FROM PISTON.
- 12 REMOVE WASHER FROM PISTON.
- 13 REMOVE SEAL ASSEMBLY FROM PISTON HEAD.
  - Be careful not to damage seal when prying it off of piston head.
- 14 REMOVE O-RING FROM INSIDE SEAL.
  - Be careful not to damage o-ring when prying it out of seal.

### IMPORTANT PUMP AREAS TO CLEAN: CLEAN ALL SIDES OF STAINLESS STEEL BALLS CLEAN VALVE BODY PASSAGEWAY CLEAN VALVE BODY OPENINGS

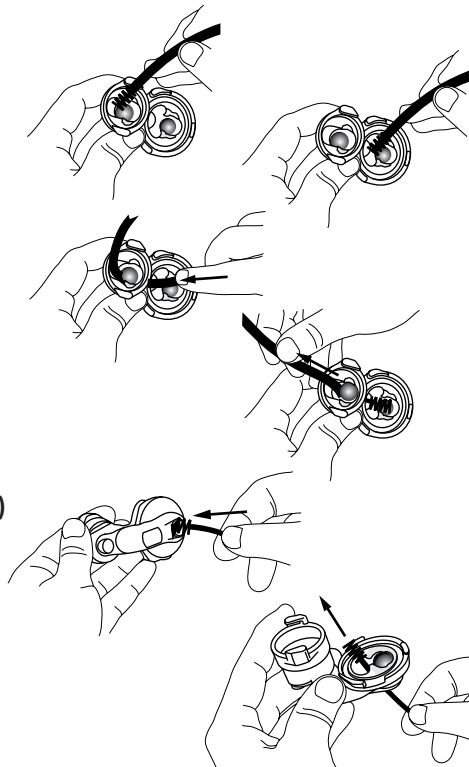

## PUMP CLEANING

BEFORE FIRST USE AND AFTER USE DAILY, DISASSEMBLE AND CLEAN PUMP.

STAINLESS STEEL PARTS CAN CORRODE. IT IS IMPORTANT TO CLEAN, RINSE, SANITIZE, AND DRY THESE PARTS DAILY AND PROPERLY. FAILURE TO COMPLY WITH ANY OF THESE INSTRUCTIONS MAY VOID UNIT WARRANTY.

- 1 SEE PUMP DISASSEMBLY.
- 2 WASH AND SCRUB ALL PARTS WITH DISHWASHING DETERGENT AND HOT WATER DAILY.
  - Wash small parts in a pan or other container to prevent part loss.
  - Use supplied brushes to clean all confined areas. Maintain a clean and efficient pump by using the brushes supplied with pump to prevent product build up inside pump.
  - IMPORTANT PUMP AREAS TO CLEAN: Clean inside cylinder thoroughly with brush 82049. Clean inside discharge tube, valve body, optional orificed plug and optional suction tube thoroughly with brush 82824 or 82526.
  - Do not use abrasive cleansers, scrapers, steel pads, steel wool, or other cleaning tools that can scratch surfaces.
  - A general purpose, nonabrasive cleaner may be used on hard to remove food deposits.
  - Do not use cleansing agents with high concentrations of acid, alkaline or chlorine. These agents can corrode stainless steel.
  - Do not use ammonia to clean pump parts. Ammonia can damage plastic parts.
  - A nontoxic glass cleaner may be used for cleaning any stainless steel parts.
- 3 FULLY RINSE ALL PARTS THOROUGHLY WITH CLEAR WATER.
  - Fully rinsing all parts can help prevent corrosion.
- 4 DRY ALL STAINLESS STEEL PARTS WITH A CLEAN SOFT CLOTH.
  - Various elements and minerals, such as chlorides in tap water, can accumulate on stainless steel parts and create corrosion.
  - To prevent corrosion on any stainless steel parts, it is important to fully dry with a clean soft cloth regularly.
- 5 SANITIZE PARTS FOLLOWING YOUR LOCAL SANITIZATION REQUIREMENTS. ALL PARTS IN CONTACT WITH FOOD MUST BE SANITIZED.
  - Allow parts to fully air dry after sanitization.
  - Dishwasher safe.

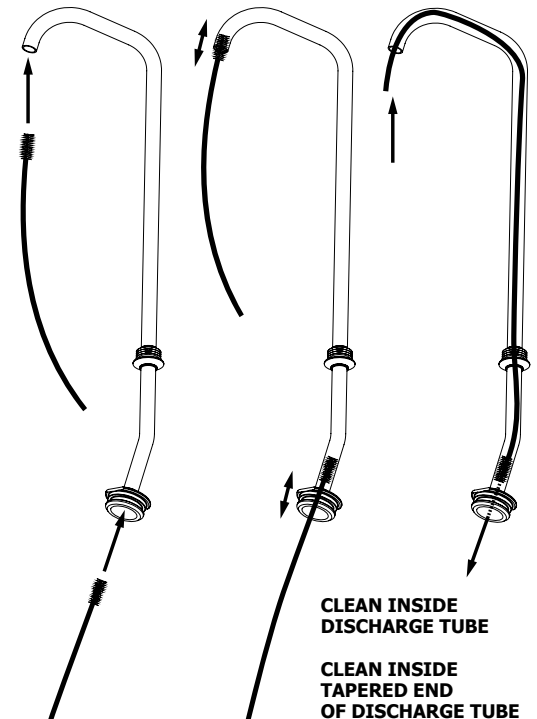

# PUMP ASSEMBLY

BEFORE FIRST USE AND AFTER USE DAILY, DISASSEMBLE AND CLEAN PUMP.

## ASSEMBLE PLUNGER:

- 1 INSTALL SEAL O-RING INSIDE SEAL.
  - Apply food equipment lubricant on seal o-ring.
- 2 INSTALL SEAL ASSEMBLY ONTO PISTON HEAD.
  - Apply food equipment lubricant inside seal assembly.
  - Flared end of seal assembly should be facing away from piston head.
- 3 INSTALL WASHER ONTO THREADED END OF PISTON.
- 4 INSTALL SPRING ONTO THREADED END OF PISTON.
- 5 INSTALL HEAD INSERT INSIDE HEAD TUBE.
  - Beveled edge of head insert should be facing inside of head tube.
- 6 INSTALL GAGING COLLAR(S), IF NEEDED, AND LOCKING COLLAR ONTO HEAD TUBE BY SLIDING THEM ON. POSITION LOCKING COLLAR WITH THREADING INSIDE LOCKING COLLAR FACING GAGING COLLAR(S) AND/OR HEAD TUBE FLARED END.
- 7 INSTALL HEAD TUBE ASSEMBLY ONTO PISTON ASSEMBLY.
- 8 INSTALL KNOB ONTO PLUNGER AND ROTATE CLOCKWISE TO SECURE ONTO THREADED END OF PISTON.
  - Firmly hold head tube towards piston head, compressing spring, while screwing knob on.

## INSTALL O-RINGS AND ASSEMBLE PUMP BASE:

- 9 INSTALL SMALL O-RING ONTO DISCHARGE TUBE.
  - Apply food equipment lubricant on o-ring.
  - Be careful not to damage o-ring while installing and/or rolling onto discharge tube.
- 10 INSTALL LARGE O-RING OR SILICONE GASKET INTO VALVE BODY.
  - Apply food equipment lubricant on o-ring or silicone gasket.
  - Install silicone gasket with flat side facing up and toward cylinder.
- 11 INSTALL CYLINDER ONTO VALVE BODY.
  - Rotate cylinder clockwise and press down firmly to secure into slots on valve body.
- 12 INSTALL DISCHARGE TUBE ONTO VALVE BODY.
  - Rotate discharge tube clockwise and press down firmly to secure into slots on valve body.

## INSTALL LID AND SECURE WITH DISCHARGE TUBE NUT AND LOCKING COLLAR:

- 13 INSTALL LID AND DISCHARGE TUBE NUT ONTO DISCHARGE TUBE.
- 14 SECURE LID ONTO PUMP CYLINDER BY ROTATING DISCHARGE TUBE NUT CLOCKWISE.
- 15 INSTALL PLUNGER INTO CYLINDER AND SECURE TO CYLINDER BY ROTATING LOCKING COLLAR CLOCKWISE.

## ASSEMBLE PLUNGER:

\* Apply Food Equipment Lubricant onto Seal and Seal O-Ring

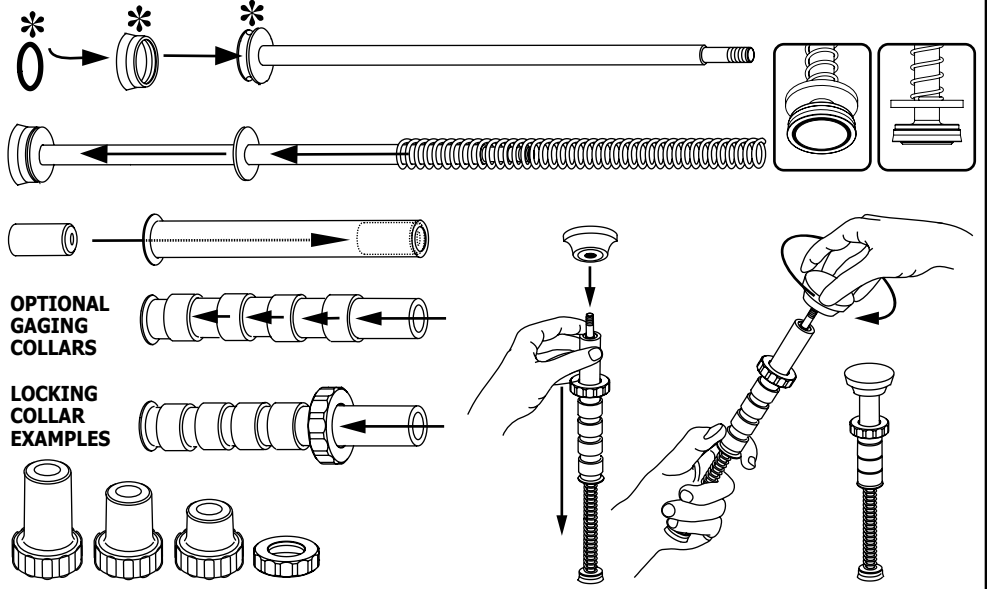

## INSTALL O-RINGS AND ASSEMBLE PUMP BASE:

\* Apply Food Equipment Lubricant onto all O-Rings

INSTALL SILICONE GASKET WITH FLAT SIDE FACING UP.

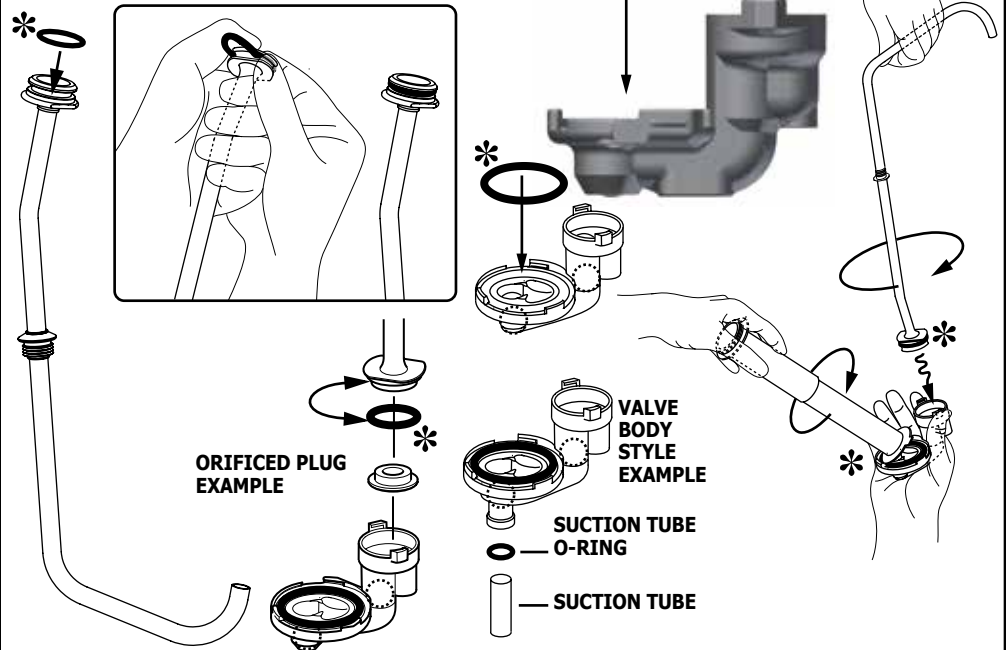

## INSTALL LID AND SECURE WITH DISCHARGE TUBE NUT AND LOCKING COLLAR:

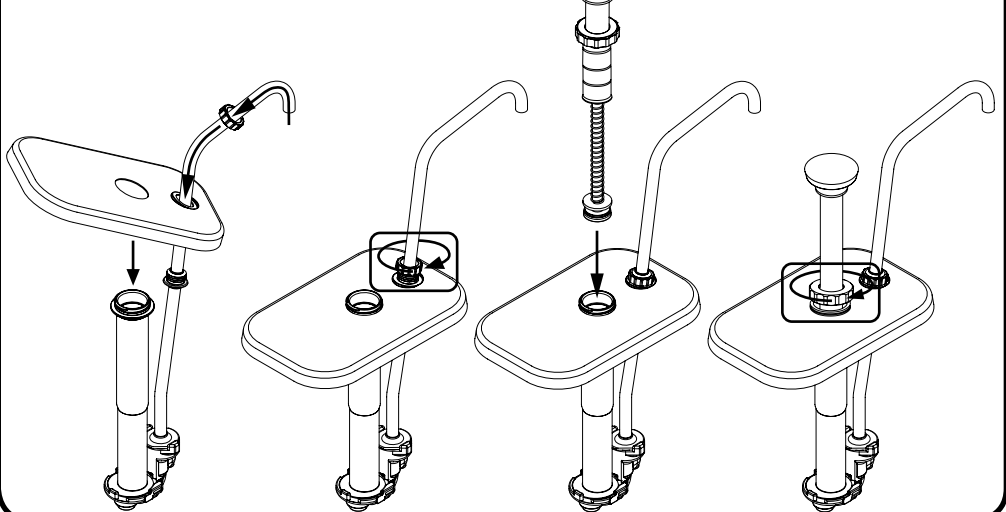

#### OPTIONAL ATTACHING PUMP TO PRODUCT POUCH:

- 1 SET PRODUCT POUCH FLAT ON COUNTERTOP WITH CONNECTOR CIRCLE FACING UP.
- 2 ALIGN PUMP, WITH PIERCING FITMENT VALVE BODY, DIRECTLY OVER PRODUCT POUCH CONNECTOR CIRCLE.
- 3 PRESS PUMP DOWN TO PIERCE DIRECTLY THROUGH FILM IN PRODUCT POUCH FITMENT CIRCLE.
  - PUMP WILL CONNECT AND "SNAP" SECURELY INTO PRODUCT POUCH.
- 4 INSTALL PUMP AND PRODUCT POUCH TOGETHER INTO UNIT OR FOUNTAIN JAR.
  - HOLD PUMP WITH PRODUCT POUCH WRAPPED UP AROUND BOTH SIDES OF PUMP TO INSTALL INTO UNIT OR JAR.

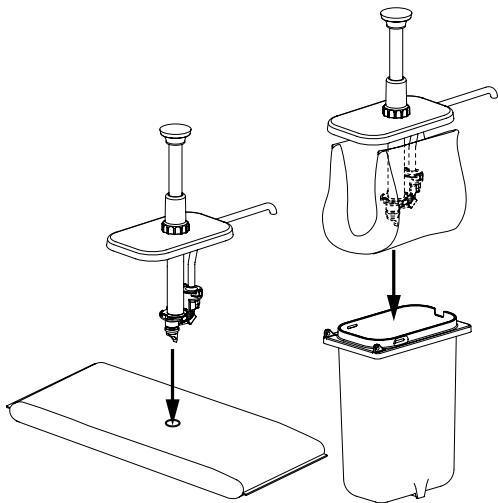

## GENERAL SERVICE, REPAIR, OR RETURNS

Before sending any item to Server Products for service, repair, or return, contact Server Products customer service to request a **Return Authorization Number**. Merchandise must be sent to Server Products with this number.

Merchandise being returned for credit must be in new and unused condition and not more than 90 days old and will be subject to a 20% (percent) restocking charge. Electrical parts (thermostats, heating elements etc.) are not returnable.

Server Products maintains a fully staffed service department with highly skilled factory trained personnel. Service is extremely prompt. Under normal circumstances, a repaired unit is shipped out the day after it is received. Labor charges are reasonable.

## SERVICE

Contact your dealer or Server Products Inc. customer service department for the following:

#### ORDERING REPLACEMENT PARTS

##### Be prepared to give this information:

- Model Letters/Name/Numbers
- Part Numbers- P/N
- Series Numbers/Letters
- Part Description

This information and other important data is stamped on the lid or cylinder of pumps or on the bottom or back side of every unit.

## SERVER PRODUCTS LIMITED WARRANTY

All Server Products equipment is backed by a two-year limited warranty against defects in materials and workmanship. For complete warranty information go to: [www.server-products.com](http://www.server-products.com)

#### SCOPE OF WARRANTY:

Server Products Inc. ("Server Products") warrants that, for a period of two (2) years from the date of purchase (the "Warranty Period"), the equipment manufactured by it will be free from defects in workmanship and materials provided the equipment is used in the manner and in the environment for which they were manufactured.

#### DISCLAIMERS AND LIMITATIONS:

Other than as set forth above, Server Products specifically disclaims all express and implied warranties, including but not limited to, warranties of merchantability and/or fitness for a particular purpose or use.

This warranty does not extend to repairs or alterations undertaken without the prior written consent of Server Products or for goods that are misused, abused or neglected or if the goods are not properly stored, maintained, installed or operated.

Server Products shall not be liable for incidental, special, indirect, exemplary, punitive or consequential damages resulting from the use of the good or arising out of any breach of this warranty; including but not limited to damage to property or loss of profits or revenue.

#### CLAIMS ADMINISTRATION:

All warranty claims must be made by calling our customer service department for a return authorization during the Warranty Period and any alleged defective unit must be returned to Server Products factory, freight prepaid.

Upon receipt of any defective unit, Server Products, at its option, may either: (i) replace any equipment proved to be defective, (ii) remedy or repair such defect or (iii) refund the purchase price of the defective equipment in the form of a credit applicable to future purchases. Server Products obligation and Buyer's sole remedy will be limited to these options. In the case of units or parts purchased by Server Products from a third-party supplier: Server Products' obligation and Buyer's sole remedy against Server Products or Server Products's suppliers shall not exceed the settlement which Server Products is able to obtain from its supplier.

## SAFETY GUIDELINES:

According to food and safety regulations, most foods must be stored and/or served at certain temperatures or they could become hazardous. Check with your local food and safety regulators for specific guidelines.

**Be aware of the product you are serving and the temperature the product is required to maintain. Server Products, Inc. can not be responsible for the serving of potentially hazardous product.**



NSF International lists this pump as: "Not acceptable for dispensing potentially hazardous foods."

Stainless steel is one of the best materials for food serving and storage, but there are many products which can corrode it. If you notice corrosion beginning on any stainless steel surface, you may need to change the cleansing agent, sanitizing agent, or the cleaning procedures you are using.

- Products containing: acids, alkalines, chlorine, or salt can corrode stainless steel.
- Sauerkraut and Au Jus sauces corrode stainless steel. Server Products, Inc. regrets that we can not honor warranty claims on stainless steel parts that have been affected by sauerkraut or Aus Jus.

## TROUBLESHOOTING

#### PROBLEMS WITH PUMP OPERATION AND/OR FLOW:

- **Clean pump.**

#### PUMP DISPENSES LITTLE OR NO PRODUCT.

- **Product may be too stiff or contain a solid that will not pass through pump.**

#### PORTION CONTROL IS NOT CONSISTENT.

- **Inspect gaging collar for any damage and/or proper installation.**

#### PUMP PLUNGER DOES NOT RETURN TO TOP OF STROKE AFTER DISPENSING PRODUCT.

- **Inspect spring for any damage; bent or broken. Replace spring if necessary.**

#### PUMP DRIPS.

- **Clean discharge tube with supplied cleaning brushes.**
- **Ensure product is not being heated by any external source(s) causing product to expand and drip from pump.**



**Server Products Inc.**  
3601 Pleasant Hill Road  
Richfield, WI 53076 USA



262.628.5600



800.558.8722



262.628.5110



[spsales@server-products.com](mailto:spsales@server-products.com)



[www.server-products.com](http://www.server-products.com)