



S E R V E R

SERVE BETTER™

Server Express™

Used with pouches
up to 1½ gallons.

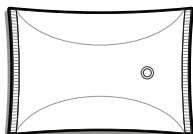

MODEL:
CE-PL

07397
BLACK SHROUD

07456
WHITE SHROUD

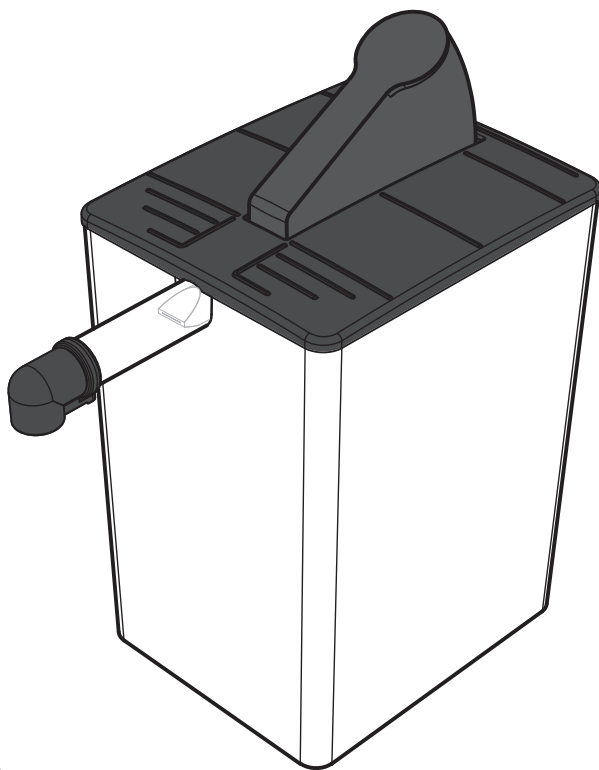

Thank You

...for purchasing our Server Express™ Pouched Condiment Dispenser. This portion controlled unit is sealed and sanitary, achieves excellent evacuation and has only a few parts for easy clean-up.

SIMPLIFY CONDIMENT MANAGEMENT — GO POUCHED

SAFETY



According to food and safety regulations, most foods must be stored and/or served at certain temperatures or they could become hazardous. Check with local food and safety regulators for specific guidelines. Server Products, Inc. cannot be responsible for the serving of potentially hazardous product.

IMPORTANT

Clean, rinse, sanitize, and dry parts daily or regularly to comply with local sanitization requirements.



NSF International lists this pump as:
"Not acceptable for dispensing potentially hazardous foods."

ADA
compliant

PARTS

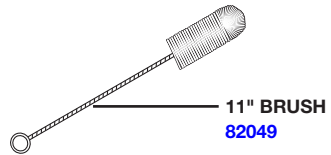
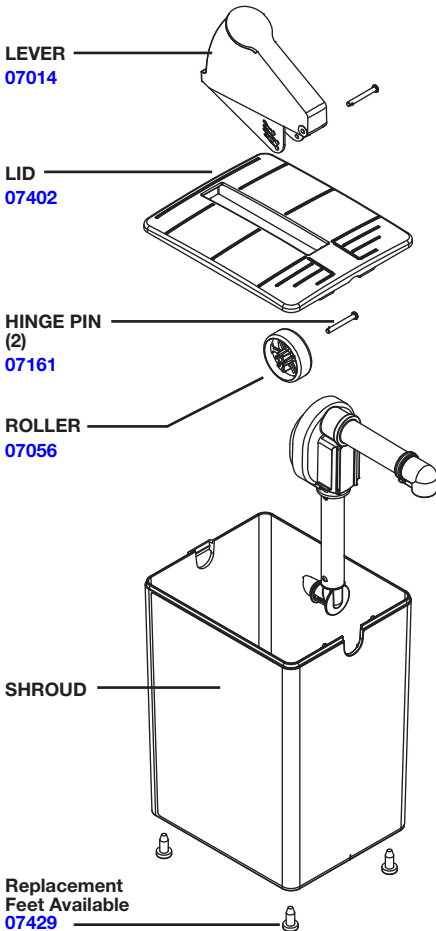

PUMP 07405

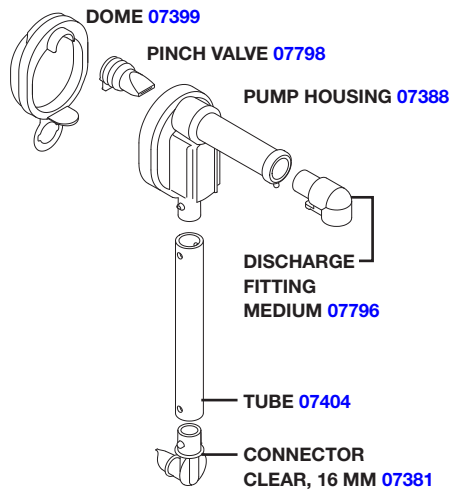

PUMP ASSEMBLY

WASH ALL PARTS
PROPERLY BEFORE USE. See page 7.

1 INSERT PINCH VALVE

into pump housing.

TIP: Squeeze the pinch valve open before installation to ensure it isn't stuck shut.

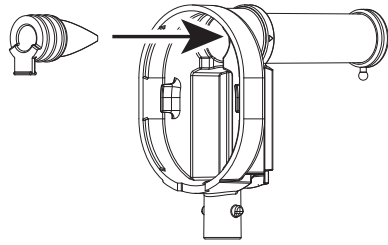

2 INSTALL DOME

Press dome into housing fully. Ensure valve flap covers bottom opening.

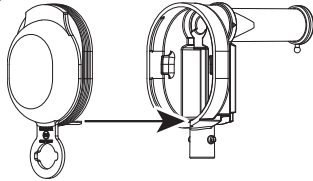

Wrap loop around lower opening to secure dome.

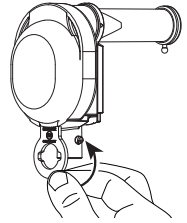

3 INSTALL TUBE

Lubricate with a small amount of clean water. Rotate and position until both pegs on housing fit into holes on tube.

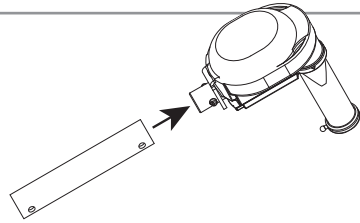

4 INSERT CONNECTOR

Lubricate with a small amount of clean water. Rotate and position until both pegs on connector fit into holes on tube. Connector must point away from end of discharge tube.

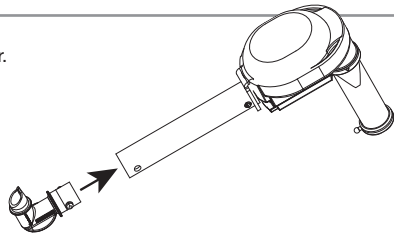

5 INSERT DISCHARGE FITTING

into pump housing discharge tube. Place loop of fitting around peg on end of discharge tube to secure.

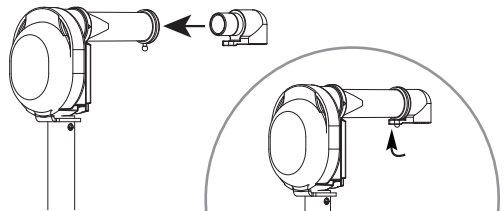

SETUP



PRACTICE SAFETY.
WASH ALL PARTS PROPERLY BEFORE USE. See page 7.

1 ATTACH POUCH TO PUMP

Firmly press piercing connector into center of pouch fitment.

An audible click indicates a secure connection.

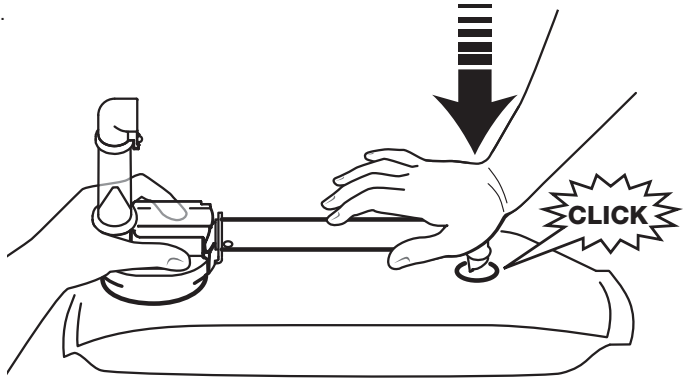

2 DROP IN

Slide pouch and pump into shroud.
Align pump guides into slots.

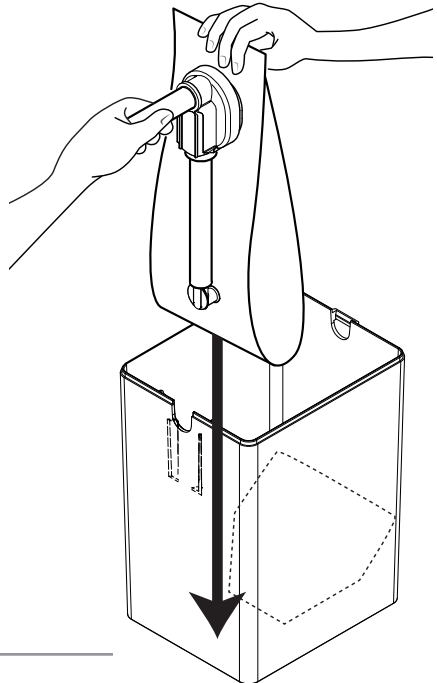

3 SNAP LID ON

Back tab of lid snaps into place.

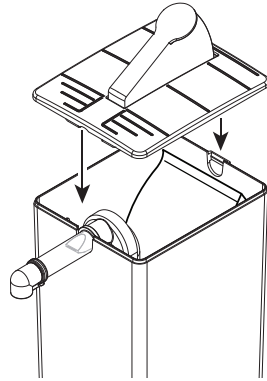

4 PRIME PUMP

Press lever several times until you see product in discharge tube.

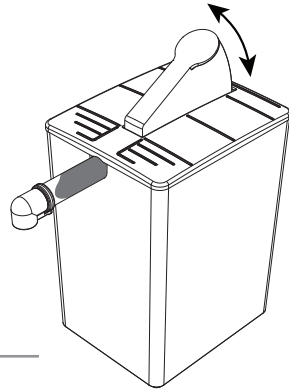

PORTION CONTROL

THE LID IS SET TO DELIVER 1 OZ PORTIONS.

If lid reassembly is needed:

One hinge pin attaches lever to lid.

Second hinge pin attaches roller to lever.
(Controls portion dispensed.)

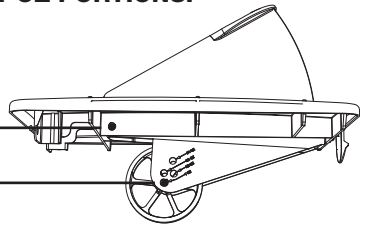

Install hinge pin through center roller hole and desired portion hole on lever.

Pin snaps into place.

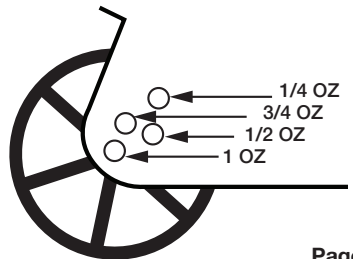
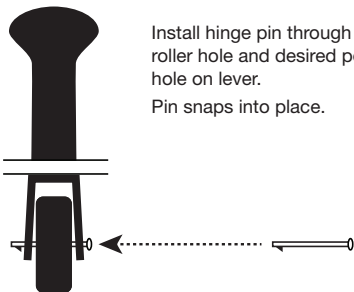

TAKEDOWN & DISASSEMBLY

1 REMOVE LID

Firmly press tab in back of lid to release.

2 REMOVE PUMP & POUCH

3 DETACH PUMP FROM POUCH

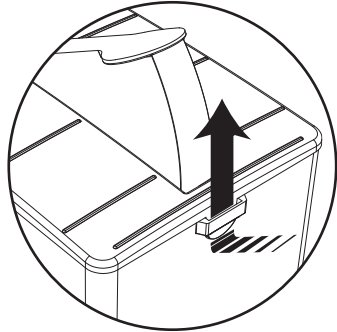

4 FLUSH & RINSE PUMP

Place lower end of pump into container of hot water. Pump until all remaining product is expelled and only water flows from discharge tube.

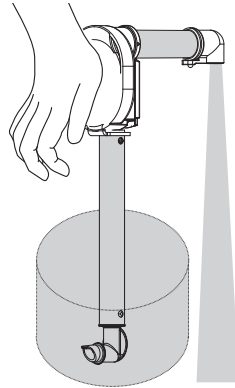

5 DISASSEMBLE

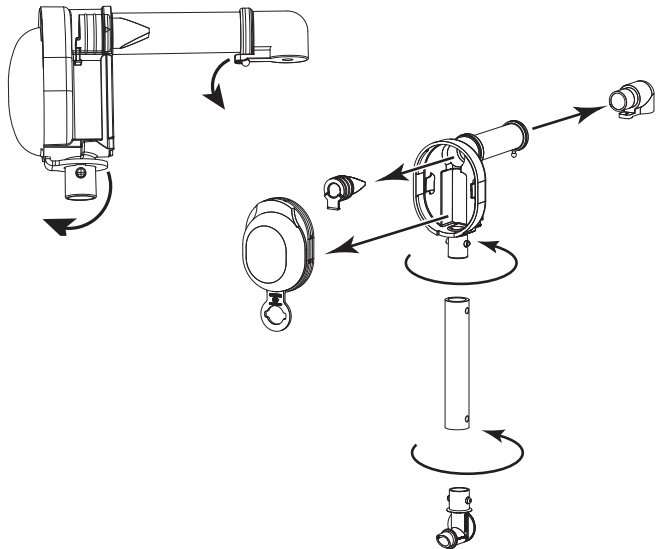

CLEANING

PUMP CLEANING

- 1 FLUSH & RINSE**
all pump surfaces with hot water. Place lower end of pump into container of hot water and operate pump until all remaining product is expelled and only hot water is discharged.
- 2 DISASSEMBLE & CLEAN**
all washable parts with soap and hot water. Use brush to clean any confined areas.
- 3 RINSE** fully with clear water.
- 4 SANITIZE**
all parts according to local sanitization requirements. All parts in contact with food must be sanitized.
- 5 AIR DRY** all parts fully.



YES!

Use dishwashing soap, hot water and nylon brush

Pump is dishwasher safe.

- Do not use abrasive, caustic or ammonia based cleansers.
- Do not use cleansing agents with high concentrations of acid, alkaline or chlorine.
- Do not use metal scrapers or cleaning pads that could scratch surfaces.

LID & SHROUD CLEANING

Lid & Shroud may be wiped clean with dishwashing soap & hot water.

Hand wash shroud.

DO NOT IMMERSE SHROUD IN WATER

- External surfaces may be wiped clean with a clean damp cloth.
- Glass and surface cleaners approved for use in food contact areas may be used.
- Do not use abrasive, caustic or ammonia based cleansers.
- Do not use metal scrapers or cleaning pads that could scratch surfaces.

SERVER PRODUCTS LIMITED WARRANTY

2
YEAR
WARRANTY



Server Products equipment is backed by a two-year limited warranty against defects in materials and workmanship.

For complete warranty information go to:

www.Server-Products.com

GENERAL SERVICE, REPAIR OR RETURNS

Before sending any item to Server Products for service, repair, or return, contact Server Products customer service to request a **Return Authorization Number**. Merchandise must be sent to Server Products with this number. Service is extremely prompt. Typically, units are repaired and ship out within 48 hours of receipt.

Merchandise being returned for credit must be in new and unused condition and not more than 90 days old and will be subject to a 20% restocking charge.

TROUBLESHOOTING

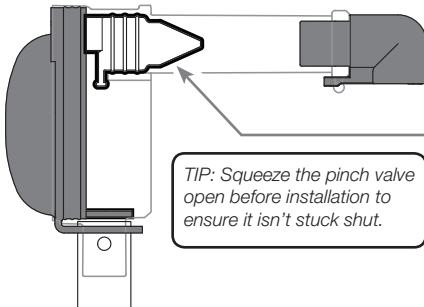

DIFFICULT TO ATTACH PUMP PARTS?

- Wet parts with clean water to help fit.

PRODUCT DOESN'T PUMP?

- Ensure pinch valve is inserted in housing.
- Ensure connector is snapped fully in place to fitment in pouch.
- Ensure pump is properly attached to pouch.
- Clean pump thoroughly.
- Ensure pump is properly installed into retaining slots inside front wall of shroud.

DOMES POPS OFF?

- Clean thoroughly. Food residue could prevent a tight seal between dome and housing.
- Ensure dome edges are flush with housing.

HELP or ORDERING REPLACEMENT PARTS

Server Products Inc.

3601 Pleasant Hill Road
Richfield, WI 53076 USA



262.628.5600 | 800.558.8722



SPSALES@SERVER-PRODUCTS.COM

Please be prepared with your **Series Number** and **Description** located on the back of unit base.

Individual **Part Numbers** listed on page 2.