

SERVER

• E S S E N T I A L S •

Eco Pump™

MODEL: BP-1

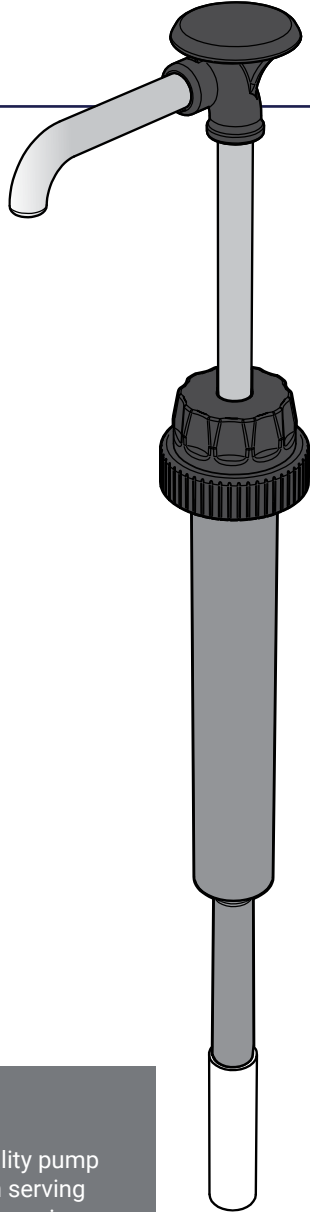

Thank You

for purchasing a Server Eco Pump™. This quality pump delivers precise portions so you can focus on serving craveable creations consistently without the ongoing expense of disposable pumps.

CONSISTENT PORTIONS—SERVE BETTER

BP-1 PUMP PARTS

HEAD ASSEMBLY

DISCHARGE TUBE

LOCKING COLLAR

STOP COLLAR (black)
88409

PISTON

SEAL
83005

PINCH VALVE
88202

PUMP DELIVERS
1 OZ PORTIONS

To reduce portion, add
GAGING COLLAR(S) (white)

88313 Small collar: 1/8 oz reduction
88204 Medium collar: 1/4 oz reduction
88205 Large collar: 1/2 oz reduction

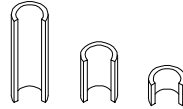

SPRING
88166

CYLINDER ASSEMBLY

CAP

CYLINDER

STAINLESS STEEL
BALL
1/2" DIAMETER
06022

(Ball snaps inside
cylinder and can
always remain installed,
even during cleaning.)

2.5" EXTENSION TUBE
88315

If needed: Add to bottom
of Cylinder Assembly
to extend length.

FOOD
EQUIPMENT
LUBRICANT
40179

11" BRUSH
82049

21" BRUSH
82526

SAFETY



According to food and safety regulations, most foods must be stored and/or served at certain temperatures or they could become hazardous. Check with local food and safety regulators for specific guidelines.

IMPORTANT

Clean, rinse, sanitize, and dry parts daily or regularly to comply with local sanitization requirements.

Be aware of the product you are serving and the temperature the product is required to maintain. Server Products, Inc. cannot be responsible for the serving of potentially hazardous product.



NSF International lists this pump as: "Not acceptable for dispensing potentially hazardous foods."

DISASSEMBLY

DISASSEMBLE AND WASH ALL PARTS PROPERLY BEFORE USE. See page 4.

During disassembly, collect small parts in a container to prevent loss.

1 REMOVE PUMP
from container of product.

2 SEPARATE CYLINDER ASSEMBLY & HEAD
Loosen locking collar to release.

3 REMOVE SPRING, CAP & EXTENSION TUBE FROM CYLINDER

4 REMOVE PINCH VALVE
from head assembly.

5 REMOVE SEAL
from head assembly by pressing it down and off with thumb. Do not use a sharp tool.

6 REMOVE STOP COLLAR & ANY GAGING COLLAR(S)
if necessary for cleaning.

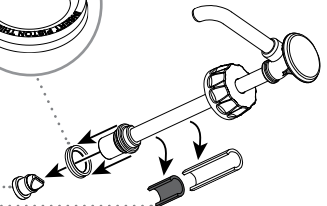
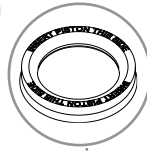
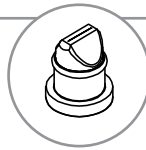
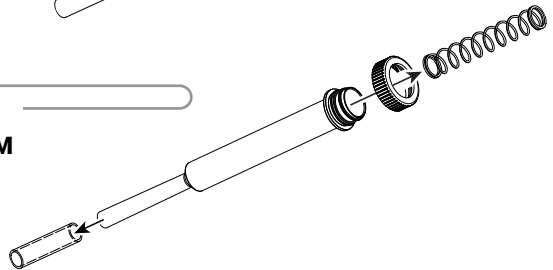
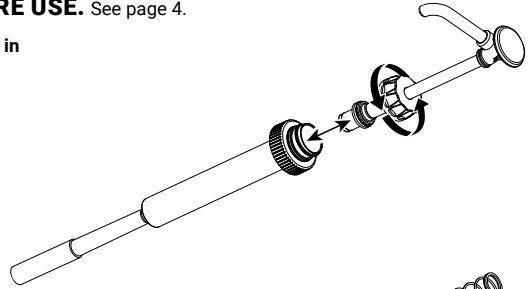

CLEANING



1 FLUSH & RINSE

all pump surfaces with hot water.
Place lower end of pump into container of hot water and operate pump until all remaining product is expelled and only hot water is discharged.

YES!

Use dishwashing soap, hot water and nylon brush

Pump is dishwasher safe.

2 DISASSEMBLE & CLEAN

all washable parts with soap and hot water
(See DISASSEMBLY on page 3.)

USE SUPPLIED BRUSH

to thoroughly clean inside discharge tube and any confined areas.

3 RINSE

fully with clear water.

4 SANITIZE

all parts according to local sanitization requirements. All parts in contact with food must be sanitized.

5 AIR DRY

all parts fully.

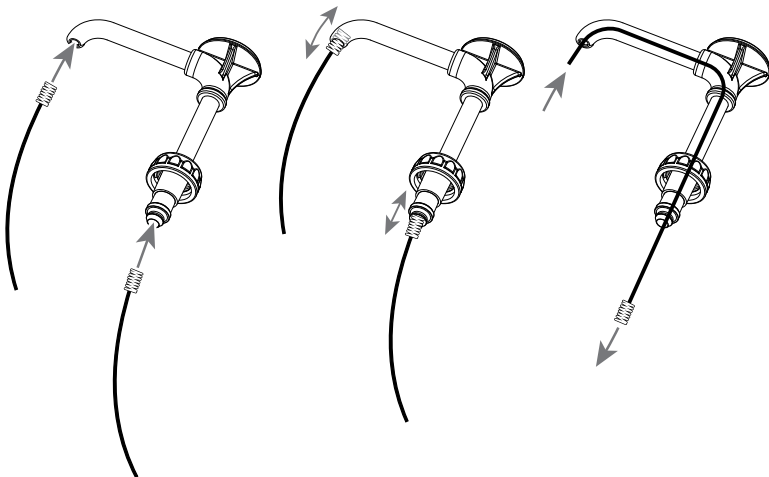

CLEAN-IN-PLACE PROCEDURE FOR PUMPS

1 CLEAN

- Pump out all (if any) remaining food product from inside pump body.
- Wash and rinse off outside of pump body.
- Flush out and rinse inside of pump.
- Place lower end of pump into container full of water and operate pump until all (if any) remaining product is expelled and only warm water flows from discharge tube.
- Mix 2 tsp (5 mL) of dishwashing detergent with 1 quart (.95 L) of hot tap water (approximately 110°F/43°C).
- Place lower end of pump into cleaning mixture. Pump until all cleaning mixture is expelled.

2 RINSE

- Place lower end of pump into 2 cups (.5 L) of hot tap water (approximately 110°F/43°C) and pump until all tap water is expelled.

3 SANITIZE

- Mix one 1 oz (30 mL) packet of KAY-5 Sanitizer/Cleaner (EPA REG No. 5389-15) with 2.5 gallons (9.5 L) of tap water (approximately room temperature).
- Place lower end of pump into this sanitizing mixture and repeatedly operate pump until 1 quart (.95 L) sanitizing mixture is pumped through pump.

4 RINSE

- Place lower end of pump into 1 cup (.24 L) of hot tap water (approximately 110°F/43°C) and pump until all tap water is expelled.

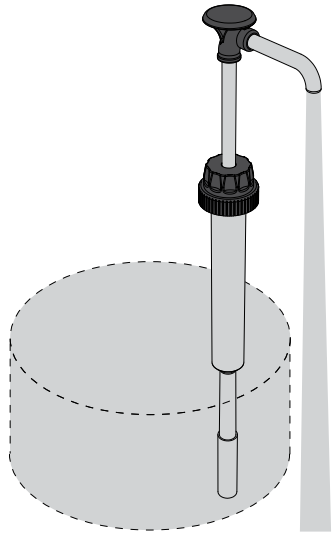

CARE OF STAINLESS STEEL

This durable pump includes stainless steel components.

If you notice corrosion beginning on any stainless steel surface, you may need to change the cleansing agent, sanitizing agent, or the cleaning procedures you are using.

- A mildly abrasive nylon or brass brush may be used to remove any stubborn deposits.

- Fully rinsing and drying all parts can help prevent corrosion. Elements and minerals in tap water can accumulate on stainless steel parts and create corrosion.
- Do not use abrasive, caustic or ammonia based cleansers.
- Do not use products containing acids, alkalines, chlorine, or salt. These agents can corrode stainless steel.
- Do not use metal scrapers or cleaning pads that could scratch surfaces.

ASSEMBLY



PRACTICE SAFETY. WASH ALL PARTS PROPERLY BEFORE USE. See page 4.

1 INSTALL SEAL

onto head assembly piston.
Apply small amount of food equipment lubricant inside seal.

TIP: Side of seal marked "INSERT PISTON THIS SIDE" must face top of head assembly. Flared end of seal must face down.

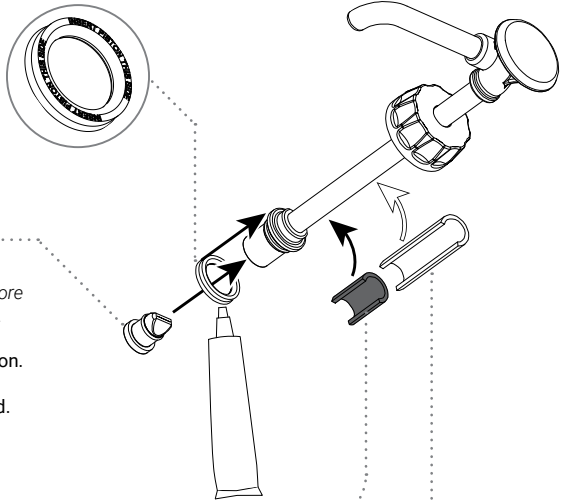

2 INSTALL PINCH VALVE

TIP: Squeeze the pinch valve open before installation to ensure it isn't stuck shut.

Install pinch valve into bottom of piston.

Press pinch valve securely to seal end.

3 INSTALL STOP COLLAR

onto side of head assembly piston.

OPTIONAL: ADD GAGING COLLAR(S)

to reduce portion size.
Small collar: 1/8 oz reduction
Medium collar: 1/4 oz reduction
Large collar: 1/2 oz reduction

4 INSERT SPRING INTO CYLINDER

OPTIONAL: ADD EXTENSION TUBE

to bottom of cylinder if extra length will be needed to reach product at bottom of container.

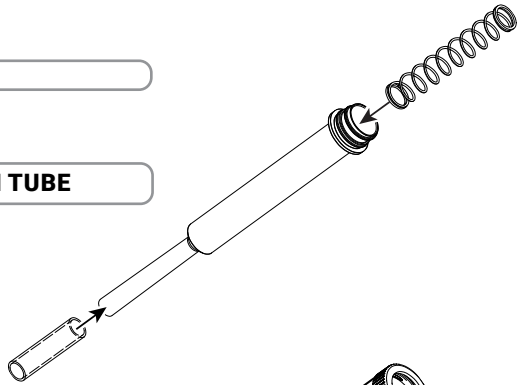

5 SNAP CAP ONTO CYLINDER

Press firmly to secure cap down over all threading on cylinder.

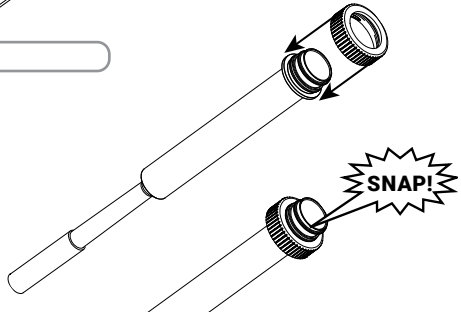

6**INSTALL HEAD ASSEMBLY INTO CYLINDER**

Apply a small amount of food equipment lubricant to the outside of seal.

Slide locking collar down onto cylinder threading.

Tighten firmly to secure head assembly to cylinder.

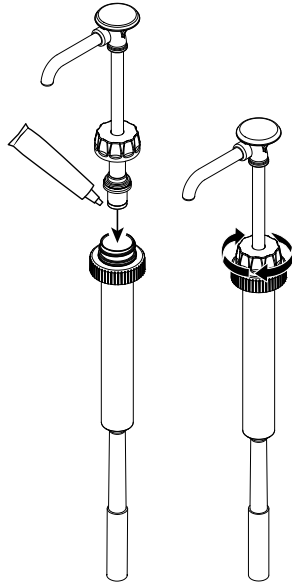
**7****INSERT & SECURE PUMP**

to product container.

Tighten cap very firmly onto product container threading.

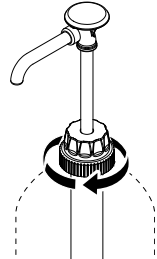
**8****PRIME PUMP**

Press pump several times until any air bubbles are eliminated and only product is dispensed.

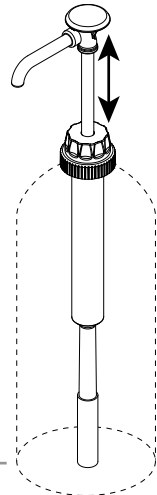

TROUBLESHOOTING

PRODUCT OOZES OUT FROM LOCKING COLLAR?

- Ensure that the **cap** is **securely snapped** into place below all the threading on the cylinder.

INCONSISTENT PORTIONS?

- **Clean pump.**
- Ensure product container is not empty and has **enough product** to pump.
- Ensure unit is **assembled correctly.**

TIP: Side of seal marked "INSERT PISTON THIS SIDE" must face top of head assembly. Flared end of seal must face down.

- Ensure **pinch valve** is installed correctly.

TIP: Squeeze the pinch valve open before installation to ensure it isn't stuck shut.

- Ensure that the **spring** is functional. Replace broken spring if necessary.

- Ensure that the **stainless steel ball** is snapped in place below tabs.

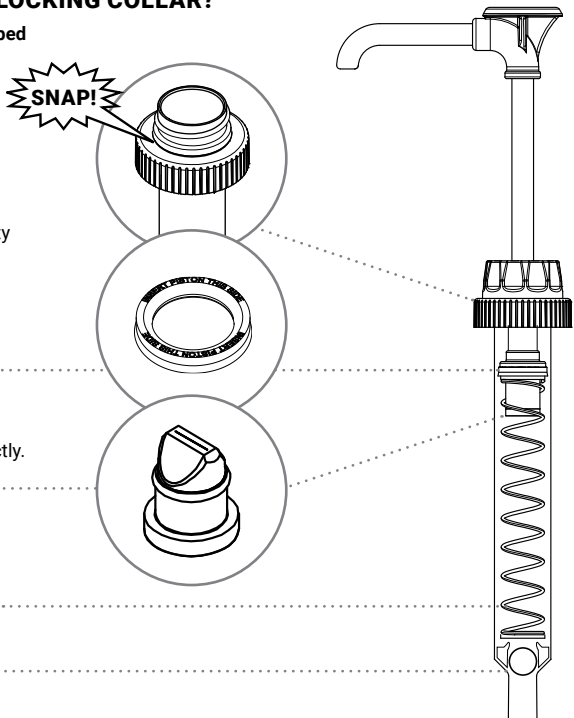

SERVER PRODUCTS LIMITED WARRANTY

2 YEAR
WARRANTY

This Server product is backed by a two-year limited warranty against defects in materials and workmanship. See Server-Products.com for details.

GENERAL SERVICE, REPAIR OR RETURNS

Before sending an item to Server Products, contact Customer Care to request a **Return Authorization Number**. The RA Number ensures proper processing and a prompt turnaround. Repaired units are typically shipped out within 48 hours of receipt.

Merchandise returned for credit will incur a 20% restocking charge, must be less than 90 days old, and in unused (new) condition. Electrical parts (thermostats, heating elements, etc.) are not returnable.

NEED HELP?

Server Products Inc.
3601 Pleasant Hill Road
Richfield, WI 53076 USA

Chat with us!
spsales@server-products.com
262.628.5600 | 800.558.8722

Please be prepared with your **Model, P/N** and **Series** located on the lid or base of the unit.

Example:

MODEL XXXX P/N #####		SERIES ##X ##X
-------------------------------	--	-------------------