



S E R V E R

SERVE BETTER™

Eco Dispenser™

UNIT MODEL: SPP
PUMP MODEL: BP-1

Used with pouches up to
64 oz with 16mm fitments.

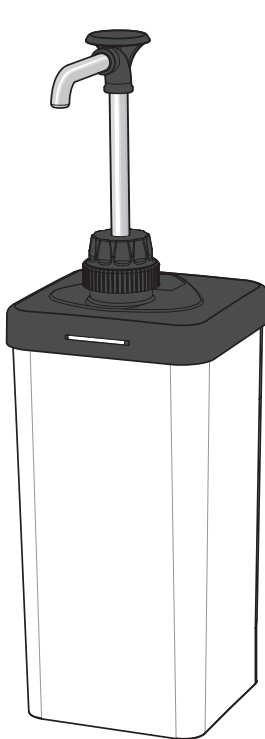

88680
USES PUMP
88548

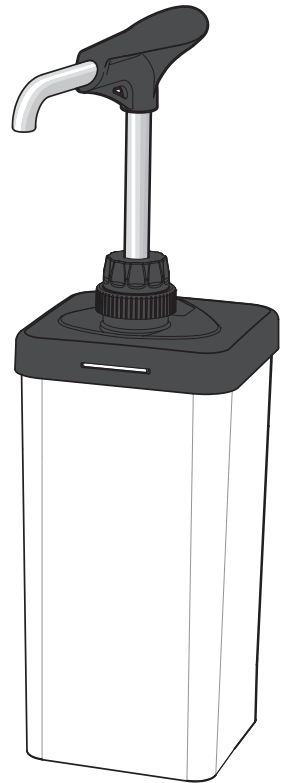

88876
USES PUMP
88877

Thank You

...for purchasing our Eco Dispenser™ to deliver high quality beverages. The reliable, reusable pump lasts for years while the environmentally friendly pouch system minimizes landfill impact.

CONSISTENT PORTIONS—SERVE BETTER

ECO DISPENSER™ PARTS

COMPLETE UNIT 88680 OR 88876

UNIT 88680
USE
PUMP 88548

UNIT 88876
USE
PUMP 88877

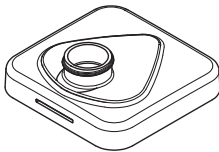
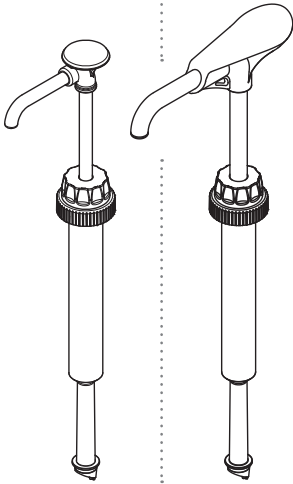

LID
88681

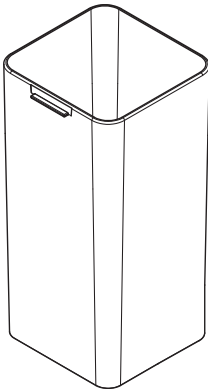

SHROUD
88682

PUMP 88548 OR 88877

PUMP DELIVERS 1 OZ PORTIONS

To reduce portion, add optional
GAGING COLLAR(S) onto side of head assembly

	PUMP 88548	PUMP 88877
Small collar: 1/8 oz reduction	88313	88887
Medium collar: 1/4 oz reduction	88204	88888
Large collar: 1/2 oz reduction	88205	88879

HEAD ASSEMBLY

PUMP 88548
USE
88545

PUMP 88877
USE
88718

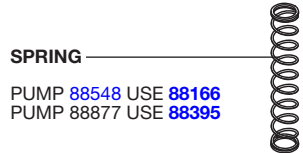
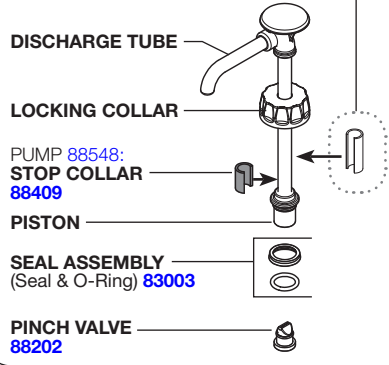

SPRING
PUMP 88548 USE 88166
PUMP 88877 USE 88395

CYLINDER ASSEMBLY

CAP
88016

CYLINDER
88553

STAINLESS STEEL BALL
1/2" DIAMETER
06022

(Ball snaps inside cylinder and can always remain installed, even during cleaning.)

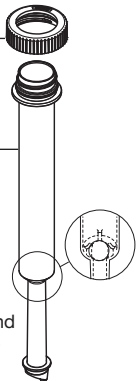

FOOD EQUIPMENT LUBRICANT 40179

11" BRUSH 82049

21" BRUSH
PUMP 88548 USE 88166
PUMP 88877 USE 84257

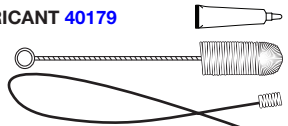

DISASSEMBLY

DISASSEMBLE AND WASH ALL PARTS PROPERLY BEFORE USE. See page 4.

During disassembly, collect small parts in a container to prevent loss.

1 REMOVE LID, PUMP & POUCH

from shroud.
Push up back tab of lid to release lid from pair of pegs.

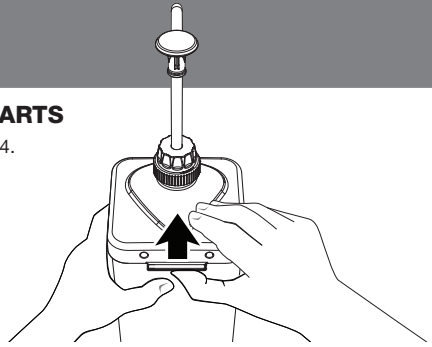

2 DETACH POUCH

from bottom of pump.

3 UNSCREW CAP FROM LID

to remove pump.

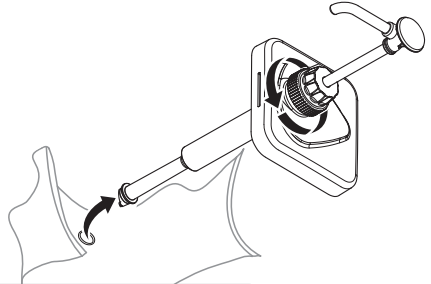

4 SEPARATE CYLINDER ASSEMBLY & HEAD

Loosen locking collar to release.

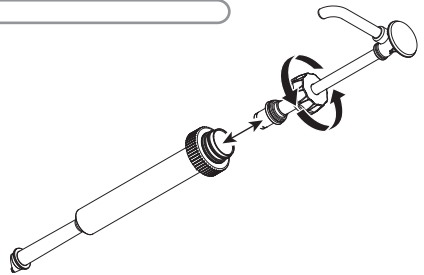

5 REMOVE SPRING & CAP FROM CYLINDER

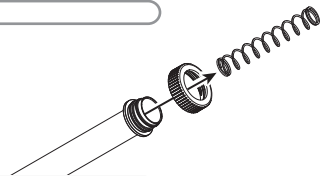

6 REMOVE PINCH VALVE

from head assembly.

7 REMOVE SEAL

from head assembly by pressing it down and off with thumb. Do not use a sharp tool.

8 REMOVE O-RING FROM SEAL

9 REMOVE STOP COLLAR & ANY GAGING COLLAR(S)

if necessary for cleaning.

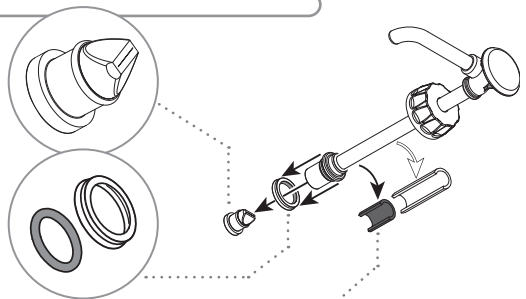

SAFETY



According to food and safety regulations, most foods must be stored and/or served at certain temperatures or they could become hazardous. Check with local food and safety regulators for specific guidelines.

Be aware of the product you are serving and the temperature the product is required to maintain. Server Products, Inc. cannot be responsible for the serving of potentially hazardous product.

IMPORTANT

Clean, rinse, sanitize, and dry parts daily or regularly to comply with local sanitization requirements.



NSF International lists this pump as: "Not acceptable for dispensing potentially hazardous foods."

CLEANING

PUMP CLEANING

1 FLUSH & RINSE

all pump surfaces with hot water.
Place lower end of pump into container of hot water and operate pump until all remaining product is expelled and only hot water is discharged.

2 DISASSEMBLE & CLEAN

all washable parts with soap and hot water
(See DISASSEMBLY on page 3.)

USE SUPPLIED BRUSH

to thoroughly clean inside discharge tube and any confined areas.

3 RINSE

fully with clear water.

4 SANITIZE

all parts according to local sanitization requirements. All parts in contact with food must be sanitized.

5 AIR DRY

all parts fully.

YES!

Use dishwashing soap, hot water and nylon brush



Pump is dishwasher safe.

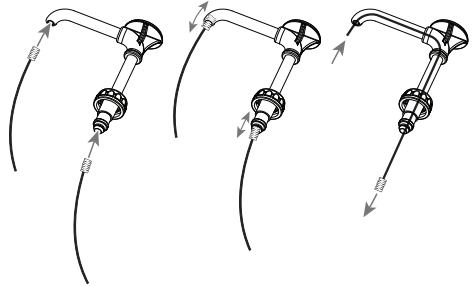

LID & SHROUD CLEANING

Lid & Shroud may be wiped clean with dishwashing soap & hot water.

CLEAN-IN-PLACE PROCEDURE FOR PUMPS

1 CLEAN

- Pump out all (if any) remaining food product from inside pump body.
- Wash and rinse off outside of pump body.
- Flush out and rinse inside of pump.
- Place lower end of pump into container full of water and operate pump until all (if any) remaining product is expelled and only warm water flows from discharge tube.
- Mix 1 tsp (5 mL) of dishwashing detergent with 1 quart (.95 L) of hot tap water (approximately 110°F/43°C).
- Place lower end of pump into cleaning mixture. Pump until all cleaning mixture is expelled.

2 RINSE

- Place lower end of pump into 2 cups (.5 L) of hot tap water (approximately 110°F/43°C) and pump until all tap water is expelled.

3 SANITIZE

- Mix one 1 oz (30 mL) packet of KAY-5 Sanitizer/Cleaner (EPA REG No. 5389-15) with 2.5 gallons (9.5 L) of tap water (approximately room temperature).
- Place lower end of pump into this sanitizing mixture and repeatedly operate pump until 1 quart (.95 L) sanitizing mixture is pumped through pump.

4 RINSE

- Place lower end of pump into 1 cup (.24 L) of hot tap water (approximately 110°F/43°C) and pump until all tap water is expelled.

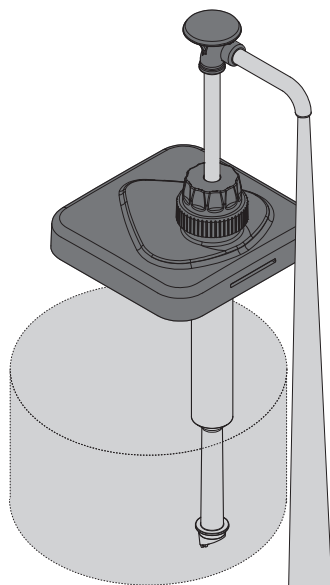

CARE OF STAINLESS STEEL

This durable pump includes stainless steel components.

If you notice corrosion beginning on any stainless steel surface, you may need to change the cleansing agent, sanitizing agent, or the cleaning procedures you are using.

- A mildly abrasive nylon or brass brush may be used to remove any stubborn deposits.

- Fully rinsing and drying all parts can help prevent corrosion. Elements and minerals in tap water can accumulate on stainless steel parts and create corrosion.
- Do not use abrasive, caustic or ammonia based cleansers.
- Do not use products containing acids, alkalines, chlorine, or salt. These agents can corrode stainless steel.
- Do not use metal scrapers or cleaning pads that could scratch surfaces.

ASSEMBLY



PRACTICE SAFETY. WASH ALL PARTS PROPERLY BEFORE USE. See page 4.

1 INSTALL O-RING

into seal.

Apply food equipment lubricant on O-ring

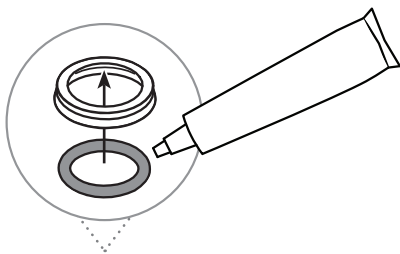

2 INSTALL SEAL

onto head assembly piston.

Apply small amount of food equipment lubricant inside seal.

TIP: Flared end of seal should face away from piston head.

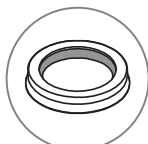

3 INSTALL PINCH VALVE

TIP: Squeeze the pinch valve open before installation to ensure it isn't stuck shut.

Install pinch valve into bottom of piston.
Press pinch valve securely to seal end.

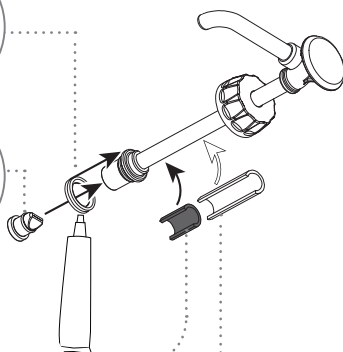

PUMP 88548:

INSTALL STOP COLLAR

onto side of head assembly piston.

4 OPTIONAL: ADD GAGING COLLAR(S)

to reduce portion size.

Small collar: 1/8 oz reduction

Medium collar: 1/4 oz reduction

Large collar: 1/2 oz reduction

5 INSERT SPRING INTO CYLINDER

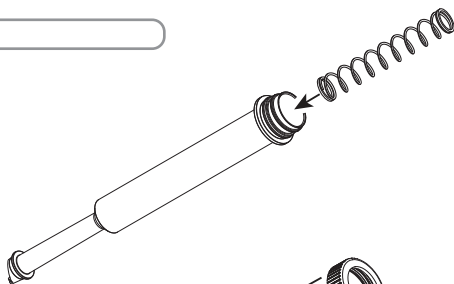

6 SNAP CAP ONTO CYLINDER

Press firmly to secure cap down over all threading on cylinder.

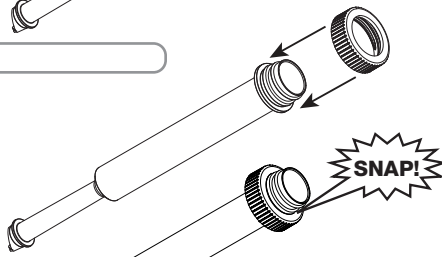

7 INSTALL HEAD ASSEMBLY INTO CYLINDER

Apply a small amount of food equipment lubricant to the outside of seal.

Slide locking collar down onto cylinder threading.

Tighten firmly to secure head assembly to cylinder.

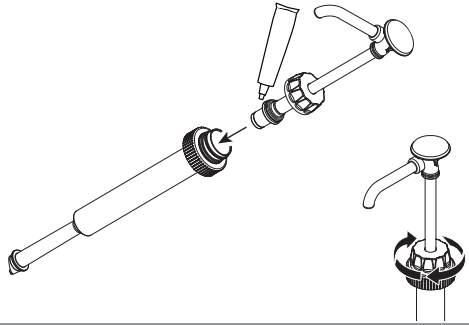

8 SECURE PUMP INTO LID

Tighten cap very firmly onto lid threading.

9 ATTACH PUMP TO POUCH

- Place pouch on countertop with pouch fitment circle facing upward.
- Position pump connector directly over center of pouch fitment.
- Press pump connector down to pierce through film in pouch fitment.

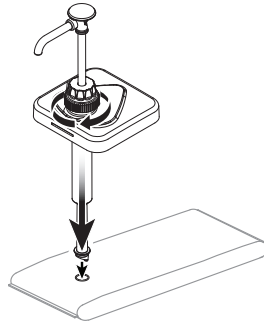

Pump connector is fully engaged when top surface of pouch fitment touches pump connector rim.

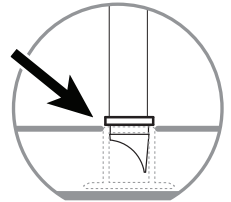

10 INSERT PUMP, LID & POUCH COMBINATION INTO BASE

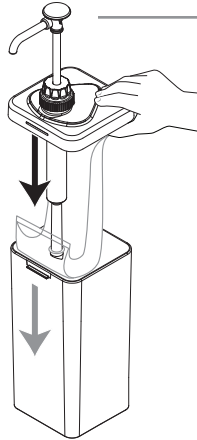

11 SECURE LID

Insert front slot of lid into tab on face of base.

Push lid down to snap onto back pegs on shroud.

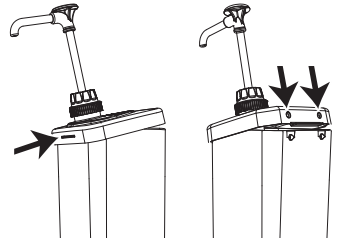

12 PRIME PUMP

Press pump several times until any air bubbles are eliminated and only product is dispensed.

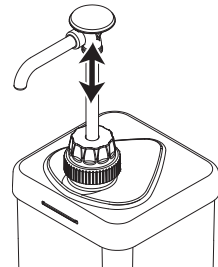

TROUBLESHOOTING

PRODUCT OZZES OUT FROM LOCKING COLLAR?

- Ensure that the **cap** is **securely snapped** into place past all threads on the cylinder.

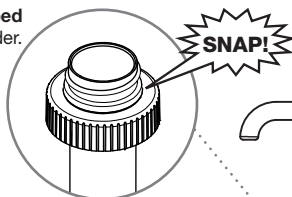

INCONSISTENT PORTIONS?

- **Clean pump.**
- Ensure product container is not empty and has **enough product** to pump.
- Ensure unit is **assembled correctly.**
TIP: Seal has a slight taper. Install with flat side towards top, flared side down.
- Ensure **pinch valve** is installed correctly.
TIP: Squeeze the pinch valve open before installation to ensure it isn't stuck shut.
- Ensure that the **spring** is functional. Replace broken spring if necessary.
- Ensure that the **stainless steel ball** is snapped in place below tabs.

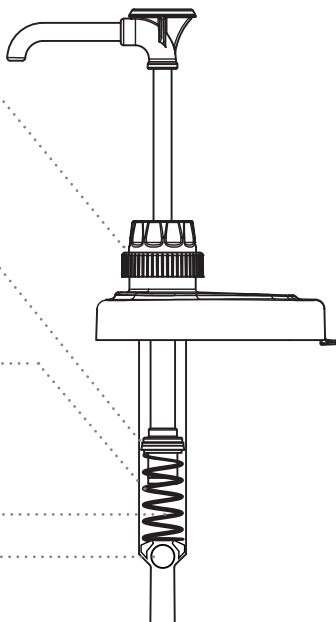
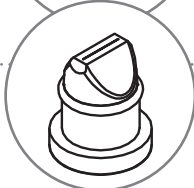
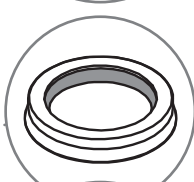

SERVER PRODUCTS LIMITED WARRANTY

2 YEAR
WARRANTY



Server Products equipment is backed by a two-year limited warranty against defects in materials and workmanship.

For complete warranty information go to:

www.Server-Products.com

GENERAL SERVICE, REPAIR OR RETURNS

Before sending any item to Server Products for service, repair, or return, contact Server Products customer service to request a **Return Authorization Number**. Merchandise must be sent to Server Products with this number. Service is extremely prompt. Typically, units are repaired and ship out within 48 hours of receipt.

Merchandise being returned for credit must be in new and unused condition and not more than 90 days old and will be subject to a 20% restocking charge.

NEED HELP?

Server Products Inc.

3601 Pleasant Hill Road
Richfield, WI 53076 USA



262.628.5600 | 800.558.8722



SPSALES@SERVER-PRODUCTS.COM

Please be prepared with your **Series Number** and **Description** located on the back of the unit.

Please refer to page 2 for individual **Part Numbers**.