



S E R V E R

SERVE BETTER™



Bottle Pump

MODEL: BP-1
88477

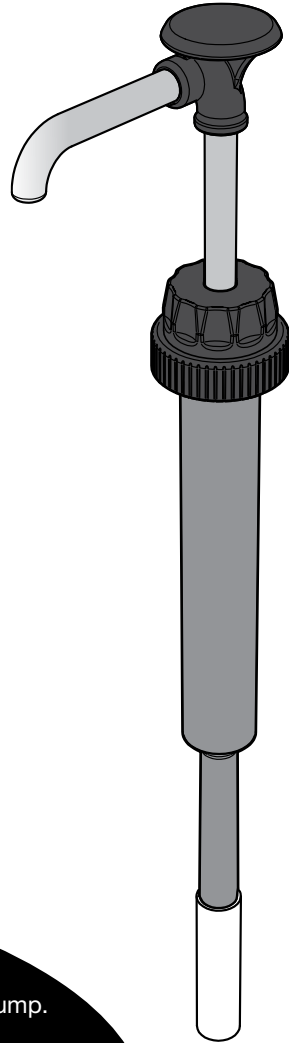

Thank You

...for purchasing our Stainless Steel Hybrid Pump. This quality, NSF listed pump delivers precise portions and is a reliable alternative to the constant expense of disposable pumps.

CONSISTENT PORTIONS—SERVE BETTER

88477 BP-1 PUMP PARTS

HEAD ASSEMBLY 88478

DISCHARGE TUBE

LOCKING COLLAR

PISTON

SEAL
83005

PINCH VALVE
88202

GAGING COLLAR
88411

Add to set portion size to 1/2 oz.
(Without collar, portion is 1 oz.)

Keep second gaging collar as a spare part.

SPRING
88166

CYLINDER ASSEMBLY 88496

CAP
88016

CYLINDER
88247

STAINLESS STEEL BALL
1/2" DIAMETER
06022

(Ball snaps inside cylinder and can always remain installed, even during cleaning.)

FOOD EQUIPMENT LUBRICANT
40179

11" BRUSH
82049

21" BRUSH
82526

2.5" EXTENSION TUBE
88315

If needed: Add to bottom of Cylinder Assembly to extend length.

SAFETY



According to food and safety regulations, most foods must be stored and/or served at certain temperatures or they could become hazardous. Check with local food and safety regulators for specific guidelines.

IMPORTANT

Clean, rinse, sanitize, and dry parts daily or regularly to comply with local sanitization requirements.

Be aware of the product you are serving and the temperature the product is required to maintain. Server Products, Inc. cannot be responsible for the serving of potentially hazardous product.



NSF International lists this pump as: "Not acceptable for dispensing potentially hazardous foods."

DISASSEMBLY

DISASSEMBLE AND WASH

ALL PARTS PROPERLY BEFORE USE. See page 4.

During disassembly, collect small parts in a container to prevent loss.

1 REMOVE PUMP
from container of product.

2 SEPARATE CYLINDER ASSEMBLY & HEAD
Loosen locking collar to release.

3 REMOVE SPRING, CAP & EXTENSION TUBE FROM CYLINDER

4 REMOVE PINCH VALVE
from head assembly.

5 REMOVE SEAL
from head assembly by pressing it down and off with thumb. Do not use a sharp tool.

6 REMOVE GAGING COLLAR
if necessary for cleaning.

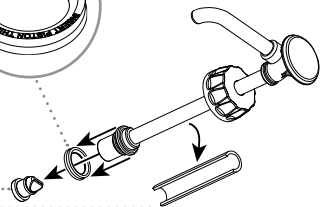
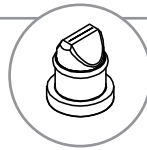
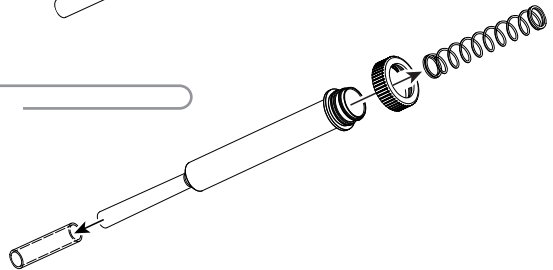
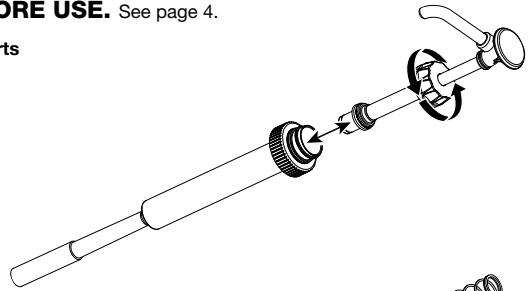

CLEANING



1 FLUSH & RINSE

all pump surfaces with hot water.
Place lower end of pump into container of hot water and operate pump until all remaining product is expelled and only hot water is discharged.

YES!

Use dishwashing soap, hot water and nylon brush

Pump is dishwasher safe.

2 DISASSEMBLE & CLEAN

all washable parts with soap and hot water
(See DISASSEMBLY on page 3.)

USE SUPPLIED BRUSH

to thoroughly clean inside discharge tube and any confined areas.

3 RINSE

fully with clear water.

4 SANITIZE

all parts according to local sanitization requirements. All parts in contact with food must be sanitized.

5 AIR DRY

all parts fully.

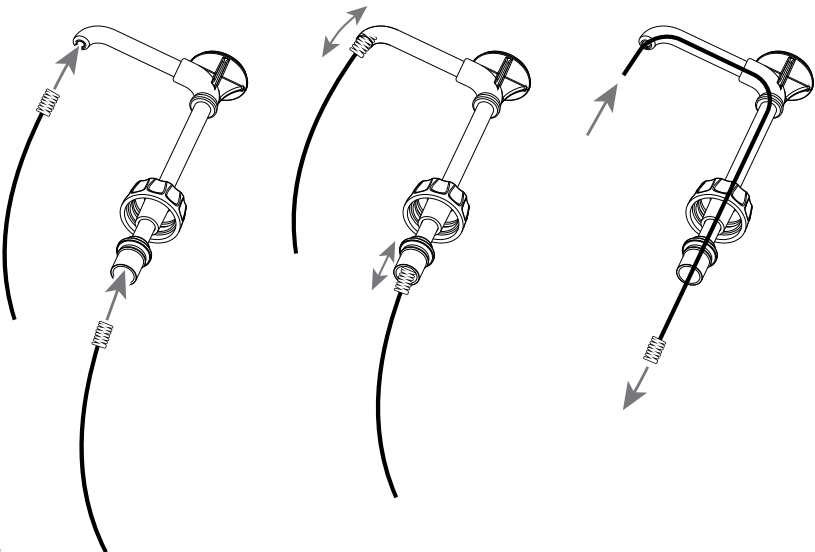

CLEAN-IN-PLACE PROCEDURE FOR PUMPS

1 CLEAN

- Pump out all (if any) remaining food product from inside pump body.
- Wash and rinse off outside of pump body.
- Flush out and rinse inside of pump.
- Place lower end of pump into container full of water and operate pump until all (if any) remaining product is expelled and only warm water flows from discharge tube.
- Mix 2 tsp (5 mL) of dishwashing detergent with 1 quart (.95 L) of hot tap water (approximately 110°F/43°C).
- Place lower end of pump into cleaning mixture. Pump until all cleaning mixture is expelled.

2 RINSE

- Place lower end of pump into 2 cups (.5 L) of hot tap water (approximately 110°F/43°C) and pump until all tap water is expelled.

3 SANITIZE

- Mix one 1 oz (30 mL) packet of KAY-5 Sanitizer/Cleaner (EPA REG No. 5389-15) with 2.5 gallons (9.5 L) of tap water (approximately room temperature).
- Place lower end of pump into this sanitizing mixture and repeatedly operate pump until 1 quart (.95 L) sanitizing mixture is pumped through pump.

4 RINSE

- Place lower end of pump into 1 cup (.24 L) of hot tap water (approximately 110°F/43°C) and pump until all tap water is expelled.

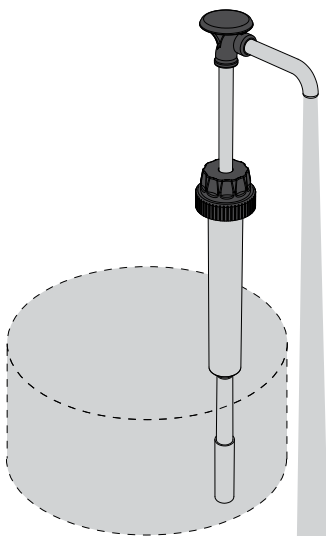

CARE OF STAINLESS STEEL

This durable pump includes stainless steel components.

If you notice corrosion beginning on any stainless steel surface, you may need to change the cleansing agent, sanitizing agent, or the cleaning procedures you are using.

- A mildly abrasive nylon or brass brush may be used to remove any stubborn deposits.

- Fully rinsing and drying all parts can help prevent corrosion. Elements and minerals in tap water can accumulate on stainless steel parts and create corrosion.
- Do not use abrasive, caustic or ammonia based cleansers.
- Do not use products containing acids, alkalines, chlorine, or salt. These agents can corrode stainless steel.
- Do not use metal scrapers or cleaning pads that could scratch surfaces.

ASSEMBLY



PRACTICE SAFETY. WASH ALL PARTS PROPERLY BEFORE USE. See page 4.

1 INSTALL SEAL

onto head assembly piston.
Apply small amount of food equipment lubricant inside seal.

TIP: Side of seal marked "INSERT PISTON THIS SIDE" must face top of head assembly. Flared end of seal must face down.

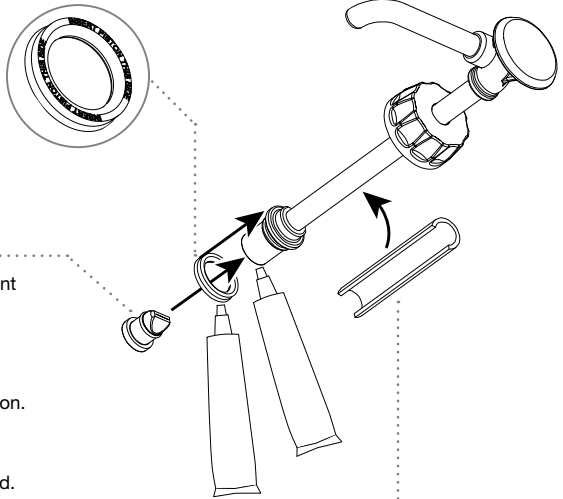

2 INSTALL PINCH VALVE

Apply small amount of food equipment lubricant inside bottom of piston.

TIP: Squeeze the pinch valve open before installation to ensure it isn't stuck shut.

Install pinch valve into bottom of piston.

Rotate pinch valve to spread lubricant evenly.

Press pinch valve securely to seal end.

3 INSTALL GAGING COLLAR

onto side of head assembly piston

This sets portion dispensed to 1/2 oz.

4 INSERT SPRING INTO CYLINDER

OPTIONAL: ADD EXTENSION TUBE

to bottom of cylinder if extra length will be needed to reach product at bottom of container.

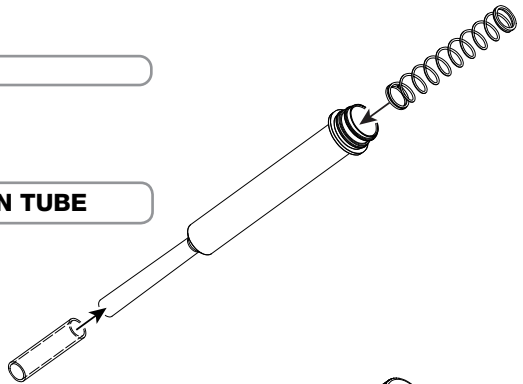

5 SNAP CAP ONTO CYLINDER

Press firmly to secure cap down over all threading on cylinder.

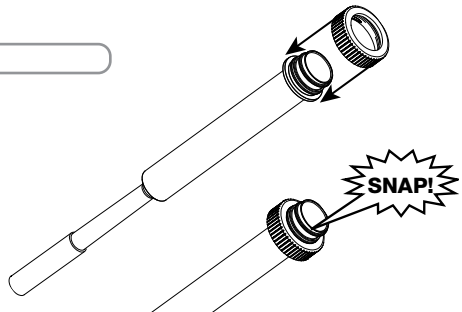

6**INSTALL HEAD ASSEMBLY INTO CYLINDER**

Apply a small amount of food equipment lubricant to the outside of seal.

Slide locking collar down onto cylinder threading.

Tighten firmly to secure head assembly to cylinder.

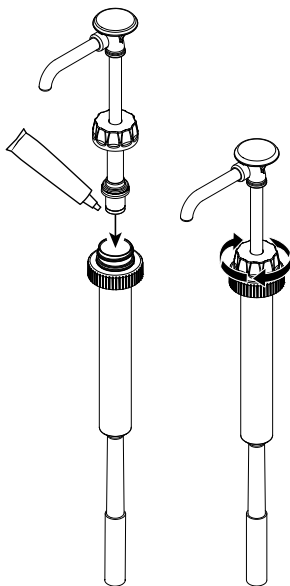
**7****INSERT & SECURE PUMP**

to product container.

Tighten cap very firmly onto product container threading.

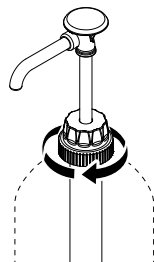
**8****PRIME PUMP**

Press pump several times until any air bubbles are eliminated and only product is dispensed.

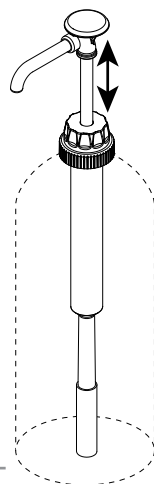

TROUBLESHOOTING

PRODUCT OZZES OUT FROM LOCKING COLLAR?

- Ensure that the **cap is securely snapped** into place below all the threading on the cylinder.

INCONSISTENT PORTIONS?

- **Clean pump.**
- Ensure product container is not empty and has **enough product** to pump.
- Ensure **gaging collar** is installed on side of head assembly piston.

- Ensure unit is **assembled correctly.**

TIP: Side of seal marked "INSERT PISTON THIS SIDE" must face top of head assembly. Flared end of seal must face down.

- Ensure **pinch valve** is installed correctly.

TIP: Squeeze the pinch valve open before installation to ensure it isn't stuck shut.

- Ensure that the **spring** is functional. Replace broken spring if necessary.

- Ensure that the **stainless steel ball** is snapped in place below tabs.

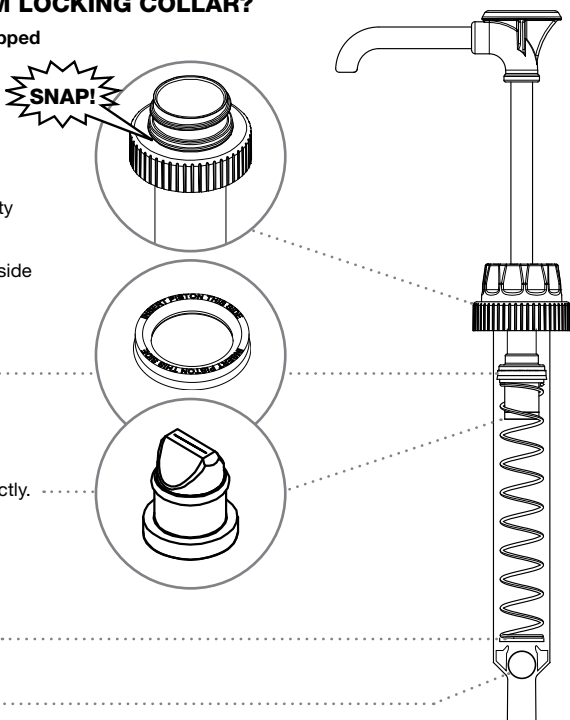

SERVER PRODUCTS LIMITED WARRANTY

2 YEAR
WARRANTY



Server Products equipment is backed by a two-year limited warranty against defects in materials and workmanship.

For complete warranty information go to:

www.Server-Products.com

GENERAL SERVICE, REPAIR OR RETURNS

Before sending any item to Server Products for service, repair, or return, contact Server Products customer service to request a **Return Authorization Number**. Merchandise must be sent to Server Products with this number. Service is extremely prompt. Typically, units are repaired and ship out within 48 hours of receipt.

Merchandise being returned for credit must be in new and unused condition and not more than 90 days old and will be subject to a 20% restocking charge.

HELP or ORDERING REPLACEMENT PARTS

Server Products Inc.

3601 Pleasant Hill Road
Richfield, WI 53076 USA



262.628.5600 | 800.558.8722



SPSALES@SERVER-PRODUCTS.COM

Please refer to page 2 for descriptions of pump components.

Examine your pump parts. Certain components, such as the cylinder cap, may be marked with individual part numbers.