



S E R V E R

SERVE BETTER™



Maximo Sauce Dispensing Unit

UNIT
MODEL:
SPPG

PUMP
MODEL:
BP-1



Chocolate Maximo Unit

0.33 fl oz portions

71195 Server 87974

0.50 fl oz portions

71197 Server 87975

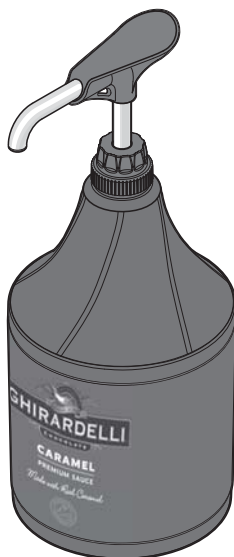

Caramel Maximo Unit

0.33 fl oz portions

71196 Server 87977

0.625 fl oz portions

71198 Server 87976

Thank You

...for purchasing your Maximo Sauce Dispensing Unit. This efficient, environmentally-friendly system delivers precise portions and is a reliable alternative to the constant expense of disposable pumps.

CONSISTENT PORTIONS—SERVE BETTER

*Ghirardelli Maximo
Sauce Dispensing
System Video
Directions:*



SAFETY



According to food and safety regulations, most foods must be stored and/or served at certain temperatures or they could become hazardous. Check with local food and safety regulators for specific guidelines.

Be aware of the product you are serving and the temperature the product is required to maintain. Server Products, Inc. cannot be responsible for the serving of potentially hazardous product.

IMPORTANT

Clean, rinse, sanitize, and dry parts daily or regularly to comply with local sanitization requirements.



NSF International lists this pump as: "Not acceptable for dispensing potentially hazardous foods."

SYSTEM PARTS

Pumps are preset to deliver correct portions:

0.33 FL OZ PUMP
87986

0.50 FL OZ PUMP
87982

0.625 FL OZ PUMP
87991

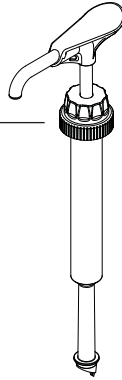

CHOCOLATE LID
88352

CARAMEL LID
88367

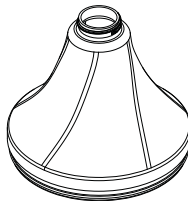
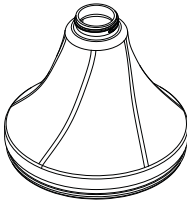

CHOCOLATE BASE
88376

CARAMEL BASE
88377

FOOD EQUIPMENT LUBRICANT
40179

11" BRUSH
82049

21" BRUSH
84257

SCRAPER
87022

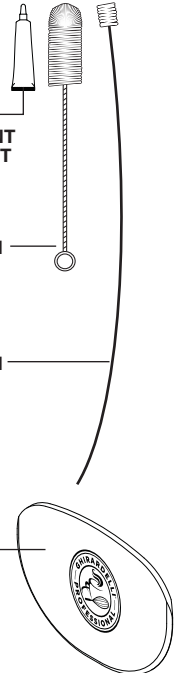

PUMP DETAILS FOR 87986, 87982, 87991

HEAD ASSEMBLY

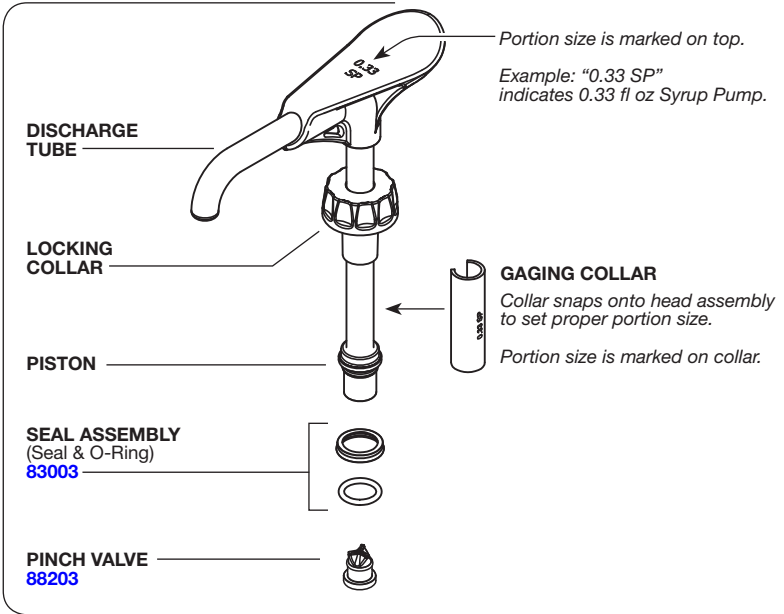

SPRING
88395



CYLINDER ASSEMBLY

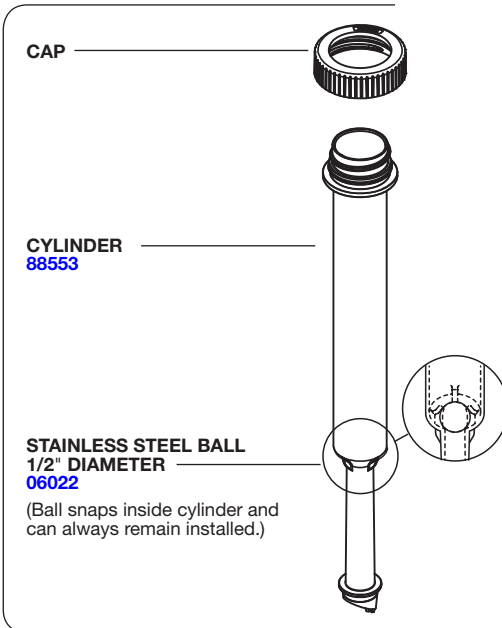

ASSEMBLY



PRACTICE SAFETY. WASH ALL PARTS PROPERLY BEFORE USE. See page 10.

1 INSTALL O-RING

into seal.

Apply food equipment lubricant on O-ring

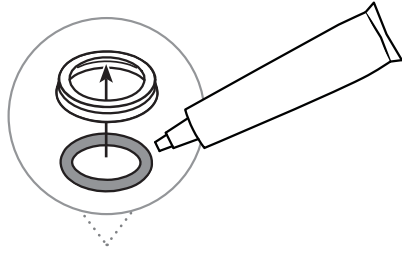

2 INSTALL SEAL

onto head assembly piston.

Apply small amount of food equipment lubricant inside seal.

TIP: Flared end of seal should face away from piston head.

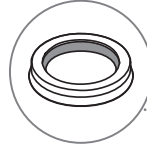

3 INSTALL PINCH VALVE

Apply small amount of food equipment lubricant inside bottom of piston.

TIP: Squeeze the pinch valve open before installation to ensure it isn't stuck shut.

Install pinch valve into bottom of piston.

Rotate pinch valve to spread lubricant evenly.

Press pinch valve securely to seal end.

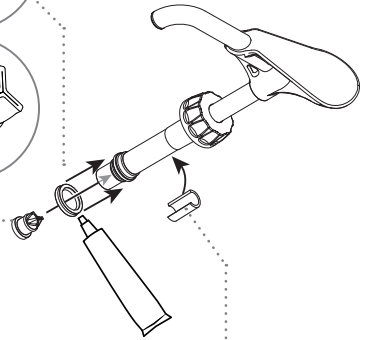
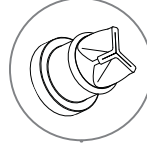

4 INSTALL GAGING COLLAR

onto side of head assembly piston.

Portion size marked on gaging collar must match portion size marked on top of pump.

5 INSERT SPRING INTO CYLINDER

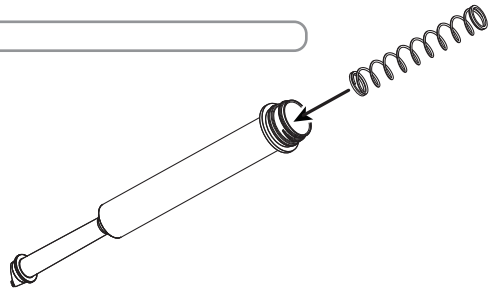

6 SNAP CAP ONTO CYLINDER

Press firmly to secure cap down over all threading on cylinder.

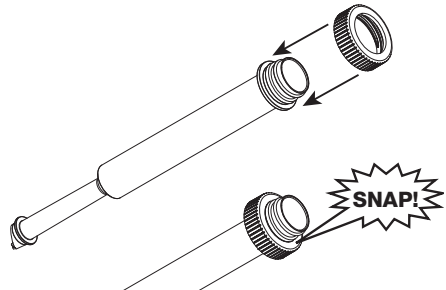

7**INSTALL HEAD ASSEMBLY
INTO CYLINDER**

Apply a small amount of food equipment
lubricant to the outside of seal.

Slide locking collar down onto
cylinder threading.

Tighten firmly to secure head assembly
to cylinder.

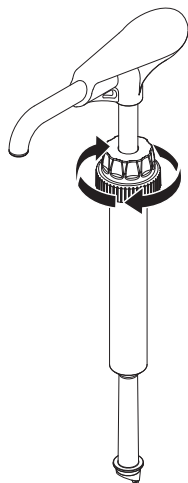
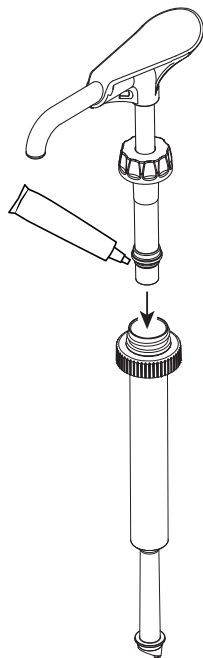

ASSEMBLY

Continued from pages 4 & 5.

8

ATTACH PUMP TO LID

Screw pump cap onto lid threading to secure.

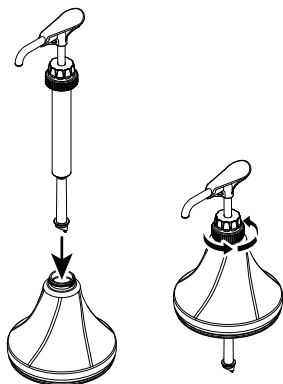

9

ATTACH PUMP TO POUCH

- Place sauce pouch on countertop with pouch fitment circle facing upward.
- Position pump connector directly over center of pouch fitment.
- Press pump connector down to pierce through film in pouch fitment.
- Pump connector is fully engaged when top surface of pouch fitment touches pump connector rim.

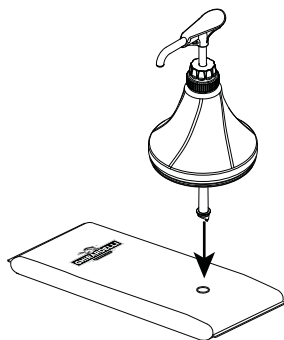

10

INSERT PUMP, LID & POUCH COMBINATION INTO BASE

Loosely fold pouch around bottom of pump while inserting into base.

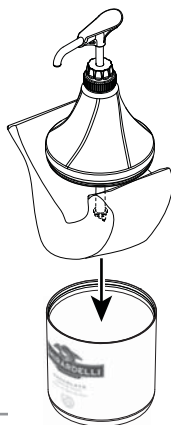

- 11 PUSH LID DOWN**
onto base.
Snap into position to secure.



- 12 PRIME PUMP**
Press pump several times until sauce
is dispensed.



MAXIMIZE POUCH EVACUATION

**WHEN SAUCE POUCH SEEMS EMPTY
(AFTER PUMPING), USE POUCH SCRAPER.**

- 1 REMOVE PUMP, LID & POUCH COMBINATION FROM BASE**
- 2 STRETCH POUCH FLAT**
on countertop.
- 3 USE SCRAPER**
to push sauce towards pump and
maximize evacuation from pouch.
- 4 RETURN PUMP, LID & POUCH FOR OPERATION**
- 5 DISPENSE UNTIL ALL REMAINING SAUCE IS EVACUATED FROM POUCH**
Completely empty pouch may
be discarded.

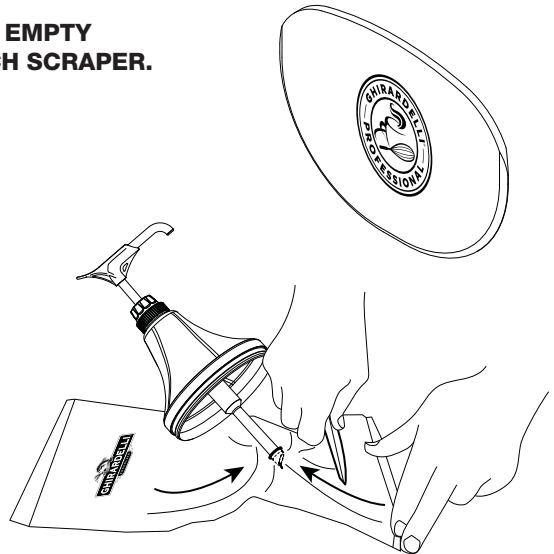

UNIT TAKE-DOWN

- 1 REMOVE PUMP, LID & POUCH**
from shroud.

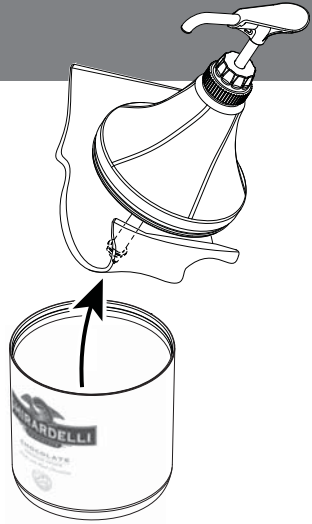

- 2 REMOVE POUCH**
from pump.
Completely empty pouch
may be discarded.

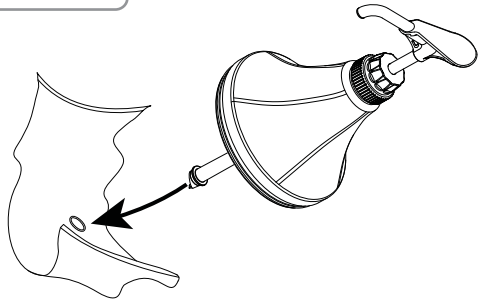

- 3 REMOVE PUMP**
from lid. Loosen cap from
lid threads to release.

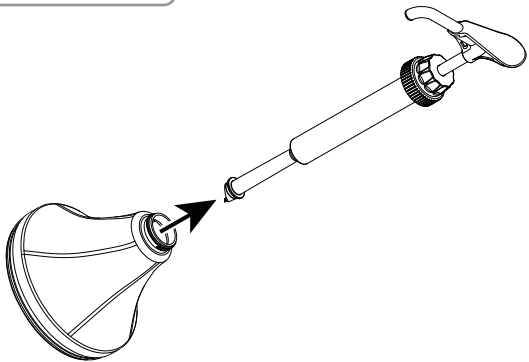

- 4 DISASSEMBLE & CLEAN PUMP**

PUMP DISASSEMBLY

DISASSEMBLE AND WASH

ALL PARTS PROPERLY BEFORE USE. See page 10.

During disassembly, collect small parts in a container to prevent loss.

1 SEPARATE CYLINDER ASSEMBLY & HEAD

Loosen locking collar to release.

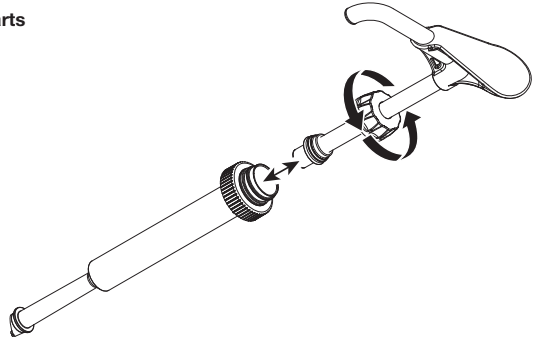

2 REMOVE SPRING & CAP FROM CYLINDER

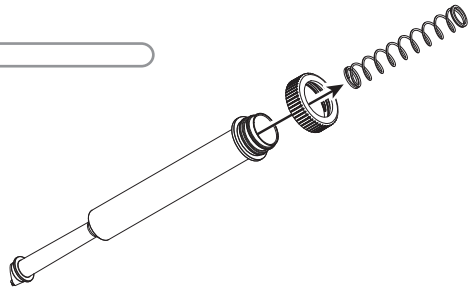

3 REMOVE PINCH VALVE

from head assembly.
Pinch gently and twist to pull valve out.

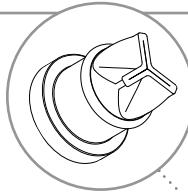

4 REMOVE SEAL

from head assembly by pressing it down and off with thumb.
Do not use a sharp tool.

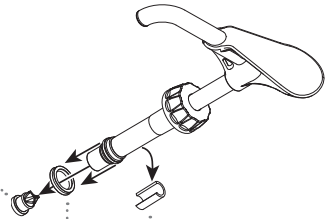

5 REMOVE O-RING FROM SEAL

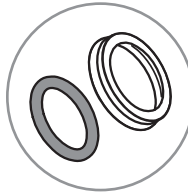

6 REMOVE GAGING COLLAR

PUMP CLEANING

1 FLUSH & RINSE

all pump surfaces with hot water.
Place lower end of pump into container of hot water and operate pump until all remaining product is expelled and only hot water is discharged.

2 DISASSEMBLE & CLEAN

all washable parts with soap and hot water
(See DISASSEMBLY on page 9.)

USE SUPPLIED BRUSH

to thoroughly clean inside discharge tube and any confined areas.

3 RINSE

fully with clear water.

4 SANITIZE

all parts according to local sanitization requirements. All parts in contact with food must be sanitized.

5 AIR DRY

all parts fully.

YES!

Use dishwashing soap, hot water and nylon brush



Pump is dishwasher safe.

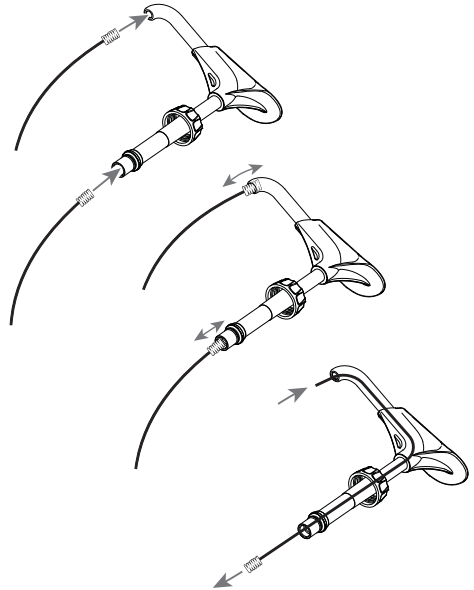

LID & BASE CLEANING

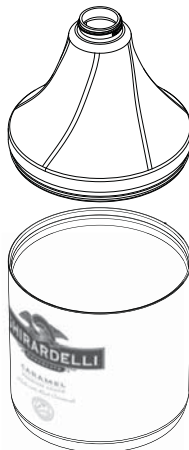

YES!

Use dishwashing soap and hot water to clean lid and base.

DO NOT IMMERSE BASE IN WATER

- A general purpose, nonabrasive cleaner may be used on hard to remove deposits.
- Do not use abrasive, caustic or ammonia based cleansers.
- Do not use cleansing agents with high concentrations of acid, alkaline or chlorine.
- Do not use metal scrapers or cleaning pads that could scratch surfaces.

CLEAN-IN-PLACE PROCEDURE FOR PUMPS

1 CLEAN

- Pump out all (if any) remaining food product from inside pump body.
- Wash and rinse off outside of pump body.
- Flush out and rinse inside of pump.
- Place lower end of pump into container full of water and operate pump until all (if any) remaining product is expelled and only warm water flows from discharge tube.
- Mix 1 tsp (5 mL) of dishwashing detergent with 1 quart (.95 L) of hot tap water (approximately 110°F/43°C).
- Place lower end of pump into cleaning mixture. Pump until all cleaning mixture is expelled.

2 RINSE

- Place lower end of pump into 2 cups (.5 L) of hot tap water (approximately 110°F/43°C) and pump until all tap water is expelled.

3 SANITIZE

- Mix one 1 oz (30 mL) packet of KAY-5 Sanitizer/Cleaner (EPA REG No. 5389-15) with 2.5 gallons (9.5 L) of tap water (approximately room temperature).
- Place lower end of pump into this sanitizing mixture and repeatedly operate pump until 1 quart (.95 L) sanitizing mixture is pumped through pump.

4 RINSE

- Place lower end of pump into 1 cup (.24 L) of hot tap water (approximately 110°F/43°C) and pump until all tap water is expelled.

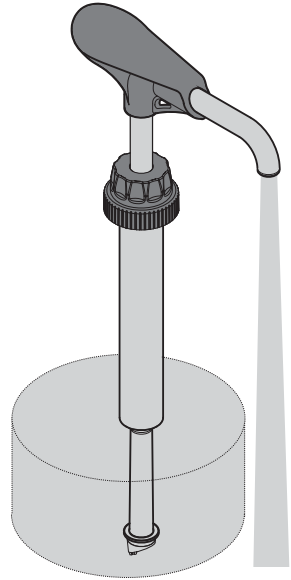

CARE OF STAINLESS STEEL

This durable pump includes stainless steel components.

If you notice corrosion beginning on any stainless steel surface, you may need to change the cleansing agent, sanitizing agent, or the cleaning procedures you are using.

- A mildly abrasive nylon or brass brush may be used to remove any stubborn deposits.

- Fully rinsing and drying all parts can help prevent corrosion. Elements and minerals in tap water can accumulate on stainless steel parts and create corrosion.
- Do not use abrasive, caustic or ammonia based cleansers.
- Do not use products containing acids, alkalines, chlorine, or salt. These agents can corrode stainless steel.
- Do not use metal scrapers or cleaning pads that could scratch surfaces.

TROUBLESHOOTING

PRODUCT OZZES OUT FROM LOCKING COLLAR?

- Ensure that the **cap is securely snapped** into place below all the threading on the cylinder.

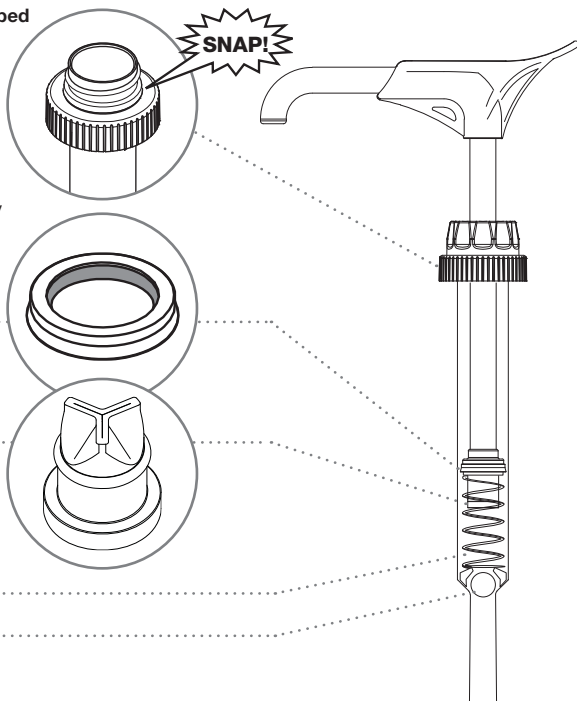

INCONSISTENT PORTIONS?

- **Clean pump.**
- Ensure product container is not empty and has **enough product** to pump.
- Ensure unit is **assembled correctly.**
TIP: Seal has a slight taper. Install with flat side towards top, flared side down.
- Ensure **pinch valve** is installed correctly.
TIP: Squeeze the pinch valve open before installation to ensure it isn't stuck shut.
- Ensure that the **spring** is functional. Replace broken spring if necessary.
- Ensure that the **stainless steel ball** is snapped in place below tabs.

SERVER PRODUCTS LIMITED WARRANTY

2 YEAR
WARRANTY



Server Products equipment is backed by a two-year limited warranty against defects in materials and workmanship.

For complete warranty information go to:

www.Server-Products.com

GENERAL SERVICE, REPAIR OR RETURNS

Before sending any item to Server Products for service, repair, or return, contact Server Products customer service to request a **Return Authorization Number**. Merchandise must be sent to Server Products with this number. Service is extremely prompt. Typically, units are repaired and ship out within 48 hours of receipt.

Merchandise being returned for credit must be in new and unused condition and not more than 90 days old and will be subject to a 20% restocking charge.

NEED HELP?

Server Products Inc.

3601 Pleasant Hill Road
Richfield, WI 53076 USA



262.628.5600 | 800.558.8722



SPSALES@SERVER-PRODUCTS.COM

Please be prepared with your **Series Number** and **Description** located on the unit.

Please refer to pages 2 & 3 for individual **Part Numbers**.