



S E R V E R

SERVE BETTER™

MODELS:

CW

CONSERVEWELL™

120V USA
Series 13E

87730

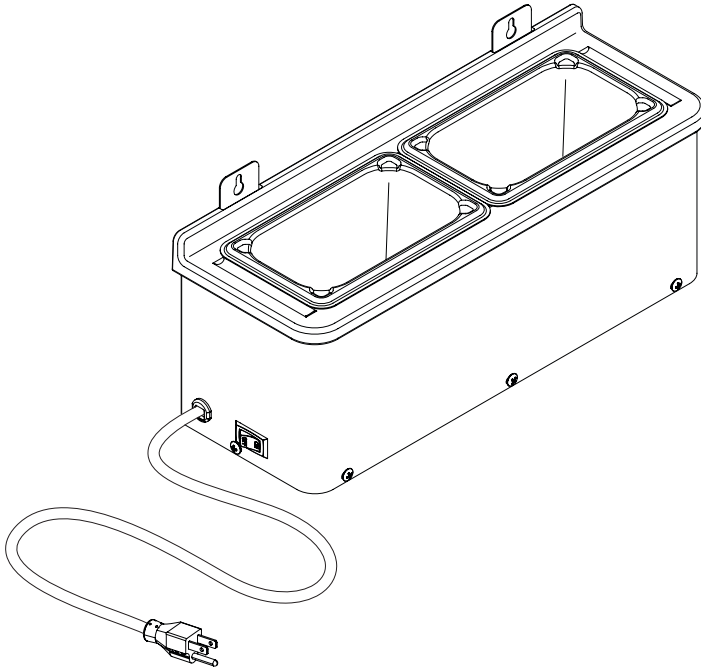

UNIT INSTALLATION

This unit is wall/back surface mountable. Use provided holes on back plate to attach unit to a wall or sturdy countertop/surface.

UNIT SET-UP

ALWAYS CLEAN UNIT THOROUGHLY BEFORE EACH USE. SEE UNIT TAKE-DOWN, SAFETY GUIDELINES, AND CLEANING.

1 INSERT PANS INTO VESSEL/BASIN OF UNIT.

- **DO NOT POUR WATER INTO VESSEL/BASIN.**
- Fill pans with water; approximately 1 quart (.95L) in each pan.
- This unit is not to be used for serving food.
- This unit is only to be used to allow utensils to soak in hot water (approximately 140°F/60°C) for ease in use.
- This unit does not provide self-cleaning of utensils.

2 PLUG CORD INTO POWER SOURCE.



Warning- Electrical shock could occur:

- **This unit must be earthed or grounded.**
- **This requires all three prongs (terminals) on cord plug to be plugged into power source.**

3 TURN UNIT ON.

- Warm-up takes approximately 90 minutes to reach 72°F/22°C to 140°F/60°C.



Caution- Hot: Unit will get HOT.

- Surface temperature of shroud can reach 180°F/82°C, pans can reach 170°F/76°C.

UNIT TAKE-DOWN

1 TURN UNIT OFF.

2 UNPLUG CORD.

ENSURE UNIT IS "OFF" AND UNPLUGGED.



Caution- Hot:

- **If unit has already been in use, unit may still be hot. Allow unit to cool before continuing.**



Warning- Electrical shock could occur:

- **Electrical components of unit could be damaged from water exposure or any liquid.**
- **Never immerse unit into water or any liquid.**
- **Never use any water jet or pressure sprayer on unit.**

3 REMOVE PANS FROM UNIT VESSEL/BASIN.

WIRING DIAGRAM

1 Cord Assembly

120V/60Hz

A Black

B White

C Green

2 Bushing and/or Strain Relief

3 Rocker Switch

4 Thermal Cutout

5 Thermostat

6 Heating Element

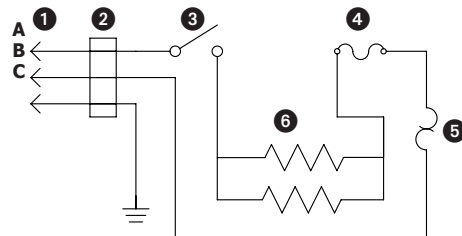

PARTS LIST

PART	QTY	DESCRIPTION
04544	1	SWITCH, SNAP-IN ROCKER
11189	1	CORD ASSEMBLY, 18GA
11201	1	BUSHING, STRAIN RELIEF, 18/3
86301	1	CLAMP, CABLE
87731	1	TOP
87733	1	ELEMENT ASSEMBLY, SILICONE, 200W
87734	1	INSULATION, 5 X 19 1/8
87736	1	VESSEL, DIPPER
87737	1	PANEL, BOTTOM & REAR
87739	1	BRACKET, MOUNTING, REAR
87741	1	BODY ASSEMBLY
87742	1	SHIELD, HEAT
87743	1	CUT-OUT, THERMAL ASSY, 184C, 6.21"
88671	1	THERMOSTAT, 112C (234F)
90106	2	PAN, 1/9 SIZE, 4" DEEP

CW
CONSERVE WELL™
120V USA
Series 13E
87730

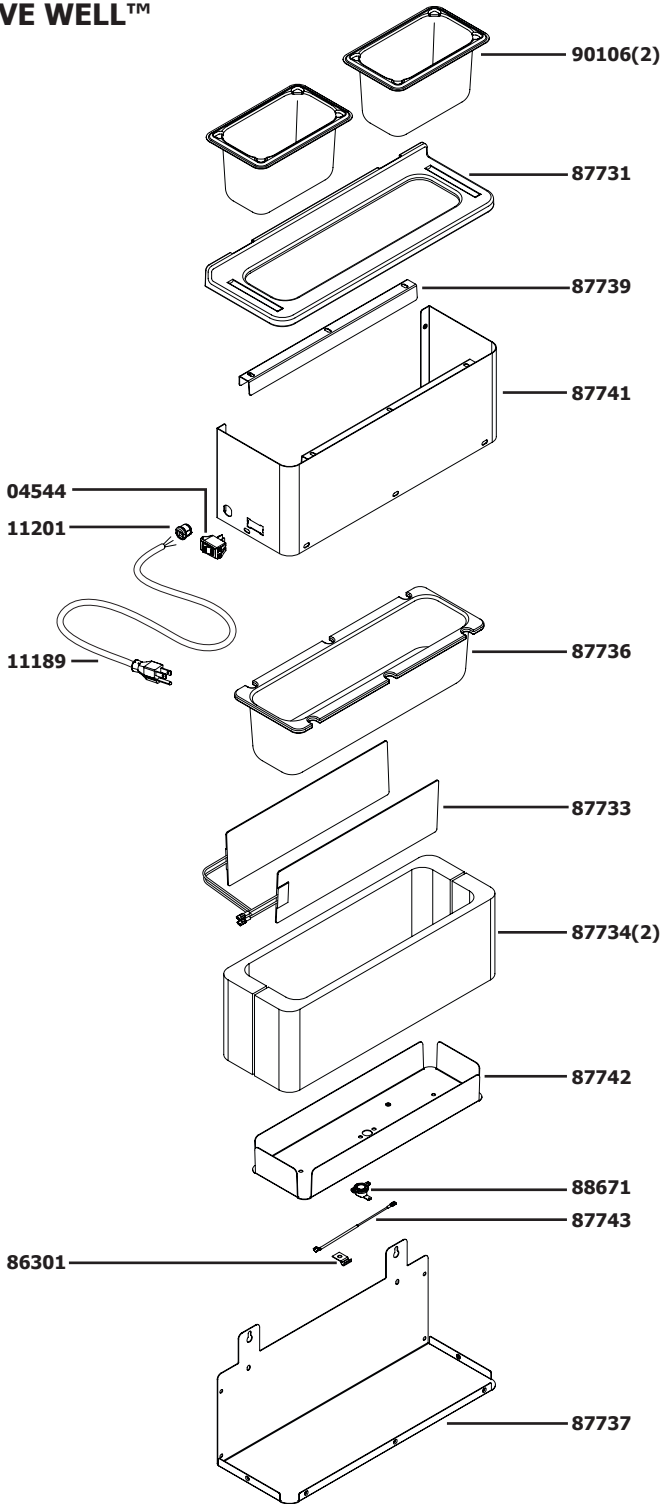

UNIT CLEANING

BEFORE FIRST USE AND AFTER USE DAILY, DISASSEMBLE AND CLEAN UNIT. STAINLESS STEEL PARTS CAN CORRODE. IT IS IMPORTANT TO CLEAN, RINSE, SANITIZE, AND DRY THESE PARTS DAILY AND PROPERLY. FAILURE TO COMPLY WITH ANY OF THESE INSTRUCTIONS MAY VOID UNIT WARRANTY.

- 1 SEE UNIT TAKE DOWN.
- 2 ENSURE UNIT IS "OFF" AND UNPLUGGED.



Caution- Hot:

- If unit has already been in use, unit may still be hot. Allow unit to cool before continuing.



Warning- Electrical shock could occur:

- Electrical components of unit could be damaged from water exposure or any liquid.
 - Never immerse unit into water or any liquid.
 - Never use any water jet or pressure sprayer on unit.
- 3 WASH PANS AND UNIT VESSEL/BASIN WITH DISHWASHING DETERGENT AND HOT WATER DAILY. RINSE THOROUGHLY AND DRY WITH A CLEAN SOFT CLOTH.
 - A general purpose, nonabrasive cleaner may be used on hard to remove food deposits.
 - A mildly abrasive NYLON or brass brush may be used to remove any stubborn food or mineral depositson interior surfaces of unit.
 - Do not use abrasive cleansers, scrapers, steel pads, steel wool, or other cleaning tools that can scratch surfaces.
 - Do not use cleansing agents with high concentrations of acid, alkaline or chlorine. These agents can corrode stainless steel.
 - Fully rinsing all parts can help prevent corrosion.
 - Various elements and minerals, such as chlorides in tap water, can accumulate on stainless steel parts and create corrosion.
 - To prevent corrosion on any stainless steel parts, it is important to fully dry with a clean soft cloth regularly.
 - 4 WIPE EXTERNAL SURFACES OF UNIT DAILY WITH A CLEAN DAMP CLOTH. DRY WITH A CLEAN SOFT CLOTH.
 - A nontoxic glass cleaner may be used for cleaning any stainless steel parts.

UNIT TROUBLESHOOTING

POSSIBLE PROBLEM:

- Unit does not heat.

POSSIBLE SOLUTIONS:

- Ensure cord is securely plugged in.
- Ensure power is available from source.
- Ensure unit is on.



NSF International listed.
(National Sanitation Foundation)
This unit is not to be used for serving food.

GENERAL SERVICE, REPAIR, OR RETURNS

Before sending any item to Server Products for service, repair, or return, contact Server Products customer service to request a **Return Authorization Number**. Merchandise must be sent to Server Products with this number.

Merchandise being returned for credit must be in new and unused condition and not more than 90 days old and will be subject to a 20% (percent) restocking charge. Electrical parts (thermostats, heating elements etc.) are not returnable.

Server Products maintains a fully staffed service department with highly skilled factory trained personnel. Service is extremely prompt. Under normal circumstances, a repaired unit is shipped out the day after it is received. Labor charges are reasonable.

SERVICE

Contact your dealer or Server Products Inc. customer service department for the following:

ORDERING REPLACEMENT PARTS

Be prepared to give this information:

- Model Letters/Name/Numbers
- Part Numbers- P/N
- Series Numbers/Letters
- Part Description

This information and other important data is stamped on the lid or cylinder of pumps or on the bottom or back side of every unit.

Servicing Cord

Specific tools are required for safe and proper power supply cord removal and installation. If cord must be replaced, only a representative of the OEM (original equipment manufacturer) or a qualified technician may replace cord. Cord must meet code designation H05 RN-F requirements.

SERVER PRODUCTS LIMITED WARRANTY

All Server Products equipment is backed by a two-year limited warranty against defects in materials and workmanship. For complete warranty information go to: www.server-products.com



Server Products Inc.

3601 Pleasant Hill Road
Richfield, WI 53076 USA



262.628.5600



800.558.8722



262.628.5110



spsales@server-products.com



www.server-products.com