



S E R V E R

SERVE BETTER™

MODEL:

**PPO-4 PORTION PACK ORGANIZER,
4 COMPARTMENTS,**

PANDA-3 FLAVORS
Series 10L
85621

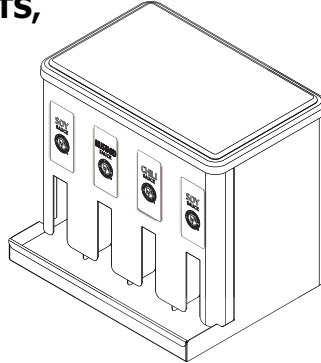

**PPO-3 PORTION PACK ORGANIZER,
3 COMPARTMENTS,**

PANDA-2 FLAVORS
Series 11H
85651

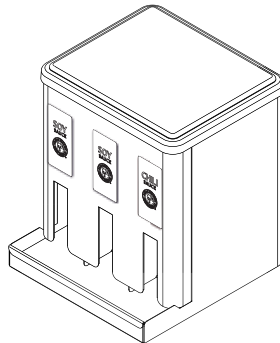

**PPO-4 PORTION PACK ORGANIZER,
4 COMPARTMENTS,**

PANDA-4 FLAVORS
Series 10L
85652

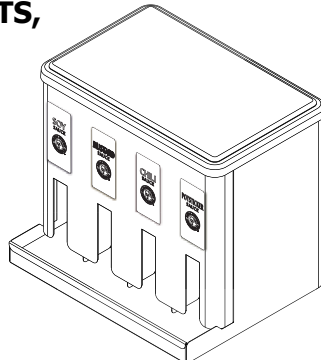

**PPO-4
PORTION PACK ORGANIZER,
4 COMPARTMENTS,**

PANDA-3 FLAVORS

Series 10L

85621

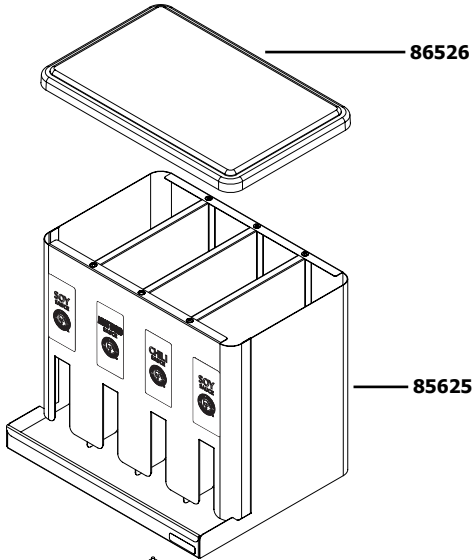

**PPO-3
PORTION PACK ORGANIZER,
3 COMPARTMENTS,**

PANDA-2 FLAVORS

Series 11H

85651

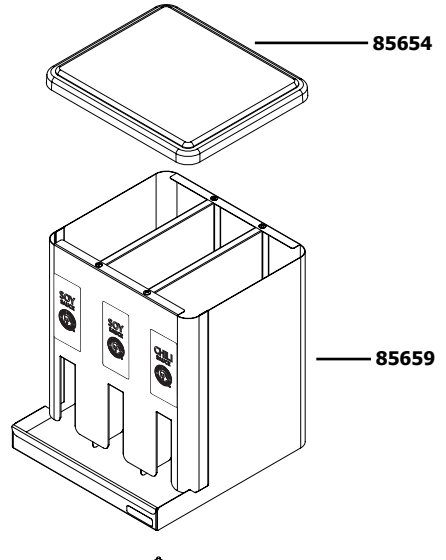

◆ — **81169(4)**

◆ — **81169(4)**

| | |
|--------------|--------------------------------|
| 81169 | FOOT, W/SCREW |
| 85625 | SHROUD ASSEMBLY |
| 85626 | LID, PPO-4 |
| 85631 | DECAL, MUSTARD SAUCE |
| 85632 | DECAL, CHILI SAUCE |
| 85633 | DECAL, SOY SAUCE |
| 85653 | DECAL, POTSTICKER SAUCE |
| 85654 | LID, PPO-3 |
| 85659 | SHROUD ASSEMBLY |

PPO-4 PORTION PACK ORGANIZER, 4 COMPARTMENTS,

PANDA-4 FLAVORS

Series 10L

85652

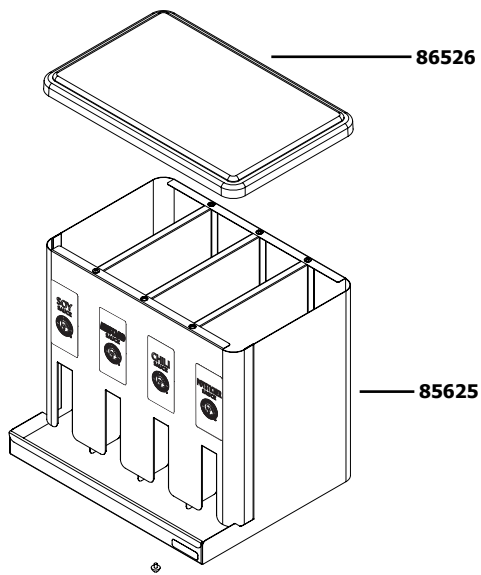

◆ — **81169(4)**

SAFETY GUIDELINES

According to food and safety regulations, most foods must be stored and/or served at certain temperatures or they could become hazardous. Check with local food and safety regulators for specific guidelines.

Stainless steel is one of the best materials for food serving and storage, but there are many products which can corrode it. If you notice corrosion beginning on any stainless steel surface, you may need to change the cleansing agent, sanitizing agent, or the cleaning procedures you are using.

- Products containing: acids, alkalines, chlorine, or salt can corrode stainless steel.
- Sauerkraut and Au Jus sauces corrode stainless steel. Server Products, Inc. regrets that we can not honor Warranty claims on stainless steel parts that have been affected by sauerkraut or Aus Jus.

Plastic Lid, Plastic Cover, Plastic Top or Plastic Organizer Pan

- Not dishwasher safe.
- Hand Wash Only.

Do not place plastic lid, plastic cover, plastic top or plastic organizer pan under, in, or near to high heat, as this can melt the plastic.

CLEANING UNIT

BEFORE FIRST USE AND AFTER USE DAILY OR REGULARLY, DISASSEMBLE AND CLEAN PARTS. FOR SAFE AND PROPER CARE, AND TO PREVENT CORROSION, OF PARTS, IT IS IMPORTANT TO CLEAN, RINSE, SANITIZE, AND DRY PARTS DAILY OR REGULARLY. FAILURE TO COMPLY WITH ANY OF THESE INSTRUCTIONS MAY VOID UNIT WARRANTY.

- 1** WASH CLEAN ALL PARTS WITH DISHWASHING DETERGENT AND HOT WATER.
 - Do not use scrapers, steel pads, steel wool, or other cleaning tools that can scratch surfaces.
 - Mildly abrasive NYLON or brass brush may be used to remove any stubborn food or mineral deposits on interior surfaces of unit.
 - Do not use abrasive cleansers.
 - Do not use caustic cleansers.
 - Do not use cleansing agents with high concentrations of acid, alkaline or chlorine.
 - Do not use ammonia based cleansers.
- 2** FULLY RINSE ALL WASHED PARTS THOROUGHLY WITH CLEAR WATER.
 - To prevent corrosion on parts, it is important to thoroughly and fully rinse washed parts.
- 3** WIPE CLEAN EXTERNAL SURFACES OF UNIT WITH A CLEAN DAMP CLOTH.
 - Nontoxic glass cleaner may be used to clean stainless steel parts.
- 4** DRY ALL PARTS WITH A CLEAN SOFT CLOTH.
 - Various elements and minerals, such as chlorides in tap water, can accumulate on stainless steel parts and create corrosion.
 - To prevent corrosion on stainless steel parts, it is important to thoroughly and fully dry with a clean soft cloth regularly.
- 5** SANITIZE ALL PARTS FOLLOWING LOCAL SANITIZATION REQUIREMENTS. ALL PARTS IN CONTACT WITH FOOD MUST BE SANITIZED.
 - Allow parts to fully air dry after sanitization.

GENERAL SERVICE, REPAIR, OR RETURNS

Before sending any item to Server Products for service, repair, or return, contact Server Products customer service to request a **Return Authorization Number**. Merchandise must be sent to Server Products with this number.

Merchandise being returned for credit must be in new and unused condition and not more than 90 days old and will be subject to a 20% (percent) restocking charge. Electrical parts (thermostats, heating elements, etc.) are not returnable.

Server Products maintains a fully staffed service department with highly skilled factory trained personnel. Service is extremely prompt. Under normal circumstances, a repaired unit is shipped out the day after it is received. Labor charges are reasonable.

SERVICE

Contact your dealer or Server Products Inc. customer service department for the following:

ORDERING REPLACEMENT PARTS

Be prepared to give this information:

- Model Letters/Name/Numbers
- Part Numbers- P/N
- Series Numbers/Letters
- Part Description

This information and other important data is stamped on the lid or cylinder of pumps or on the bottom or back side of every unit.

SERVER PRODUCTS LIMITED WARRANTY

All Server Products equipment is backed by a two-year limited warranty against defects in materials and workmanship. For complete warranty information go to: www.server-products.com



Server Products Inc.

3601 Pleasant Hill Road
Richfield, WI 53076 USA



262.628.5600



800.558.8722



262.628.5110



spsales@server-products.com



www.server-products.com