



S E R V E R

SERVE BETTER™

Chiller 1/3 SLANTED STAND KIT

MODEL:
85537

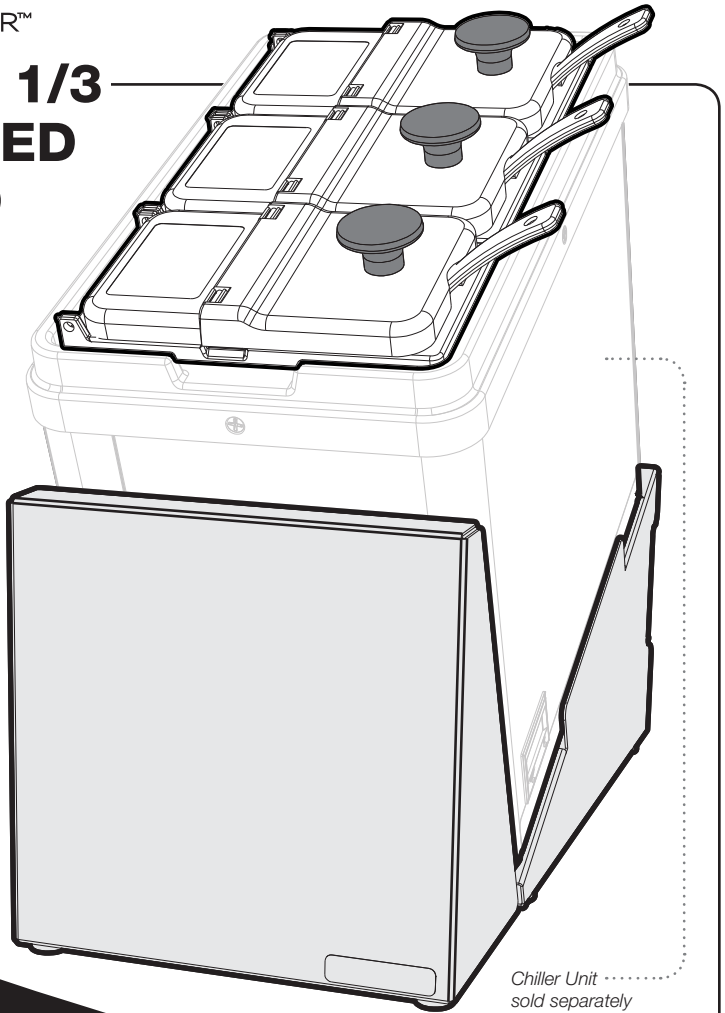

Chiller Unit
sold separately

Thank You

...for purchasing our Chiller 1/3 Slanted Stand Kit. This stand puts chilled condiments in easy reach. Each of the three 1/9 size jars include a spoon for 1/2 oz portions.

CHILLED SERVING CONVENIENCE

QUICK START

This Stand Kit is to be used with a Condiment Chiller Unit.

1 PREPARE CHILLER UNIT

- Ensure the power is turned off and unit is unplugged.

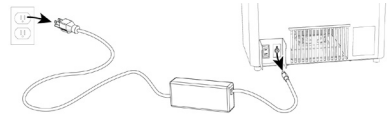

2 PLACE CHILLER INTO STAND

- Insert each of the Chiller's four feet into the holes in the Slanted Stand.
- Place the unit so that the power switch is in the back left corner.

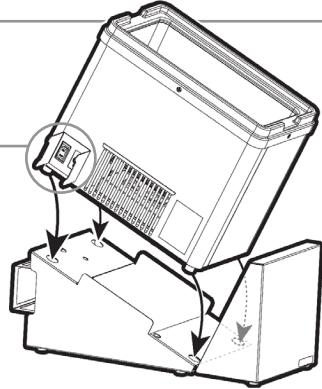

3 PLACE JARS, LIDS AND SPOONS INTO THE CHILLER

- Practice food safety. Wash and sanitize all parts thoroughly according to local sanitation regulations before use.
- See page 3.

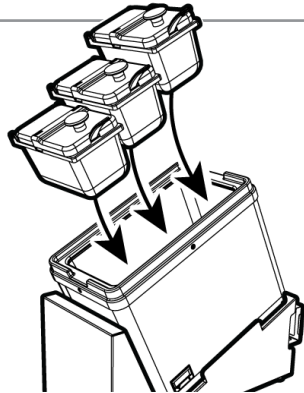

4 INSERT THE POWER SUPPLY & PLUG

- Insert power supply into the side of the back bracket.
- Insert the plug into the power inlet.

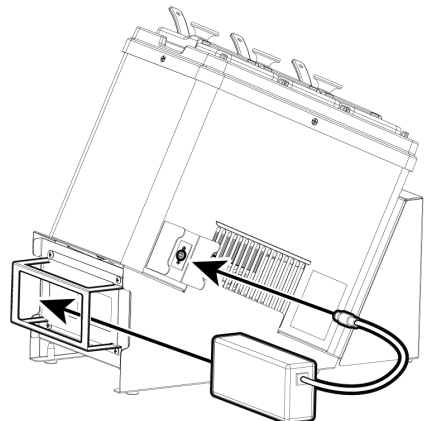

SAFETY



According to food and safety regulations, most foods must be stored and/or served at certain temperatures or they could become hazardous. Check with local food and safety regulators for specific guidelines.

Be aware of the product you are serving and the temperature the product is required to maintain. Server Products, Inc. cannot be responsible for the serving of potentially hazardous product.



NSF International listed.
(National Sanitation Foundation)



WARNING

**Electrical shock could occur:
The unit must be earthed or grounded.
This requires all three prongs (terminals) on the cord plug to be plugged into power source.**



IMPORTANT

Clean, rinse, sanitize, and dry parts daily or regularly to comply with local sanitization requirements.

CLEANING



CLEAN THE STAND

- Sanitize according to local sanitization requirements. All parts in contact with food must be sanitized.
- External surfaces may be wiped clean with a clean damp cloth.
- Glass and surface cleaners approved for use in food contact areas may be used.
- Do not use abrasive, caustic or ammonia based cleansers.
- Do not use metal scrapers or cleaning pads that could scratch surfaces.

CLEAN THE JARS, LIDS & SPOONS

- Wash with soap and hot water.
- Rinse fully with clean water.
- Sanitize according to local sanitization requirements. All parts in contact with food must be sanitized.
- Air dry fully or wipe with a clean dry cloth.

WARNING

Ensure that unit is OFF and unplugged. Electrical components of Chiller unit could be damaged from water exposure or any liquid. Never immerse unit into water or any liquid. Never use any water jet or pressure sprayer on unit.

Refer to separate instruction manual to clean the Chiller.



YES!

Use dishwashing soap and hot water



Please Visit
www.YouTube.com/user/ServerProducts
to see videos of more information.



CHILLER 1/3 SLANTED STAND KIT

MODEL: 85537

PART	QTY	DESCRIPTION
87253	3	LID ASSEMBLY, PLASTIC, 1/9 SIZE
85156	3	SPOON, 1/2 OZ
87202	3	JAR, 1/9 SIZE, 3.5" DEEP, BLACK
85556	1	RACK ASSEMBLY, SLANTED, 1/3 CHILLER
87429	6	<i>Included in Rack Assembly:</i> FOOT, RUBBER

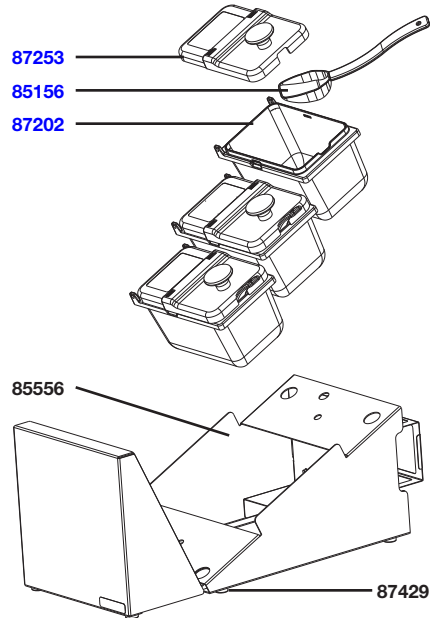

SERVER PRODUCTS LIMITED WARRANTY

2
YEAR
WARRANTY



All Server Products equipment is backed by a two-year limited warranty against defects in materials and workmanship.

For complete warranty information go to:

www.Server-Products.com

GENERAL SERVICE, REPAIR OR RETURNS

Before sending any item to Server Products for service, repair, or return, contact Server Products customer service to request a Return Authorization Number.

Merchandise must be sent to Server Products with this number.

Merchandise being returned for credit must be in new and unused condition and not more than 90 days old and will be subject to a 20% (percent) restocking charge.

Server Products maintains a fully staffed service department with highly skilled factory trained personnel. Service is extremely prompt. Under normal circumstances, a repaired unit is shipped out the day after it is received. Labor charges are reasonable.

HELP or ORDERING REPLACEMENT PARTS

Server Products Inc.

3601 Pleasant Hill Road
Richfield, WI 53076 USA



262.628.5600 | 800.558.8722



SPSALES@SERVER-PRODUCTS.COM

Please be prepared with your **Part Number**, **Series Number** and **Description**. On the stand, this is located on label visible when the Chiller is removed. On the jars and lids, this info is molded into the plastic. Individual parts listed above.