

## Service Parts

This is the illustrated service parts list for the NH0422, NS0422, FS0522, NH0622, NS0622, FS0822, NH0922, NS0922, FS1222, NH1322, NS1322, FS1522 air cooled, water cooled or remote air cooled ice machine heads.

Several models are listed together, be sure to select the correct part based on the complete model number, including voltage.

Voltage codes:

- -1 = 115/60/1
- -32 = 208-230/60/1
- -3 = 208-230/60/3
- -6 = 230/50/1

## Contents

Exterior - NH0422, NS0422, FS0522, NH0622, NS0622, FS0822 .....	Page 2
Exterior - NH0922, NS0922, FS1222, NH1322, NS1322, FS1522.....	Page 3
Interior Cabinet, Water, and Chute Systems .....	Page 4
Refrigeration Condensing, Air Cooled .....	Page 5
Condenser Fan Motor System - NH0422, NS0422, FS0522, NH0622, NS0622, FS0822 .....	Page 6
Condenser Fan Motor System - NH0922, NS0922, FS1222, NH1322, NS1322, FS1522 .....	Page 7
Refrigeration Condensing, Water Cooled .....	Page 8
Refrigeration Condensing, Remote Cooled .....	Page 9
Remote Condenser - ERC111 or ERC311 .....	Page 10
Evaporator System, Hard Nugget (NH) .....	Page 11
Gear Reducer and Motor .....	Page 12
Electrical & Control Box .....	Page 13
Compressors and Hardware .....	Page 14
Wiring Diagrams .....	Page 15

# Service Parts

Exterior - NH0422, NS0422, FS0522, NH0622, NS0622, FS0822

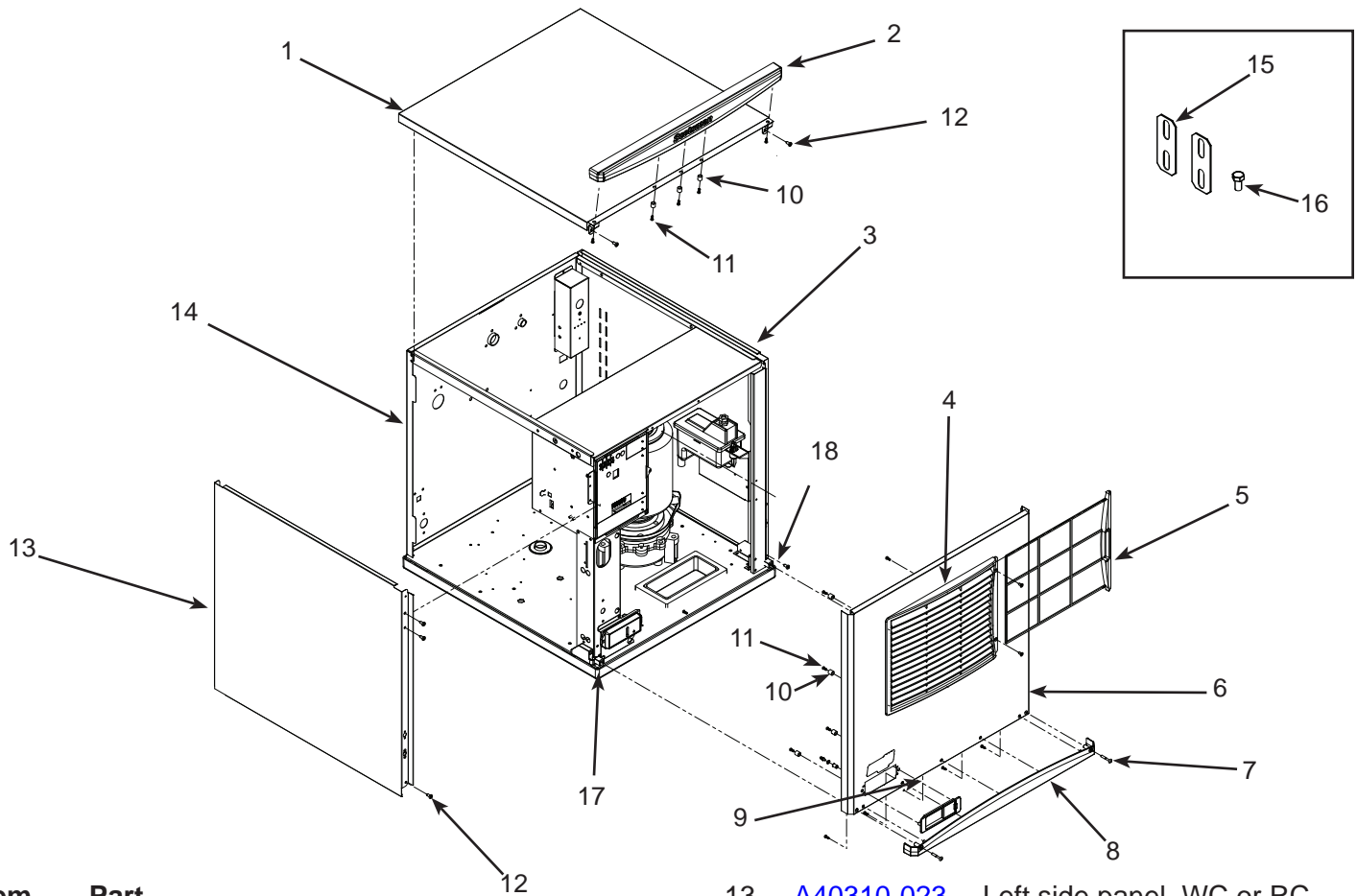

Item Number	Part Number	Description
1	A40309-022	Top panel, includes item 2
2	02-4819-02	Trim strip
3	A40335-021	Right side panel
4	02-4224-03	Louvers
5	02-4212-03	Air filter
6	A40308-025	Front panel, AC includes items 4, 5, 7, 8 and 9
6a	A40308-026	Front panel, WC or RC. Includes items 4, 5, 7, 8 and 9
7	03-1735-03	Screw
8	02-4820-02	Trim strip
9	02-4821-02	Bezel, includes standard door
9a	02-4822-02	Door, bezel secure
10	02-4824-01	Spacer
11	03-3836-02	Screw
12	03-1404-10	Screw
13	A40310-023	Left side panel, WC or RC
	A40310-021	Left side panel, AC
14	A41013-002	Back panel, WC or RC
15	A30911-015	Machine straps
16	03-1405-15	Screw
17	02-4823-21	*Panel mount kit, left
18	02-4823-22	*Panel mount kit, right

\*Includes both screw receptacles

# Service Parts

## Exterior - NH0922, NS0922, FS1222, NH1322, NS1322, FS1522

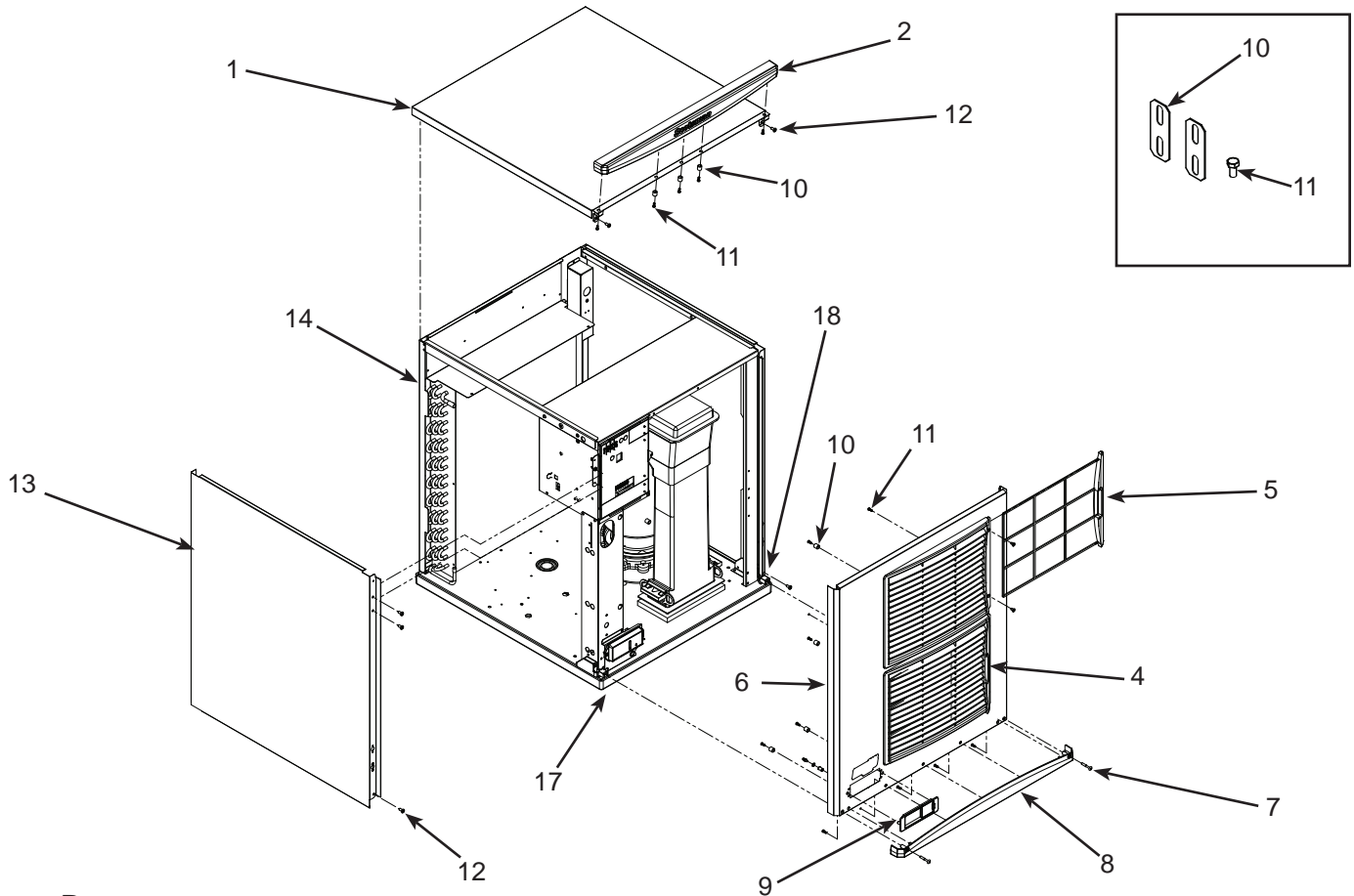

Item Number	Part Number	Description
1	<a href="#">A40309-022</a>	Top panel, includes item 2
2	<a href="#">02-4819-02</a>	Trim strip
3	<a href="#">A40335-022</a>	Right side panel
4	<a href="#">02-4224-03</a>	Louvers
5	<a href="#">02-4212-03</a>	Air filter
6	<a href="#">A40308-028</a>	Front panel, AC includes items 4, 5, 7, 8 and 9
6a	<a href="#">A40308-029</a>	Front panel, WC or RC. Includes items 4, 5, 7, 8 & 9
7	<a href="#">03-1735-03</a>	Screw
8	<a href="#">02-4820-02</a>	Tim strip
9	<a href="#">02-4821-02</a>	Bezel, includes standard door
9a	<a href="#">02-4822-01</a>	Door, bezel with handle
9b	<a href="#">02-4822-02</a>	Door, bezel secure
10	<a href="#">02-4824-01</a>	Spacer
11	<a href="#">03-3836-02</a>	Screw
12	<a href="#">03-1404-10</a>	Screw
13	<a href="#">A40310-025</a>	Left side panel, AC
	<a href="#">A40310-026</a>	Left side panel, WC or RC
14	<a href="#">A41013-001</a>	Back panel, WC or RC
15	<a href="#">A30911-015</a>	Machine straps
16	<a href="#">03-1405-15</a>	Screw
17	<a href="#">02-4823-21</a>	*Panel mount kit, left
18	<a href="#">02-4823-22</a>	*Panel mount kit, right

\*Includes both screw receptacles

# Service Parts

## Interior Cabinet, Water, and Chute Systems

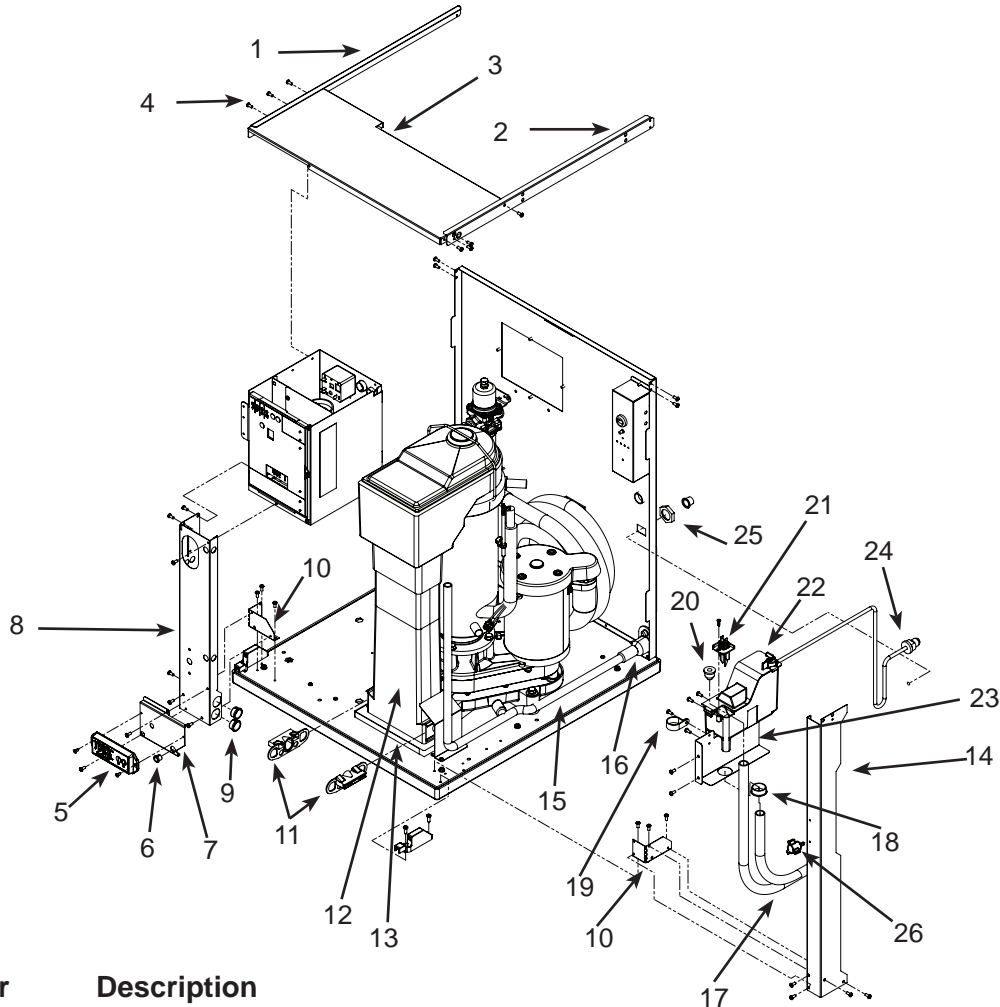

Item Number	Part Number	Description
1	A40361-001	Channel, top left
2	A40362-001	Channel, top right
3	A41005-001	Control box cover
4	03-1531-01	Screw
5	11-0622-21*	Lower display
*(includes bracket, membrane switch, harness)		
6	12-1213-04	Bushing
7	A40363-001	Bracket
8	A40364-001	Support post, front left, short
	A40357-001	Support post, front left, tall
9	12-1213-10	Bushing
10	A40367-001	Bracket, support post
11	A37708-021	Bin control set (2)
12	02-2929-03	Lower ice chute, short
	02-2929-04	Lower ice chute, tall
13	02-4357-01	Ice chute gasket
14a	A41004-001**	Support post, front left, short
	A41003-001**	Support post, front right, tall
14b	A41186-001***	Support post, front right
	A40364-001***	Support post, front left
15	02-5106-01	Drain tube
16	02-3692-04	Drain adapter
17a	A40189-001**	Evaporator inlet hose, short
	02-4752-01**	Evaporator inlet hose, tall
17b	A41197-001***	Evaporator supply tube.
18	12-1213-11	Bushing
19	03-3841-02	Loop clamp for drain tube
20	13-0973-01	Drain plug, vented
21	A40666-001	Water sensor
22	A40664-001	Water reservoir & valve
23a	A40029-001*	Water reservoir bracket
23b	A41187-001**	Water reservoir bracket
24	A41014-001	Water inlet assembly
25	03-1394-01	Pal nut
26	03-1675-04***	Thumb Screw

Short - NH0422, NS0422, FS0522, NH0622, NS0622, FS0822

Tall - NH0922, NS0922, FS1222, NH1322, NS1322, FS1522

\*\* = A series model

\*\*\* = B series model

## Service Parts

### Refrigeration Condensing, Air Cooled

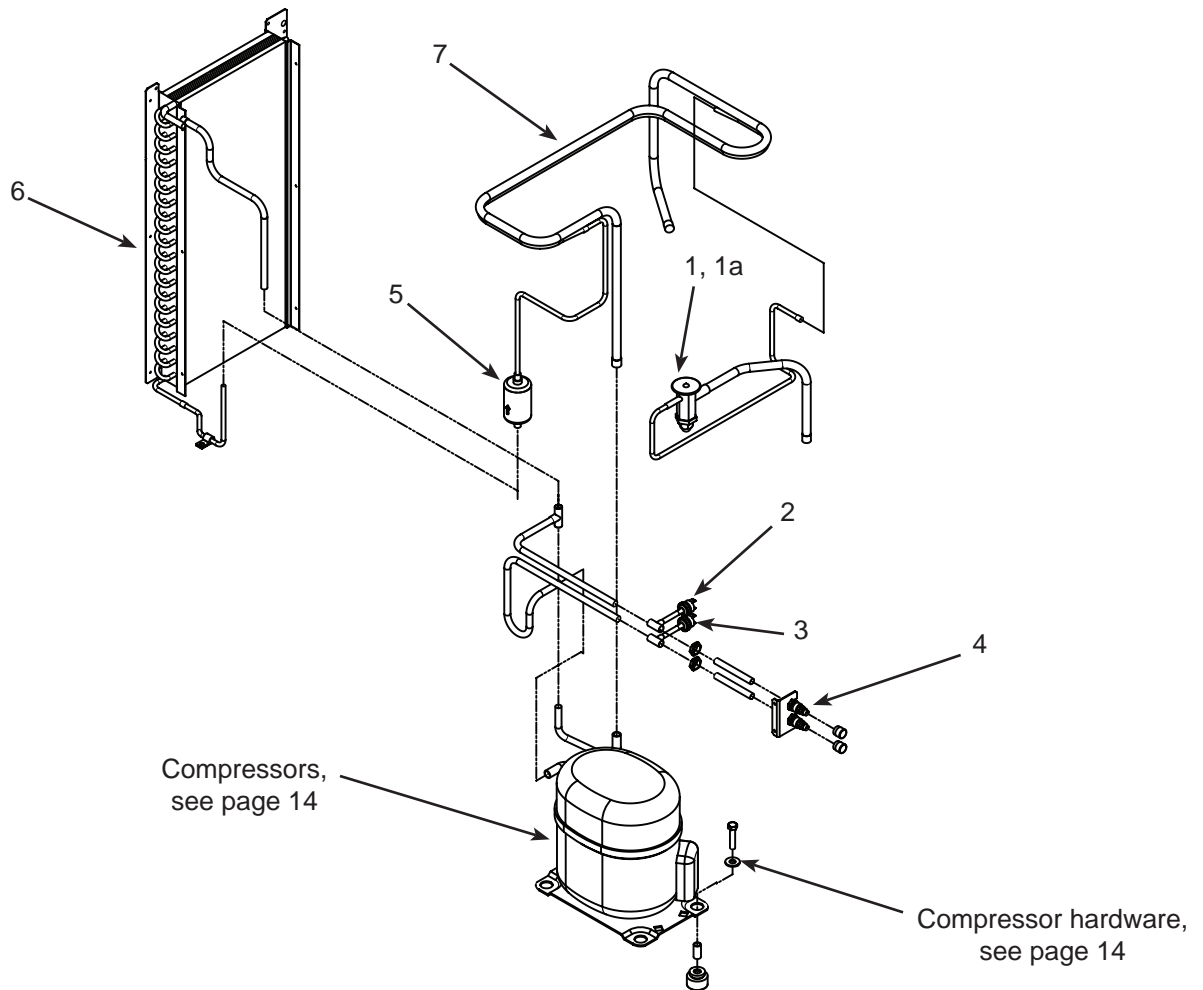

Item Number	Part Number	Description
1	16-1144-21	TXV, NH0422, NS0422, FS0522
	16-1144-22	TXV, NH0622, NS0622, FS0822
	16-1144-24	TXV, NH0922, NS0922, FS1222
	16-1144-23	TXV, NH1322, NS1322, FS1522
1a	02-4406-01	Insulation, TXV
2	11-0501-22	High pressure cut out sw
3	11-0502-21	Low pressure cut out sw
4	16-1137-01	Access valve seat
4a	16-1139-01	Access valve core
4b	16-1140-01	Access valve cap
5	02-3319-01	Filter dryer
6	18-8890-01	Air cooled condenser, fits N0422, F0522, N0622, F0822
	18-8935-01	Air cooled condenser, fits N0922, F1222,
	18-8936-01	Air cooled condenser, fits N1322, F1522
7	A41076-001	Heat Exchanger

## Service Parts

### Condenser Fan Motor System - NH0422, NS0422, FS0522, NH0622, NS0622, FS0822

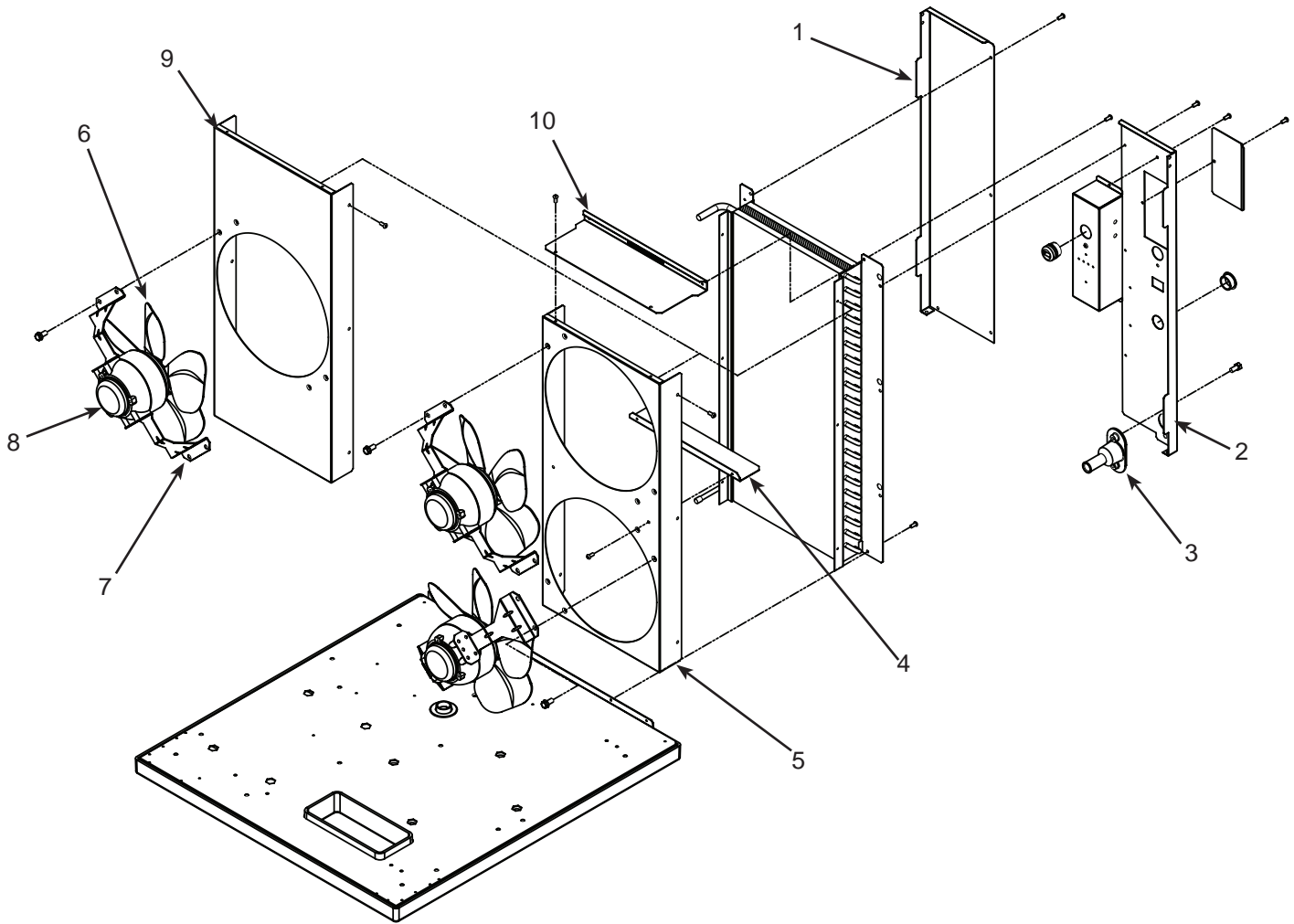

Item Number	Part Number	Description
1	<a href="#">A40651-001</a>	Condenser flange
2	<a href="#">A41012-001</a>	Condenser flange
3	<a href="#">02-3692-21</a>	Drain fitting
4	<a href="#">A38675-001</a>	Shroud divider
5	<a href="#">A39351-001</a>	Shroud, N0622, F0822
6	<a href="#">18-8836-01</a>	Fan blade
7	<a href="#">A38480-001</a>	Bracket, fan motor
8	<a href="#">12-1681-23</a>	Fan motor, 115 volt
	<a href="#">12-1681-04</a>	Fan motor, 208-230 volt/50 or 60 Hz
9	<a href="#">A39350-001</a>	Shroud, N0422, F0522
10	<a href="#">A39352-001</a>	Shroud top

## Service Parts

### Condenser Fan Motor System - NH0922, NS0922, FS1222, NH1322, NS1322, FS1522

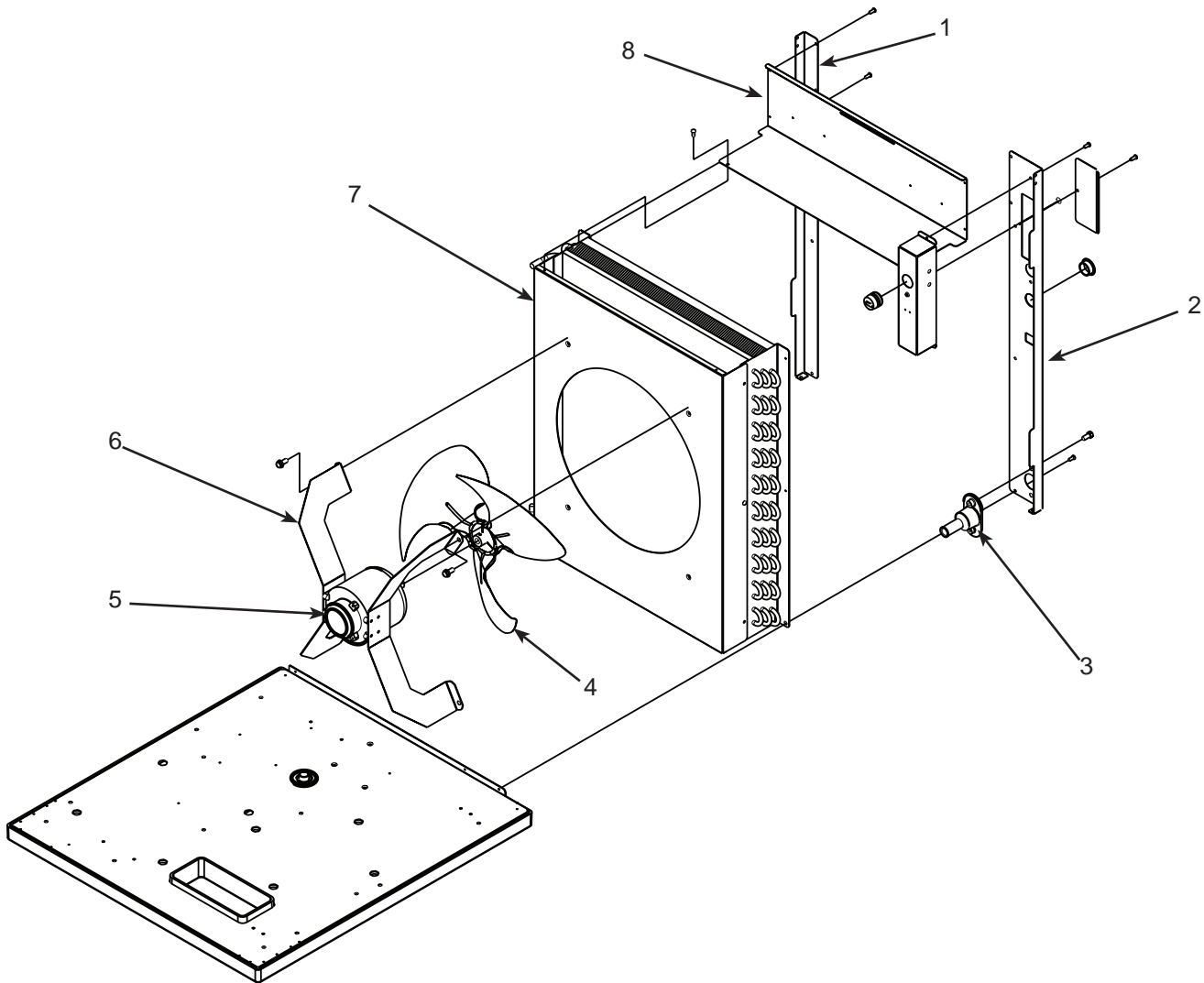

Item Number	Part Number	Description
1	<a href="#">A39188-001</a>	Condenser flange
2	<a href="#">A41011-001</a>	Condenser flange
3	<a href="#">02-3692-21</a>	Drain fitting
4	<a href="#">18-8882-01</a>	Fan blade
5	<a href="#">18-8927-01</a>	230V Fan motor
5a	<a href="#">18-8926-01</a>	115V Fan Motor
6	<a href="#">A40156-001</a>	Bracket, fan motor
7	<a href="#">A39193-001</a>	Shroud
8	<a href="#">A39353-001</a>	Shroud top

# Service Parts

## Refrigeration Condensing, Water Cooled

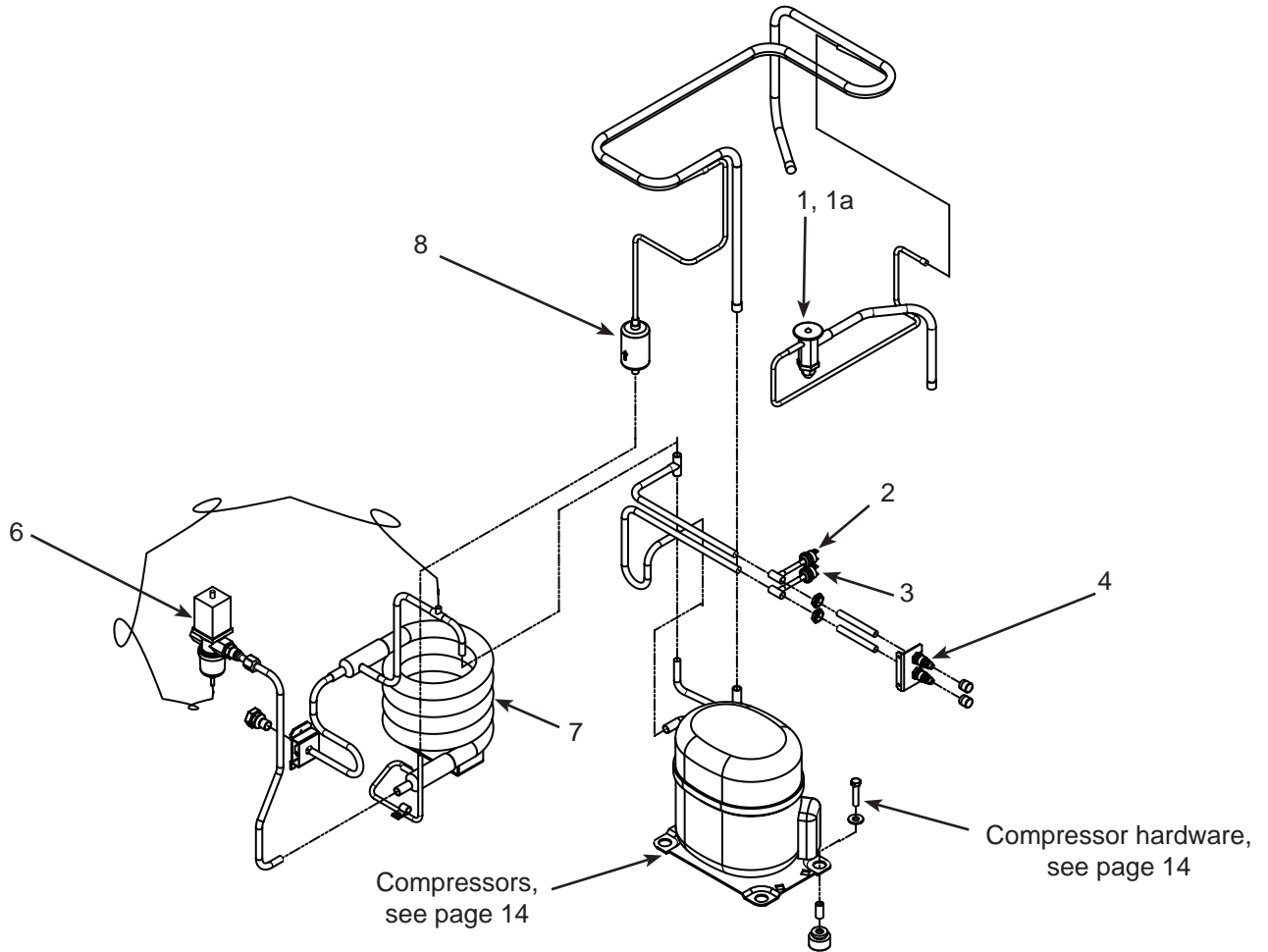

Item Number	Part Number	Description
1	16-1144-21	TXV, NH0422, NS0422, FS0522
	16-1144-22	TXV, NH0622, NS0622, FS0822
	16-1144-24	TXV, NH0922, NS0922, FS1222
	16-1144-23	TXV, NH1322, NS1322, FS1522
1a	19-0599-06	Insulation, TXV
2	11-0501-22	High pressure cut out sw
3	11-0502-21	Low pressure cut out sw
4	16-1137-01	Access valve seat
4a	16-1139-01	Access valve core
4b	16-1140-01	Access valve cap
5	16-1154-22	Condenser drain fitting
6	11-0608-24	Water regulating valve
	18-8871-01	Condenser, water cooled fits NH0422, NS0422, FS0522, NH0622, NS0622, FS0822, NH0922, NS0922, FS1222
7	18-8893-21	Condenser, water cooled fits NH1322, NS1322, and FS1522
	16-0874-01	Receiver, not shown, fits FS1222W or NS0922W
8	02-3319-01	Filter dryer

# Service Parts

## Refrigeration Condensing, Remote Cooled

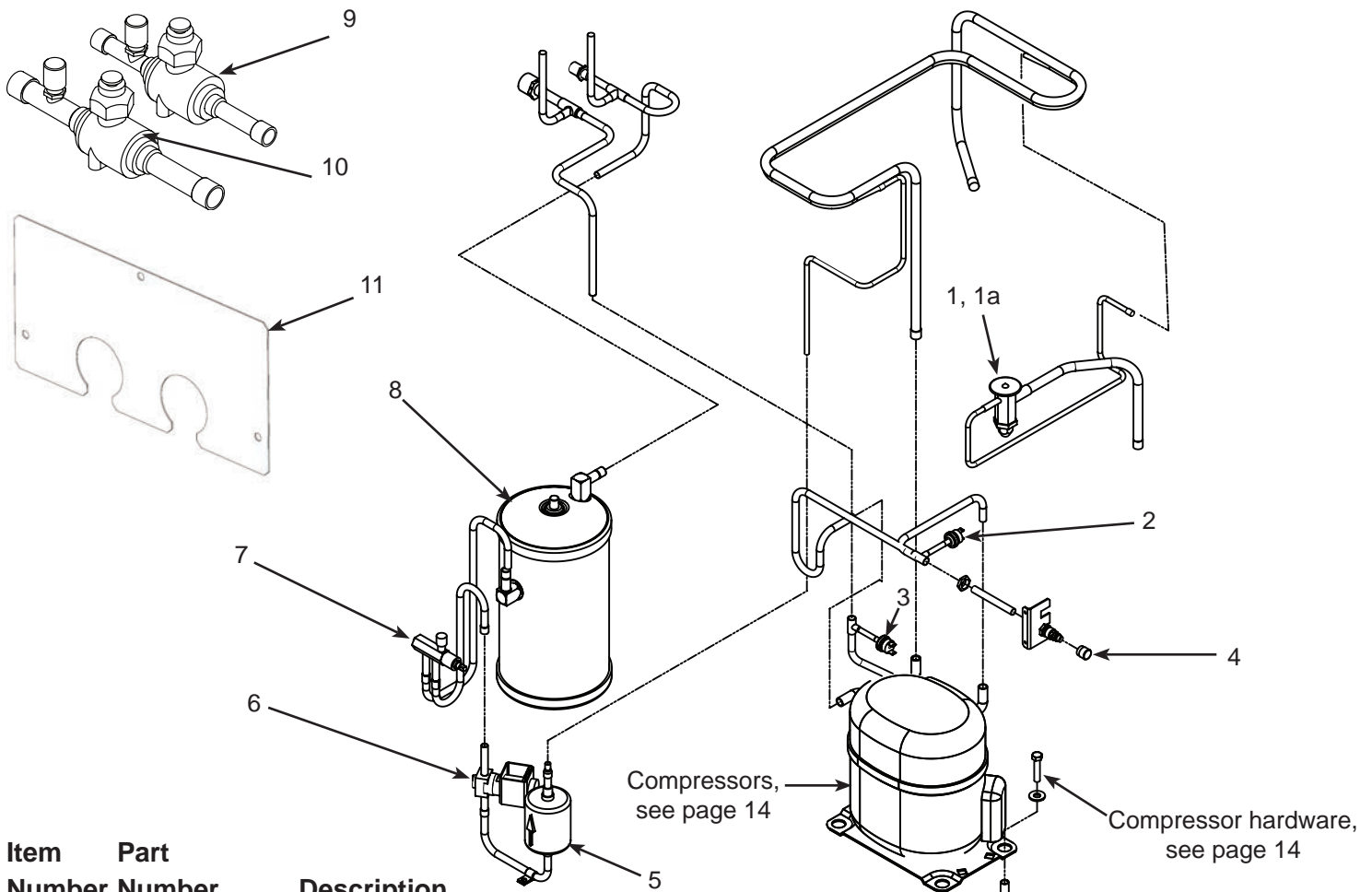

Item Number	Part Number	Description
1	16-1144-21	TXV, NH0422, NS0422, FS0522
	16-1144-22	TXV, NH0622, NS0622, FS0822
	16-1144-24	TXV, NH0922, NS0922, FS1222
	16-1144-23	TXV, NH1322, NS1322, FS1522
1a	02-4406-01	Insulation, TXV
2	11-0502-21	Low pressure cut out sw
3	11-0501-22	High pressure cut out sw
4	16-1137-01	Access valve seat
4a	16-1139-01	Access valve core
4b	16-1140-01	Access valve cap
5	02-3319-02	Filter dryer
6	11-0493-01	Liquid line solenoid valve, 208-230 volt, 50/60 Hz
	12-2719-22	230 volt coil
	11-0493-02	Liquid line solenoid valve, 115 volt
	12-2719-21	115 volt coil
	12-2733-30	LLV/HGV rebuild kit
7	16-1030-01	Receiver outlet valve
8	16-1176-01	Receiver
8	A40772-001	Bucket, receiver bottom
9	16-1208-01	Isolation valve 3/8
10	16-1208-02	Isolation valve 1/2
11	A40508-001	Isolation valves cover order 2
12	A40507-001	Isolation valves bracket

# Service Parts

## Remote Condenser - ERC111 or ERC311

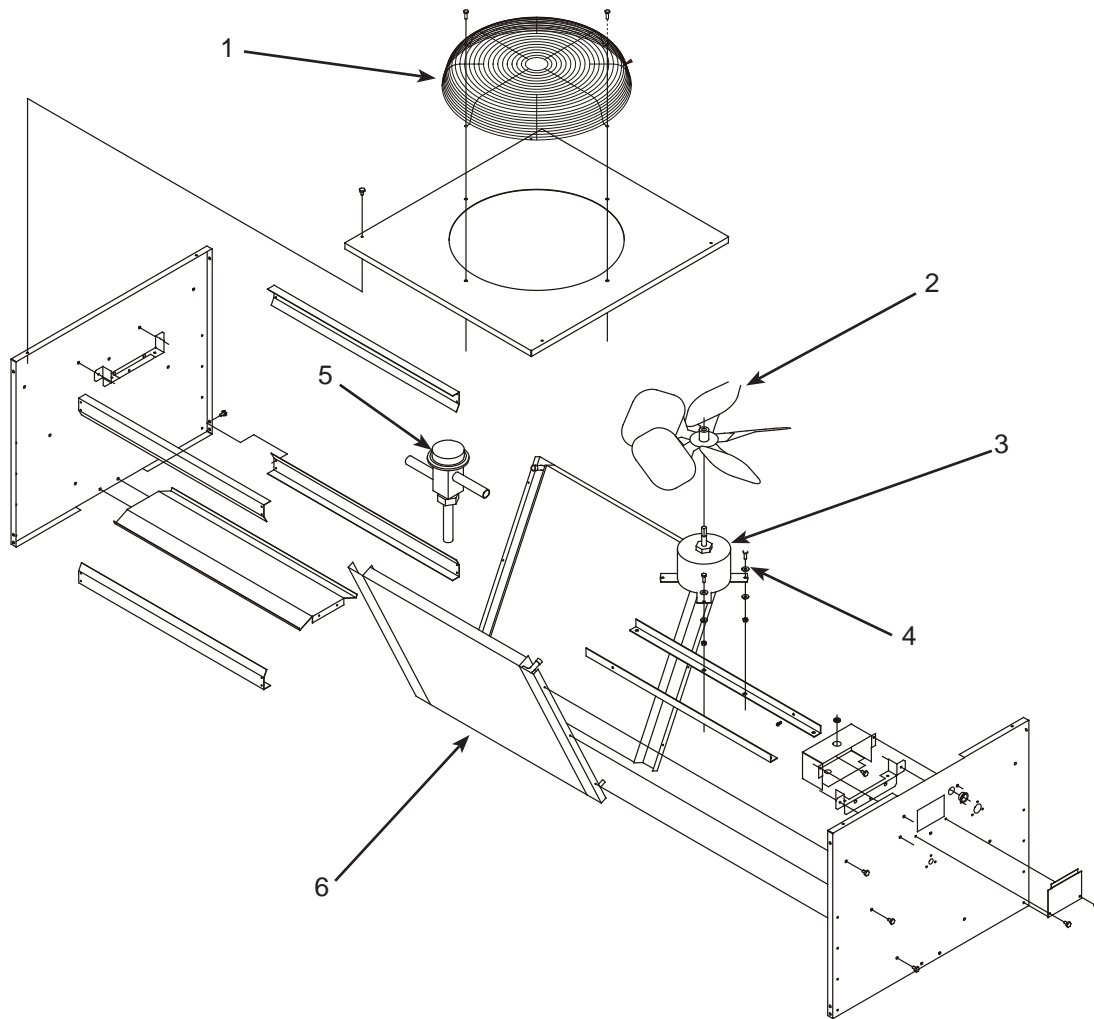

Item Number	Part Number	Description
1	<a href="#">02-3575-01</a>	Fan guard
2	<a href="#">18-8816-01</a>	Fan blade
3	<a href="#">12-2651-01</a>	Fan motor - ERC311 (208-230 volt)
	<a href="#">12-2651-02</a>	Fan motor - ERC111 (115 volt)
4	<a href="#">03-1405-08</a>	Screw
5	<a href="#">11-0422-22</a>	Headmaster
6	<a href="#">18-8827-01</a>	Coil

Not shown:

- NS1 [A37169-001](#) Leg
- NS2 [A37170-001](#) Leg brace
- NS3 [03-1645-01](#) Screw for legs
- NS4 [16-1100-08](#) Line set tube end, discharge
- NS5 [16-1100-09](#) Line set tube end, liquid

## Service Parts

### Evaporator System, Hard Nugget (NH)

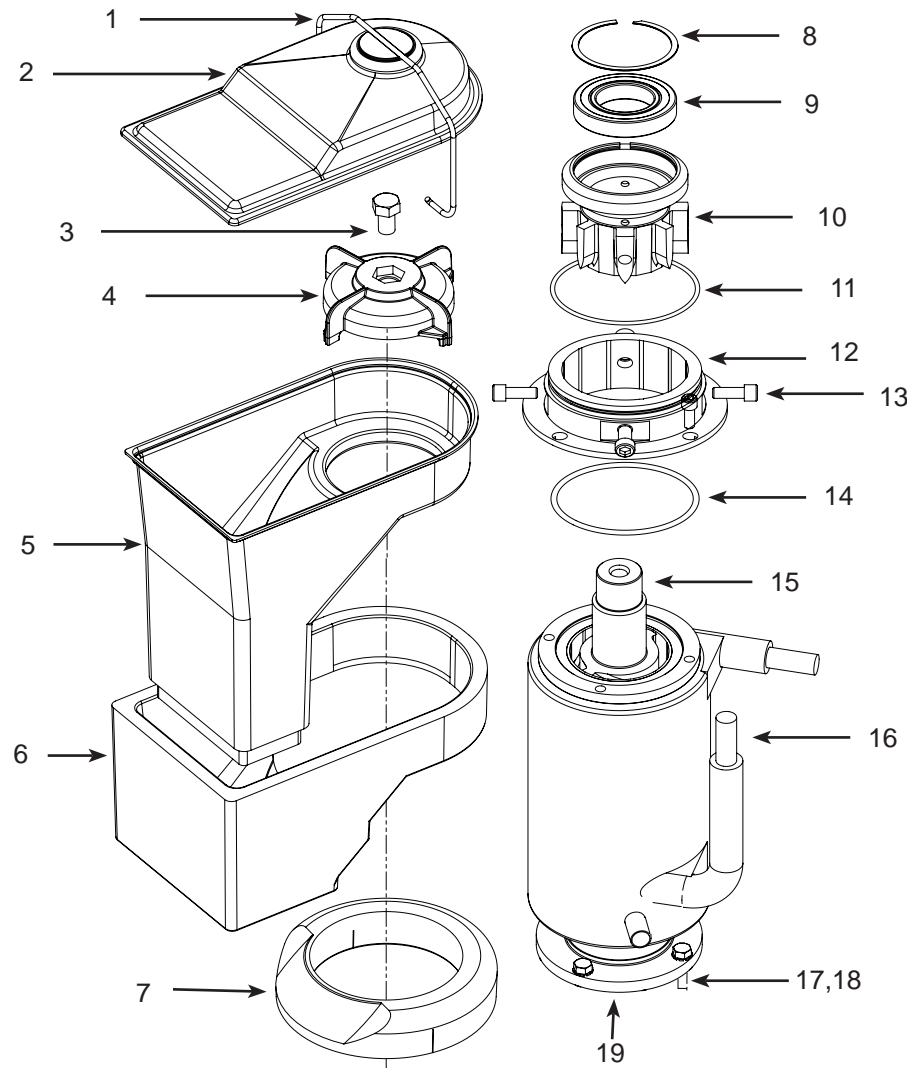

#### Hard Nugget:

NH0422, NH0622, NH0922, NH1322

Item Number	Part Number	Description
1	02-5074-01	Bail clamp
2	02-5073-01	Ice chute cover
3	03-1405-52	Hex head cap screw, 1/2"-13
4	02-5071-02	Ice sweep
5	02-5072-02	Ice chute
6	02-5086-02	Ice chute insulation
7	13-0929-03	Insulation collar
8	02-5070-01	Retaining ring
9	02-5069-01	Top bearing
10	02-5050-01	Extruder
10a	A40991-023	Extruder/Bearing assembly kit (includes 8,9,10)
11	13-0617-52	O-ring
12	02-5049-01	Extruder adapter
13	03-1544-08	Allen head screw, 5/16-18x3/4"
14	13-0617-45	O-ring
15	02-5060-01	Auger- NH0422, NH0622
	02-5060-02	Auger- NH0922, NH1322
16	02-5061-21	Evaporator- NH0422, NH0622
	02-5061-22	Evaporator- NH0922, NH1322
17	03-1417-13	Lock washer 5/16"
18	03-1405-38	Hex head cap screw, 5/16-18x3/4"
19	A40174-001	Evaporator/Gearbox adapter assembly
19a	02-4843-23	Lower Bearing
NS1	02-0929-23	Water Seal
NS2	A40991-033	Conversion to hard nugget (includes 4,5,6,7,8,9,10,11,12,13,14)

### Evaporator System, Soft Nugget (NS)

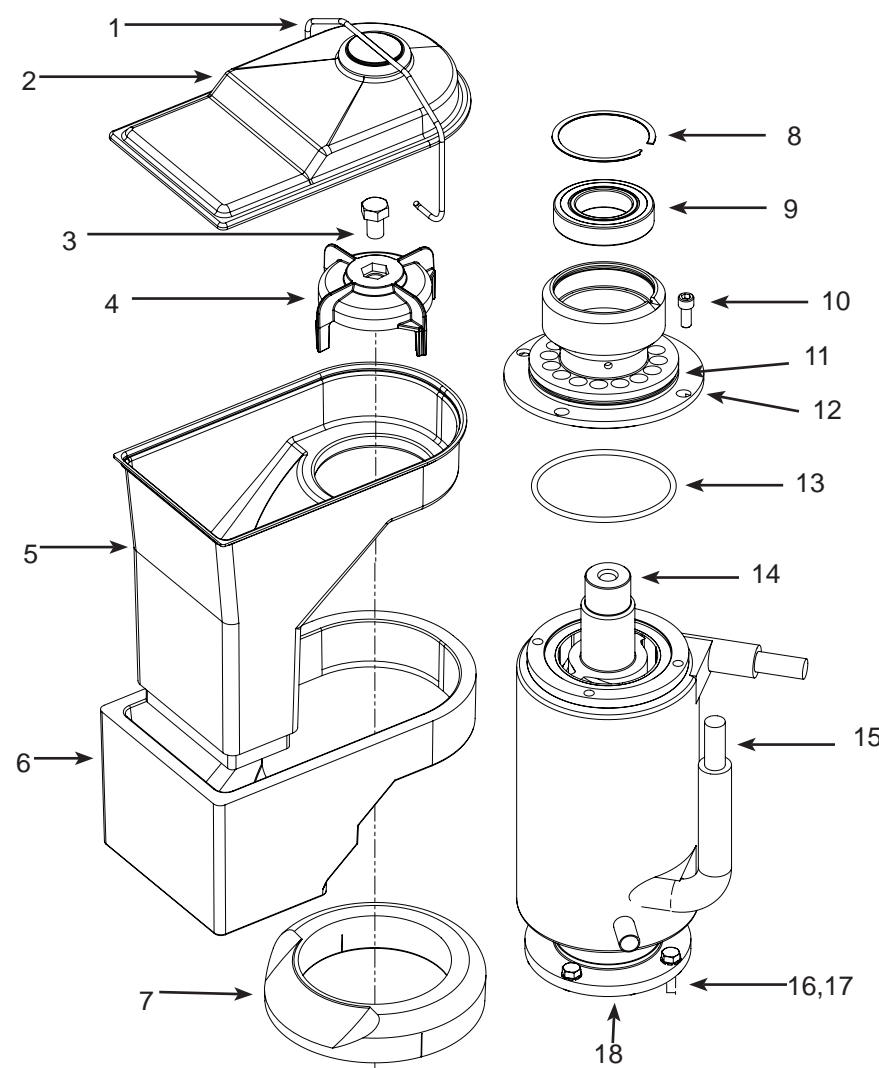

#### Soft Nugget:

NS0422, NS0622, NS0922, NS1322

Item Number	Part Number	Description
1	02-5074-01	Bail clamp
2	02-5073-01	Ice chute cover
3	03-1405-52	Hex head cap screw, 1/2"-13
4	02-5071-01	Ice sweep
5	02-5072-01	Ice chute
6	02-5086-01	Ice chute insulation
7	13-0929-02	Insulation collar
8	02-5070-01	Retaining ring
9	02-5069-01	Top bearing
10	03-1544-08	Allen head screw, 5/16-18x3/4"
11	13-0617-52	O-ring
12	02-5067-01	Extruder
12a	A40991-021	Extruder/Bearing assembly kit (includes 8,9,11,12,13)
13	13-0617-45	O-ring
14	02-5060-01	Auger- NS0422, NS0622
	02-5060-02	Auger- NS0922, NS1322
15	02-5061-21	Evaporator- NS0422, NS0622
	02-5061-22	Evaporator- NS0922, NS1322
16	03-1417-13	Lock washer 5/16"
17	03-1405-38	Hex head cap screw, 5/16-18x3/4"
18	A40174-001	Evaporator/Gearbox adapter assembly
18a	02-4843-23	Lower Bearing
NS1	02-0929-23	Water Seal
NS2	A40991-031	Conversion to soft nugget kit (includes 4,5,6,7,8,9,11,12,13)

Short - NH0422, NS0422, FS0522, NH0622, NS0622, FS0822

Tall - NH0922, NS0922, FS1222, NH1322, NS1322, FS1522

### Evaporator System, Flaker (FS)

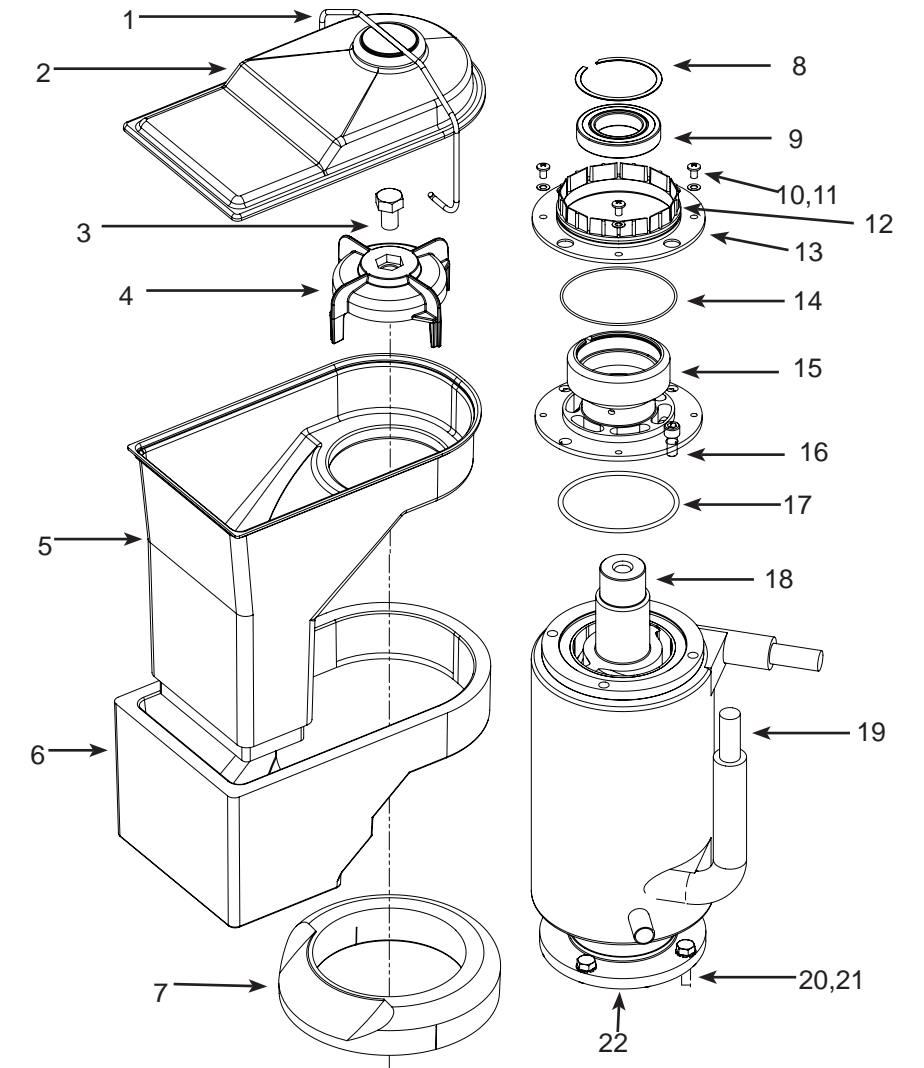

#### Flaker

FS0522, FS0822, FS1222, FS1522

Item Number	Part Number	Description
1	02-5074-01	Bail clamp
2	02-5073-01	Ice chute cover
3	03-1405-52	Hex head cap screw, 1/2"-13
4	02-5071-01	Ice sweep
5	02-5072-01	Ice chute
6	02-5086-01	Ice chute insulation
7	13-0929-01	Insulation collar
8	02-5070-01	Retaining ring
9	02-5069-01	Top bearing
10	03-1408-36	Washer
11	03-1403-27	Screw #10-24
12	13-0617-52	O-ring
13	02-2916-01	Slotted collar
14	13-0617-49	O-ring
15	02-5068-01	Extruder
15a	A40991-022	Extruder/Bearing Assembly Kit (includes 8,9,15,17)
16	03-1544-08	Allen head screw, 5/16-18x3/4"
17	13-0617-45	O-ring
18	02-5060-01	Auger- FS0522, FS0822
	02-5060-02	Auger- FS1222, FS1522
19	02-5061-21	Evaporator- FS0522, FS0822
	02-5061-22	Evaporator- FS1222, FS1522
20	03-1417-13	Lock washer 5/16"
21	03-1405-38	Hex head cap screw, 5/16-18x3/4"
22	A40174-001	Evaporator/Gearbox adapter assembly
22a	02-4843-23	Lower Bearing
NS1	02-0929-23	Water Seal
NS2	A40991-032	Conversion to flaker kit (includes 4,5,6,7,8,9,10,11,12,13,14,15,17)

## Service Parts

### Gear Reducer and Motor

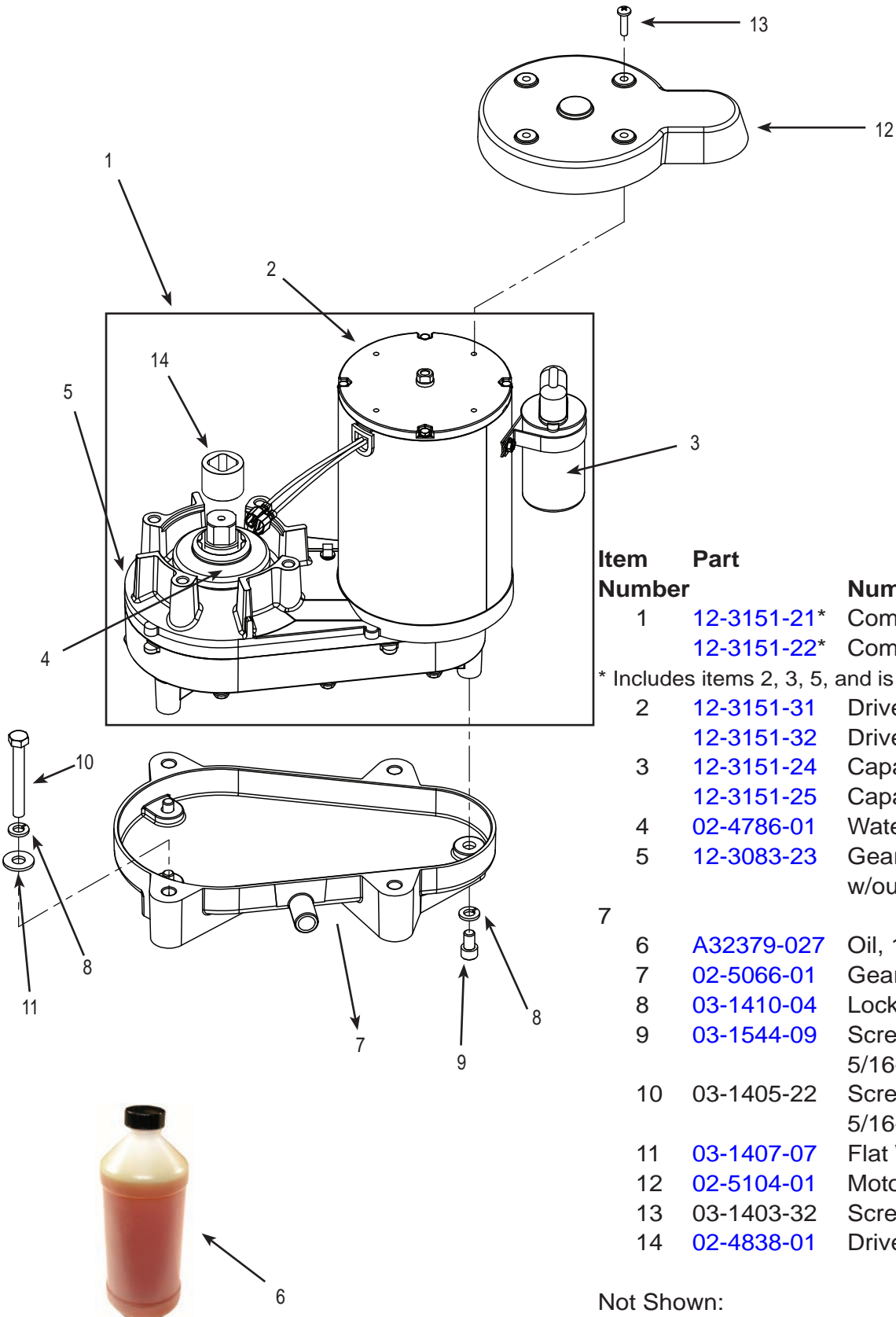

Item Number	Part	Number	Description
1	12-3151-21*		Complete assy 115V
	12-3151-22*		Complete assy 208-230V
* Includes items 2, 3, 5, and is charged with gear oil.			
2	12-3151-31		Drive motor, 115V
	12-3151-32		Drive Motor, 208-230V
3	12-3151-24		Capacitor kit, 115V
	12-3151-25		Capacitor kit, 208-230V
4	02-4786-01		Water Shed
5	12-3083-23		Gearbox kit, assembled w/out motor, includes item
6	A32379-027		Oil, 1 Container
7	02-5066-01		Gearbox drip pan
8	03-1410-04		Lock washer 5/16"
9	03-1544-09		Screw, socket head cap, 5/16-18 x 1-1/2"
10	03-1405-22		Screw, hex Cap, 5/16-18 x 1-1/2"
11	03-1407-07		Flat Washer 5/16"
12	02-5104-01		Motor Shield
13	03-1403-32		Screw, #10-24 x 3/4"
14	02-4838-01		Drive coupling

Not Shown:

15	12-3151-33	First Gear (Phenolic)
16	12-3151-34	Gasket

**Oil Charge is 14 Oz.**

## Service Parts

### Electrical & Control Box

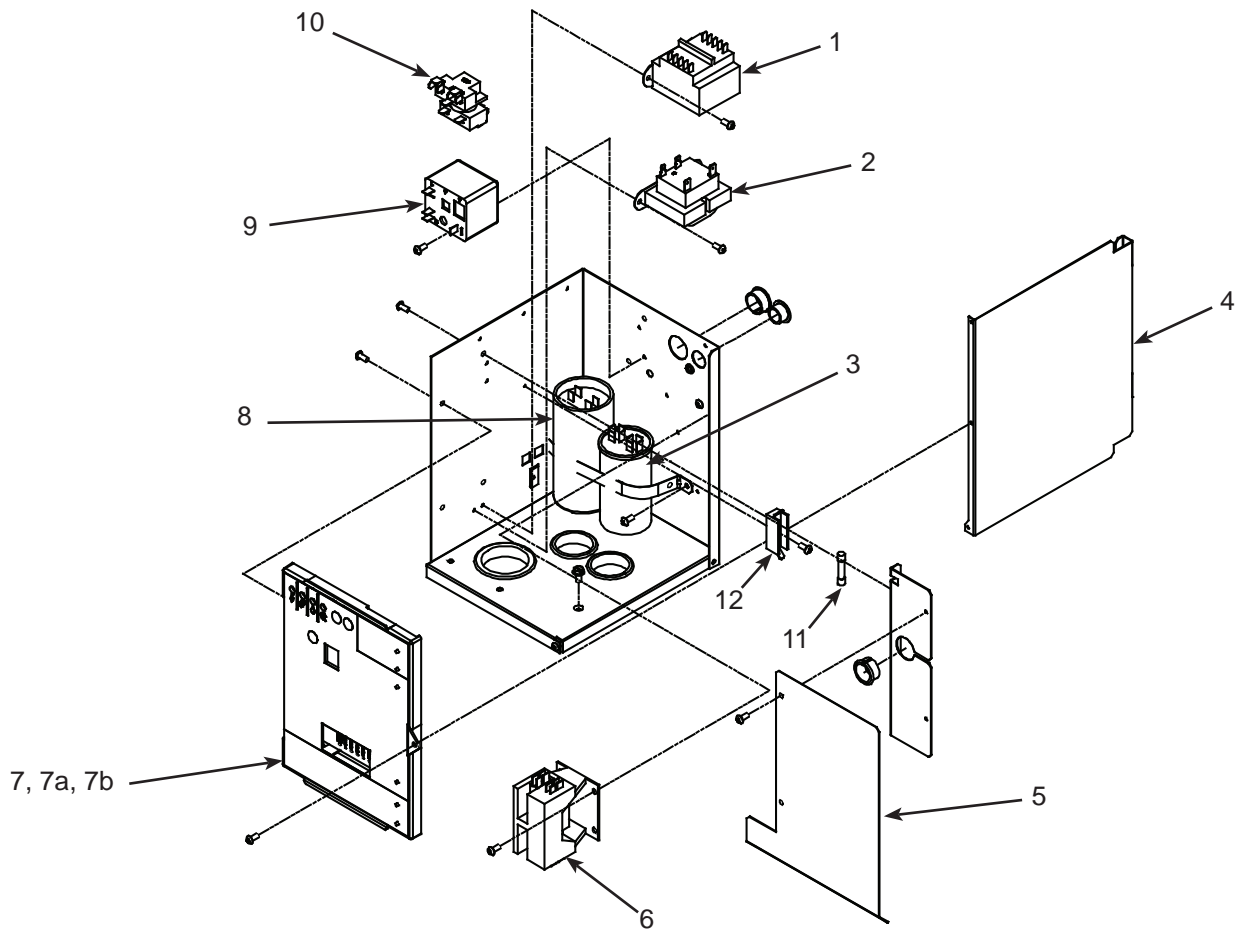

Item Number	Part Number	Description	Harnesses (not shown)
1	<a href="#">12-2639-01</a>	Transformer, 50 Hz	NS1 <a href="#">12-2976-01</a> Low voltage harness
2	<a href="#">12-2924-01</a>	Transformer, 115 v	NS2 <a href="#">12-3156-01</a> High voltage harness, AW
	<a href="#">12-2924-02</a>	Transformer, 208-230 60 Hz	NS3 <a href="#">12-3157-01</a> High voltage harness, Rem
3	see page 15	Run capacitor	NS4 <a href="#">12-2936-01</a> High voltage harness, dual fan motor
4	<a href="#">A39198-001</a>	Side cover	
5	<a href="#">A39216-001</a>	Shield	
6	<a href="#">12-2469-03</a>	Contactor, 115 volt	
	<a href="#">12-2469-02</a>	Contactor, 208-230 volt 60 Hz, single phase	
	<a href="#">12-2533-02</a>	Contactor, 3 phase	
7	<a href="#">11-0623-51</a>	Controller	
7a	<a href="#">02-4407-01</a>	Graphic overlay	
7b	<a href="#">02-4076-01</a>	Control box door	
8	see next page	Start capacitor	
9	see next page	Potential relay	
10	see next page	Start relay	
11	<a href="#">12-2686-01</a>	Fuse, 50 Hz only	
12	<a href="#">12-2687-01</a>	Fuse block, 50 Hz only	

## Service Parts

### Compressors

Model	Series	Electrical	Compressor	Overload	Relay	Start Cap	Run Cap
NH0422, NS0422, FS0522 -1	A	115/60/1	<a href="#">18-8929-21</a>	<a href="#">18-8929-23</a>	<a href="#">18-1903-64</a>	<a href="#">18-1901-63</a>	not used
NH0622, NS0622, FS0822 -1	A	115/60/1	<a href="#">18-8949-21</a>	Internal	<a href="#">18-1903-44</a>	<a href="#">18-1901-65</a>	<a href="#">18-1902-64</a>
NH0622, NH0622, FS0822 -32	A	208-230/60/1	<a href="#">18-8949-22</a>	<a href="#">18-8949-51</a>	<a href="#">18-1903-54</a>	<a href="#">18-1901-66</a>	<a href="#">18-1902-30</a>
NS0622 -6	A	230/50/1	<a href="#">18-8949-23</a>	<a href="#">18-8949-52</a>	<a href="#">18-1903-70</a>	<a href="#">18-1901-52</a>	<a href="#">18-1902-66</a>
NH0922, NS0922 -1	A	115/60/1	<a href="#">18-8955-21</a>	Internal	<a href="#">18-1903-78</a>	<a href="#">18-1901-69</a>	<a href="#">18-1902-71</a>
NH0922, NS0922, FS1222 -32	A	208-230/60/1	<a href="#">18-8955-22</a>	Internal	<a href="#">18-1903-54</a>	<a href="#">18-1901-20</a>	<a href="#">18-1902-67</a>
NH0922, NS0922, FS1222 -3	A	208-230/60/3	<a href="#">18-8955-23</a>	18-8955-53	-	-	-
NS0922, FS1222 -6	A	230/50/1	<a href="#">18-8990-26</a>	Internal	<a href="#">18-1903-71</a>	-	-
NH1322, NS1322, FS1522 -32	A	208-230/60/1	<a href="#">18-8749-22</a>	Internal	<a href="#">18-1903-46</a>	<a href="#">18-1901-48</a>	<a href="#">18-1902-70</a>
NH1322, NS1322, FS1522 -3	A	208-230/60/3	<a href="#">18-8749-24</a>	Internal	-	-	-

### Compressor Mounting Hardware

Model	Series	Bolt	Grommet	Washer	Sleeve
NH0422, NS0422, FS0522	A	<a href="#">03-1405-20</a>	<a href="#">18-4700-28</a>	<a href="#">03-1407-07</a>	<a href="#">18-0108-41</a>
NH0622, NS0622, FS0822	A	<a href="#">03-1405-20</a>	<a href="#">18-2200-28</a>	<a href="#">03-1407-07</a>	<a href="#">18-2200-27</a>
NH0922, NS0922, FS1222	A	<a href="#">03-1405-20</a>	<a href="#">18-2200-28</a>	<a href="#">03-1407-07</a>	<a href="#">18-2200-27</a>
NH1322, NS1322, FS1522	A	<a href="#">03-1405-20</a>	<a href="#">18-2300-27</a>	<a href="#">03-1407-07</a>	<a href="#">18-2300-26</a>

### Crankcase Heaters

Model	Series	Voltage	Heater
NH0622R-1, NS0622R-1, FS0822R-1	A	115	<a href="#">12-3043-01</a>
NH0922R-1, NS0922R-1	A	115	<a href="#">12-3043-01</a>
NH0922R-32, NS0922R-32, <a href="#">FS1222R-32</a>	A	230	<a href="#">12-3043-02</a>
FS1222R-3	A	230, 3 phase	<a href="#">12-3043-02</a>
NH1322R-32, NS1322R-32, FS1522R-32	A	230	<a href="#">12-3043-03</a>

# Service Parts

## Wiring Diagram - NH0422, NS0422, and FS0522 - Air/Water Single Phase (-1)

17-3705-01

**⚠** DASHED LINES INDICATE FIELD WIRING WHICH MUST BE INSTALLED IN ACCORDANCE WITH THE NATIONAL ELECTRICAL CODE AND ALL STATE AND LOCAL CODES.

USE COPPER CONDUCTORS ONLY

THIS UNIT MUST BE GROUNDED

EARTH GROUND  
SEE NAMEPLATE  
FOR SUPPLY VOLTAGE  
AND MAX FUSE SIZE

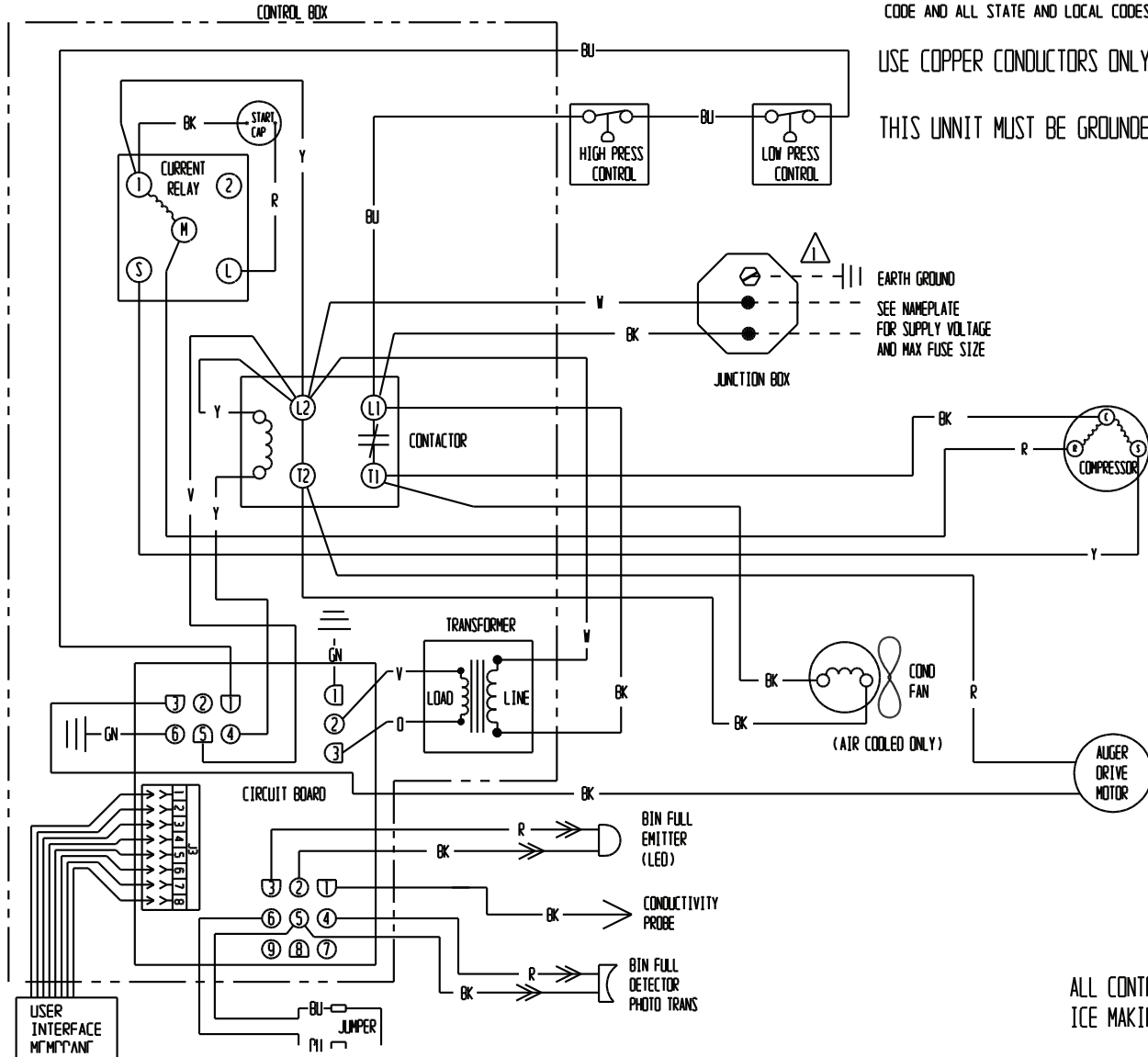

ALL CONTROLS SHOWN IN  
ICE MAKING MODE

## Service Parts

### Schematic Diagram - NH0422, NS0422, and FS0522 - Air/Water Single Phase (-1)

CAUTION:  
 MORE THAN ONE DISCONNECT MEANS MAY BE  
 REQUIRED TO DISCONNECT ALL POWER TO THIS UNIT.

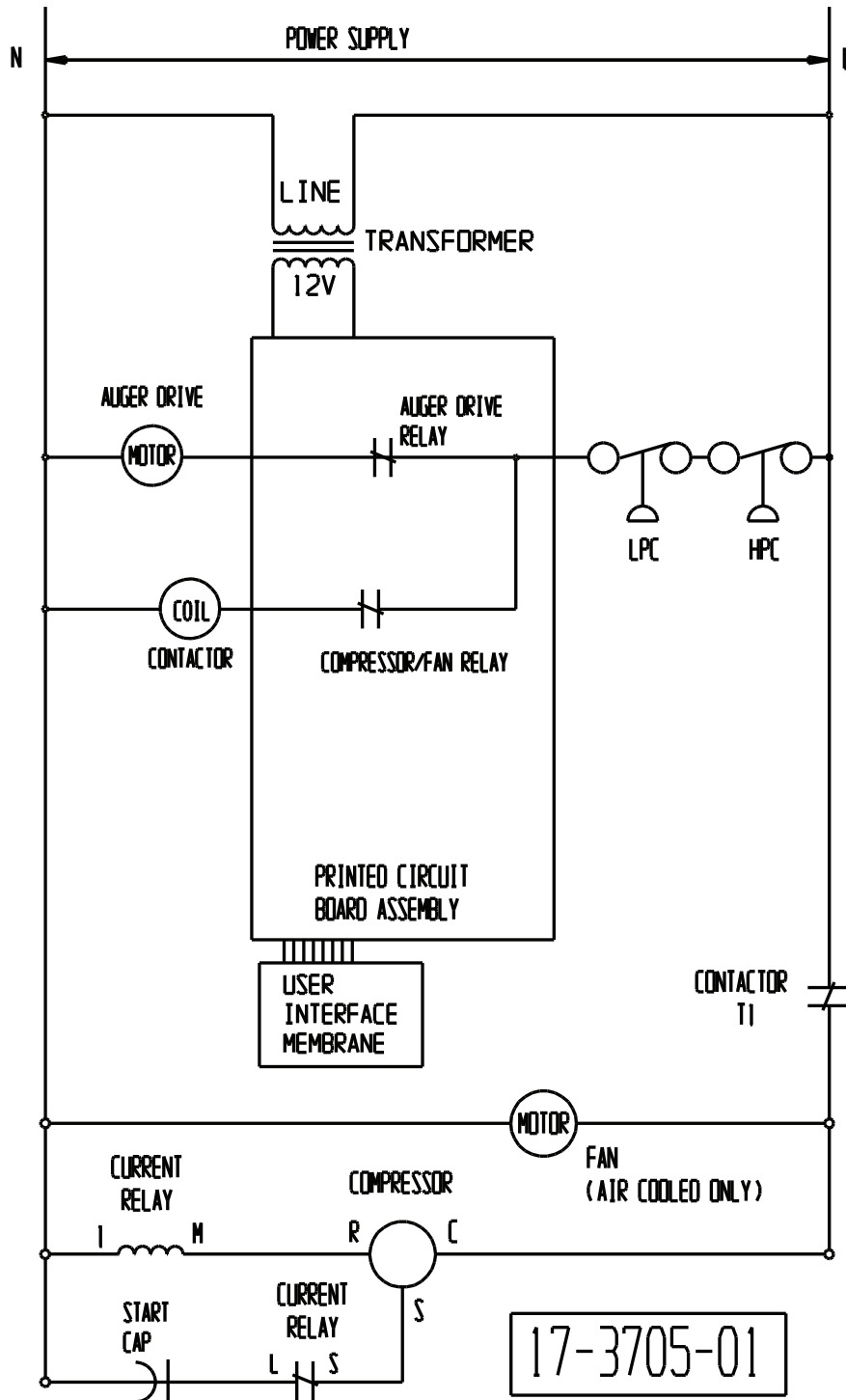

# Service Parts

Wiring Diagram - NH0622, NS0622, FS0822, NH0922, NS0922,  
FS1222, NH1322, NS1322, and FS1522 - Air/Water Single Phase (-1 and -32)

17-3700-01

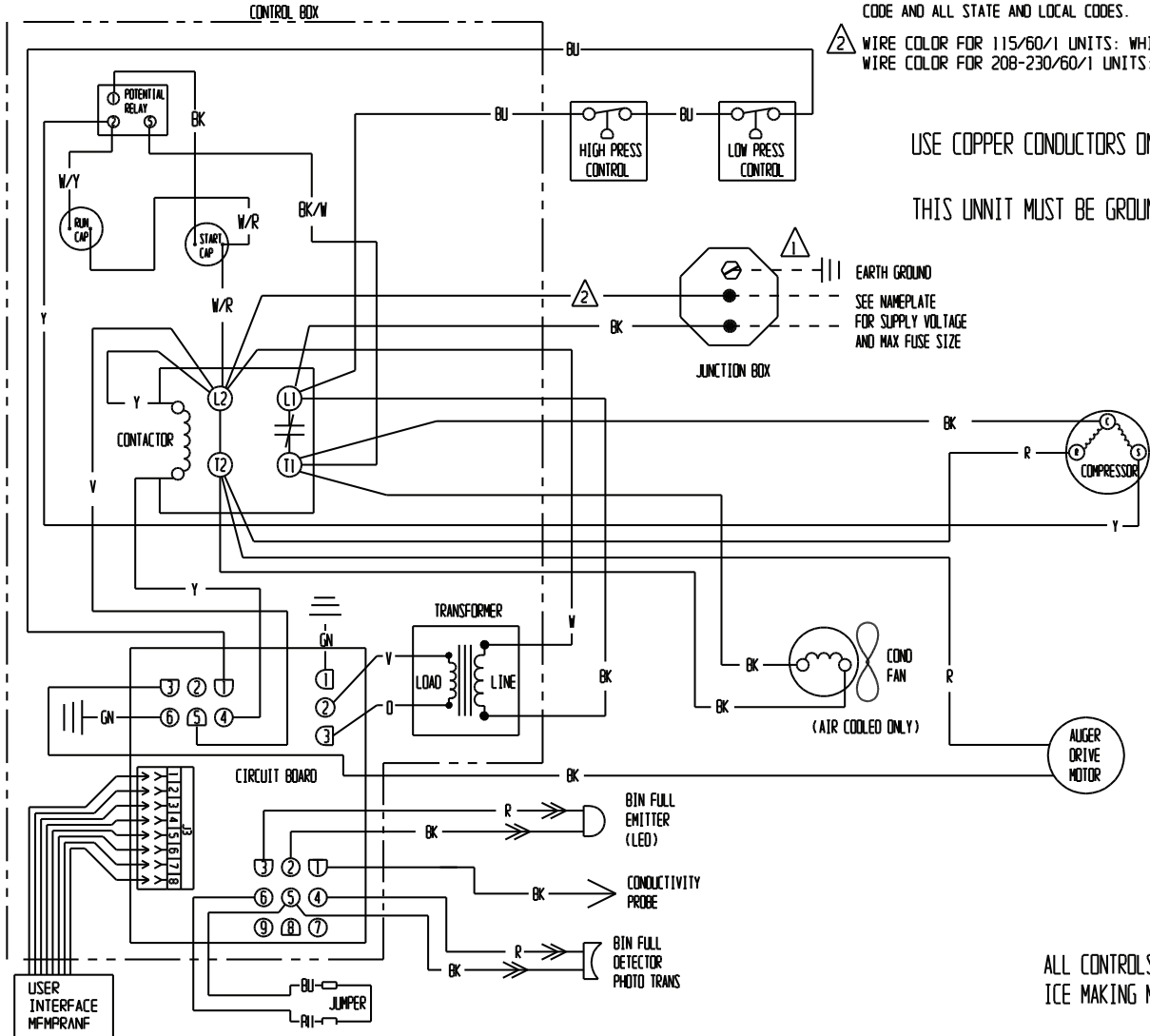

⚠ DASHED LINES INDICATE FIELD WIRING WHICH MUST BE INSTALLED IN ACCORDANCE WITH THE NATIONAL ELECTRICAL CODE AND ALL STATE AND LOCAL CODES.  
⚠ WIRE COLOR FOR 115/60/1 UNITS: WHITE  
WIRE COLOR FOR 208-230/60/1 UNITS: BLACK W/WHITE STRIPE

USE COPPER CONDUCTORS ONLY  
THIS UNIT MUST BE GROUNDED

EARTH GROUND  
SEE NAMEPLATE FOR SUPPLY VOLTAGE AND MAX FUSE SIZE

ALL CONTROLS SHOWN IN ICE MAKING MODE

# Service Parts

Schematic Diagram - NH0622, NS0622, FS0822, NH0922, NS0922, FS1222, NH1322, NS1322, and FS1522 - Air/Water Single Phase (-1 and -32)

CAUTION:  
 MORE THAN ONE DISCONNECT MEANS MAY BE  
 REQUIRED TO DISCONNECT ALL POWER TO THIS UNIT.

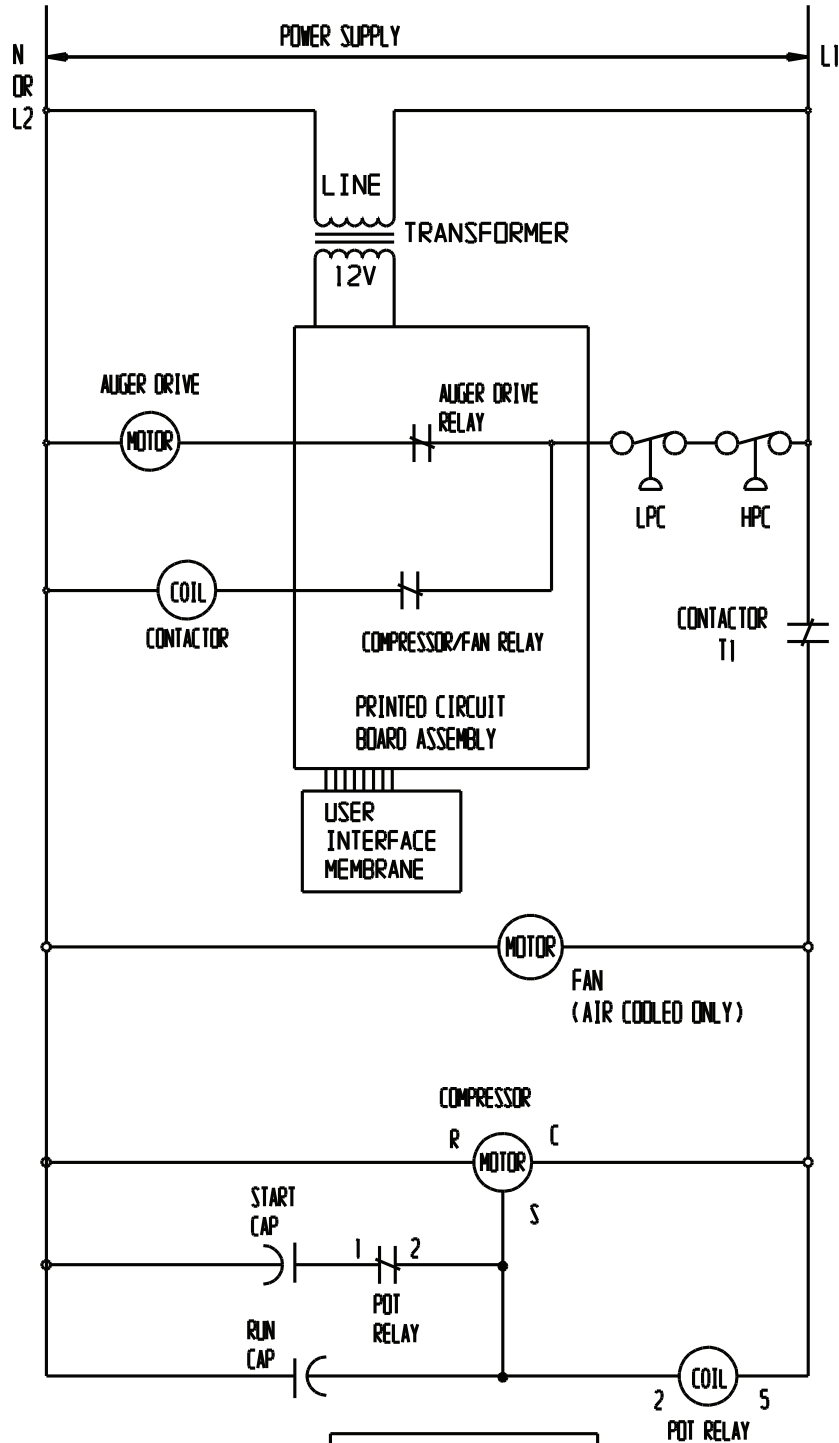

17-3700-01

# Service Parts

## Wiring Diagram - NS0922, FS1222, NH1322, NS1322 - Air/Water Three Phase (-3)

17-3703-01

⚠ DASHED LINES INDICATE FIELD WIRING WHICH MUST BE INSTALLED IN ACCORDANCE WITH THE NATIONAL ELECTRICAL CODE AND ALL STATE AND LOCAL CODES.

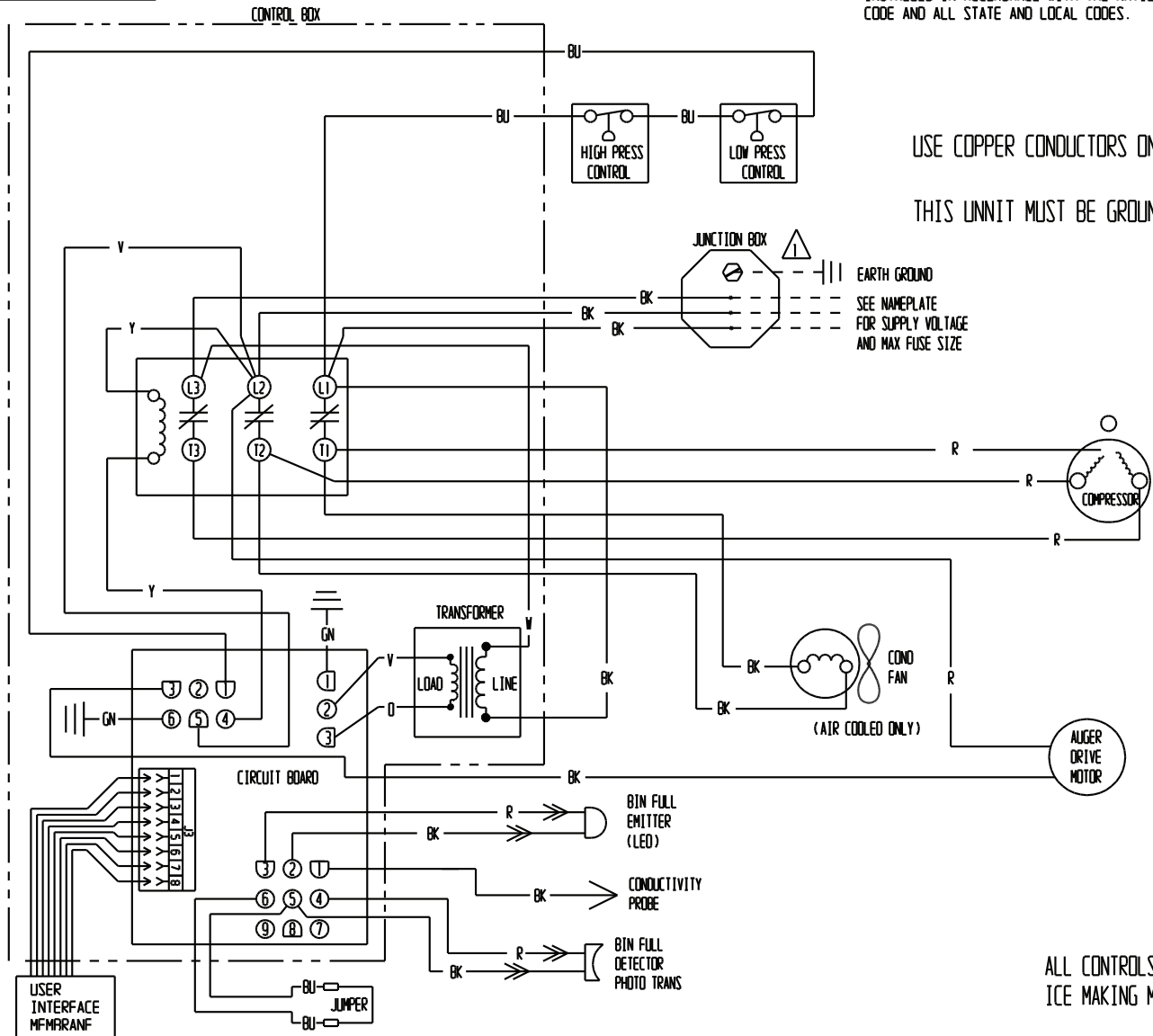

USE COPPER CONDUCTORS ONLY

THIS UNIT MUST BE GROUNDED

EARTH GROUND  
SEE NAMEPLATE  
FOR SUPPLY VOLTAGE  
AND MAX FUSE SIZE

ALL CONTROLS SHOWN IN  
ICE MAKING MODE

# Service Parts

## Schematic Diagram - NS0922, FS1222, NH1322, NS1322 - Air/Water Three Phase (-3)

CAUTION:  
 MORE THAN ONE DISCONNECT MEANS MAY BE  
 REQUIRED TO DISCONNECT ALL POWER TO THIS UNIT.

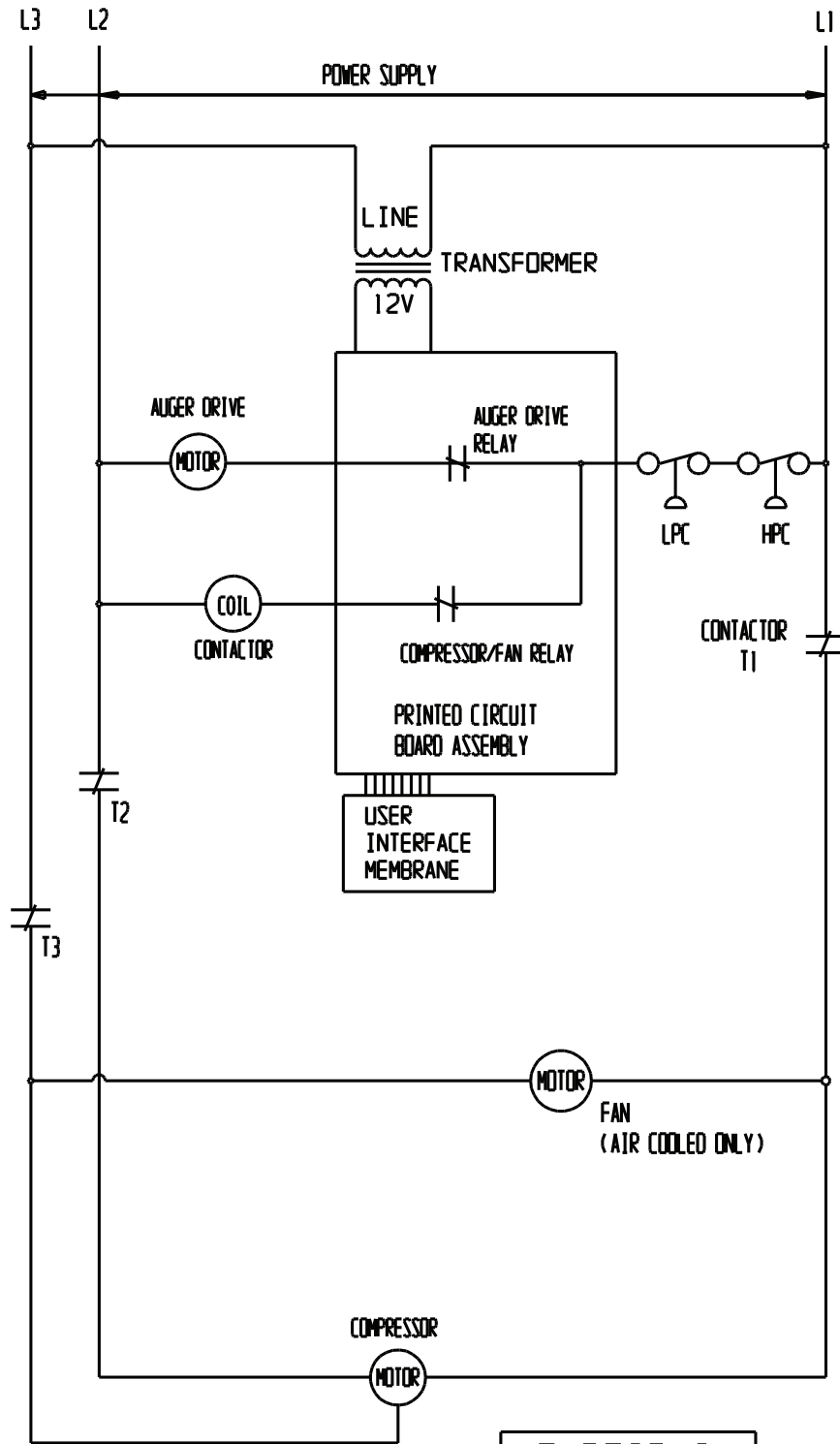

17-3703-01

# Service Parts

Wiring Diagram - NH0622, NS0622, FS0822, NH0922,  
NS0922, FS1222, NH1322, NS1322 - Remote Single Phase (-1 and -32)

17-3701-01

- ⚠ DASHED LINES INDICATE FIELD WIRING WHICH MUST BE INSTALLED IN ACCORDANCE WITH THE NATIONAL ELECTRICAL CODE AND ALL STATE AND LOCAL CODES.
- ⚠ WIRE COLOR FOR 115/60/1 UNITS: WHITE  
WIRE COLOR FOR 208-230/60/1 UNITS: BLACK W/WHITE STRIPE

USE COPPER CONDUCTORS ONLY  
THIS UNIT MUST BE GROUNDING

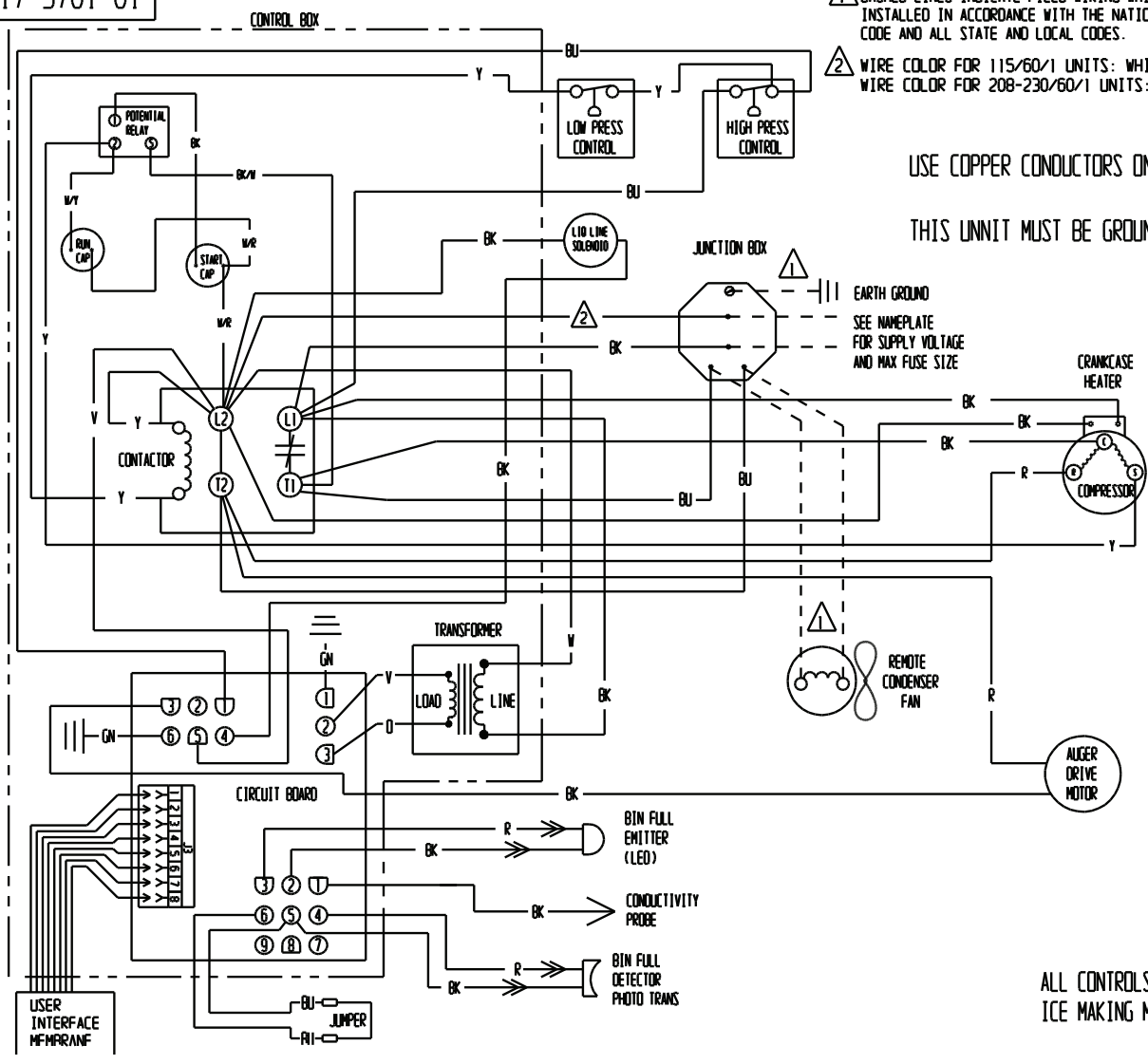

ALL CONTROLS SHOWN IN ICE MAKING MODE

# Service Parts

Schematic Diagram - NH0622, NS0622, FS0822, NH0922,  
NS0922, FS1222, NH1322, NS1322 - Remote Single Phase (-1 and -32)

CAUTION:  
MORE THAN ONE DISCONNECT MEANS MAY BE  
REQUIRED TO DISCONNECT ALL POWER TO THIS UNIT.

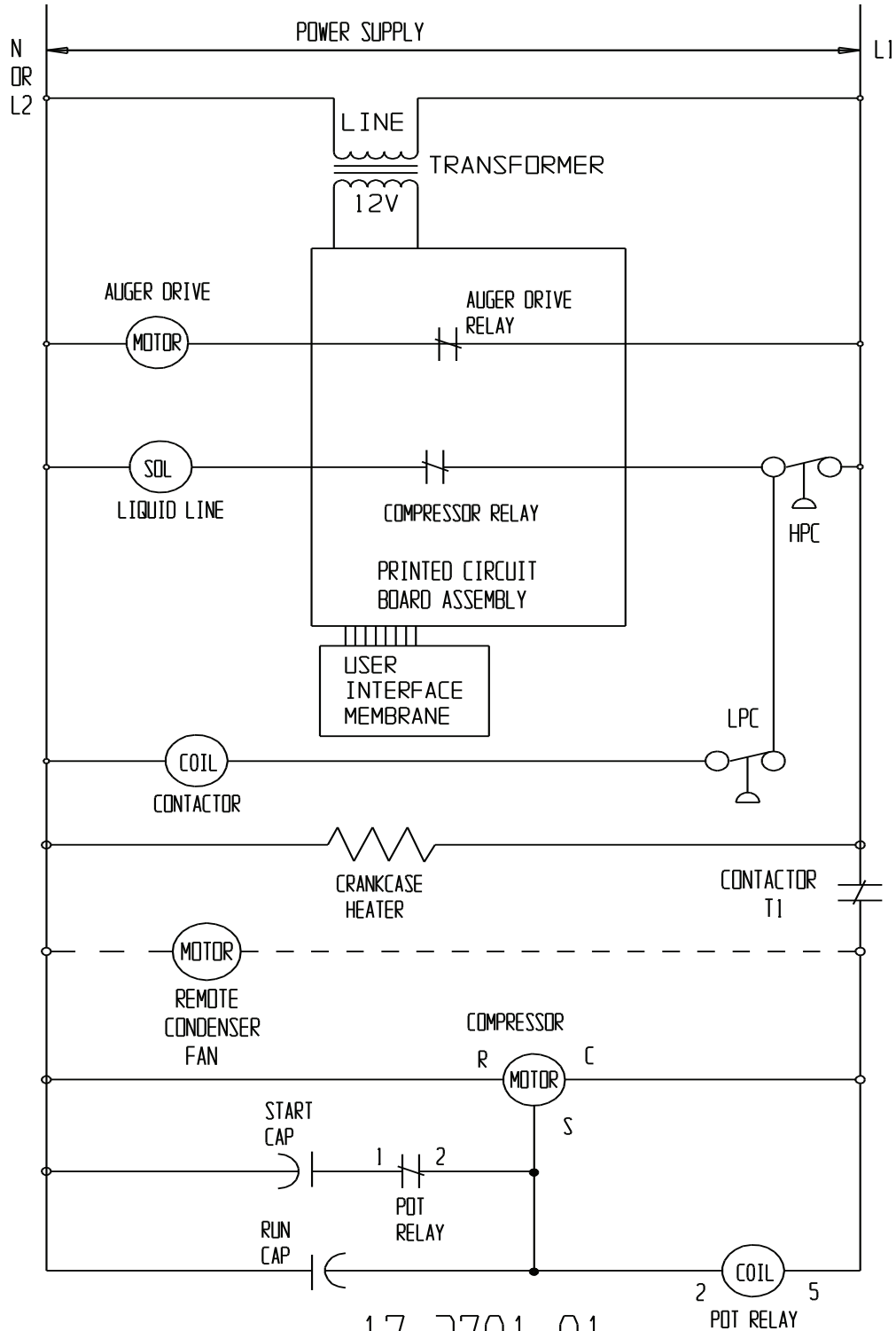

17-3701-01

# Service Parts

## Wiring Diagram - FS1222 - Remote Three Phase (-3)

17-3704-01

⚠ DASHED LINES INDICATE FIELD WIRING WHICH MUST BE INSTALLED IN ACCORDANCE WITH THE NATIONAL ELECTRICAL CODE AND ALL STATE AND LOCAL CODES.

USE COPPER CONDUCTORS ONLY

THIS UNIT MUST BE GROUNDED

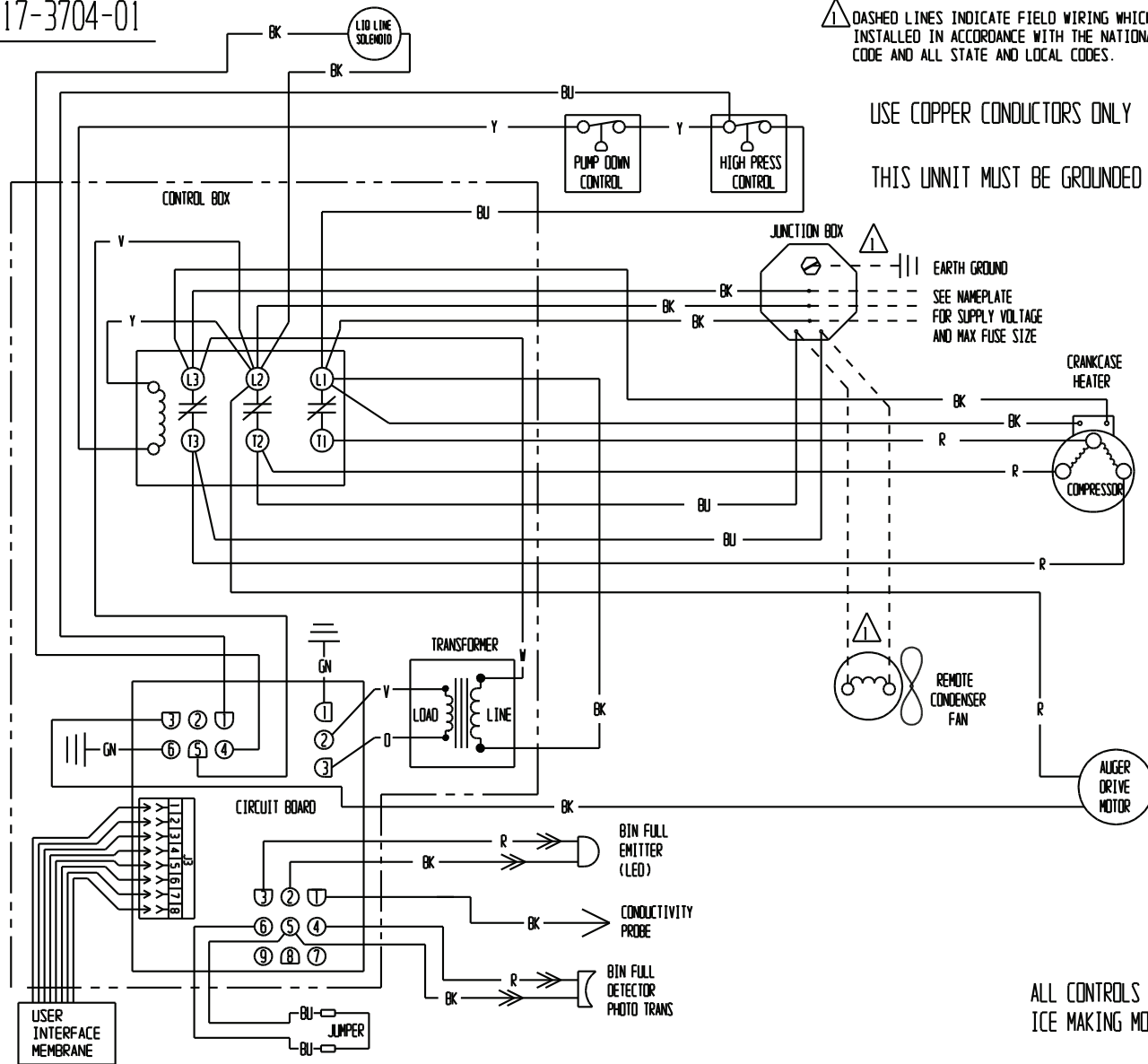

ALL CONTROLS SHOWN IN ICE MAKING MODE

# Service Parts

## Schematic Diagram - FS1222 - Remote Three Phase (-3)

CAUTION:  
 MORE THAN ONE DISCONNECT MEANS MAY BE  
 REQUIRED TO DISCONNECT ALL POWER TO THIS UNIT.

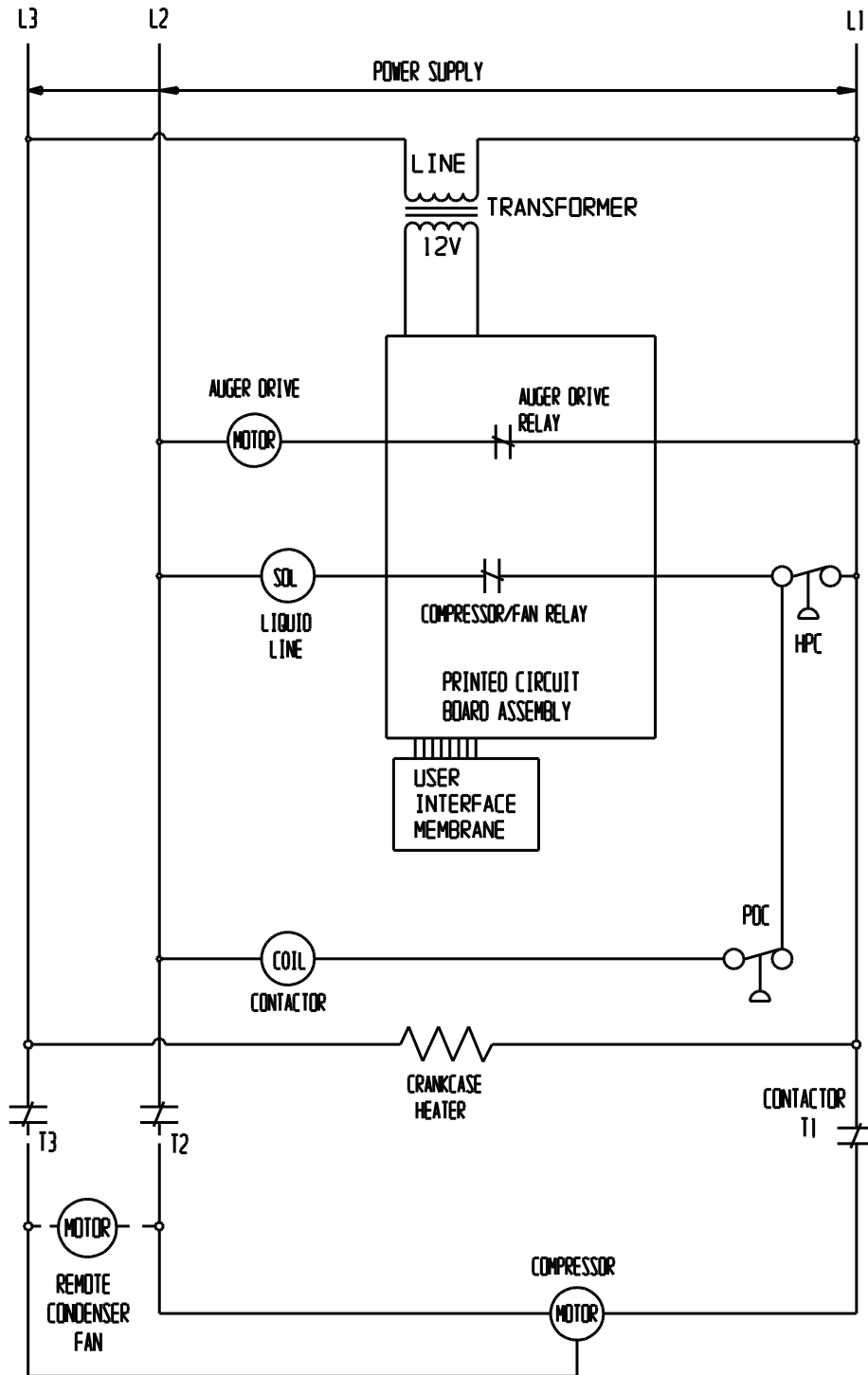

17-3704-01

# Service Parts

## Wiring Diagram - NS0622, NS0922, FS1222 - Air 50 Hz (-6)

17-3702-01

 DASHED LINES INDICATE FIELD WIRING WHICH MUST BE INSTALLED IN ACCORDANCE WITH THE NATIONAL ELECTRICAL CODE AND ALL STATE AND LOCAL CODES.

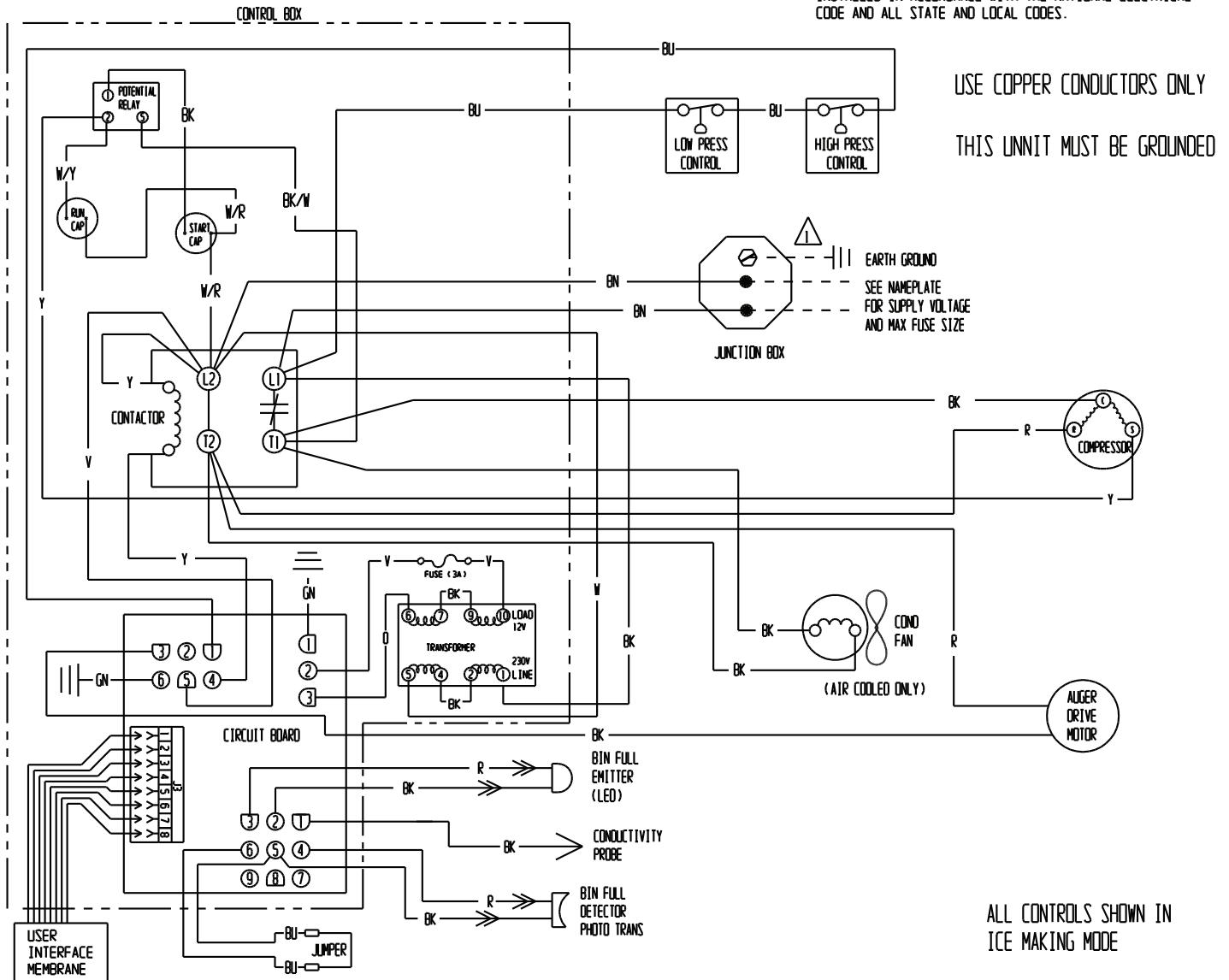

# Service Parts

## Schematic Diagram - NS0622, NS0922, FS1222 - Air 50 Hz (-6)

CAUTION:  
 MORE THAN ONE DISCONNECT MEANS MAY BE  
 REQUIRED TO DISCONNECT ALL POWER TO THIS UNIT.

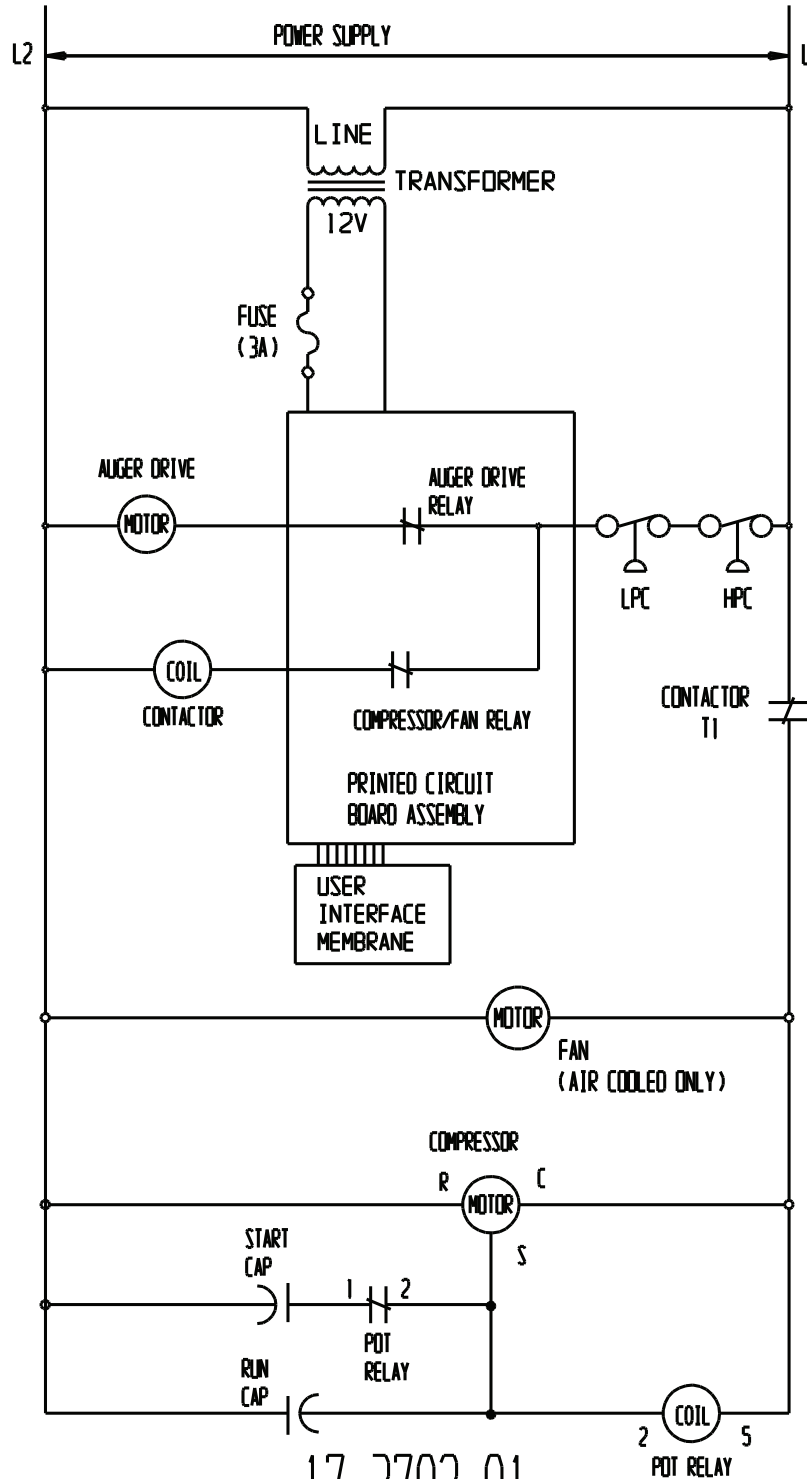

17-3702-01