

MC0330, MC0530, MC0630, MC0830, MC1030 Service Parts

Wiring Diagram MC0330, MC0530 or MC0630 Page 19

Schematic Diagram MC0330, MC0530 or MC0630 Page 20

Wiring Diagram MC0530R or MC0630R Page 21

Schematic Diagram MC0530R or MC0630R. Page 22

Wiring Diagram MC0830 MC1030 Air or Water -32 Page 23

Schematic Diagram MC0830 MC1030 Air or Water -32. Page 24

Wiring Diagram MC0830, MC1030 Air or Water -3 Page 25

Wiring Diagram MC0830, MC1030 Air or Water -3 Page 26

Wiring Diagram MC0830, MC1030 Remote -3. Page 27

Schematic Diagram MC0830, MC1030 Remote -3. Page 28

Wiring Diagram MC0830, MC1030 Remote -32 Page 29

Schematic Diagram MC0830, MC1030 Remote -32 Page 30

MC0330, MC0530, MC0630, MC0830, MC1030 Service Parts

Cabinet - MC0330, MC0530, MC0630

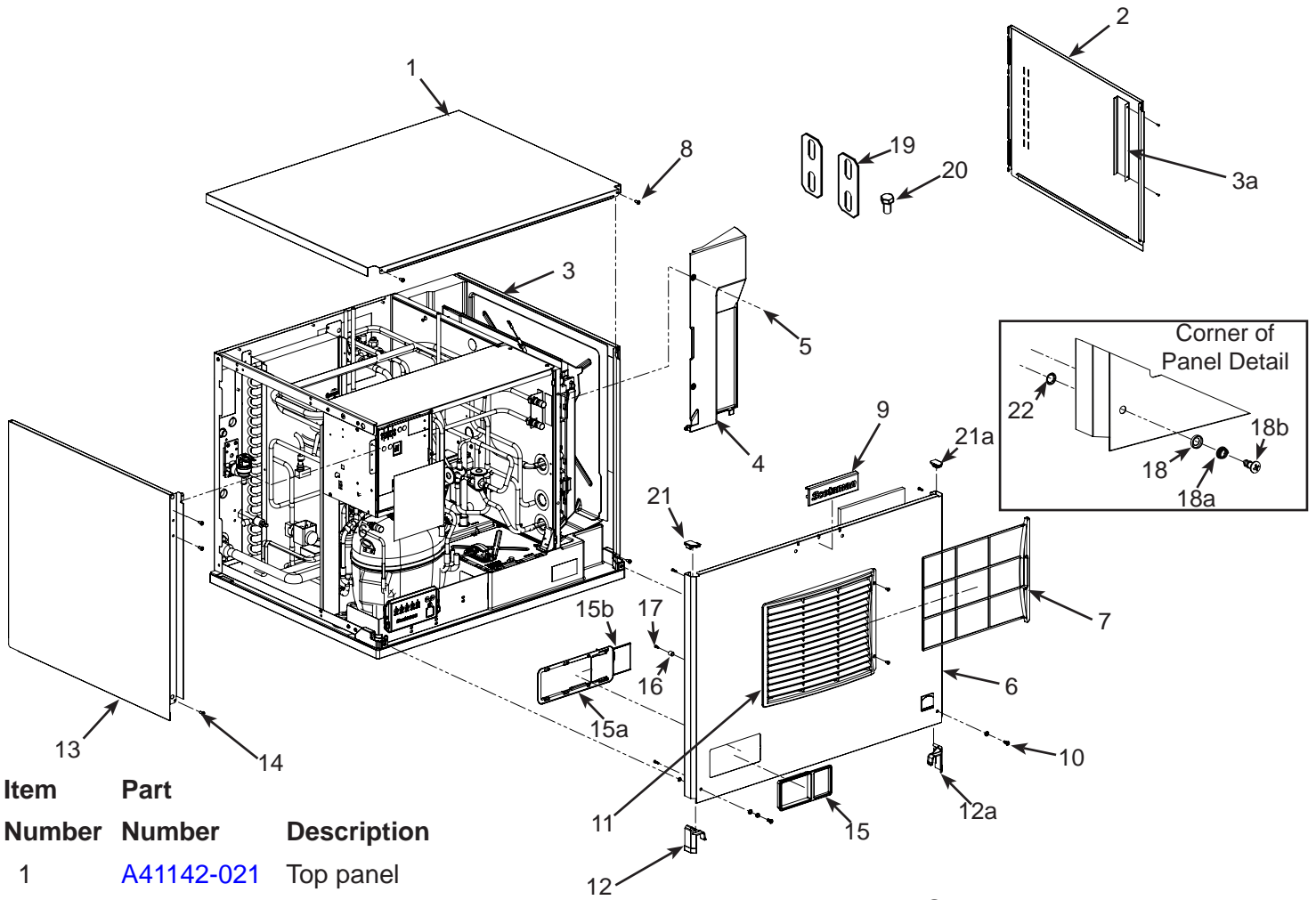

Item Number	Part Number	Description
1	A41142-021	Top panel
2	A41144-021	Right side panel
3	02-4336-01	Right side liner
3a	A40511-001	Liner bracket
4	02-4240-01	Evaporator cover
5	03-0727-05	Thumbscrew
6	A41141-021	Front panel, AC*
	A41141-022	Front panel, WC*
7	02-4212-03	Air filter
8	03-1419-26	Screw
9	02-5154-01	Emblem
10	03-1735-03	Screw
11	02-4224-03	Louvers
11A	03-1419-26	Screw
12	02-5141-01	Bottom left corner
12a	02-5142-02	Bottom right corner
13	A41143-021	Left side panel, air
	A41143-022	Left side panel, water
14	03-1404-10	Screw
15	02-5142-01	Bezel with standard door
15a	02-5143-01	Door, bezel
15b	02-5143-02	Door, bezel secure
16	02-4824-01	Spacer
17	03-1731-02	Screw
18	03-1731-04	Cupped washer
18a	03-1731-03	Spring
18b	03-3838-02	Screw
19	A30911-015	Machine straps
20	03-1405-15	Screw
21	02-5140-01	Top left corner
21a	02-5140-02	Top right corner
22	03-1731-01	Retainer

* Front panels are complete, including air filters and all trim, bezels, labels and screws.

MC0330, MC0530, MC0630, MC0830, MC1030 Service Parts

Cabinet - MC0830, MC1030

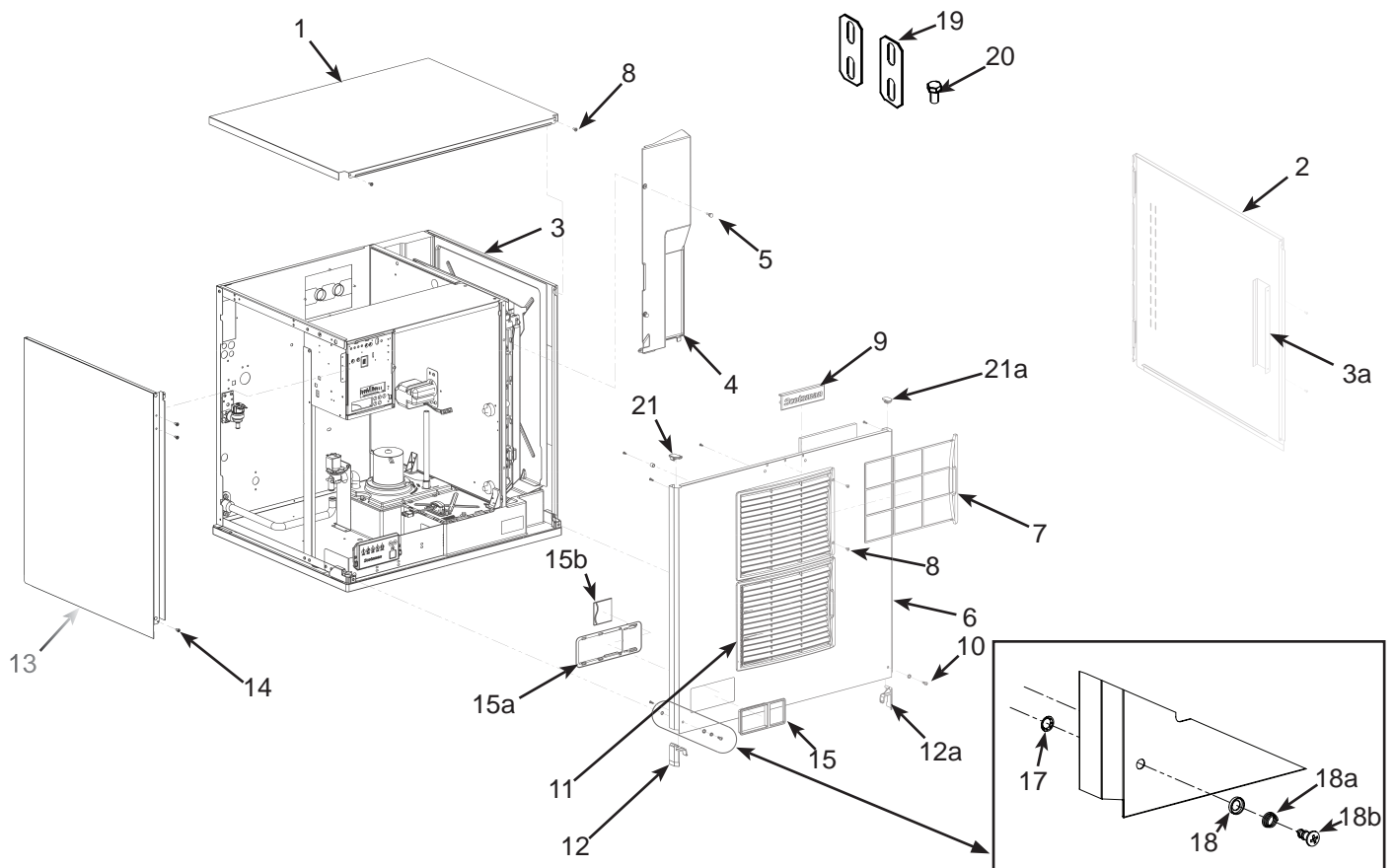

Item Number	Part Number	Description
1	A41142-021	Top panel
2	A41144-022	Right side panel
3	02-4336-02	Right side liner
3a	A40511-001	Liner bracket
4	02-4240-02	Evaporator cover
5	03-0727-05	Thumbscrew
6	A41141-023	Front panel, AC*
	A41141-024	Front panel, WC, RC*
7	02-4212-03	Air filter
8	03-1419-26	Screw
9	02-5154-01	Emblem
10	03-1735-03	Screw
11	02-4224-03	Louvers
11A	03-1419-26	Screw
12	02-5141-01	Bottom left corner
12a	02-5142-02	Bottom right corner
13	A41143-023	Left side panel, air
	A41143-024	Left side panel, water, remote
14	03-1404-10	Screw
15	02-5142-01	Bezel with standard door
15a	02-5143-01	Door, bezel
15b	02-5143-02	Door, bezel secure
16	02-4824-01	Spacer
17	03-1731-02	Cupped washer
18	03-1731-04	Cupped washer
18a	03-1731-03	Spring
18b	03-3838-02	Screw
19	A30911-015	Machine straps
20	03-1405-15	Screw
21	02-5140-01	Top left corner
21a	02-5140-02	Top right corner

* Front panels are complete, including air filters and all trim, bezels, labels and screws.

MC0330, MC0530, MC0630, MC0830, MC1030 Service Parts

Interior Parts

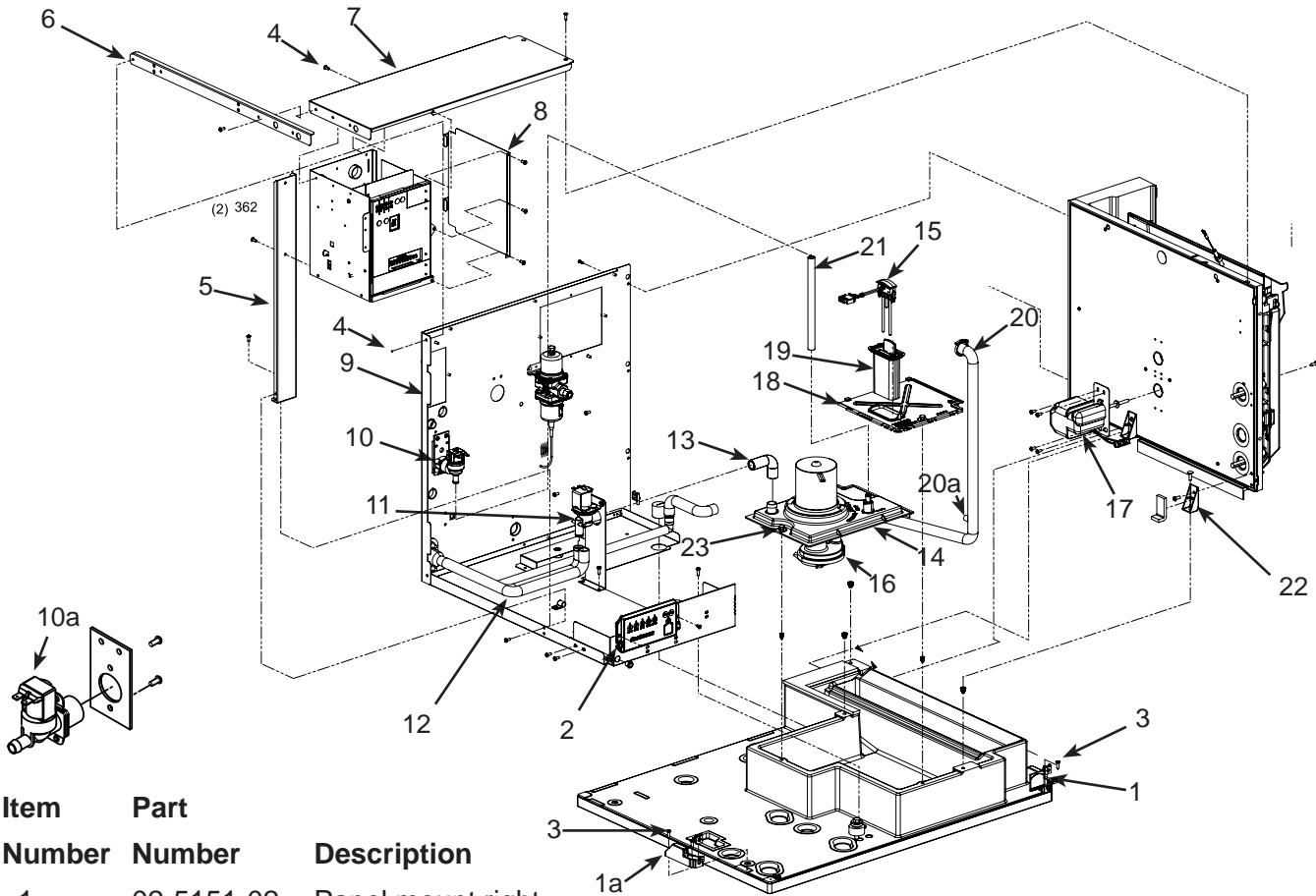

Item Number	Part Number	Description
1	02-5151-02	Panel mount right
1a	02-5151-01	Panel mount left
2	11-0622-21	Light & switch panel
3	03-1404-18	Screw
4	03-1531-01	Screw
5	A38607-001	Strut, 0330-630
	A38629-001	Strut, 0830, C1030
6	A40282-001	Left side channel
7	A40283-001	Control box top
8	A38537-001	Control box side
9		Back panel, see page 14-15
10	12-3124-01	Inlet water sol vlv, 115 volt
	12-3124-02	Inlet water sol vlv, 230 volt
	12-2912-01	Water valve rebuild kit
10a	11-0568-02	Inlet water sol vlv, CE mod
11	11-0564-01	Purge valve, 115 volt
	11-0564-02	Purge valve, 230 volt
12	A38860-002	Drain tube
13	A38860-001	Drain hose
14	02-4164-01	Water pump bracket
15	A41192-001	Water level sensor

16 see table Water pumps

Models	115 volt	208-230/60	50 Hz
0330, 0530	12-2919-21	12-2919-22	12-2919-26
0630	-	12-2919-22	12-2919-26
0830, 1030	-	12-2920-23	12-2920-25

17 see table Harvest assist mechanism

Models	115 volt	208-230 volt
0330, 0530	12-3060-21	12-3060-22
0630, 0830, 1030	-	12-3060-22

18 [02-4647-01](#) Sump cover, use/w item 19

19 [02-4646-01](#) WLS guard, use/w item 18

20 [02-4154-03](#) Pump hose, 0830-1030

[02-4154-02](#) Pump hose, 0530-0630

[02-4154-01](#) Pump hose, 0330

20a [11-0515-21](#) Temp sensor set

21 [13-0674-02](#) Fill hose order by ft

[15-0821-01](#) Fill hose, -6 CE models

22 [02-4152-01](#) Gusset

23 [03-0727-05](#) Thumbscrew

MC0330, MC0530, MC0630, MC0830, MC1030 Service Parts

Evaporator Compartment

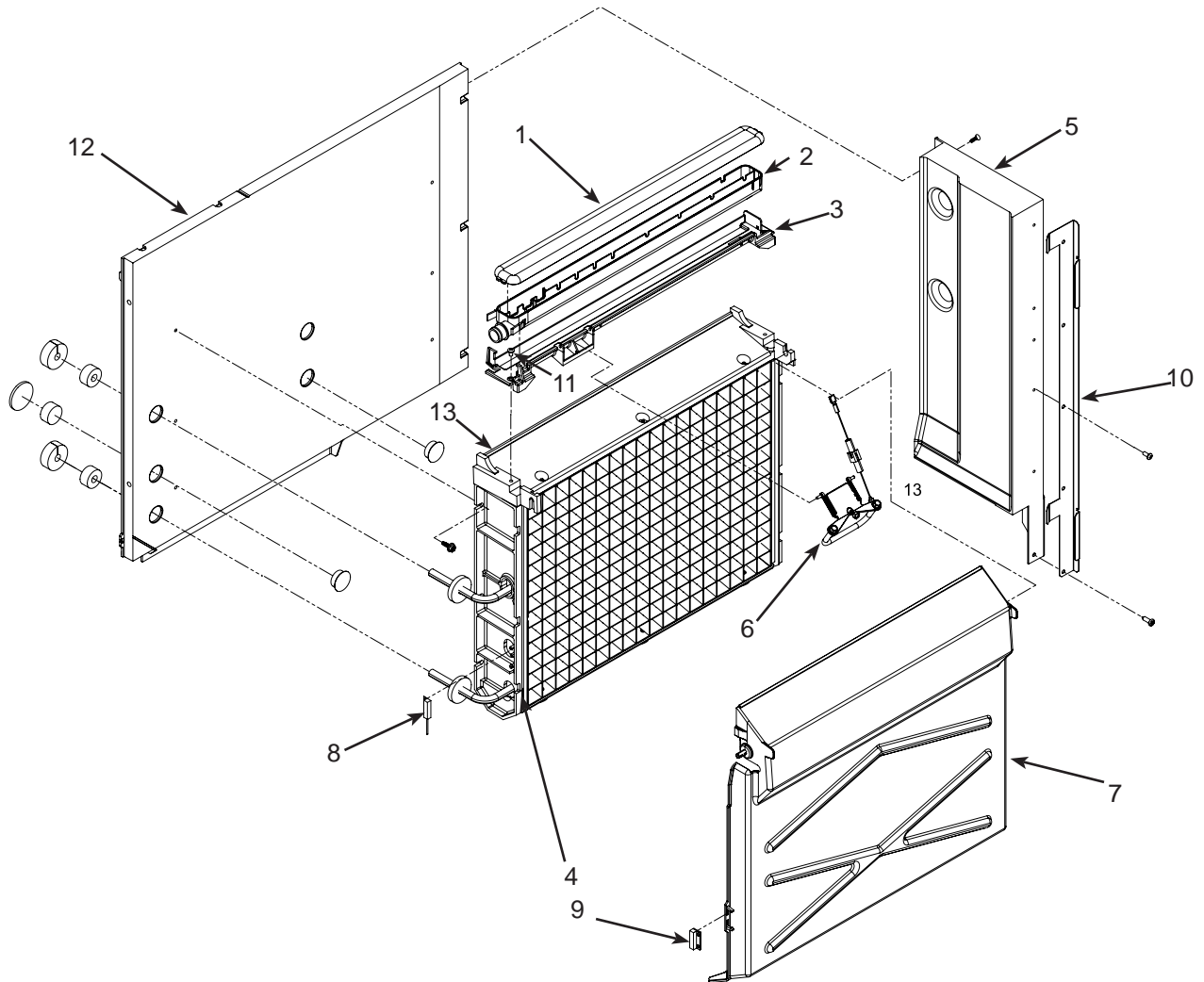

Item Number	Part Number	Description
1	02-4065-01	Water distributor cover
2	02-4064-01	Water distributor
3	02-4205-01	Mounting bracket
4	see table	Evaporator
5	A38596-001	Back wall, 0330, 0530, 0630
	A38598-001	Back wall, 0803, 1030
6	A41191-001	Ice thickness sensor
7	02-4100-31	Curtain, 0330
	02-4100-32	Curtain, 0530, 0630
7a	02-4611-21	Curtain, 0830, 1030
8	11-0563-01	Curtain switch
9	11-0563-02	Curtain switch magnet
10	A39560-001	Liner retainer, short*
	A39584-001	Liner retainer long*
11	03-1418-30	Mounting screw
12	13-0943-01	Gasket tape
13	02-4156-21	Spillway replacement kit

Note: Item 7 includes item 9, shipped loose.

Item 7a magnet is molded into curtain.

Short is 0330, 0530, 0630. Long is 0830 & 1030.

MC0330, MC0530, MC0630, MC0830, MC1030 Service Parts

Fan and Condenser Area MC0330 Air Cooled

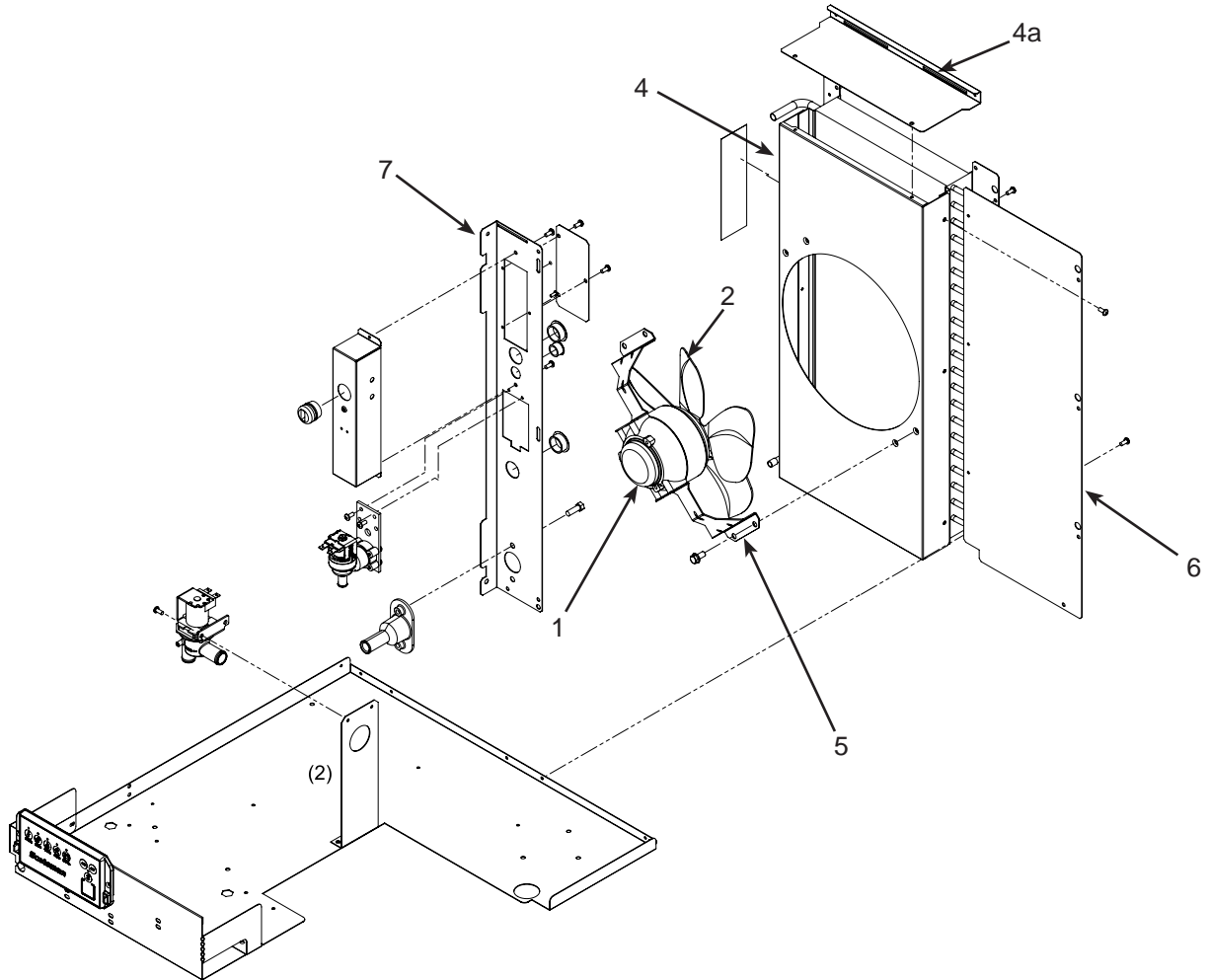

Item Number	Part Number	Description
1	12-1681-23	Fan motor, 0330, 115 volt
	12-1681-04	Fan motor, 0330, 230 volt
2	18-8836-01	Fan blade, 0330
3	02-3692-21	Drain adapter - also for WC and RC
4	A39350-001	Fan shroud, 0330
4a	A39593-001	Fan shroud top
5	A38480-001	Fan motor bracket, 0330
6	A39606-001	Back panel
7	A40418-001	Utility channel, (Air Cooled)

MC0330, MC0530, MC0630, MC0830, MC1030 Service Parts

Fan and Condenser Area MC0530 thru MC0830 Air Cooled

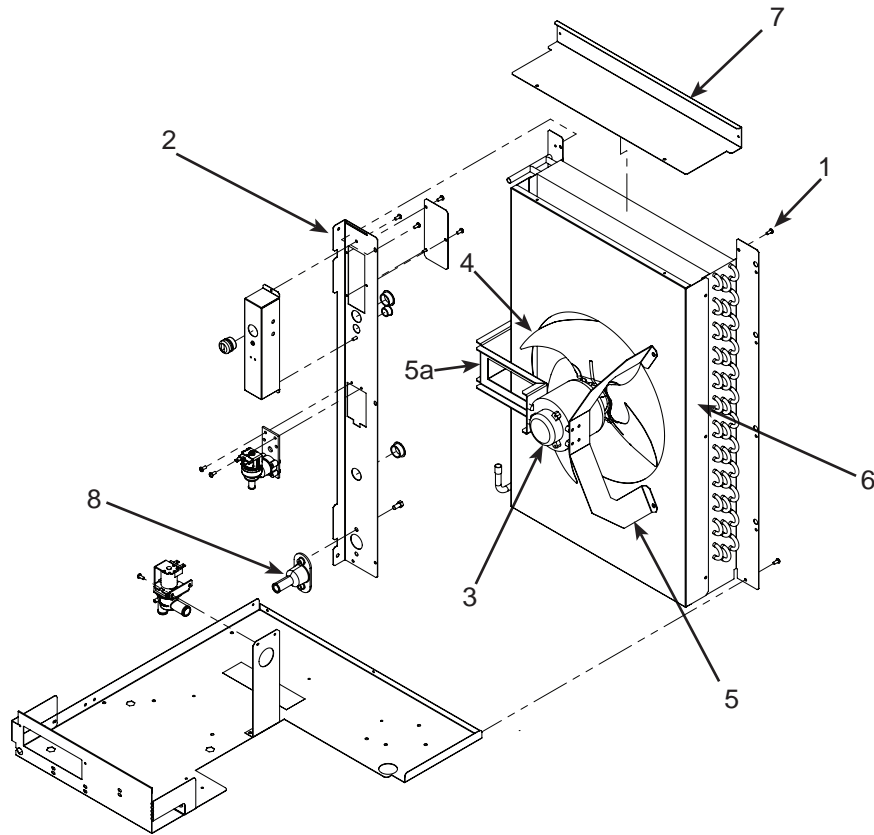

Item Number	Part Number	Description	Voltage/Hz	Fits Model	Fits series
1	03-1531-01	Screw		all	
2	A40420-001	Utility channel		0830-1030	
3	18-8926-01	Fan motor	115/60	0530-1	
	18-8927-01	Fan motor	208-230/60	0530, 0630, 0830-32,-3	
4	18-8882-01	Fan blade		0530, 0630, 0830	
5	A40156-001	Fan motor bracket, right		0530, 0630, 0830	*
5a	A40148-001	Fan motor bracket, left		0530, 0630, 0830,	*
6	A40146-001	Fan shroud		0530, 0630	*
	A40147-001	Fan shroud		0830	*
7	A39608-001	Shroud top		0530, 0630	
	A39601-001	Shroud top		0830	
8	02-3692-21	Drain adapter		all	

* Fan blade is .25" from end of shaft.

MC0330, MC0530, MC0630, MC0830, MC1030 Service Parts

Fan and Condenser Area MC1030 Air Cooled

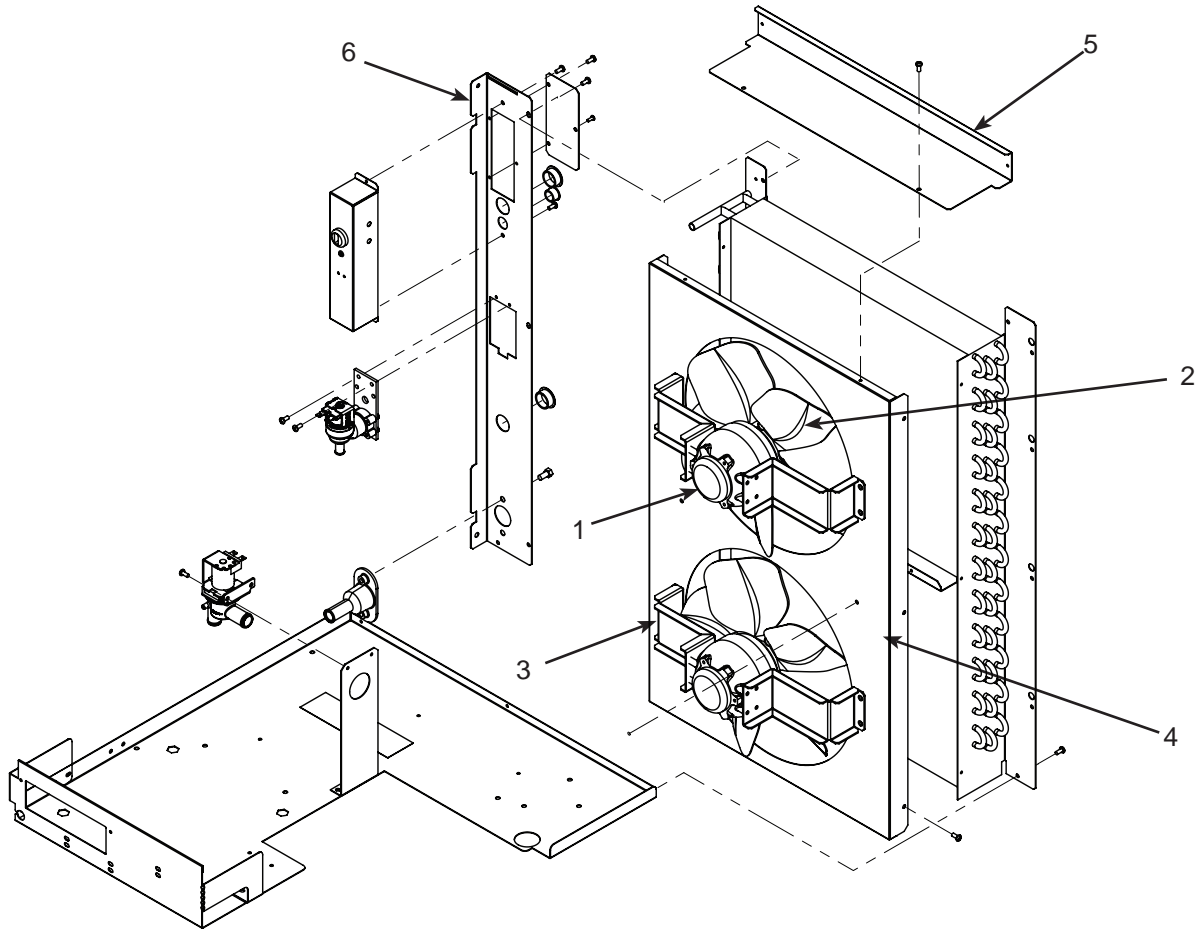

Item Number	Part Number	Description	Voltage/Hz	Fits Model	Fits series
1	18-8899-01	Fan motor	208-230/60	MC1030-32, -3	
	18-8899-06	Fan motor	230/50	MC1030-6	
2	18-8900-01	Fan blade	-	MC1030	
3	A38655-001	Fan motor bracket		MC1030	
4	A39609-001	Fan shroud		MC1030	
5	A39610-001	Fan shroud top		MC1030	
6	A40420-001	Utility channel		MC0830-1030	

MC0330, MC0530, MC0630, MC0830, MC1030 Service Parts

Air Cooled Refrigeration System

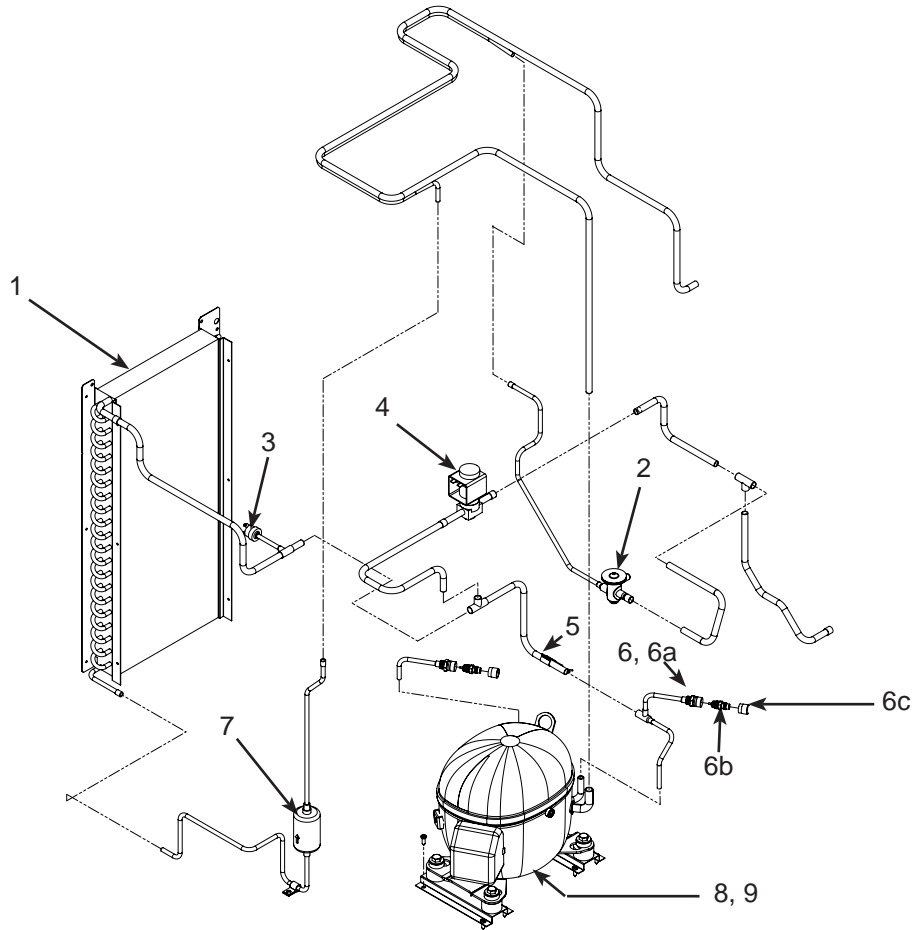

Item Number	Part Number	Description
1	18-8890-01	Condenser, AC, 0330
	18-8935-01	Cond, AC, 0530
	18-8936-01	Condenser, AC, 0630
	18-8895-01	Condenser, AC, 0830, 1030
2	16-1183-02	TXV, 0330
	16-1184-01	TXV, 0530
	16-1182-01	TXV, 0630
	16-1142-01	TXV, 0830, 1030
	19-0599-06	Insulation, TXV
3	11-0566-21	Fan cycle pressure sw.
4	11-0493-02	Hot gas valve, 115 volt
	12-2719-21	115 volt coil
	11-0493-01	Hot gas valve, 230 volt
	12-2719-22	230 volt coil
	12-2733-30	HGV rebuild kit
5	11-0515-21	Thermistor
6	16-1137-01	3/8" Valve body
6a	16-1138-01	1/4" Valve body
6b	16-1139-01	Core
6c	16-1140-01	Cap
7	02-3319-01	Dryer 0330 thru 0630
	02-3319-02	Dryer 0830 & 1030
8	see page 15	Compressors
9	see page 15	Compressor mounting hdw

MC0330, MC0530, MC0630, MC0830, MC1030 Service Parts

Water Cooled Refrigeration System MC0330 thru MC0830

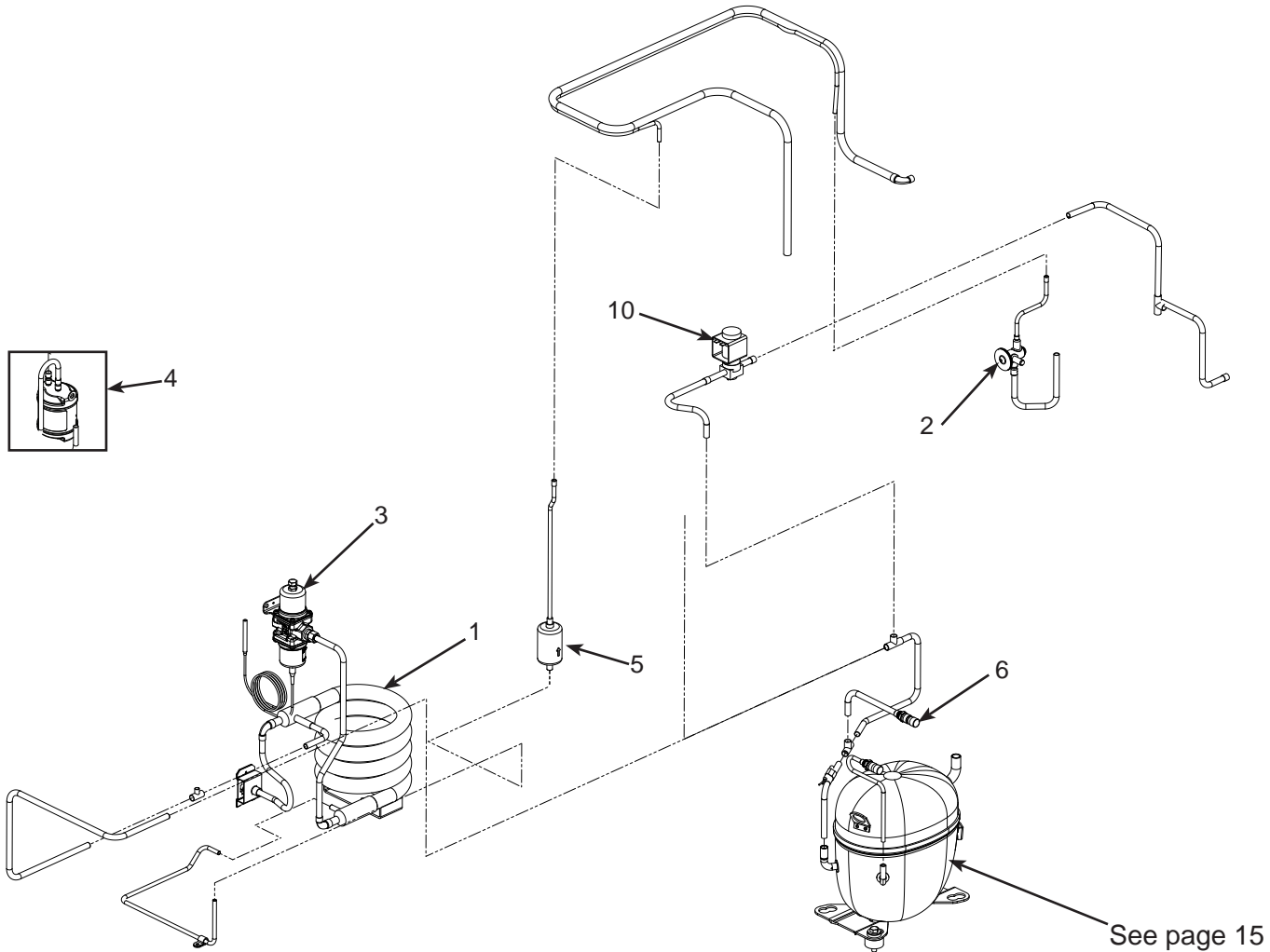

Item Number	Part Number	Description
1	18-8871-21	Condenser, WC, 0330, 0530, 0630, 0830
2	16-1184-01	TXV, 0530
	16-1182-01	TXV, 0630
	16-1183-02	TXV, 0330
	16-1142-01	TXV, 0830
	19-0599-06	Insulation TXV
3	11-0608-21	Water regulating valve
4	16-0840-01	MC0830 receiver
5	02-3319-01	Dryer, 0330 thru 0630
	02-3319-02	Dryer, 0830
6	16-1137-01	Valve body 3/8"
6a	16-1138-01	Valve body 1/4"
	16-1139-01	Core
	16-1140-01	Cap
10	11-0501-21	High pressure cut out MC0830
11	11-0493-02	Hot gas valve, 115 volt
	11-0493-01	Hot gas valve, 230 volt
	12-2719-22	230 volt coil
	12-2733-30	HGV rebuild kit

MC0330, MC0530, MC0630, MC0830, MC1030 Service Parts

Water Cooled Refrigeration System MC1030

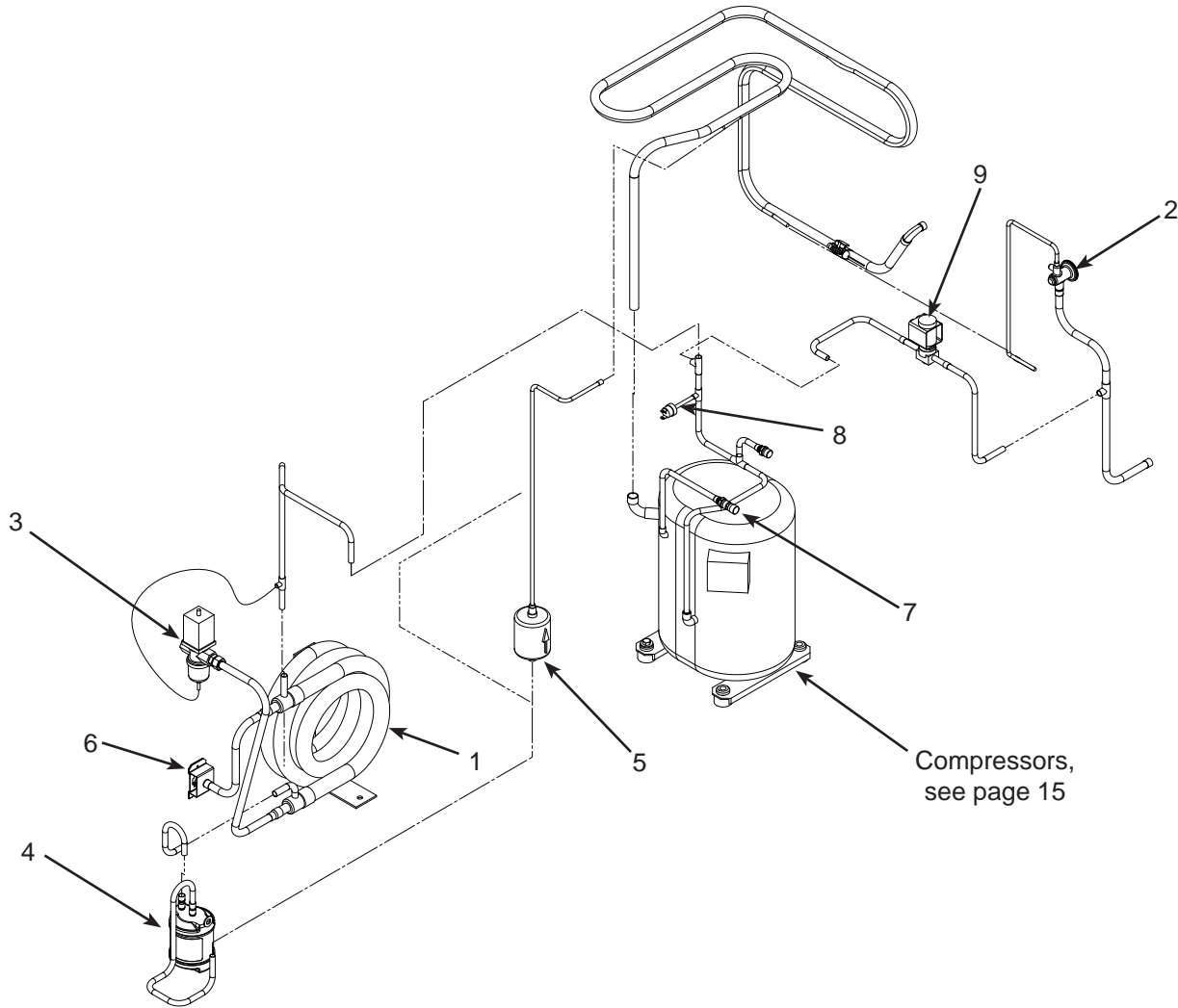

Item Number	Part Number	Description
1	18-8893-21	Condenser, WC, 1030
2	16-1142-01	TXV 1030
	19-0599-06	Insulation TXV
3	11-0608-21	Water regulating valve
4	16-0874-01	Receiver, 830, 1030
5	02-3319-02	Dryer, 1030
6	A31828-002	Condenser drain
7	16-1137-01	Valve body 3/8"
7a	16-1138-01	Valve body 1/4"
	16-1139-01	Core (for item #7)
	16-1140-01	Cap (for item #7)
8	11-0501-21	High pressure cut out
9	11-0493-01	Hot gas valve, 230 volt
	12-2719-22	230 volt coil
	12-2733-30	HGV rebuild kit

MC0330, MC0530, MC0630, MC0830, MC1030 Service Parts

Water or Remote Cooled Back Panel

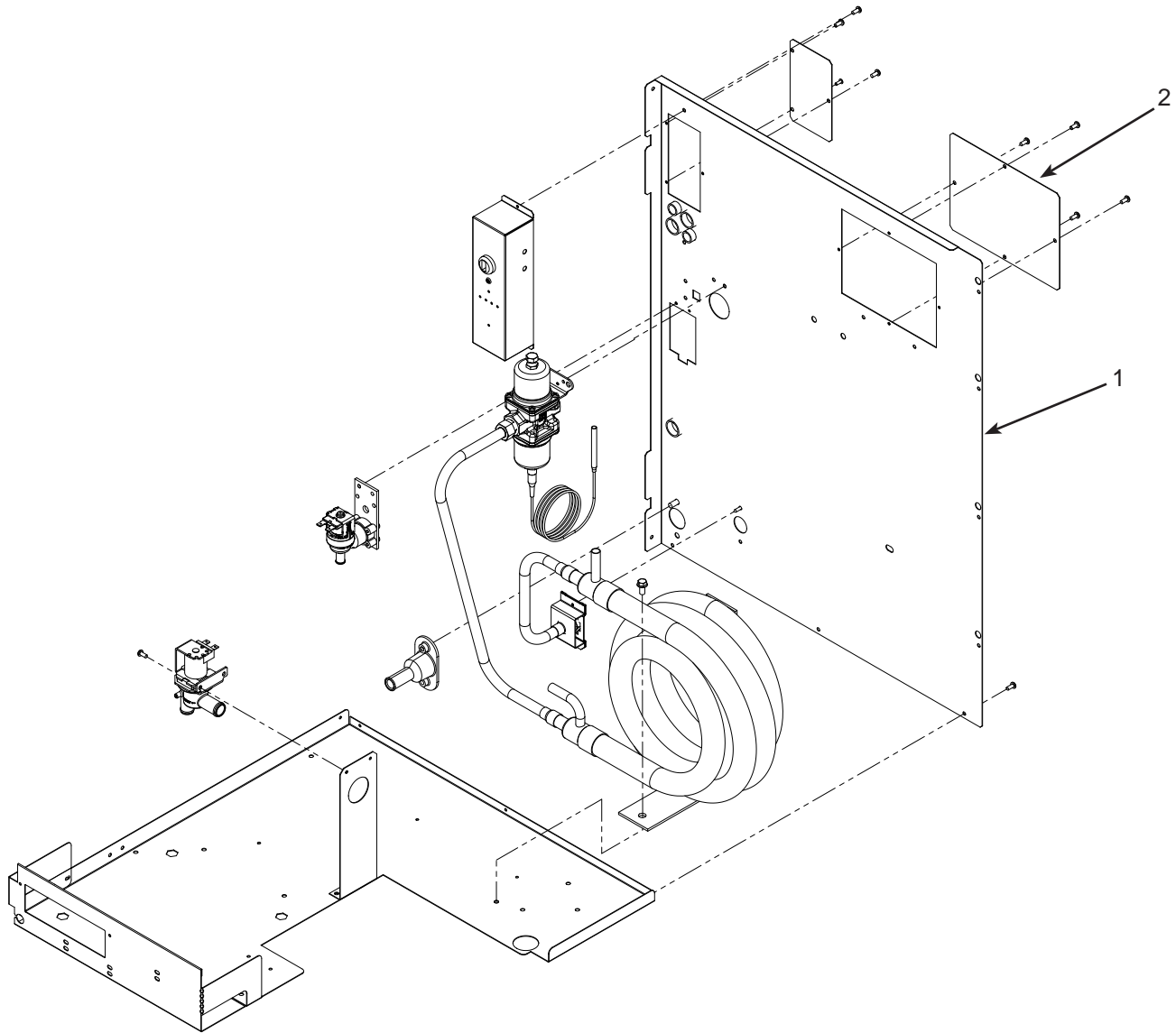

Item Number	Part Number	Description
1	A40515-001	Back pnl, WC, RC - 0330, 0530, 0630,
	A40654-001	Back pnl. cover WC
	A40522-001	Back pnl, WC, RC 0830
	A40522-001	Back pnl, WC, RC 1030
	A40416-001	Back pnl, RC - D series, 23"
2	A40654-001	Cover, water cooled models

MC0330, MC0530, MC0630, MC0830, MC1030 Service Parts

Electrical and Control Box

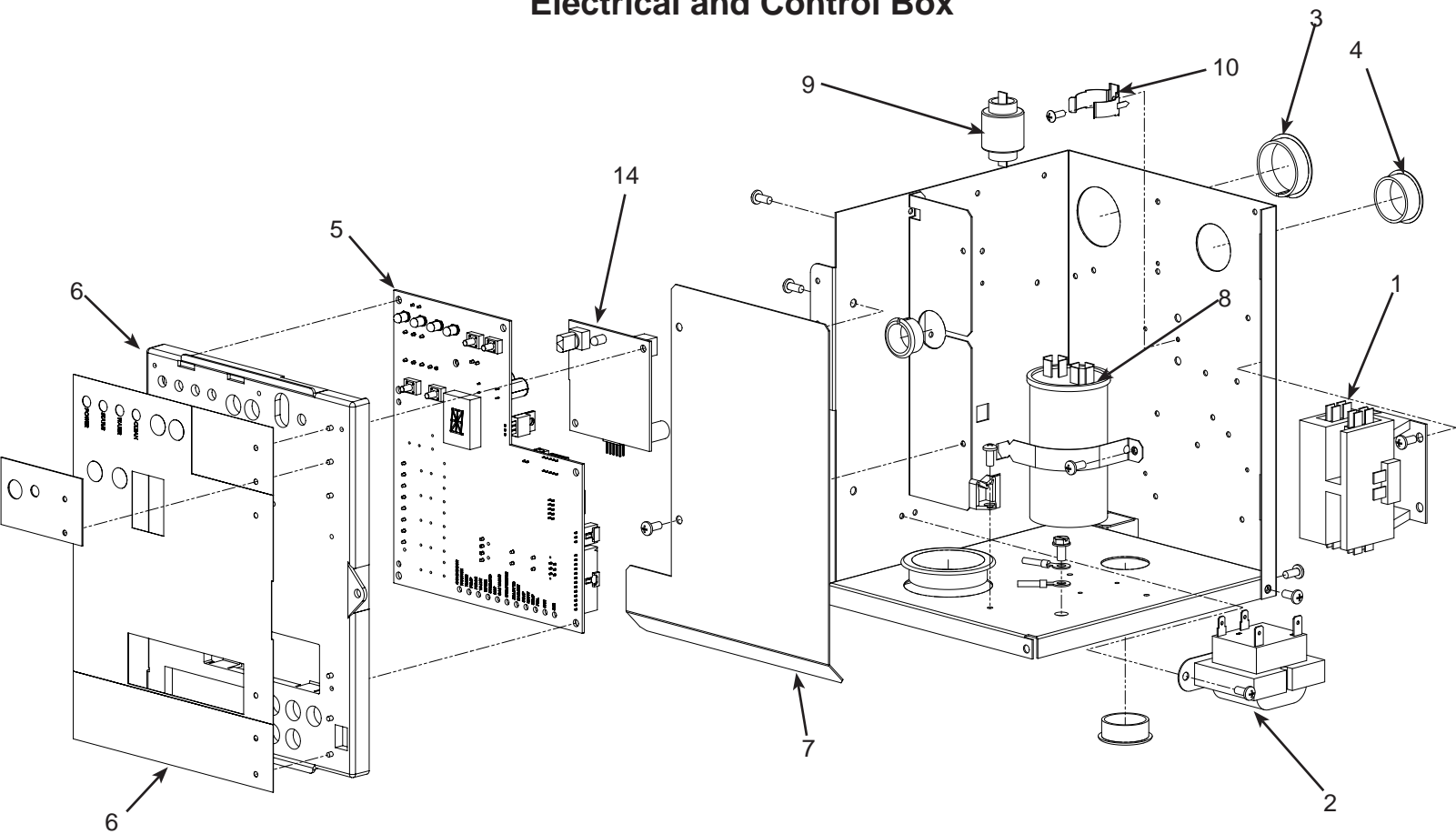

Item Number	Part Number	Description
1	12-2469-03	Contactors, 115 volt
	12-2469-02	Contactors, 230, single ph
	12-2533-02	Contactors, three phase
2	12-2924-01	Transformer, 115 volt
	12-2924-02	Transformer, 230 volt
3	12-1213-11	Snap bushing
4	12-1213-15	Snap bushing
5	11-0640-20	Controller for MC cubers
6	02-5168-01	Control box door
	02-5166-01	Overlay label
7	A39216-001	Barrier
8		see next page Run capacitor
9		see next page PTCR -
10	18-8835-02	Bracket
		Wiring Harnesses (not illustrated)
11	12-2931-01	Power harness, A & W
	12-2931-02	Power harness, Remote
		Power harness connects to J1 on controller
12	12-2932-01	Hi voltage harness, A & W
	12-2933-01	Hi voltage harness, Rem
		Hi voltage harness has the 8 pin connector
13	12-3185-01	WLS harness
14	KVS	Vari-smart ice level control
15	KSBU-N	

MC0330, MC0530, MC0630, MC0830, MC1030 Service Parts

Compressors

Model	Series	Electrical	Compressor	Overload	Run Capacitor	PTCR
MC0330-1		115/60/1	18-8948-21	18-8948-50*	18-1902-64*	18-8835-01*
MC0330-32		208-230/60/1	18-8948-23	18-8948-51*	18-1902-30*	18-8835-01*
MC0530-1		115/60/1	18-8948-21	18-8948-50*	18-1902-64*	18-8835-01*
MC0530-32		208-230/60/1	18-8948-23	18-8948-51*	18-1902-30*	18-8835-01*
MC0530-6		230/50	18-8948-22	18-8948-51*	18-1902-65*	18-8835-01*
MC0630-32		208-230/60/1	18-8955-22	internal	18-1902-67*	18-8835-01*
MC0630-6		230/50	18-8990-06	internal	18-1902-63*	18-8835-01*
MC0830-32		208-230/60/1	18-8813-23	internal	18-1902-69*	18-8835-01*
MC0830-3		208-230/60/3	18-8813-25	internal	-	-
MC0830-6		230/50	18-8813-27	internal	18-1902-69*	18-8835-01*
MC1030-32		208-230/60/1	18-8726-23	internal	18-1902-69*	18-8835-01*
MC1030-3		208-230/60/3	18-8726-25	internal	-	-
MC1030-6		230/50	18-8726-15		18-1902-69	18-8835-01

* Replacement compressors include selected components and a filter dryer. They may also include other components used only on other models. CS type compressors include fittings to adapt to prior tubing sizes.

MC0330, MC0530, MC0630, MC0830, MC1030 Service Parts

Compressor Mounting Hardware / Crankcase Heater

Model	Series	Bolt	Washer	Grommet	Sleeve
MC0330		03-1405-20	03-1407-07	18-4700-28	18-0108-41
MC 0330 or 0530		03-1405-20	03-1407-07	18-2200-28	18-2200-27
MC0630		03-1405-20	03-1407-07	18-2200-28	18-2200-27
MC0830 or 1030		03-1405-20	03-1407-07	18-2300-27	18-2300-26

Model		Crankcase heater
MC0530R		12-3043-01
MC0630R		12-3043-02
MC0830R or MC1030R		12-3043-03
MC1030R		12-1868-05 external

* Replacement compressors include selected components and a filter dryer. They may also include other components used only on other models. CS type compressors include fittings to adapt to prior tubing sizes.

MC0330, MC0530, MC0630, MC0830, MC1030 Service Parts

Remote Condenser, ERC111, ERC211 and ERC311

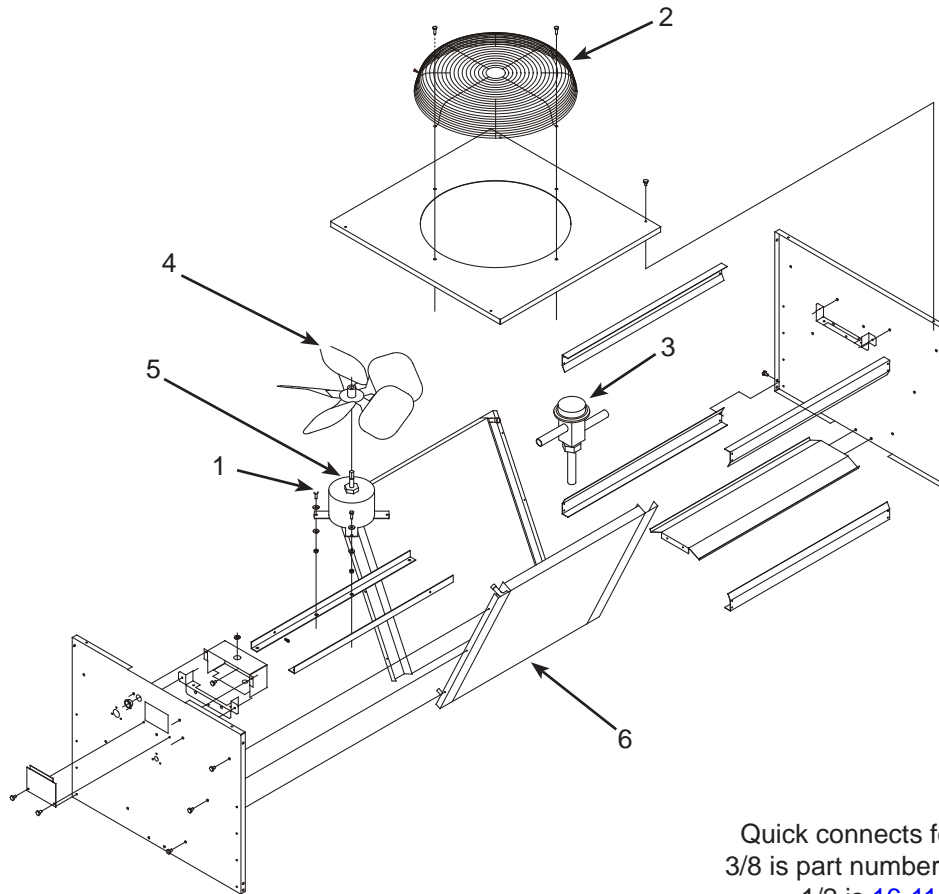

Quick connects for line sets:
 3/8 is part number [16-1100-08](#);
 1/2 is [16-1100-09](#).

Item Number	Part Number	Description
1	03-1405-08	Screw
2	02-3575-01	Fan guard
3	11-0422-22	Headmaster
4	18-8816-01	Fan blade
5	12-2651-01	Fan motor - 230 volt (ERC311)
	12-2651-02	Fan motor - 115 volt (ERC111 and ERC211)
6	18-8815-01	Coil, ERC111
	18-8827-01	Coil, ERC311

Not Shown:

A37169-001	Leg
A37170-001	Leg brace
03-1645-01	Screw for legs
16-0850-01	Quick connect, discharge
16-0850-03	Quick connect, liquid

MC0330, MC0530, MC0630, MC0830, MC1030 Service Parts

Wiring Diagram MC0330, MC0530 or MC0630

17-3736-01

(AIR COOLED ONLY)
 (WHEN 2ND FAN IS PRESENT)

USE COPPER CONDUCTORS ONLY

CAUTION: PTCR WILL BE HOT. COMPRESSOR MAY NOT START IF PTCR IS NOT ALLOWED TO COOL

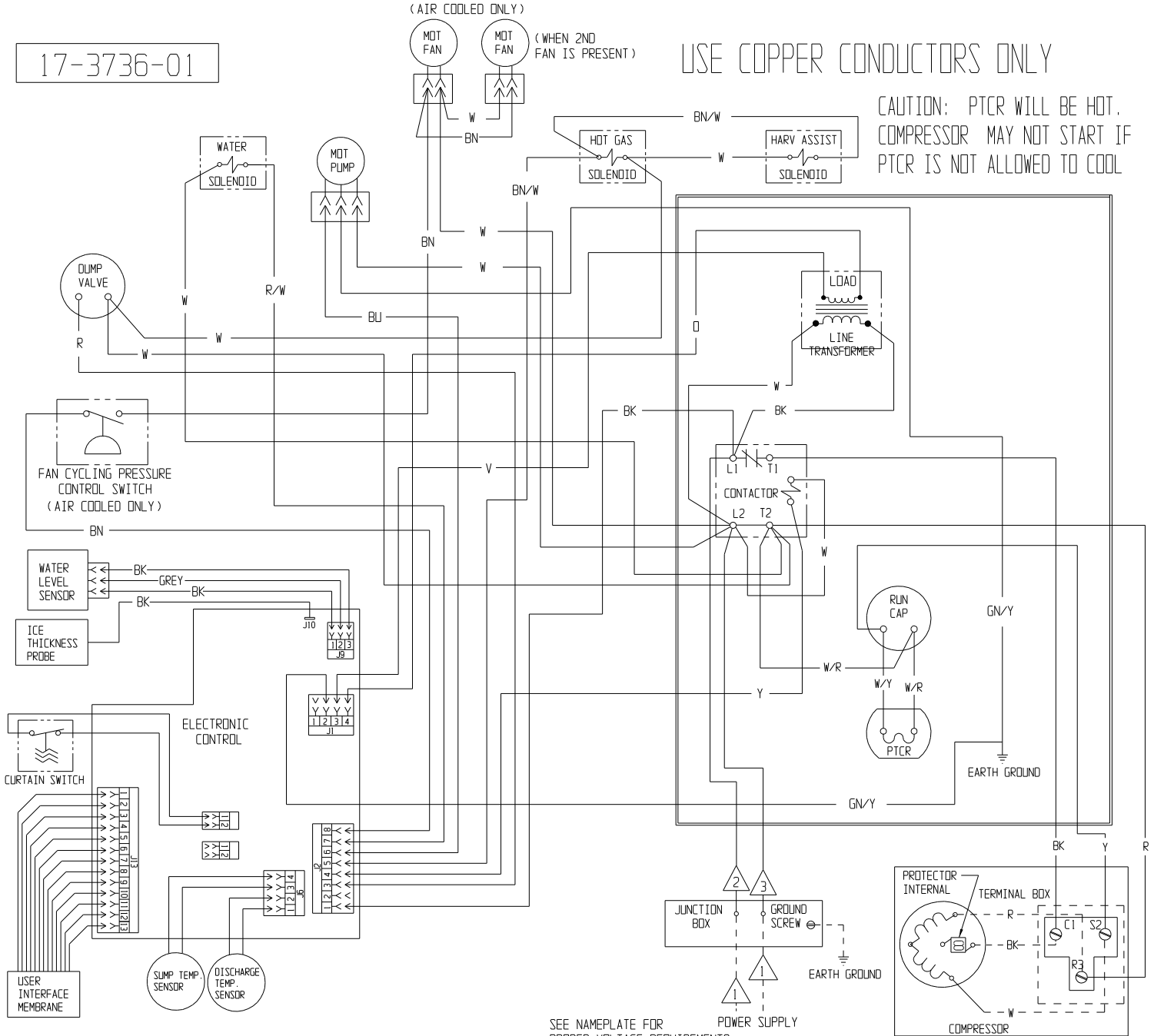

CAUTION: SEE NAMEPLATE FOR PROPER VOLTAGE REQUIREMENTS AND MAXIMUM FUSE SIZE. MORE THAN ONE DISCONNECT MEANS MAY BE REQUIRED TO DISCONNECT ALL POWER TO THIS UNIT.

- ⚠ WIRE COLOR FOR 115/60/1 UNITS: WHITE
- WIRE COLOR FOR 208-230/60/1 EXCEPT CR UNITS: BLACK W/WHITE STRIP
- WIRE COLOR FOR ONLY CR0630 UNITS: BROWN

- ⚠ DASHED LINES INDICATE FIELD WIRING WHICH MUST BE INSTALLED IN ACCORDANCE WITH THE NATIONAL ELECTRICAL CODE AND ALL STATE AND LOCAL CODES.
- ⚠ WIRE COLOR FOR 208-230/60/1 AND 115/60/1 UNITS: BLACK

MC0330, MC0530, MC0630, MC0830, MC1030 Service Parts

Schematic Diagram MC0330, MC0530 or MC0630

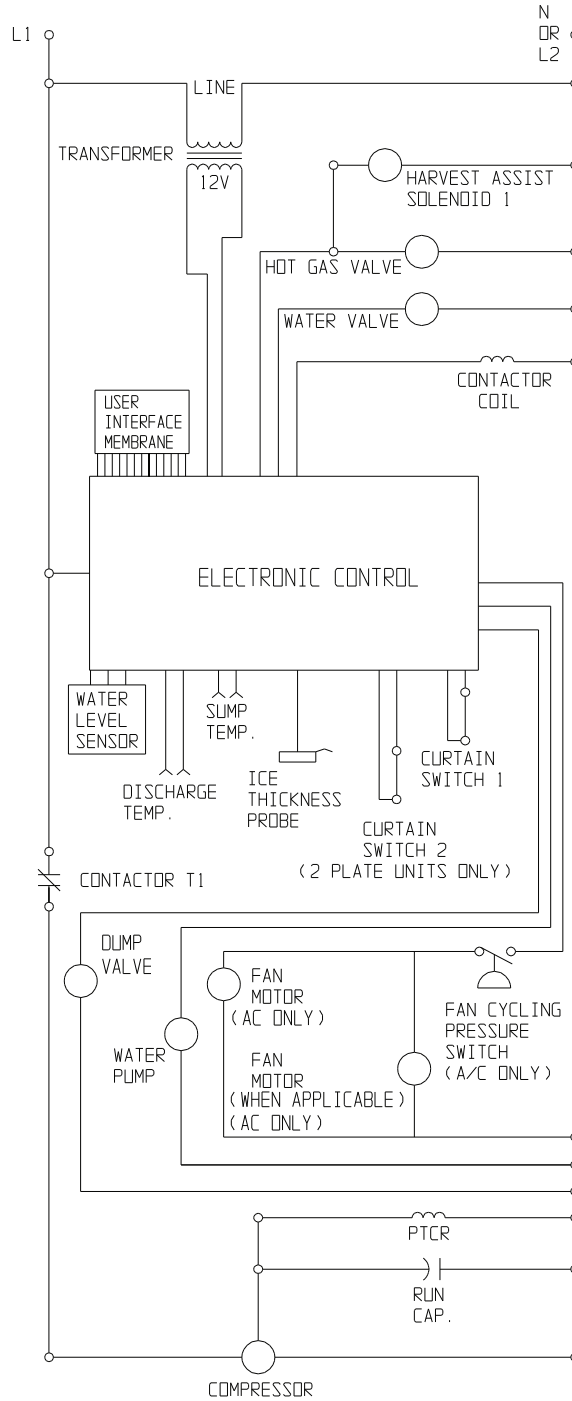

MC0330, MC0530, MC0630, MC0830, MC1030 Service Parts

Wiring Diagram MC0530R or MC0630R

USE COPPER CONDUCTORS ONLY

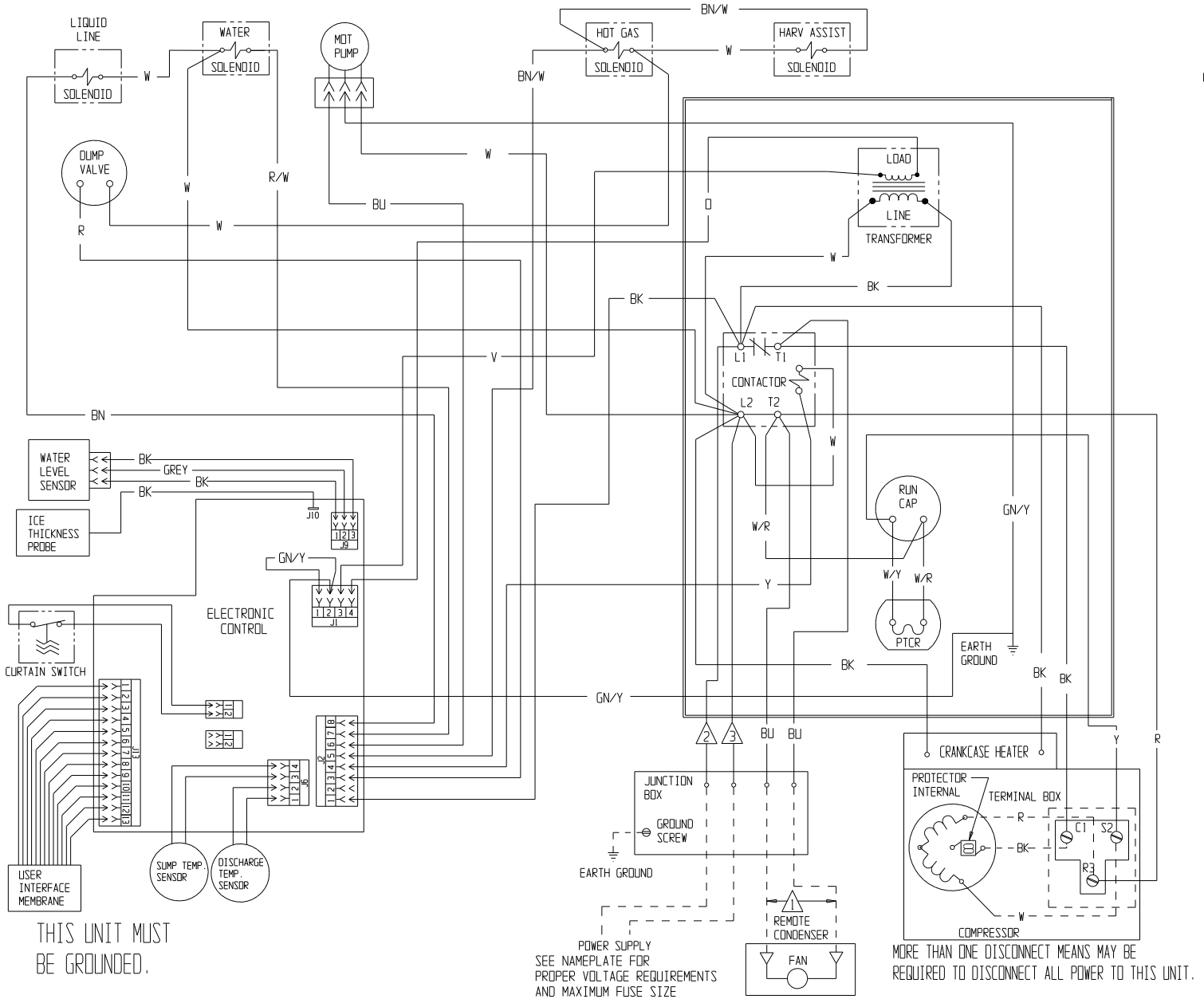

THIS UNIT MUST BE GROUNDED.

- ⚠ WIRE COLOR FOR 115/60/1 UNITS: WHITE
- WIRE COLOR FOR 208-230/60/1 EXCEPT CR UNITS: BLACK W/WHITE STRIP
- WIRE COLOR FOR ONLY CR0630 UNITS: BROWN

- ⚠ DASHED LINES INDICATE FIELD WIRING WHICH MUST BE INSTALLED IN ACCORDANCE WITH THE NATIONAL ELECTRICAL CODE AND ALL STATE AND LOCAL CODES.

- ⚠ WIRE COLOR FOR 208-230/60/1 AND 115/60/1 UNITS: BLACK

MC0330, MC0530, MC0630, MC0830, MC1030 Service Parts

Schematic Diagram MC0530R or MC0630R

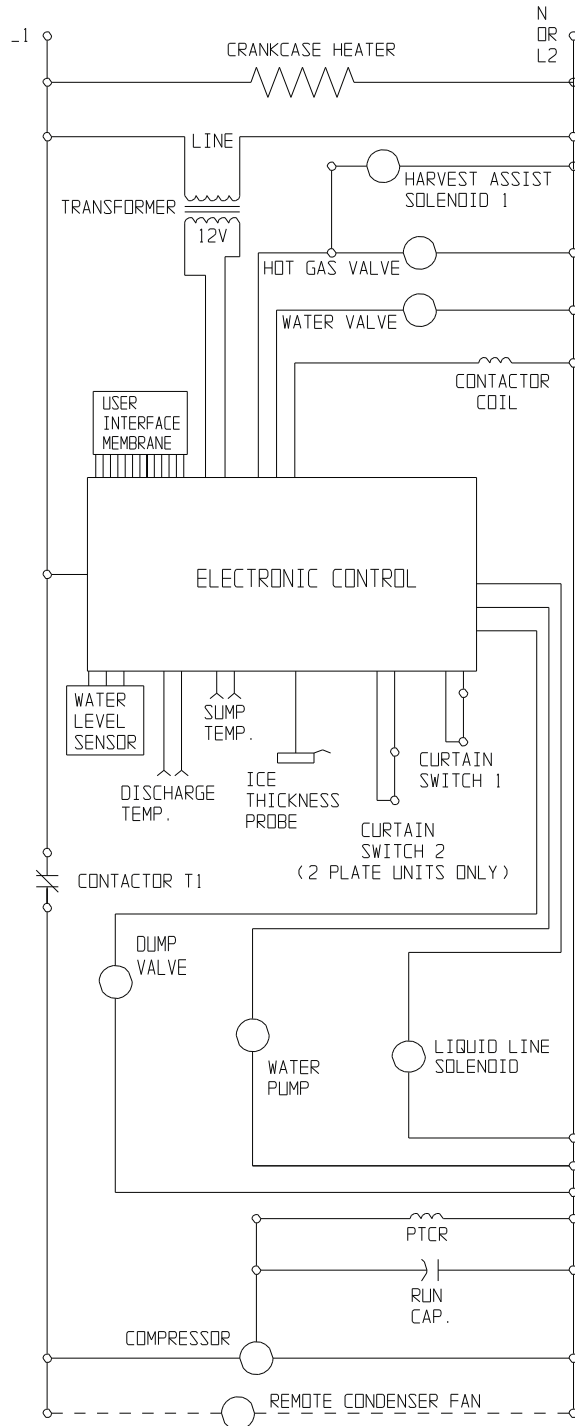

MC0330, MC0530, MC0630, MC0830, MC1030 Service Parts

Wiring Diagram MC0830 MC1030 Air or Water -32

17-3743-01

USE COPPER CONDUCTORS ONLY

CAUTION: PTCR WILL BE HOT. COMPRESSOR MAY NOT START IF PTCR IS NOT ALLOWED TO COOL

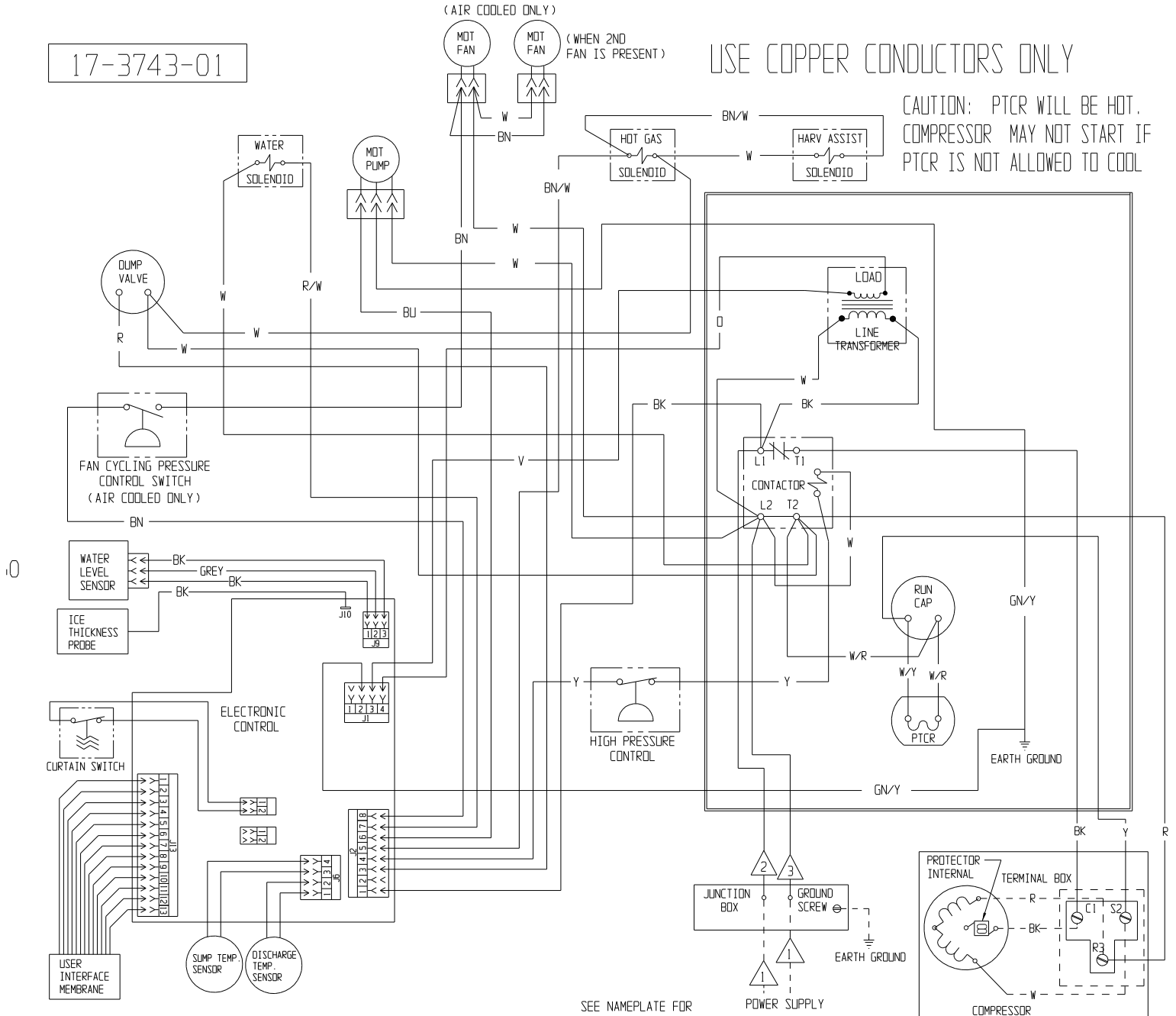

CAUTION: MORE THAN ONE DISCONNECT MEANS MAY BE REQUIRED TO DISCONNECT ALL POWER TO THIS UNIT.

THIS UNIT MUST BE GROUNDED.

- ⚠ WIRE COLOR FOR 115/60/1 UNITS: WHITE
- ⚠ WIRE COLOR FOR 208-230/60/1 EXCEPT CR UNITS: BLACK W/WHITE STRIP
- ⚠ WIRE COLOR FOR ONLY CR0322, CR0522, CR0630 AND CR1030 UNITS: BROWN

- ⚠ DASHED LINES INDICATE FIELD WIRING WHICH MUST BE INSTALLED IN ACCORDANCE WITH THE NATIONAL ELECTRICAL CODE AND ALL STATE AND LOCAL CODES.
- ⚠ WIRE COLOR FOR 208-230/60/1 AND 115/60/1 UNITS: BLACK

MC0330, MC0530, MC0630, MC0830, MC1030 Service Parts

Schematic Diagram MC0830 MC1030 Air or Water -32

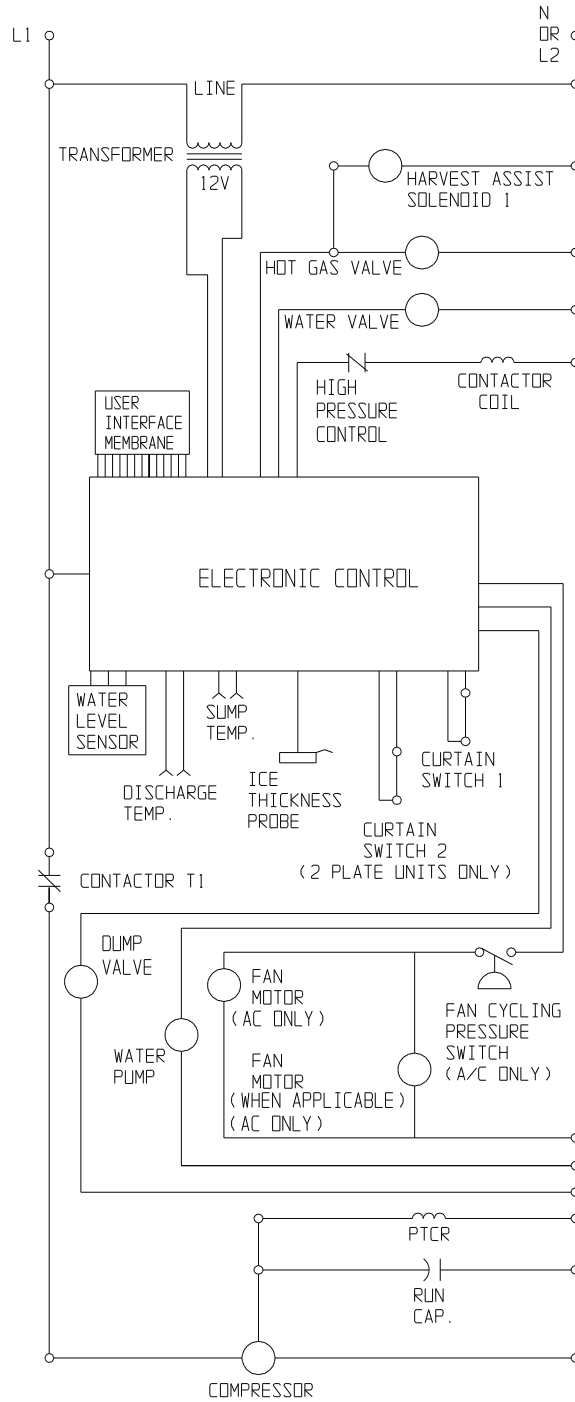

MC0330, MC0530, MC0630, MC0830, MC1030 Service Parts

Wiring Diagram MC0830, MC1030 Air or Water -3

3100

17-3746-01

(AIR COOLED ONLY)
 (WHEN 2ND FAN IS PRESENT)

USE COPPER CONDUCTORS ONLY

CAUTION: PTCR WILL BE HOT.
 COMPRESSOR MAY NOT START IF
 PTCR IS NOT ALLOWED TO COOL

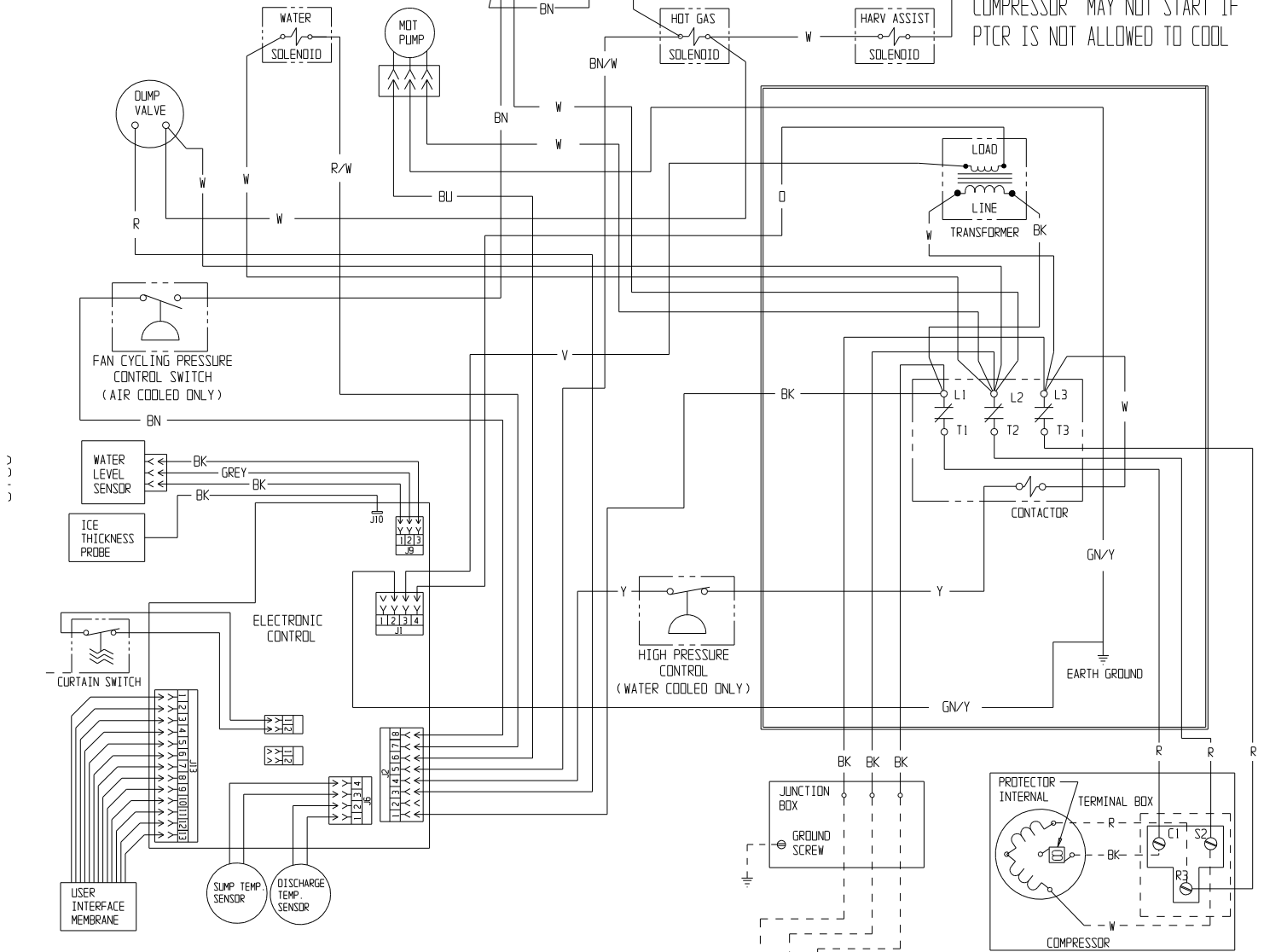

THIS UNIT MUST
 BE GROUNDED.

CAUTION:
 MORE THAN ONE DISCONNECT MEANS MAY BE
 REQUIRED TO DISCONNECT ALL POWER TO THIS UNIT.

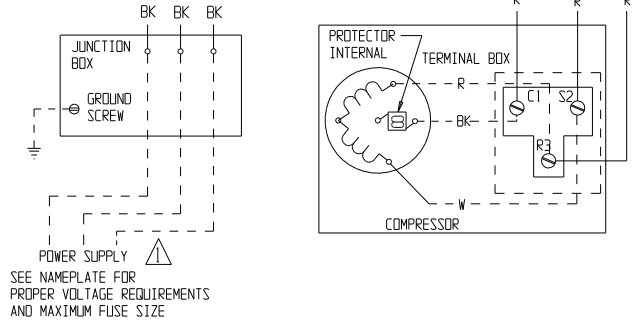

⚠ DASHED LINES INDICATE FIELD WIRING WHICH MUST BE
 INSTALLED IN ACCORDANCE WITH THE NATIONAL ELECTRICAL
 CODE AND ALL STATE AND LOCAL CODES.

MC0330, MC0530, MC0630, MC0830, MC1030 Service Parts

Wiring Diagram MC0830, MC1030 Air or Water -3

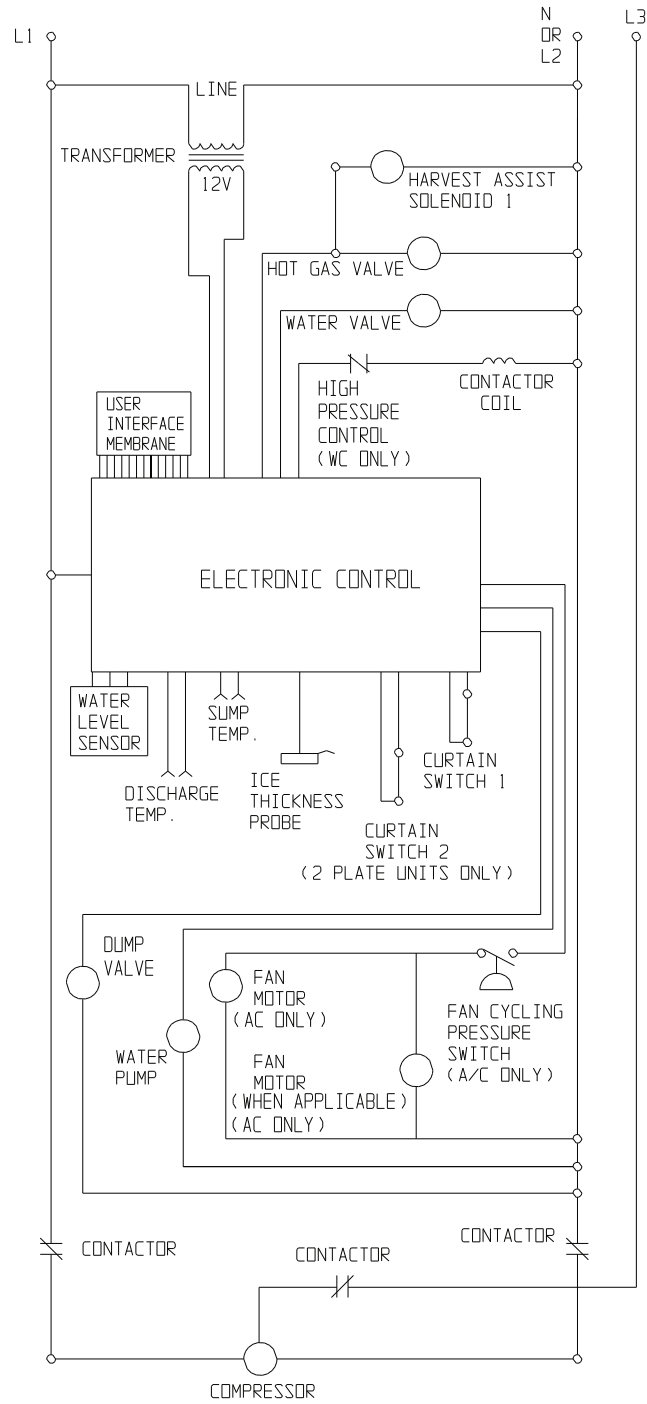

MC0330, MC0530, MC0630, MC0830, MC1030 Service Parts

Wiring Diagram MC0830, MC1030 Remote -3

17-3744-01

USE COPPER CONDUCTORS ONLY

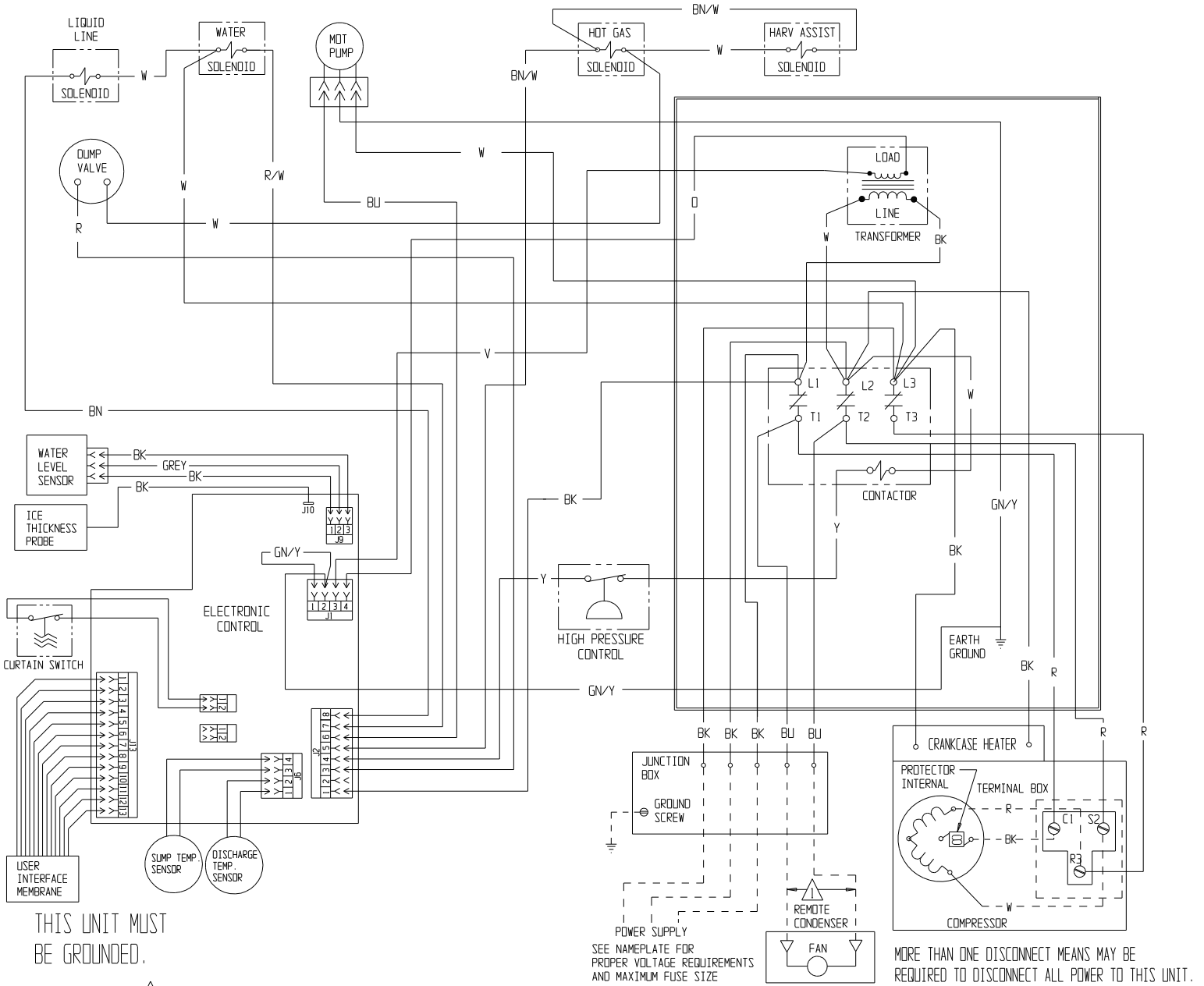

THIS UNIT MUST BE GROUNDED.

⚠ DASHED LINES INDICATE FIELD WIRING WHICH MUST BE INSTALLED IN ACCORDANCE WITH THE NATIONAL ELECTRICAL CODE AND ALL STATE AND LOCAL CODES.

MORE THAN ONE DISCONNECT MEANS MAY BE REQUIRED TO DISCONNECT ALL POWER TO THIS UNIT.

MC0330, MC0530, MC0630, MC0830, MC1030 Service Parts

Schematic Diagram MC0830, MC1030 Remote -3

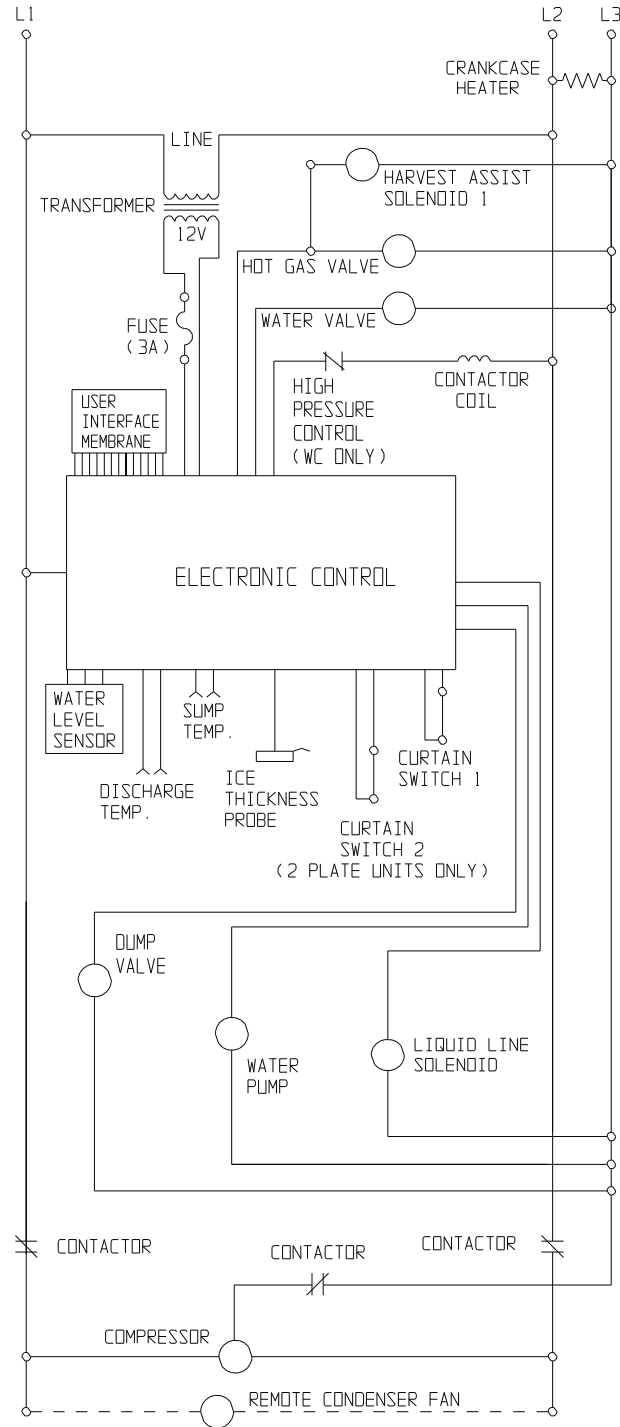

MC0330, MC0530, MC0630, MC0830, MC1030 Service Parts

Wiring Diagram MC0830, MC1030 Remote -32

17-3745-01

USE COPPER CONDUCTORS ONLY

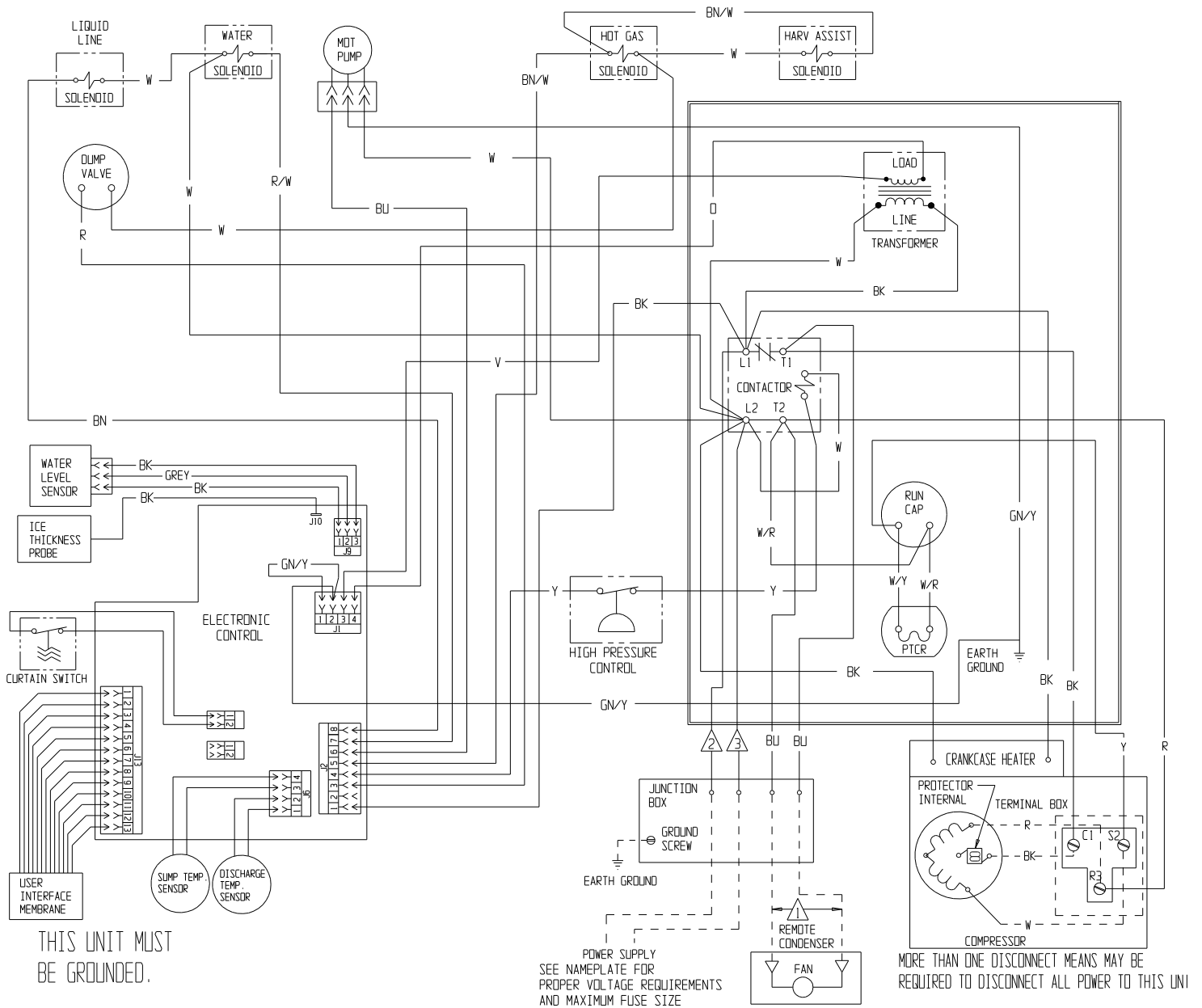

THIS UNIT MUST BE GROUNDED.

⚠ WIRE COLOR FOR 115/60/1 UNITS: WHITE
WIRE COLOR FOR 208-230/60/1 UNITS: BLACK W/WHITE STRIPE

⚠ DASHED LINES INDICATE FIELD WIRING WHICH MUST BE INSTALLED IN ACCORDANCE WITH THE NATIONAL ELECTRICAL CODE AND ALL STATE AND LOCAL CODES.

⚠ WIRE COLOR FOR 208-230/60/1 AND 115/60/1 UNITS: BLACK

MC0330, MC0530, MC0630, MC0830, MC1030 Service Parts

Schematic Diagram MC0830, MC1030 Remote -32

